



**Pennsylvania**  
**Department of**  
**Environmental Protection**

**EROSION AND SEDIMENT POLLUTION**  
**CONTROL PROGRAM MANUAL**

**FINAL**

**Technical Guidance Number**  
**386-2134-001**

**March 2012**

**BUREAU OF CLEAN WATER**

**DEPARTMENT OF ENVIRONMENTAL PROTECTION**  
**Bureau of Clean Water**

**DOCUMENT NUMBER:** 386-2134-001

**TITLE:** Erosion and Sediment Pollution Control Program Manual

**EFFECTIVE DATE:** March 31, 2012

**AUTHORITY:** Pennsylvania Clean Stream Law (35 P.S. §§ 691.1—691.1001) and regulations at 25 Pa. Code Chapter 102.

**POLICY:** It is the policy of the Department of Environmental Protection (DEP) to provide guidance and procedures for those engaged in earth disturbance activities on ways to minimize accelerated erosion and resulting sediment pollution to surface waters.

**PURPOSE:** The purpose of this guidance is to inform those engaged in earth disturbance activities and in the preparation of Erosion and Sediment Control (E&S) Plans how to comply with regulations found at 25 Pa. Code Chapter 102.

**APPLICABILITY:** This guidance applies to all those engaged in the preparation of E&S Plans for earth disturbance activities in the Commonwealth of Pennsylvania.

**DISCLAIMER:** The policies and procedures outlined in this guidance are intended to supplement existing requirements. Nothing in the policies or procedures shall affect regulatory requirements.

The policies and procedures herein are not an adjudication or a regulation. There is no intent by DEP to give the rules in these policies that weight or deference. This document establishes the framework within which DEP will exercise its administrative discretion in the future. DEP reserves the discretion to deviate from this policy statement if circumstances warrant.

**PAGE LENGTH:** 585 pages

**DEFINITIONS:** See 35 P.S. § 691.1 and 25 Pa. Code § 102.1.

## FOREWORD

The various Best Management Practices (BMPs) described herein are primarily used during earth disturbances associated with land development and construction activities. Other special BMPs for agricultural plowing or tilling activities which provide for the economic viability of farms, maintenance of the land, and protection of Pennsylvania waterways are described in the Natural Resources Conservation Services' ***Pennsylvania Soil and Water Conservation Technical Guide***. An overview of these agricultural BMPs is also provided in ***A Conservation Catalog: Practices for the Conservation of Pennsylvania's Natural Resources***. Persons conducting agricultural plowing or tilling activities are encouraged to review the practices described in the catalog and contact their local conservation district or Natural Resources Conservation Service office for more detailed planning information and assistance.

This manual lists various BMPs and design standards which are acceptable in Pennsylvania. BMPs, when designed according to these standards, and properly implemented and maintained, are expected to achieve the regulatory standard of minimizing the potential for accelerated erosion and sedimentation, and at the same time to protect, maintain, reclaim and restore water quality and existing and designated uses of surface waters.

This manual contains a selection of performance oriented BMPs that minimize accelerated soil erosion and sedimentation associated with temporary earth disturbance activities. It is a tool for developing erosion and sediment control plans that use basic principles of sound science and reasonable scientific certainty for minimizing accelerated erosion and sedimentation. Erosion and sediment control BMPs associated with earth disturbance activities have undergone extensive research and development to achieve the desired level of BMP effectiveness. Much of the design criteria and supporting calculations have been developed through various technical organizations, academia, and government agencies with expertise of the management practice functionality, standardized test methods and procedures, statistical analysis, and environmental, health and safety considerations. The BMP standards and specifications adopted by the Department are typically identified and used for the specific field applications as a performance-based effluent limitation for sediment and related pollutants. Many of the supporting calculations are assumed and have been incorporated into the standard details and specifications; however, some simple calculations for drainage area, slope steepness and length, or other site-specific feature may need to be identified to apply the practice for the earth disturbance activity. Generally, details and specifications identify the purpose of the BMP, conditions where the BMP applies, planning considerations, design criteria, construction specifications and maintenance procedures.

Alternate BMPs that are not listed in this manual but that provide the same (or greater) level of protection may also be used to attain the regulatory standard. It is incumbent on the person proposing the use of alternative BMPs to demonstrate their effectiveness with appropriate test results or other documentation.

BMPs that fail after installation shall be repaired to function properly or be replaced by alternative BMPs that will serve the intended purpose. For example, if a skimmer in a basin or trap does not function as intended, it may need to be replaced by a perforated riser that functions as intended. Likewise, if unforeseen conditions occur on a site, and the installed BMPs are obviously not effective, then alternate BMPs should be designed and installed. The need for redesign will be determined on a case-by-case basis.

Erosion is a natural process, which occurs with each runoff event. Human activities which remove protective vegetative cover alter topography and runoff patterns and typically increase the rate of erosion to many times that which occurs naturally. It is this accelerated erosion which is regulated by the Department's Chapter 102 regulations. Minimizing accelerated erosion and the resultant sedimentation is the focus of this manual.

## ACKNOWLEDGEMENTS

The following individuals and organizations participated in developing this manual. Participation does not infer concurrence or endorsement of the manual or its contents.

### **E&S Manual Oversight Committee:**

Barbara Beshore, PA DEP  
Robert Cadwallader, P.E., PA DEP  
Douglas W. Caylor, P.E., PA DEP  
James R. Coslo, Jr., Centre County Conservation District  
Chris Droste, Westmoreland Conservation District  
Brent Hilderbrand, Butler Conservation District  
Karl Kerchner, Lebanon County Conservation District  
Mark Lonergan, PA DEP  
Brian Mackowski, PA DEP  
Jeffrey McKenna, Montgomery County Conservation District  
Jeffrey Means, P.E., PA DEP  
Domenic Rocco, P.E., PA DEP  
Darl Rosenquest, P.E., P.G., PA DEP  
Bryon Ruhl, Berks County Conservation District  
Darrell Smeal, PA DEP  
Dennis Stum, P.E., PA DEP  
Christy Zulli, Schuylkill Conservation District

Special thanks to Stackhouse Bensinger, Inc. of Sinking Spring, PA for providing detail drawings for the Standard Construction Details contained in this manual and also to Britt Faucette of Filtrexx International for providing compost standards and details for compost filter socks. In addition, thanks to Assistant Professor William Elmendorf of The Pennsylvania State University for granting permission to include his publications regarding preservation and planting of trees on construction sites as appendices to this manual.

Finally, thank you to all who by their comments and suggestions helped make this manual better.

# TABLE OF CONTENTS

	Page
Foreword .....	ii
Acknowledgments .....	iii
Introduction .....	xv
Chapter 1 - Required E&S Plan Content .....	1
Chapter 2 - Best Management Practice (BMP) Sequencing .....	8
Chapter 3 - Site Access .....	13
Rock Construction Entrance .....	13
Rock Construction Entrance with Wash Rack .....	15
Rumble Pad .....	17
Wheel Wash .....	17
Temporary and Permanent Access Roads .....	18
Waterbar .....	21
Broad-based Dip .....	23
Open-top Culvert .....	26
Water Deflector .....	28
Roadside Ditch .....	30
Ditch Relief Culvert .....	31
Turnout .....	33
Compost Sock Sediment Trap .....	34
Temporary Stream and Wetland Crossings .....	36
Stream Crossing .....	36
Wetland Crossing .....	41
Earthwork within Stream Channels .....	42
Earthwork within Lakes and Ponds .....	49
Turbidity Barrier (Silt Curtain) .....	49
Dewatering Work Areas .....	53
Pumped Water Filter Bag .....	53
Sump Pit .....	55
Site Housekeeping and Materials Management .....	57
Waste Management .....	57
Concrete Washout .....	57
Chapter 4 - Sediment Barriers and Filters .....	61
Compost Filter Sock .....	62
Compost Filter Berm .....	67
Weighted Sediment Filter Tube .....	69
Rock Filter Outlet .....	73
Silt Fence (Filter Fabric Fence) .....	75
Super Silt Fence (Super Filter Fabric Fence) .....	82
Sediment Filter Log (Fiber Log) .....	85
Wood Chip Filter Berm .....	87
Straw Bale Barrier .....	89
Rock Filter .....	92
Vegetative Filter Strip .....	94
Storm Inlet Protection .....	96
Inlet Filter Bag .....	97
Stone Inlet Protection .....	100
Chapter 5 - Runoff Calculations .....	108
The Rational Equation .....	110
Runoff Coefficient (C) .....	110
Rainfall Intensity (I) .....	112
Drainage Area (A) .....	123
Chapter 6 - Runoff Conveyance BMPs .....	127
Channels .....	127

	<b>Page</b>
Manning's Equation.....	127
Berm .....	150
Top-of-Slope Berm.....	150
Temporary Slope Pipe .....	153
Bench .....	157
Chapter 7 - Sediment Basins .....	159
Design Criteria .....	159
Storage Volume Criteria.....	164
Design Procedure .....	164
Skimmer Dewatering.....	166
Perforated Riser Dewatering .....	174
Freeboard .....	192
Emergency Spillway.....	192
Flow Length to Width Ratio .....	199
Outlet Barrels.....	202
Anti-seep Collar .....	203
Filter Diaphragm .....	209
Sediment Storage Zone Dewatering .....	211
Chapter 8 - Sediment Traps.....	212
Design Criteria .....	212
Embankment Sediment Trap.....	214
Barrel/Riser Sediment Trap.....	217
Chapter 9 - Outlet Protection .....	229
Riprap Apron.....	232
Flow Transition Mat.....	242
Stilling Basin (Plunge Pool) .....	245
Stilling Well .....	248
Energy Dissipater.....	251
Drop Structure.....	252
Earthen Level Spreader .....	253
Structural Level Spreader .....	255
Chapter 10 - Low Hazard Individual Lot E&S Plans .....	256
Chapter 11 - Stabilization Methods and Standards .....	260
Surface Roughening .....	260
Stair Step Grading.....	260
Grooving Slopes.....	261
Tracking Slopes.....	262
Vegetative Stabilization.....	262
Topsoil Application .....	263
Seeding.....	263
Mulching.....	270
Composting.....	271
Erosion Control Blankets.....	273
Hydraulically Applied Blankets.....	275
Soil Binders.....	276
Sodding.....	277
Cellular Confinement Systems .....	280
Chapter 12 - New Products and Procedures.....	282
Chapter 13 - Utility Line Projects.....	283
Roadway Crossings .....	284
Stream Crossings .....	284
Wetland Crossings.....	290

	<b>Page</b>
Waterbars .....	292
Chapter 14 - Timber Harvesting .....	294
Haul Roads .....	294
Skid Roads and Skid Trails .....	297
Log Landings .....	298
Winter Harvests .....	300
Retirement of Haul Roads, Skid Roads, Skid Trails, and Landings .....	302
Chapter 15 - Streambank Stabilization.....	303
Vegetation.....	303
Riprap .....	304
Gabions .....	307
Grid Pavers.....	310
Cellular Confinement Systems .....	312
Miscellaneous Hard Armor Techniques.....	313
Fluvial Geomorphology (FGM) Techniques.....	313
Bioengineering .....	314
Live Stakes.....	314
Live Fascines .....	316
Branchpacking.....	319
Fabric Encapsulated Soil.....	321
Fiber Rolls .....	323
Chapter 16 - Grading Standards .....	325
Chapter 17 - Areas of Special Concern.....	327
Sinkhole Repair.....	327
Erosion and Sediment Pollution Control Practices for Contaminated Sites.....	332
NPDES Permits Involving Site Remediation and Redevelopment.....	340
Special Protection Watersheds .....	343
Policy .....	343
Antidegradation .....	343
Nondischarge Alternatives .....	344
Antidegradation Best Available Combination of Technologies (ABACT).....	344
ABACT BMPs for E&S Plans .....	345
Slope Failures.....	347
Geothermal Well Drilling .....	351
Appendix A - Checklists.....	354
Complete Plan Checklist .....	355
Standard E&S Control Plan Technical Review Checklist.....	357
Expanded E&S Control Plan Technical Review Checklist .....	360
Appendix B - Standard E&S Worksheets .....	371
Appendix C - Standard E&S Plan Notes .....	394
Appendix D - Standards for Maps and Drawings.....	397
Appendix E - Soil Use Limitations .....	400
Appendix F - Energy Dissipaters.....	410
Roughness Element Dissipater .....	411
Impact Dissipater .....	426
Appendix G - Technical Paper: "Level Spreaders and Off-site Discharges of Stormwater to Non- surface Waters" .....	430
Appendix H - Dust Control .....	451
Appendix I - Publication: "A Guide to Preserving Trees in Development Projects" by William Elmendorf of The Pennsylvania State University (1999) .....	454
Appendix J - Publication: "Understanding Tree Planting in Construction-damaged Soils" by William Elmendorf of The Pennsylvania State University (2008).....	483

Appendix K - Fact Sheet - E & S BMPs for Water Well Drilling and Aquifer Testing.....	496
Appendix L - Glossary.....	498

### LIST OF TABLES

Table Number	Name	Page
3.1	Maximum Waterbar Spacing.....	22
3.2	Maximum Spacing of Broad-based Dips, Open-top Culverts and Deflectors.....	23
3.3	Sizing and Spacing of Ditch Relief Culverts for Temporary Access Roads.....	31
3.4	Recommended Maximum Spacing of Ditch Relief Culverts (18" dia CMP) for Permanent Access Roads .....	32
3.5	Minimum Distance Between Culvert Pipes.....	37
4.1	Compost Sock Fabric Minimum Specifications.....	63
4.2	Compost Standards.....	64
4.3	Fabric Properties for Silt Fence.....	75
4.4	Maximum Slope Length for Silt Fence .....	76
4.5	Maximum Slope Length for Straw Bale Barriers and Wood Chip Filter Berms.....	89
4.6	Minimum Filter Strip Width for Sediment Removal .....	95
5.1	Pennsylvania Rainfall by County.....	109
5.2	Runoff Coefficients for the Rational Equation .....	111
5.3	Roughness Coefficient for Sheet Flow $T_c$ Computations .....	112
5.4	Appropriate Rainfall Regional Map for Various Times of Concentration and Frequencies.....	114
5.5	5-Minute through 24-Hour Rainfall Depths for Region 1 .....	118
5.6	5-Minute through 24-Hour Rainfall Depths for Region 2.....	119
5.7	5-Minute through 24-Hour Rainfall Depths for Region 3.....	120
5.8	5-Minute through 24-Hour Rainfall Depths for Region 4.....	121
5.9	5-Minute through 24-Hour Rainfall Depths for Region 5.....	122
6.1	Geometric Elements of Channel Sections.....	128
6.2	Maximum Permissible Shear Stresses for Various Channel Liners.....	130
6.3	Manning's "n" for Trapezoidal Channels with Vegetative Stabilization (Retardance C) .....	131
6.4	Maximum Permissible Velocities (ft/sec) for Channels Lined with Vegetation .....	132
6.5	Manning's Roughness Coefficient ("n") for Commonly Used Temporary Channel Linings .....	133
6.6	Riprap Gradation, Filter Blanket Requirements, Maximum Velocities.....	135
6.7	Comparison of Various Gradations of Coarse Aggregates.....	135
6.8	Riprap Size Adjustment Factor for Various Rock Types.....	136
6.9	Recommended n Values to be Used with Manning's Equation When Doing Stability Analyses of Receiving Streams .....	137
6.10	Maximum Permissible Velocities and Shear Stresses for Reno Mattresses and Gabions .....	139
6.11	Minimum Dimensions for Temporary Slope Pipes .....	154
6.12	Bench Spacing.....	157
7.1	$K_p$ Values for Common Sizes of Pipe .....	176
7.2	Pipe Flow Capacity - $n = 0.015$ .....	178
7.3	Pipe Flow Capacity - $n = 0.025$ .....	179
7.4	Concrete Base Requirements for Various Sizes of Temporary Riser Pipes .....	187
7.5	Grass-lined Emergency Spillway Capacity in CFS (Side Slopes 1H:1V) .....	196
7.6	Grass-lined Emergency Spillway Capacity in CFS (Side Slopes 2H:1V) .....	197
7.7	Grass-lined Emergency Spillway Capacity in CFS (Side Slopes 3H:1V) .....	197
7.8	Grass-lined Emergency Spillway Capacity in CFS (Side Slopes 4H:1V) .....	198
8.1	Recommended Minimum Pipe Sizes for Barrel/Riser Sediment Traps.....	217
11.1	Cubic Yards of Topsoil Required for Application to Various Depths .....	263
11.2	Soil Amendment Application Rate Equivalents.....	266
11.3	Plant Tolerances of Soil Limitation Factors .....	267



<b>Table Number</b>	<b>Name</b>	<b>Page</b>
11.4	Recommended Seed Mixtures .....	268
11.5	Recommended Seed Mixtures for Stabilizing Disturbed Areas .....	269
11.6	Mulch Application Rates .....	271
11.7	Typical Polymer Stabilized Fiber Matrix Application Rates .....	276
13.1	Maximum Spacing and Materials for Trench Plugs .....	291
13.2	Maximum Spacing for Permanent Waterbars on a Utility Line Right-of-way .....	293
14.1	Minimum Vegetative Filter Strip Widths for Timber Harvesting.....	298
15.1	Live Fascine Spacing.....	317
16.1	Recommended Minimum Setbacks for Fill Placement in the Vicinity of Regulated Waters, Highways, Railroads, and Other Public Transportation Facilities .....	326
17.1	Processes Leading to Landslides.....	349
E.1	Limitations of Pennsylvania Soils Pertaining to Earthmoving Projects.....	401
F.1	Impact Dissipater Dimensions (ft-inches) .....	427
G.1	Allowable Velocities for Downslope Covers for Channel Flows .....	441
G.2	Maximum Velocities of Flow Across a Level Spreader .....	443
G.3	Level Spreader Lengths for Various Downslope Covers and Discharges.....	444
G.4	Reduced Level Spreader Lengths for Wooded Riparian Buffers .....	444
H.1	Application Rates for Dust Suppressants .....	452
H.2	Adhesives Used for Dust Control .....	453

## LIST OF FIGURES

Figure Number	Name	Page
I.1	Raindrop Impact .....	xv
I.2	Types of Erosion.....	xvi
3.1	Typical Roadside Ditch Section .....	30
3.2	Access Road Layout.....	30
3.3	Typical Turnout.....	33
3.4	Temporary Bridge Stream Crossing.....	38
3.5	Typical Tire Mat Wetland Crossing .....	41
3.6	Typical Expanded Metal Grating Wetland Crossing .....	41
3.7	Typical Wood Mat For Wetland Crossing.....	42
3.8	Typical Causeway.....	43
3.9	Bypass Channel with Non-erosive Lining.....	44
3.10	Rigid or Flexible Pipe Flume Through a Work Area .....	45
3.11	Temporary Cofferdam and Pump Bypass Around In-channel Work Areas.....	46
3.12	In-stream Cofferdam Diversion .....	47
3.13	Jersey Barrier Cofferdam-end View .....	48
3.14	Turbidity Barrier Installation - No Current and Sheltered from Wind and Waves.....	50
3.15	Turbidity Barrier Installation - Small to Moderate Current ( $\leq 3.5$ FPS) and Some Wind and Wave Action .....	51
3.16	Turbidity Barrier Installation - Considerable Current (3.5 -5 FPS) and Potential Tidal, Wind and Wave Action .....	51
3.17	Turbidity Barrier Installation - Tidal Condition.....	52
3.18	Typical Compost Sock Washout Installation .....	58
4.1	Sediment Barrier Alignment .....	61
4.2	Maximum Permissible Slope Length Above Compost Filter Socks.....	66
4.3	Maximum Permissible Slope Length Above Silt Fence and Straw Bale Barriers.....	78
4.4	Straw Bale Barrier Installation.....	91
4.5	Vegetative Filter Strip.....	95
5.1	Nomograph to Determine Shallow Concentrated Flow Velocity .....	113
5.2	Rainfall Region Map A .....	115
5.3	Rainfall Region Map B .....	115
5.4	Rainfall Region Map C .....	116
5.5	Rainfall Region Map D .....	116
5.6	Rainfall Region Map E .....	117
5.7	Rainfall Region Map F .....	117
5.8	Rainfall Intensity for 1-year through 100-year Storms for Region 1 .....	118
5.9	Rainfall Intensity for 1-year through 100-year Storms for Region 2 .....	119
5.10	Rainfall Intensity for 1-year through 100-year Storms for Region 3 .....	120
5.11	Rainfall Intensity for 1-year through 100-year Storms for Region 4 .....	121
5.12	Rainfall Intensity for 1-year through 100-year Storms for Region 5 .....	122
6.1	Maximum Permissible Flow Depth for Riprap Channels.....	134
6.2	"n" Values for Riprap Channels.....	138
6.3	Plan Map of Sample Channel .....	140
6.4	Void Space in Riprap Channel Bottom.....	141
6.5	Maintaining Top-of-slope Berms and Temporary Slope Pipes.....	152
7.1	Sediment Basin.....	163
7.2	Skimmer Orifice Design Chart.....	173
7.3	Riser Inflow Curves.....	177
7.4	Typical Sediment Forebay .....	200
7.5	Use of Baffles in Sediment Basins .....	202
7.6	Anti-seep Collar Design .....	203

Figure Number	Name	Page
7.7	Graphical Determination of Length of Pipe in the Saturated Zone ( $L_s$ ) .....	206
7.8	Typical Filter Diaphragm Installation .....	209
9.1	Velocity Adjustment Nomograph for Less Than Full Pipe Flow .....	231
9.2	Proper Outfall Orientation to Receiving Stream.....	232
9.3	Riprap Apron Design, Minimum Tailwater Condition .....	239
9.4	Riprap Apron Design, Maximum Tailwater Condition .....	240
9.5	Typical Transition Mat Installation .....	243
9.6	Minimum Coverage Length vs. Exit Velocity for Flow Transition Mat .....	244
9.7	d50 Stone Size for Stilling Basins .....	247
9.8	Stilling Well Height.....	248
9.9	Stilling Well Diameter.....	249
9.10	Depth of Well Below Invert.....	250
9.11	Typical Drop Structure .....	252
11.1	Stair Step Grading of Cut Slopes .....	261
11.2	Grooved Slope Details.....	261
11.3	Tracking a Fill Slope .....	262
11.4	Straw Mulch Applied at 3 Tons/Acre .....	270
11.5	Sodding .....	279
11.6	Typical Cellular Confinement System Installation.....	281
13.1	Waterbar Installation on a Utility Line Right-of-way .....	293
14.1	Typical Timber Harvest Haul Road Layout.....	296
14.2	Typical Timber Harvest Site Plan.....	299
14.3	Alternative Timber Harvest Site Plan .....	300
14.4	Typical Timber Harvest Plan Mapping Symbols.....	301
15.1	Riprap Streambank Protection with Optional Live Stakes .....	305
15.2	Extension of Primary Rock Riprap Protection Area .....	306
15.3	Gabion Streambank Protection .....	308
15.4	Reno Mattress Streambank Protection .....	309
15.5	Grid Pavers.....	311
15.6	Live Stakes.....	315
15.7	Live Fascines.....	318
15.8	Branchpacking.....	320
15.9	Fabric Encapsulated Soil with Branchpacking.....	322
15.10	Fiber Rolls .....	324
17.1	Sinkhole Repair with a Bentonite Cap.....	328
17.2	Sinkhole Repair with a Pervious Cover .....	329
17.3	Sinkhole Repair with an Impervious Cover.....	330
17.4	Sinkhole Repair with Soil Cover.....	331
F.1	Typical Roughness Element Dissipater.....	411
F.2	Forces Acting on a Roughness Element.....	412
F.3	Critical Dimensions Used in Designing Roughness Element Dissipaters .....	412
F.4	Dimensionless Rating Curves for Outlets of Rectangular Culverts on Horizontal and Mild Slopes.....	417
F.5	Dimensionless Rating Curves for Outlets of Circular Culverts on Horizontal and Mild Slopes.....	418
F.6	Flow for Circular Pipe Flowing Full.....	419
F.7	Design Values for Roughness Element Dissipaters .....	420
F.8	Average Velocity in Abrupt Expansion below Rectangular Outlet.....	421
F.9	Average Velocity in Abrupt Expansion below Circular Outlet.....	422
F.10	Average Depth for Abrupt Expansion below Rectangular Outlet .....	423
F.11	Average Depth for Abrupt Expansion below Circular Outlet .....	424
F.12	Riprap Size for Use Downstream of Energy Dissipaters .....	425
F.13	Design Curve for Impact Dissipaters.....	428
F.14	Impact Dissipater Dimensions.....	429

<b>Figure Number</b>	<b>Name</b>	<b>Page</b>
G.1	Convex Contours and Slopes are Less Susceptible to Reconcentrating Flows .....	433
G.2	Turf Reinforcement Mat (TRM) for Level Spreader with Vegetated Lip .....	435
G.3	Typical Orientation of Level Spreader with Surface Discharge .....	435
G.4	Variation of Plunge Pool Dimensions .....	436
G.5	Typical Orientation of Level Spreader with Subsurface Discharge .....	437
G.6	View of Level Spreader Face Looking Downslope .....	438
G.7	Concentration of Flow Downslope of Level Spreader .....	441
G.8	Weir Equation Inputs.....	443
G.9	Outfall Layout .....	446
G.10	Rill/Gully Repair .....	447
G.11	Stream Bank/Gully Repair .....	447
G.12	Common Level Spreader Failures.....	448

## STANDARD CONSTRUCTION DETAILS

Number	Name	Page
3-1	Rock Construction Entrance .....	14
3-2	Rock Construction Entrance with Wash Rack .....	16
3-3	Crowned Roadway .....	19
3-4	Insloped Roadway .....	20
3-5	Waterbar.....	22
3-6	Broad-based Dip for Low Gradient ( $\leq 5\%$ ) Roadways.....	24
3-7	Broad-based Dip for High Gradient (5%-10%) Roadways.....	25
3-8	Open-top Culvert .....	27
3-9	Water Deflector.....	29
3-10	Ditch Relief Culvert.....	32
3-11	Compost Filter Sock Trap .....	35
3-12	Temporary Stream Crossing - Plan View.....	38
3-13	Temporary Stream Crossing.....	39
3-14	Temporary Stream Crossing - Multiple Pipes.....	40
3-15	Sandbag Diversion Dam or Cofferdam .....	48
3-16	Pumped Water Filter Bag.....	54
3-17	Sump Pit.....	56
4-1	Compost Filter Sock.....	65
4-2	Compost Filter Berm.....	68
4-3	Weighted Sediment Filter Tube Installation.....	70
4-4	Weighted Sediment Filter Tube Installation in a Concentrated Flow Area .....	71
4-5	Weighted Sediment Filter Tube Installation Across a Wide Flow Path .....	72
4-6	Rock Filter Outlet.....	74
4-7	Standard Silt Fence (18" High).....	79
4-8	Reinforced Silt Fence (30" High).....	81
4-9	Silt Fence Reinforced by Staked Straw Bales .....	81
4-10	Super Silt Fence .....	84
4-11	Sediment Filter Log (Fiber Log) .....	86
4-12	Wood Chip Filter Berm.....	88
4-13	Straw Bale Barrier.....	90
4-14	Rock Filter .....	93
4-15	Filter Bag Inlet Protection - Type C Inlet.....	98
4-16	Filter Bag Inlet Protection - Type M Inlet .....	99
4-17	Stone and Concrete Block Inlet Protection - Type C Inlet .....	100
4-18	Stone and Concrete Block Inlet Protection - Type M Inlet .....	101
4-19	Stone Inlet Protection and Berm - Type C Inlet .....	102
4-20	Stone Inlet Protection and Berm - Type M Inlet .....	103
4-21	Alternate Stone Inlet Protection for Type M Inlet - at Grade .....	104
4-22	Alternate Type C Inlet Protection - Not at Grade .....	105
4-23	Alternate Type M Inlet Protection - Not at Grade.....	106
4-24	Alternate Stone Inlet Protection - Type M Inlet Above Grade .....	107
6-1	Vegetated Channel.....	146
6-2	Sodded Channel.....	148
6-3	Riprap Channel.....	149
6-4	Top-of-Slope Berm .....	151
6-5	Temporary Slope Pipe .....	155
6-6	Bench Detail .....	158
7-1	Skimmer .....	167
7-2	Skimmer Attached to a Permanent Riser .....	168
7-3	Skimmer with Stone Landing Berm.....	170
7-4	Sediment Basin Embankment and Spillway Details - Skimmer .....	171

<b>Detail Number</b>	<b>Name</b>	<b>Page</b>
7-5	Trash Rack and Anti-vortex Device .....	180
7-6	Sediment Basin Embankment and Spillway Details - Perforated Riser .....	181
7-7	Sediment Basin Temporary Riser .....	183
7-8	Sediment Basin/Detention Pond Embankment and Spillway Details .....	185
7-9	Sediment Basin/Detention Pond Riser Structures .....	188
7-10	Temporary Extension Riser and Trash Rack for Permanent Structure .....	190
7-11	Dry Sediment Basin Temporary Riser .....	191
7-12	Sediment Basin Emergency Spillway with Riprap Liner .....	193
7-13	Sediment Basin Emergency Spillway with TRM Liner .....	194
7-14	Baffle .....	201
7-15	Metal Anti-seep Collar for Temporary Basins or Traps.....	207
7-16	Concrete Anti-seep Collar for Permanent Basins or Traps.....	208
7-17	Concrete Cradle for Basin or Trap Outlet Barrel.....	210
7-18	Sediment Basin or Sediment Trap Sediment Storage Dewatering Facility .....	211
8-1	Embankment Sediment Trap .....	215
8-2	Barrel/Riser Sediment Trap.....	218
8-3	Sediment Trap Temporary Riser .....	220
8-4	Dry Barrel/Riser Sediment Trap .....	221
8-5	Dry Sediment Trap Temporary Riser .....	223
8-6	Sediment Trap Outlet Basin Detail .....	225
8-7	Type M Inlet Sediment Trap.....	226
8-8	Concrete Riser with Temporary Dewatering Holes.....	227
9-1	Riprap Apron at Pipe Outlet with Flared End Section or Endwall .....	234
9-2	Riprap Apron at Pipe Outlet without Flared Endwall.....	235
9-3	Riprap Apron at Pipe Outlet to an Existing Channel .....	237
9-4	Stilling Basin .....	246
9-5	Earthen Level Spreader .....	254
10-1	Typical On-lot BMPs for Lot Above Roadway.....	257
10-2	Typical On-lot BMPs for Lot Below Roadway .....	258
10-3	Typical On-lot BMPs for Lot Along Ascending or Descending Roadway .....	259
11-1	Erosion Control Blanket Installation .....	274
13-1	Typical Utility Line Flumed Stream Crossing with Optional Access Road.....	287
13-2	Typical Utility Line Stream Crossing with Pump Bypass.....	288
13-3	Typical Utility Line Stream Crossing with Cofferdam .....	289
13-4	Typical Trench Plug Installation .....	291

# CHECKLISTS, STANDARD E&S WORKSHEETS, STANDARD NOTES AND REFERENCES

Worksheet Number	Name	Page
	Complete Plan Checklist.....	355
	Standard E&S Control Plan Technical Review Checklist.....	357
	Expanded E&S Control Plan Technical Review Checklist.....	360
1	Compost Filter Socks.....	372
2	Compost Filter Berms.....	373
3	Standard Silt Fence.....	374
4	Reinforced Silt Fence.....	375
5	Silt Fence Reinforced by Staked Straw Bales.....	376
6	Super Silt Fence.....	377
7	Straw Bale Barriers.....	378
8	Rock Filters.....	379
9	Time of Concentration.....	380
10	Rational Equation.....	381
11	Channel Design Data.....	382
12	Sediment Basin Capacity Requirements.....	383
13	Sediment Basin Dimensions and Elevations.....	384
14	Sediment Basin/Sediment Trap Storage Data.....	385
15	Sediment Basin/Sediment Trap Dewatering Discharge Data.....	386
16	Sediment Basin Dewatering Time Data.....	387
17	Sediment Basin Discharge Capacity.....	388
18	Anti-seep Collar Design.....	389
19	Sediment Trap Design Data.....	390
20	Riprap Apron Outlet Protection.....	391
21	Temporary and Permanent Vegetative Stabilization Specifications.....	392
22	Plan Preparer Record of Training and Experience in Erosion and Sediment Pollution Control Methods and Techniques.....	393
	Standard E&S Plan Notes.....	394
	References.....	560

## INTRODUCTION (Adapted from the Delaware Erosion and Sediment Control Handbook)



“What is the harm if a little mud washes into the stream?” “Erosion takes place all the time naturally, so what’s the big deal?” “Do you know how much money these erosion control BMPs are costing me?” These are questions that earthmovers ask us all the time. They are legitimate questions that deserve an answer. First, let’s look at the natural process of erosion, then how it is affected by earthmoving projects, and finally how that affects both the environment and all of us as residents and tax payers.

Soil erosion is the process by which the land’s surface is worn away by the action of wind, water, ice and gravity. Natural or geologic erosion has been occurring at a relatively slow rate since the earth was formed, and is a tremendous factor in the creation of the earth as we know it today. The rolling hills of the Allegheny Plateau, the steep slopes of the Valley and Ridge Province, and the relatively low profile of the Coastal Plain are all results of the geologic erosion and sedimentation process in Pennsylvania. Except for some cases of shoreline and stream channel erosion, natural erosion occurs at a slow rate and is an important factor in maintaining an ecological balance.

Water-generated erosion is the most severe type of erosion, especially in developing areas. It is this type of erosion that is the focus of this manual. Water-generated erosion occurs as a result of the impact of rain droplets on unprotected soil surfaces and is due to frictional forces on soil particles as those rain droplets combine and move across the surface of the land. The force due to impact of raindrops is primarily vertical and tends to detach soil particles, while the force of flowing water is primarily horizontal and acts to move detached particles from one place to another.

### **TYPES OF EROSION**

Water-generated erosion can be broken down into the following types:

Raindrop Erosion is the initial effect of a rainstorm upon the soil. Raindrop impact dislodges soil particles and splashes them into the air (See Figure I.1). These detached particles are then vulnerable to the following types of erosion.

Sheet Erosion is caused by the shallow flow of water over the land’s surface before it concentrates. Although seldom the detaching agent, it can transport soil particles detached by raindrop impact.

Sheet erosion has been identified as a major cause of soil loss on agricultural fields. Although there



Plant & Soil Sciences elibrary

**Figure I.1 Raindrop Impact**

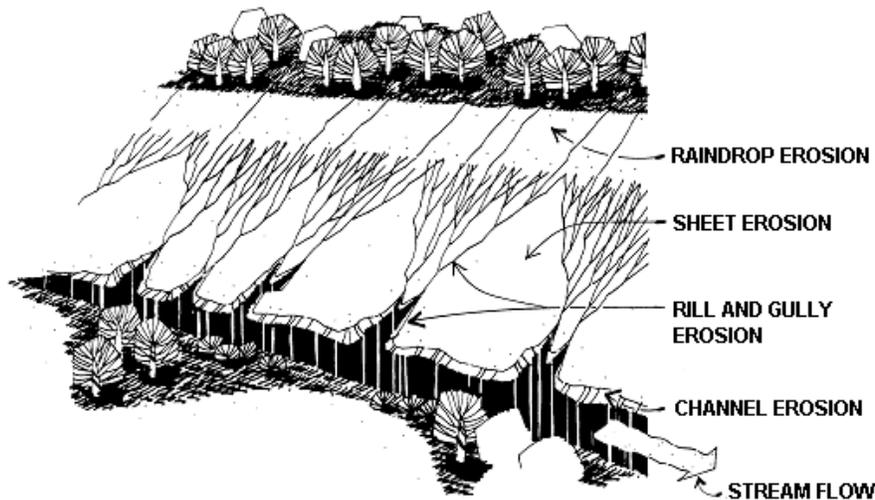


are cases where sheet flow has occurred for distances up to 150 feet, this is rare in Pennsylvania. Surface irregularities typically cause concentration of the flow in less than 30 feet.

Rill Erosion occurs as sheet flow begins to concentrate in the low spots of irregular surfaces. As flow changes from sheet flow to shallow concentrated flow, velocity and turbulence of flow increase. The energy of this concentrated flow is able to detach and transport additional soil particles. When this occurs, the running water begins to cut small channels. Rills are small but well-defined channels up to a few inches deep. They are easily removed by harrowing and other surface treatments.

Gully Erosion occurs when rills combine to form larger and deeper channels. The main difference between rill erosion and gully erosion is magnitude. Gullies are often too large to be repaired by tillage equipment and typically require heavy equipment and special repair techniques.

Channel Erosion takes place when the volume and velocity within a stream channel are such that bed and/or bank materials are moved and not replaced. Figure I.2 illustrates the five stages of erosion.



NRCS

Figure I.2 Types of Erosion

## **FACTORS AFFECTING EROSION**

The erosion potential of any surface is determined by four basic factors: soil characteristics, vegetative cover, topography, and climate. Although each factor will be addressed separately in this section, they are inter-related in determining erosion potential.

SOIL CHARACTERISTICS which influence soil erodibility are those which affect infiltration capacity and resistance to detachment by falling or flowing water. The most important of these characteristics are:

1. Soil Texture (particle size and gradation)
2. Percentage of organic content
3. Soil Structure
4. Soil Permeability

Soils with high percentages of fine sand and silt content are usually the most erodible. Increasing the clay and organic matter content of these soils decreases their erodibility. Clays tend to bind soil particles together, while soils having high organic matter have a more stable structure which improves permeability. Such soils resist detachment due to raindrop impact and tend to infiltrate more rainwater. Reduced runoff results in decreased erosion. Clear, well-drained and well-graded gravel and gravel-sand mixes are usually the least erodible soils.

VEGETATIVE COVER is extremely important in controlling erosion, because it provides the following benefits:

1. It shields the soil surface from raindrop impact.
2. Root systems hold soil particles in place.
3. The soil's capacity to absorb water is maintained.
4. Runoff velocity is reduced.
5. Evapotranspiration reduces subsurface water between rainfalls.

Soil erosion and the resultant sedimentation can be significantly reduced by decreasing the extent of existing vegetation removed and staging construction to reduce the duration of exposure. Special attention should be given to maintaining existing vegetation in areas having high erosion potential such as erodible soils, steep slopes, drainage courses, and streambanks.

TOPOGRAPHY The volume and rate of runoff are affected by the size, shape, and slope of a watershed. Increasing slope length and gradient increases the rate of runoff as well as the potential for erosion. Slope orientation can also influence erosion potential. For example, a south-facing slope having droughty soils may have poor growing conditions that make achieving an erosion-resistant vegetative cover difficult.

CLIMATE The frequency, intensity, and duration of rainfall events are important factors influencing the amount of runoff produced in a given watershed. Increased volume and velocity of runoff result in increased erosion potential. Where storms are frequent and intense or are of long duration, erosion risks are high. Seasonal changes in temperature, as well as variations in rainfall, help define the high erosion risk periods of each year. Precipitation falling as snow does not usually result in erosion. However, when the snow melts, and runoff occurs, erosion hazards can be high. Partially frozen soil has reduced absorption capacity, and while frozen soils are relatively erosion-resistant, soils with high moisture content are subject to uplift by freezing action. This makes them vulnerable to erosion upon thawing.

### **SEDIMENTATION**

During a typical storm event, runoff rapidly increases to a peak and then diminishes. Soil particles are eroded and transported during the higher flows. As velocity decreases, the capacity of the flowing water to transport sediment decreases and some of the soil particles are deposited. Often, these particles are picked up once again by subsequent peak flows. In this way, eroded soil can be transported great distances downslope, or downstream, in intermittent fashion from their source. This process is called *sedimentation*.

A certain amount of sedimentation occurs in all stream channels. This natural process operates in dynamic equilibrium. However, when human activity changes the sediment load and/or the hydrology of a watershed, the stream channel is no longer in equilibrium. Over time, the stream channel will adjust to the changes. The size and shape of the channel will be revised to bring the system back into equilibrium. Where this results in channel erosion, additional material will be transported to downstream receiving waters affecting their equilibrium. Potential environmental and economic impacts due to this process of sedimentation will be discussed later.

### **EROSION AND SEDIMENTATION PROBLEMS ASSOCIATED WITH CONSTRUCTION SITES**

Land development activities often expose soils to the erosive forces of water through precipitation and stormwater runoff. The shaping of land for construction or development purposes removes the soil's protective cover and changes the characteristics of the soil itself in many ways that are often detrimental to infiltration, runoff patterns, and stream flow characteristics. Protective vegetation is reduced or eliminated, topsoil is removed and stockpiled, and cuts and fills are made, altering the topography and runoff characteristics of the site. This can increase the rate at which erosion takes place to 10 or many more times the natural rate, depending on site conditions. Even when the topsoil

is replaced following earthmoving, the physical properties of the soil have been changed. Surrounding properties as well as receiving waters can be adversely affected, even by projects of limited size. Uncontrolled runoff and the resulting sediment pollution can cause considerable economic damage to individuals and to society, in general. Lost water usages, damage to public and private facilities and water supplies, increased flooding, hazards to river traffic, and lost time, effort and money to remediate these problems are all attributable to sediment pollution.

While the benefits of development are desirable, there are some very serious potential hazards associated with that development which should be addressed. These include:

1. A significant increase in exposure of soil to erosive forces during construction
2. Increased volumes of stormwater runoff, accelerated erosion and sediment yield, and higher peak flows caused by:
  - a. Removal of protective vegetative cover
  - b. Exposure of underlying soil or geologic formations which are less permeable and/or more erodible than the original surface soil
  - c. Reduced capacity of soils to absorb rainfall due to compaction by heavy equipment
  - d. Enlarged drainage areas caused by grading operations, street construction, and stormwater conveyance facilities
  - e. Prolonged exposure of disturbed areas due to scheduling and/or sequencing problems
  - f. Reduced times of concentration of surface runoff due to steepened slopes, shortened flow paths, and use of materials with low resistance to flow
  - g. Increased impervious surface areas due to construction of streets, buildings, sidewalks, and parking lots
3. Alteration of the groundwater regime, which adversely affects drainage systems, slope stability, and survival of vegetation
4. Exposure of subsurface materials that are rocky, acidic, droughty, or otherwise unfavorable to the establishment of vegetation
5. Adverse alteration of surface runoff patterns

Although streams and rivers naturally carry sediment loads, sediment yields from construction sites can elevate these loads well above those in undisturbed watersheds. The erosion rates from construction sites are generally acknowledged to be much greater than from almost any other land use. Both field studies and erosion models indicate that erosion rates from construction sites are typically an order of magnitude larger than row crops, and several orders of magnitude greater than well-vegetated forests and pastures (USDA, 1970, cited in Dillaha et al., 1982; Meyer et al., 1971). Wolman and Schick (1967) studied fluvial systems in Maryland and found sediment yields in areas undergoing construction to be 1.5 to 75 times greater than in natural or agricultural catchments. A highway construction project in West Virginia disturbed only 4.2% of a 4.75 square mile basin, but this resulted in a three-fold increase in suspended solids (Downs and Appel, 1986).

## **ENVIRONMENTAL IMPACTS OF SEDIMENT**

Stormwater discharges generated during construction have a potential for serious water quality impacts. The biological, chemical, and physical properties of the waters may be severely affected. A number of pollutants are often absorbed into the mineral or organic particles that comprise sediment. The erosion and transportation of sediment into aquatic ecosystems is the primary pathway for delivering nutrients (especially phosphorus), metals, and organic compounds. According to the Pennsylvania Fish and Boat Commission, "Sediment pollution in lakes, reservoirs and bays can introduce excess nutrients resulting in algal blooms; block the amount of available sunlight for aquatic plants; reduce water depth resulting in warmer water temperatures; and speed up the water bodies natural aging process (eutrophication)." It has been estimated that 80% of the phosphorus and 73% of the Kjeldahl nitrogen in streams is associated with eroded sediment (USDA, 1989, cited in Fennessey and Jarrett, 1994). Sediment can also act as a long-term storage media for toxicants. Studies show that pollutants such as DDT, DDE, PCBs and chlordane can be found at detectable levels in sediment deposited years ago at the bottoms of streams and rivers.

Where construction activities are intensive, the localized impacts upon water quality can be severe due to high pollutant loads, primarily sediment. By volume, sediment is the greatest pollutant to the surface waters of Pennsylvania. Excess sediments are associated with increased turbidity and reduced light penetration in the water column, as well as more long-term effects associated with habitat destruction and increased difficulty in filtering drinking water. In addition to reducing light penetration, fine sediment (fine sand and smaller) impedes sight-feeding, smothers benthic organisms, abrades gills and other sensitive structures, reduces habitat by clogging interstitial spaces within a stream bed, and reduces the intergravel dissolved oxygen by reducing the permeability of the bed material. The overall effect of fine sediment is to drastically reduce both the kinds and numbers of organisms present.

Coarser-grained materials blanket bottom areas and suppress aquatic life found in these areas. Where currents are strong enough to move bedload, the abrasive action of suspended sediment accelerates channel scour. Introduction of large volumes of sediment also has the potential of filling lakes and reservoirs as well as clogging stream channels.

According to the U.S. Environmental Protection Agency (EPA), sediment is the primary stressor for 31% of all declared impaired stream miles in the United States.

### **ECONOMIC IMPACTS OF SEDIMENT**

It has been estimated that over four billion tons of sediment reach the ponds, rivers, and lakes of the United States each year, and approximately one billion tons of this sediment eventually reaches the ocean. Sediment entering small streams in upland areas can be carried downstream into larger, navigable rivers and reservoirs necessitating costly dredging. Every year in the United States about 497 million cubic yards of material are dredged by the U.S. Army Corp of Engineers and private operators to create and maintain navigable waterways and harbors. Without such efforts, many waterways and port facilities would soon become impassable by most large commercial and defense vessels. The cost of keeping these waters passable is approximately \$500 million dollars annually (1986 dollars). In addition, the disposal of dredged material has become increasingly difficult with the dwindling supply of suitable sites available.

According to the Philadelphia Water Department, sediment pollution can increase the cost of water filtration for public drinking water. Sediment pollution, according to Pennsylvania Fish and Boat Commission and Trout Unlimited, costs Commonwealth residents tens of millions of dollars each year in lost revenue (e.g. hotel rooms, restaurants, etc.) associated with recreational fishing because of degraded water quality and reduced fish habitat. Other forms of tourism that may suffer include hiking, swimming and sightseeing.

Sediment deposition can contribute to accelerated streambank erosion which translates into property losses for public and private property owners.

In 1985, a study by Clark, et. al., estimated that the annual cost of sediment damage in the United States ranged from \$1 billion to \$13 billion (\$2.1 billion and \$27.3 billion in 2011 dollars\*). Another study by Osterkamp, et. al. found that the annual costs of water pollution due to sediment in North America approached \$16 billion in 1988 (\$31 billion in 2011 dollars\*). It is clear from these studies that the economic damage due to sediment pollution is significant. It is also clear that the benefits of sound erosion control practices during earthmoving operations not only make good sense from an environmental viewpoint, but from an economic one as well.

\* Adjusted according to the Consumer Price Index

## CHAPTER 1 - REQUIRED E&S PLAN CONTENT

Pa. Code Title 25 Chapter 102.4 (b) requires the “implementation and maintenance of E&S BMPs” to minimize the potential for accelerated erosion and sedimentation, including those activities which disturb less than 5,000 square feet (464.5 square meters)” [102(b)(1)]. It also requires that “a person proposing earth disturbance activities shall develop and implement a written E&S Plan under this chapter if one or more of the following criteria apply [102.4(b)(2)]:

1. The earth disturbance activity will result in a total earth disturbance of 5,000 square feet (464.5 square meters) or more,
2. The person proposing the earth disturbance activities is required to develop an E&S Plan under this chapter or under other Department regulations, or
3. The earth disturbance activity, because of its proximity to existing drainage features or patterns, has the potential to discharge to a water classified as a High Quality or Exceptional Value water under Chapter 93 (relating to water quality standards)..”

§102.4(b)(3) requires that the E&S Plan “be prepared by a person trained and experienced in E&S control methods and techniques applicable to the size and scope of the project being designed.”

§102.4(b)(4) requires that “unless otherwise authorized by the Department or conservation district after consultation with the Department, earth disturbance activities shall be planned and implemented to the extent practicable in accordance with the following:

1. Minimize the extent and duration of the earth disturbance.
2. Maximize protection of existing drainage features and vegetation.
3. Minimize soil compaction.
4. Utilize other measures or controls that prevent or minimize the generation of increased stormwater runoff.”

Perhaps the most neglected and yet the most important aspect of designing an effective E&S plan is knowledge of the specific site in question. It is essential that the plan designer have as complete an understanding of the unique characteristics of the site as possible. Therefore, it is highly recommended that a site visit be scheduled at the earliest practical point in the development of the plan.

Site characteristics that will affect the plan design as well as the construction of the project (e.g., drainage patterns, seeps and springs, steepness and stability of slopes, sinkholes, etc.) should be noted and mapped. Sensitive and special value features (e.g., wetlands, woodlands, flow paths, riparian areas, etc.) should be identified, mapped, and protected as much as possible. A little time well spent in the field can save much time and money due to plan revisions, unforeseen hazards, penalties, and shutdowns. Only after the designer has a good working knowledge of the site should the designer proceed with developing the E&S plan.

The basic concept of providing effective, efficient and practical erosion and sediment control should be considered when determining the locations and types of BMPs. All off-site surface water should be diverted away from areas to be disturbed (wherever feasible); all runoff from disturbed areas should be collected and conveyed to a sediment basin, sediment trap, or other BMP for sediment removal. The extent of the disturbance, as well as the time period between initial disturbance and final stabilization, should be minimized. Existing vegetation, especially existing trees, should be preserved wherever possible (see Appendix I for more information regarding tree preservation). Temporary stabilization must be provided for earth-exposed areas where earthwork is delayed or stopped for a period of 4 or more days, and permanent stabilization must ultimately be provided for all disturbed areas (25 Pa Code § 102.22). Sediment removal treatment for water pumped from excavations is usually needed. Access to the site and removal of mud from vehicle tires before vehicles exit onto existing roadways — public or private — are also required.

25 Pa. Code § 102.4(b)(5) of the Pennsylvania Code requires that the following items be included in the drawings and narrative of an E&S plan for earth disturbance activities:

1. ***The existing topographic features of the project site and the immediate surrounding area.*** These features should be shown on a map or maps included with or part of the drawings. This requirement applies to off-site borrow and waste areas as well as the project site. Mapping should conform to the standards contained in Appendix D. Cross-sections and profiles are not an acceptable alternative since these do not adequately define existing level contour for sediment barriers or drainage areas for channels, basins, or traps.
2. ***The types, depth, slope, locations and limitations of the soils.*** The locations of the soils may be delineated on the map or drawing discussed above, or on a separate map of the site. A legible photocopy of a portion of the soil survey maps on which the proposed project can be clearly shown may also be used. The locations of all proposed sediment basins and traps should be shown on any separate or soil survey maps.

The types, depth, slope and limitations of the soils should be included in the narrative portion of the plan or on the plan drawings/maps. Data on the physical characteristics of the soils, such as their texture, resistance to erosion and suitability for intended use is to be included in the narrative report. This information is available from the tables on the USDA, Natural Resources Conservation Service website: <http://websoilsurvey.nrcs.usda.gov/app/WebSoilSurvey.aspx>. Soils information is also available from the Penn State website at: <http://soilmap.psu.edu>. However, the data from the Penn State website might not be as current as that from the NRCS website, and, therefore, it should only be used if the county survey has not been updated.

Only those limitations relevant to the proposed project should be cited (e.g. suitability for corn production would not be appropriate for a housing project, but soil erodibility, slope stability, suitability for winter grading, piping tendencies, and potential trench caving would be appropriate). Appendix E lists some of the most common soil use limitations for many of the soils in Pennsylvania. The means to address the identified soils limitations should be included on the drawings. For example, a note to use only certain areas of the site as sources for embankment material for sediment basins or traps, or special fertilization requirements for portions of the project, etc. The intent of Appendix E is to alert designers to potential problems that could arise during construction and afford an opportunity to avoid or minimize those problems by proper design. Simply copying Appendix E into the narrative is not sufficient to meet the requirements of this section.

3. ***The characteristics of the earth disturbance activity, including the past, present and proposed land uses and the proposed alteration to the project site.*** Past land uses are the actual land use(s) of the project site for the past 50 years or longer if known, not just the zoning of the land. Present land uses are the dominant land uses of the project site for the 5 years preceding the planned project, not just the zoning of the land. For sites requiring a National Pollutant Discharge Elimination System (NPDES) permit, this information is contained in the completed Notice of Intent (NOI). For non-permitted sites, it should be included in the narrative. Site design and layout should employ an environmentally sensitive approach that minimizes the effect of the development on water, land, and air to the maximum extent practicable. The guidelines for Non-Structural BMPs set forth in Chapter 5 of the Department's Pennsylvania Stormwater Best Management Practices Manual (Document No. 363-0300-002) should be incorporated prior to design of the E&S plan. The proposed alteration to the project area and the limits of the project area should be shown on maps or drawings. These maps should be at the same scale as the original topographic map. The use of the original contour map as a base map, with the new contours superimposed and identified in the legend, should be used to depict the alteration to the area. Such information as the limits of clearing and grubbing, the areas of cuts and fills and the locations of roads, paved areas, buildings and other structures are to be included. Final contours of the project area at an interval that will adequately describe the

topography of the site should be included on these maps. Final contours should tie into existing contours. Separate maps/drawings, or inserts on the main project drawings should be included for off-site borrow or disposal areas which are part of the project. These drawings or inserts should include all information required on the main drawings. A legend that describes all of the alterations and BMPs to be used for erosion and sediment control should be shown on the maps or drawings. Proposed grading should conform to the standards provided in Chapter 16 of this manual.

4. ***The volume and rate of runoff from the project site and its upstream watershed area.*** The area draining to a particular BMP should be determined. Acceptable methods to calculate runoff are described in Chapter 5 of this manual and Chapter 8 of the Pennsylvania Stormwater Best Management Practices Manual. In some instances the drainage areas will increase or decrease as the site grading proceeds. In either case, the maximum drainage area to the BMP should be used to determine the design capacity. Design capacity requirements are included in the descriptions for the various BMPs. It should be noted that “due to the limitations of the Rational Method itself, as well as assumptions in the Modified Rational Method about the total storm duration, this method may not be used to calculate water quality, infiltration, or capture volumes for Post Construction Stormwater Management BMPs” (Pennsylvania Stormwater Best Management Practices Manual, 2006).

For many projects, alterations to drainage patterns, impervious coverage or other watershed characteristics may necessitate an Off-Site Stability Analysis. This analysis is necessary where stormwater discharges are proposed to be directed to off-site areas that are not Surface Waters (i.e. uplands) or to areas unsuitable for carrying storm event flows. This can include overland flows that discharge to an open area, or follow an existing swale or other natural flow path lacking clearly defined bed and banks. For more guidance on these discharges, see Appendix G - Technical Paper: “Level Spreaders and Off-site Discharges of Stormwater to Non-surface Waters”. Specific guidance for determining adequacy of discharge can be found under the section on *Legal Considerations*. Further guidance can be obtained from the Department’s factsheet regarding “Off Site Discharges of Stormwater to Areas that are not Surface Waters” (Document No. 3930-FS-DEP4124).

A stream stability analysis is necessary where discharges are anticipated to overburden a receiving stream, most notably headwater streams which are typically the least tolerant to increases in magnitude, duration or frequency of discharges. Wherever a proposed discharge will result in a discernible increase in rate or volume to a receiving waterway, a stream stability analysis should be included in the narrative stating the impact of the discharge on the watercourse’s ability to resist erosion. Design computations for all proposed protective measures for downstream watercourses should be included. (See Chapter 6 for guidance on calculating channel capacity and checking the stability of existing or proposed linings). Additional guidance and information regarding stream channel stability analysis may also be obtained from Technical Bulletin No. 1 - “Stream Channel Erosion Control Policy Guidance” from Virginia Department of Conservation and Recreation ([http://www.dcr.virginia.gov/stormwater\\_management/documents/tecbltn1.PDF](http://www.dcr.virginia.gov/stormwater_management/documents/tecbltn1.PDF)).

5. ***The location of all surface waters, which may receive runoff within or from the project site and their classification under Chapter 93.*** All streams in Pennsylvania are classified based on their designated and existing water uses and water quality criteria. Designated uses for surface waters are found in 25 Pa. Code §§ 93.9a—93.9z. Existing uses of surface waters are usually the same as the designated use, except where information has been provided to or obtained by the Department, which indicates that a particular water body actually attains a more stringent water use than the designated use. Existing uses are protected pursuant to 25 Pa. Code §§ 93.4a—93.4c. Existing uses may be obtained from DEP’s website at: <https://www.pa.gov/agencies/dep/programs-and-services/water/clean-water/water-quality/stream-redesignations/statewide-existing-use-classifications.html>. If the runoff from a

permitted project site discharges to a stream that is classified for special protection (High Quality [HQ] or Exceptional Value [EV]), more stringent criteria are to be used to design the BMPs for that site. Nondischarge alternatives are to be used wherever possible. If during a 2-year/24-hour storm event it is not possible to avoid increasing the rate or volume of runoff from disturbed areas to a special protection watershed, Antidegradation Best Available Combination of Technologies (ABACT) BMPs must be used to the fullest extent possible. BMPs with low sediment removal efficiencies (e.g. rock filters) are not ABACT. BMPs with moderate sediment removal efficiencies (e.g., barrel/riser sediment traps) are ABACT for HQ watersheds, but not EV watersheds. BMPs with high sediment removal efficiencies (e.g. compost filter socks) are ABACT for HQ and EV watersheds. The BMPs contained in this manual are rated in the sections where those BMPs are addressed. A list of acceptable ABACT is provided in Chapter 17. Some of the criteria for common erosion control BMPs to meet ABACT requirements are listed here for emphasis:

- (i) Special Sediment Basin Requirements
  - (a) Principal spillways should be designed to skim water from the top 6 inches of the dewatering zone, or have permanent pools greater than or equal to 18 inches deep.
  - (b) The basin should be designed with a flow length to average basin width ratio of 4L:1W or greater.
  - (c) The basin should be designed such that the settling volume dewateres in no less than 4 days and no more than 7 days when at full capacity (i.e. top of the settling volume, elevation 3 on Standard E&S Worksheet # 13 to top of sediment storage elevation, elevation 2 on Standard E&S Worksheet # 13).
- (ii) Channels, collectors, and diversions should be lined with permanent vegetation, rock, geotextile, or other non-erosive material.
- (iii) Temporary BMPs that divert or carry surface water should be designed to have a minimum capacity to convey the peak discharge from a 5-year frequency storm.
- (iv) Upon completion or temporary cessation of the earth disturbance activity, or any stage thereof, the project site shall be immediately stabilized.
- (v) The Department may approve alternate BMPs that will maintain and protect existing water quality and existing and designated uses.

Where it can be shown that the use of flocculants can help to meet effluent standards, and that the use of such flocculants, consistent with the manufacturer's recommendations, does not in itself pose a threat to water quality, their use can be approved on a case-by-case basis.

**6. *A narrative description of the location and type of perimeter and on site BMPs used before, during, and after the earth disturbance activity.***

For permitted sites, this description is provided when the NOI is properly completed. Otherwise it should be included in the narrative.

**7. *A sequence of BMP installation and removal in relation to the scheduling of earth disturbance activities, prior to, during and after earth disturbance activities that ensure the proper functioning of all BMPs.***

The plan drawings should include a complete schedule of installation and removal of erosion control BMPs as they relate to the various phases of earthmoving activities. A good sequence will minimize the time of disturbance without unnecessarily restricting the construction process. The sequence should be site-specific and address all proposed erosion control and stabilization



BMPs. Appropriate BMPs for sediment pollution control should be in place and functional before earth disturbance occurs within a given drainage area. All of the steps to be taken from the initial site clearing through the final stabilization of the site should be included. A stabilized construction entrance is often installed as a first item of work on a given site. Other BMPs are constructed when needed to accommodate the planned sequence of project installation. Chapter 2 provides additional guidance on BMP sequencing.

8. ***Supporting calculations and measurements.*** All design information for all proposed BMPs (including outlet channels from proposed basins, traps, and stormwater outfall protection) should be included in the narrative report. This information will vary according to the BMP, but may include such information as the drainage area, anticipated flow rate, velocity and the proposed method of stabilization. The standard worksheets, included in Appendix B of this manual, give guidance for the design calculations and information required. Use of these standard worksheets is recommended in order to expedite plan reviews. Failure to provide all of the information requested by the appropriate worksheet(s) will constitute a plan that is administratively incomplete. These worksheets may not be altered in form or content unless prior approval is obtained from the reviewing agency.
9. ***Plan drawings.*** The locations of the BMPs should be shown on the map(s) described earlier. A legend, describing all symbols should be included on all plan maps or drawings. Proposed new contours should tie into existing contours. All construction details and specifications for the facilities should be included on the drawings. Typical sketches may be used. However, these sketches should provide sufficient detail to show critical dimensions and construction details.

Standard construction details may be copied from this manual and inserted into the E&S plan drawings of specific projects. It should be noted that many of these standard details have attached notes in bold type. These notes should be considered part of that detail and included on the plan drawings. Construction details that have been altered in form or content may not be labeled "Standard Construction Detail." Many of the standard construction details and standard worksheets contain tables of dimensions that should be copied onto the E&S plan drawings.

Appendix C contains standard notes that should be placed on the plan drawings. Optional notes are also provided and should be used where appropriate. Additional notes may be added as needed so long as they do not contradict the standard notes, details, sequence, or maintenance requirements.

10. ***A maintenance program that provides for the operation and maintenance of BMPs and the inspection of BMPs on a weekly basis and after each stormwater event, including the repair or replacement of BMPs to ensure effective and efficient operation. The program must provide the completion of a written report documenting each inspection and all BMP repair or replacement and maintenance activities.*** A maintenance program for both the temporary and permanent erosion and sediment control BMPs, including disposal of materials removed from the BMPs or project area, should be included on the plan drawings. The maintenance program should include a schedule for inspection of the various BMPs that provides for inspection after each runoff event as well as on a weekly basis. The type of maintenance, such as cleanout, repair, replacement, regrading, restabilizing, etc. for each of the BMPs should be included on the plan drawings. For sediment basins and traps, the elevation corresponding to top of sediment storage level should be specified and a means to identify this elevation should be identified. The means of disposal of the materials removed from the BMPs should also be specified. If materials removed from the BMPs are to be removed from the project area, the site and method of disposal should be indicated. Guidance on appropriate maintenance actions is provided for each BMP described in this manual.

11. ***Procedures which ensure that the proper measures for the recycling or disposal of materials associated with or from the project site will be undertaken in accordance with Department regulations.*** Individuals responsible for earth disturbance activities must ensure that proper mechanisms are in place to control waste materials. Construction wastes include, but are not limited to, excess soil materials, building materials, concrete wash water, sanitary wastes, etc. that could adversely impact water quality. Measures should be planned and implemented for housekeeping, materials management, and litter control. Wherever possible, recycling of excess materials is preferred, rather than disposal. A note requiring recycling of waste materials, where feasible, should be added to the drawings.
12. ***Identification of the natural occurring geologic formations or soil conditions that may have the potential to cause pollution during earth disturbance activities and include BMPs to avoid or minimize potential pollution and its impacts from such formations.*** Geologic formations containing minerals (e.g. pyrite) in sufficient quantities that could result in discharges which do not meet water quality standards for the receiving surface water(s) must be identified. The locations of the formations containing those minerals (if not site wide) should be shown on the plan maps. Appropriate measures to prevent such discharges (including but not limited to, proper handling, isolation, disposal, etc.) should be provided on the plan drawings along with typical details illustrating the procedures and/or BMPs to be used.

Bedrock or soil conditions which could result in significant slope failures resulting in mass soil movement into surface waters, property damage, or a public safety hazard should also be identified. The erosion control plan narrative should briefly state the methods incorporated into the plan which address such hazards. Plan maps should clearly mark the locations where potential for slope failures exist, and appropriate construction details and typical details should be provided on the plan drawings.
13. ***Identification of potential thermal impacts to surface waters of this Commonwealth from the earth disturbance activity including BMPs to avoid, minimize or mitigate potential pollution from thermal impacts.*** An analysis of how thermal impacts associated with the project will be avoided should be provided. If thermal impacts cannot be avoided, describe how impacts were minimized and the BMPs that will mitigate the impacts in a manner that will protect and maintain water quality in surface waters. Additional information on minimizing thermal impacts can be found in the Pennsylvania Stormwater Best Management Practices Manual.
14. ***The E&S Plan shall be planned, designed, and implemented to be consistent with the Post Construction Stormwater Management (PCSM) Plan under 25 Pa. Code § 102.8 (relating to PCSM requirements). Unless otherwise approved by the Department, the E&S Plan must be separate from the PCSM Plan and labeled "E&S" or "E&S Plan" and be the final plan for construction.*** The overall design of the project must support the management of stormwater for erosion and sediment control during earth disturbance activities in a manner that is compatible with — and can be integrated into— structural and non-structural PCSM practices and approaches.
15. ***Identification of existing and proposed riparian forest buffers.*** When riparian forest buffers will be incorporated into a project site in accordance with 25 Pa. Code § 102.14 as part of the PCSM Plan, the areas of existing buffers or the areas where buffers will be developed should be identified on the plan drawings. Certain restrictions on earthmoving within 150 feet in a special protection watershed and 100 feet in areas where a voluntary riparian buffer will be installed must be met for permitted sites. All proposed earthmoving, including installation of E&S BMPs, must comply with those restrictions.

**E&S Antidegradation Implementation for Special Protection Waters** - Chapter 102.4(b)(6) states, "In order to satisfy the Antidegradation implementation requirements of 25 Pa Code Section 93.4c(b) (relating to implementation of antidegradation requirements), for an earth disturbance activity that requires a permit under this chapter and for which any receiving surface waters of this Commonwealth

is classified as High Quality (HQ) or Exceptional Value (EV) under Chapter 93, the person proposing the activity shall in their permit application:

- (i) Evaluate and include nondischarge alternatives in the E&S plan, unless a person demonstrates that nondischarge alternatives do not exist for the project.
- (ii) If the person makes the demonstration in (i) that nondischarge alternatives do not exist for the project, the E&S plan shall include ABACT (Except as provided in §93.4C(b)(1)(iii)\_(relating to Socio-Economic Justification).”

Section 102.1 defines a nondischarge alternative as “environmentally sound and cost-effective BMPs that individually or collectively eliminate the net change in stormwater volume, rate and quality for storm events up to and including the 2-year/24-hour storm when compared to the stormwater rate, volume and quality prior to the earth disturbance activities to maintain and protect the existing quality of the receiving surface waters of this Commonwealth.” Therefore, an applicant for an NPDES Permit or an ESCP (Erosion and Sediment Control Permit) permit should be able to show no net increase in volume or rate of discharge in the summary table of the NOI for pre- vs. post-construction conditions. This should be supported by Worksheets 1 through 5 from the Pennsylvania Stormwater Best Practices Manual. In addition, Worksheet 10 from the Pennsylvania Stormwater Best Management Practices Manual should show no degradation of water quality.

In HQ watersheds, socio-economic justification (SEJ) for degradation may be provided in accordance with Chapter 93. However, no SEJ is allowable in EV watersheds.

The chapters which follow evaluate specific BMPs as to whether they should be considered ABACT for HQ or EV watersheds. Those with low sediment removal potential are not rated as ABACT. Those with moderate sediment removal potential are rated as ABACT for HQ but not EV watersheds. Only those with high sediment removal potential are rated as ABACT for EV watersheds. It should be understood that a BMP that is not rated as ABACT for an HQ or an EV watershed is not prohibited from use in that watershed. However, it may not be the only BMP used. Non-ABACT BMPs may be used in conjunction with ABACT to increase their efficiency. The Department may also consider whether use of several non-ABACT in a treatment train may constitute an ABACT in effect. Chapter 17 addresses Special Protection Watersheds, Antidegradation, and ABACT in more detail.

While nondischarge alternatives and/or ABACT are not required for non-permitted sites, they are recommended. Site conditions such as proximity to the receiving surface water, steepness of slope, soil conditions, and nature of the project should be considered when determining whether to use these options.

**Alternative BMPs** - The Department may approve alternative BMPs (not contained in this manual, or using a different design method or standards than those described in this manual) that maintain and protect existing water quality and existing and designated uses. However, the burden of proof that the proposed BMPs are appropriate for the intended use lies with the plan designer. Sufficient supporting documentation (calculations, manufacturer’s specs, etc.) should be included with the application to allow the reviewer to make an informed decision. For more information regarding new products and procedures, see Chapter 12.

**Riparian buffers** - Section 102.14 requires persons conducting permitted activities in HQ or EV watersheds to protect, convert, or establish new riparian forest buffers within 150 feet of a perennial or intermittent river, stream, creek, lake, pond, or reservoir. See 25 Pa. Code § 102.14 for additional guidance.

**Additional Information** - The Department or conservation district, after consultation with the Department, may require other information necessary to adequately review a plan, or may require alternative BMPs on a case-by-case basis when necessary to ensure the maintenance and protection of water quality and existing and designated uses. In cases where the Department has already provided guidance regarding the need for additional information, a conservation district may require additional information in accordance with that guidance without consulting with the Department.

## CHAPTER 2 - BEST MANAGEMENT PRACTICE (BMP) SEQUENCING

A BMP sequence is a specified work schedule that coordinates the timing of earthmoving activities and subsequent stabilization with the installation and removal of E&S BMPs or the conversion of those E&S BMPs to PCSM BMPs. The purpose of the sequence is to reduce the potential for accelerated erosion and the resultant sediment pollution to surface waters by ensuring that the BMPs designed to accomplish that are in place and functioning when they are needed. In cases where the earthmoving contractor is known at the time of the application, the contractor should be involved in the development of the sequence to minimize potential conflicts of the proposed sequence with efficient construction practices. Any earthmoving contractor who finds the sequence to be non-feasible, in whole or in part, must obtain written approval from the approving agency prior to altering the sequence.

A BMP sequence must be provided for every earthmoving project requiring a written E&S plan. Since each project differs from all others in some way, the BMP installation sequence must be site specific. It should identify the specific BMPs that will be employed during each stage of construction.

Whenever possible, larger projects should be phased so that only part of the site is disturbed at any one time, thus minimizing sediment being transported from dormant parts of the project. Cuts and fills should be coordinated so that the need for temporary storage of materials is minimized. Ideally, the sequence should be set up according to watershed areas with disturbances limited to one watershed at a time. Where it is not possible to limit disturbance to one watershed at a time, the sequence should clearly identify the BMPs that should be in place and functioning before work progresses into an adjacent watershed. In this way, the contractor may work within the various watersheds, or drainage areas, in whatever order is most efficient, or even simultaneously, so long as the sequence is followed for each watershed or drainage area.

Sequences that require very complicated or restrictive construction practices should be avoided wherever possible. Apparent savings in construction of BMPs can be lost many times over by unrealistic restrictions placed upon the contractor. The simpler the staging requirements, the more likely it is that the contractor will be able to complete the project without stepping outside of the approved sequence. A system of channels and traps or sediment basins usually provides adequate sediment pollution protection while allowing freedom to the contractor to perform the earthmoving in a cost effective manner. Often, these facilities can be converted to PCSM BMPs upon completion of the project.

However, concentrating site runoff into a few large impoundments is not always the best solution to sediment pollution or stormwater management. Consideration should be given to whether several smaller structures could operate more efficiently, at a lower cost, and with less impact on receiving waters than one large one. Managing site runoff close to its source is therefore encouraged.

The BMP installation sequence should be complete, i.e. it should address all aspects of the proposed earthmoving as it applies to erosion and sediment pollution control. The sequence should be a step-by-step outline of the proposed project detailing what BMPs will be installed prior to each stage of construction (including drilling of geothermal wells where applicable, see Chapter 17). Wherever possible, the locations of the control facilities should be specified. An acceptable alternative is to number the BMPs and indicate which numbers are being installed during each step of the sequence.

The sequence should indicate that stabilized construction entrances will be installed wherever it is known that construction vehicles will be exiting onto a roadway (public or private). It should also indicate the necessity of constructing a stabilized construction entrance wherever needed, although not specifically identified by the plan.

Appropriate controls should be installed and functioning prior to clearing and grubbing. Temporary stream crossings must be provided wherever clearing vehicles will be crossing existing stream channels (perennial or intermittent). Initial clearing should be limited to that which is necessary to

install the proposed perimeter BMPs. General site clearing and grubbing should be done only in those areas where suitable BMPs have been installed and are functioning. Progressive clearing and grubbing, beginning in the location of BMPs and support areas, may be used as long as the installation of BMPs keeps pace with the clearing and grubbing. **Note: For permitted sites, the NPDES permit, ESCP permit or ESCGP (Erosion and Sediment Control General Permit for Earth Disturbance Associated with Oil and Gas Exploration, Production, Processing, or Treatment Operations or Transmission Facilities) permit must be obtained prior to beginning clearing and grubbing operations.**

If it is necessary to construct access roads in order to install proposed BMPs, the sequence should address how these access roads will be stabilized. If the access road is to remain in place following completion of any BMP, runoff from the roadway should be directed into an appropriate BMP by means of a waterbar, culvert, broad-based dip, or other drainage control device. The locations of temporary access roads should be shown on the plan maps.

Wherever BMPs will be discharging to proposed storm sewers, the storm sewers should be installed and functioning prior to construction of the BMPs in question. However, care should be taken to avoid conflicts with any proposed cuts or fills in the areas of the proposed storm sewer location.

Wherever it is necessary for construction vehicles to cross a proposed channel, the sequence should specify the installation of a temporary crossing (culvert or bridge if it is a diversion channel, outlet channel or bypass channel; culvert, bridge, or ford for a collector channel).

The sequence should describe how flow/runoff in existing streams or swales will be handled during any proposed culvert (pipe or box) installation. It is recommended that a mini sequence be included along with the installation detail on a detail sheet. The main sequence may refer to the mini sequence without repeating the specifics. The plan should also specify how water pumped from work areas during culvert construction will be handled.

Sequences should specify the controls to be used during construction of any proposed basins or traps. If stream flow will need to be diverted around the work area, the sequence should provide instructions for how this will be accomplished. Note: bypass pipes should be constructed around, not through, basins or traps. The sequence should also describe the proper method of embankment construction and stabilization or refer to the specifications provided elsewhere on the plan drawings.

The sequence should specify the completion of the proposed E&S BMPs (basins, traps, channels, etc.) including any required outlet protection or conveyance channels prior to any general earthmoving within a specific work area.

Runoff should be directed away from outslopes of constructed fills wherever possible. Consideration should be given to use of berms along the tops of fill slopes to direct runoff to temporary slope pipes or groin ditches, which discharge into sediment traps, sediment basins, or collector channels discharging to basins or traps located below the fill. An acceptable alternative is the maintenance of rock chimney drains to rock toe benches, wherever such benches are available and such drainage does not compromise the stability of the fill, the chimney drains can be kept open, and runoff can be directed to the drains.

Anticipated runoff at the cut/fill interfaces should be addressed by the sequence. Since erosion gullies tend to form at these locations, some means of conveying the water downslope should be provided (e.g. catch basins or suitably lined groin ditches).

The sequence should provide specifics about the installation of any proposed sewer lines or utility lines. This information should conform to the standards contained in Chapter 9. If storm sewer inlets (existing or proposed) will need protection, the sequence should indicate when the protection should be

installed. Utility lines that cross traps and basins should be constructed prior to the embankment construction.

The BMP installation sequence must limit exposed areas. As stated above, initial clearing and grubbing should be limited to that which is necessary to construct the proposed perimeter BMPs. Generalized statements such as, "Install all proposed control facilities within XYZ watershed," are not acceptable.

The sequence must require immediate stabilization upon temporary cessation of work —4 days or more — or as soon as any graded area reaches final grade. Waiting for an entire phase to reach final grade before seeding and mulching takes place is not acceptable.

Long, steep cuts and fill slopes should be seeded and mulched in 15' vertical increments. This will provide a little more than 33 feet of slope length for tracking equipment on a 2H:1V slope. If very large equipment is used, the vertical increment may be increased to 20 feet. An acceptable alternative is to construct benches at 30-foot vertical intervals. Fill slopes below each bench should be stabilized upon their completion. Such benches should be designed to provide positive drainage to a suitably stabilized outlet. Otherwise, the sequence should specify seeding and mulching of all completed areas on a periodic —every 7 days or specified number of feet or acres — basis.

The BMP installation sequence should specify the removal of temporary E&S BMPs upon completion and stabilization of the disturbed area tributary to each BMP. Conditions of stabilization should be specified. Vegetated areas must achieve a minimum uniform 70% perennial vegetative cover over the entire disturbed area. Roadways and parking areas should at least have a clean subbase in place.

Any E&S BMPs that are to remain as PCSM BMPs must be modified where necessary to meet the requirements of the permanent facility. If any sediment basins or traps are to be converted to detention ponds, conversion should be restricted to the growing season, and the sequence should describe the procedure to be used. This should include:

- a) Flushing accumulated sediment from the contributing storm sewer system
- b) The method of dewatering the impoundment
- c) Removal and proper disposal of accumulated sediment
- d) Removal of all other temporary facilities such as baffles, cleanout stakes, dewatering facilities etc.
- e) Sediment protection of permanent orifice or weir until interior of permanent facility is stabilized
- f) Removal of the temporary riser and the installation/opening of the permanent riser.
- g) Stabilization of the interior of the impoundment as well as steps necessary to provide any proposed infiltration capacity

Installation of PCSM BMPs not used as temporary E&S BMPs should be scheduled for after the areas tributary to them have been stabilized. Wherever this is not possible, the PCSM BMPs should be protected from sediment-laden runoff. Failure to adequately protect PCSM BMPs from sediment deposition will require rehabilitation to restore them to proper functioning.

Maintenance information should not be included in the BMP sequence. All maintenance information should be contained in the maintenance section of the plan drawings or adjacent to the construction

detail(s) for the specific BMP. In addition, maintenance information should be included in the operation and maintenance plan for the project.

It is recommended that the following standard notes be placed immediately prior to the sequence on the plan drawings for permitted sites:

1. At least 7 days prior to starting any earth disturbance activities (including clearing and grubbing), the owner and/or operator shall invite all contractors, the landowner, appropriate municipal officials, the E&S plan preparer, the PCSM plan preparer, and a representative from the (insert appropriate County) conservation district to an on-site preconstruction meeting.
2. Upon installation or stabilization of all perimeter sediment control BMPs and at least 3 days prior to proceeding with the bulk earth disturbance activities, the permittee or co-permittee shall provide notification to the Department or authorized conservation district.
3. At least 3 days prior to starting any earth disturbance activities, or expanding into an area previously unmarked, the Pennsylvania One Call System Inc. shall be notified at 1-800-242-1776 for the location of existing underground utilities.
4. All earth disturbance activities shall proceed in accordance with the sequence provided on the plan drawings. **Deviation from that sequence must be approved by the (insert appropriate County) conservation district or by the Department prior to implementation. Each step of the sequence shall be completed before proceeding to the next step, except where noted.**

The following is a suggested outline for a typical BMP installation sequence. It represents the order in which the most common BMPs would be installed for most sites. The actual construction sequence for a specific project may include items not mentioned here or even omit some that are shown, depending on site conditions and the nature of the project. In all cases, additional site-specific information would be required for the sequence to be considered complete.

#### **SUGGESTED OUTLINE FOR BMP SEQUENCING**

1. Field-mark limits of disturbance and environmentally sensitive areas (including steep slopes, riparian buffers, wetlands, springs, and floodways)
2. Rock Construction Entrance(s)
3. Access to Site/BMPs
  - a) Access Roads and their BMPs
  - b) Temporary/Permanent Stream Crossings
  - c) Roadway Drainage Structures
4. Surface Water Diversion
  - a) Diversion Channels and Berms
  - b) Stabilization of Channels and Berms
5. Installation of Sediment Barriers
6. Solids Separation BMPs
  - a) Sediment Basins
    - (1) Sediment Barriers
    - (2) Conveyance from Outlet Structures to Surface Water
    - (3) Principal Spillway and Energy Dissipater
    - (4) Earthwork to Construct Sediment Basin
    - (5) Emergency Spillway and Lining
    - (6) Stabilization of Basin and of Areas Disturbed to Construct Sediment Basin
  - b) Sediment Traps
    - (1) Conveyance from Outlet Structures to Surface Water
    - (2) Construct Sediment Trap
    - (3) Stabilization of Trap and of Areas Disturbed to Construct Sediment Trap
7. Collection of Site Runoff for Treatment

- a) Collector Channels, Waterbars, Broad-based dips, etc.
- b) Stabilization of Channels, Waterbars, Broad-based dips, etc.
- 8. Site Earthwork
  - a) Grubbing
  - b) Excavations with incremental stabilization
  - c) Fills with incremental stabilization
  - d) Construction of Buildings, Roadways and Other Structures
  - e) Site Utility Construction
- 9. Permanent Stabilization
  - a) Replacement of Topsoil (4 - 6 inches)
  - b) Permanent Seeding
    - (1) Soil Amendments
    - (2) Seed Application
    - (3) Mulch and/or blanketing
  - c) Crushed Aggregate Surfaces (Apply as soon as road or parking lot surfaces are graded)
  - d) Paved areas
- 10. Removal/Conversion of Temporary Sediment Pollution Controls
  - a) Permanent Vegetation Requirement
  - b) Interceptor Channels
  - c) Basins and Traps
  - d) Sediment Barriers
  - e) Temporary Diversion Channels
  - f) Stabilization of disturbed areas



## CHAPTER 3 - SITE ACCESS

This chapter addresses site access during actual construction of a proposed project. It should be noted that site access for site preparation work (e.g. surveying, exploration drilling, etc.) should follow the same general principals. When it becomes necessary to remove vegetative cover or cross surface waters to conduct a survey, or complete required exploration drilling and sampling, appropriate BMPs must be provided to protect the surface waters. BMPs not addressed in this chapter may be reviewed by the Department on a case-by-case basis and approved if they are found to be equal to, or better than, the following BMPs.

**ROCK CONSTRUCTION ENTRANCE - Sediment Removal Efficiency: LOW. This device is not an ABACT for special protection watersheds.** A rock construction entrance should be installed wherever it is anticipated that construction traffic will exit the project site onto any roadway, public or private. Access to the site should be limited to the stabilized construction entrance(s).



Lake County Stormwater Management Department, Ohio

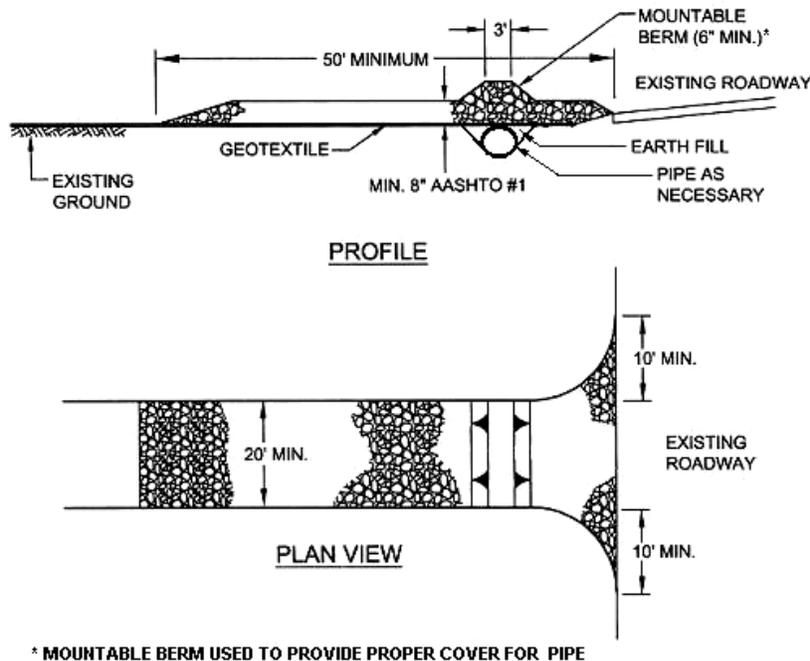
A geotextile underlayment should be placed over the existing ground prior to placing the stone. At a minimum, rock construction entrances should be constructed to the dimensions shown on Standard Construction Detail #3-1. Where site conditions warrant, it may be necessary to extend the length or width of the rock to ensure the effectiveness of the entrance. Wherever access to the site is across a roadside ditch, stream channel, natural drainage course, etc., a suitable means of conveying the flow past the entrance (e.g. a properly sized culvert pipe) should be provided. For such installations, a mountable berm is recommended to prevent crushing the pipe.

Rock construction entrances should be maintained to the specified dimensions and the capacity to remove sediment from the tires by adding rock when necessary. For some sites this could occur several times a day. A stockpile of rock material should be maintained on site for this purpose. It should be noted that occasionally the rock construction entrance can become too clogged and might have to be removed and replaced.

Sediment deposited on public roadways should be removed and returned to the construction site immediately. **Note: Washing the roadway or sweeping the deposits into roadway ditches, sewers, culverts, or other drainage courses is not acceptable.**

Rock construction entrances are not effective sediment removal devices for runoff coming off the roadway above the entrance. Surface runoff should be directed off the roadway by means of appropriate drainage devices described later in this chapter. Where these devices do not discharge to a suitable vegetative filter strip, an appropriately sized sediment trap should be provided. For locations not having sufficient room for a conventional sediment trap, consideration should be given to use of a compost sock sediment trap. Compost sock traps may also be used instead of conventional sediment traps at other points of discharge. Where used, care should be taken to provide continuous contact between the sock and the underlying soil in order to prevent undermining. It is also important to properly anchor the sock (Standard Construction Detail #3-1).

### STANDARD CONSTRUCTION DETAIL # 3-1 Rock Construction Entrance



Modified from Maryland DOE

**Remove topsoil prior to installation of rock construction entrance. Extend rock over full width of entrance.**

**Runoff shall be diverted from roadway to a suitable sediment removal BMP prior to entering rock construction entrance.**

**Mountable berm shall be installed wherever optional culvert pipe is used and proper pipe cover as specified by manufacturer is not otherwise provided. Pipe shall be sized appropriately for size of ditch being crossed.**

**MAINTENANCE:** Rock construction entrance thickness shall be constantly maintained to the specified dimensions by adding rock. A stockpile shall be maintained on site for this purpose. All sediment deposited on paved roadways shall be removed and returned to the construction site immediately. If excessive amounts of sediment are being deposited on roadway, extend length of rock construction entrance by 50 foot increments until condition is alleviated or install wash rack. Washing the roadway or sweeping the deposits into roadway ditches, sewers, culverts, or other drainage courses is not acceptable.

ROCK CONSTRUCTION ENTRANCE WITH WASH RACK - Sediment Removal Efficiency: HIGH. **This device is an ABACT for HQ and EV watersheds.** Rock construction entrances with wash racks should be considered wherever soil and/or traffic conditions require washing the construction vehicle wheels prior to exiting the site to avoid excessive tracking of mud onto a highway. Access to the site should be limited to the stabilized entrance(s). NOTE: Wash racks in construction entrances are for washing of tires only. Where it is necessary to wash an entire vehicle prior to leaving the site, this should be done at a site designed to prevent untreated nutrient-enriched wastewater or hazardous wastes from being discharged to surface or ground waters.



EPA

At a minimum, rock construction entrances with wash racks should be constructed to the length, width, and thickness dimensions shown on Standard Construction Detail #3-2. A metal wash rack (like the one illustrated above) is an acceptable alternative to the reinforced concrete one shown in the standard detail.

Approaches to the wash rack should be lined with AASHTO #1 at a minimum of 25' on both sides.

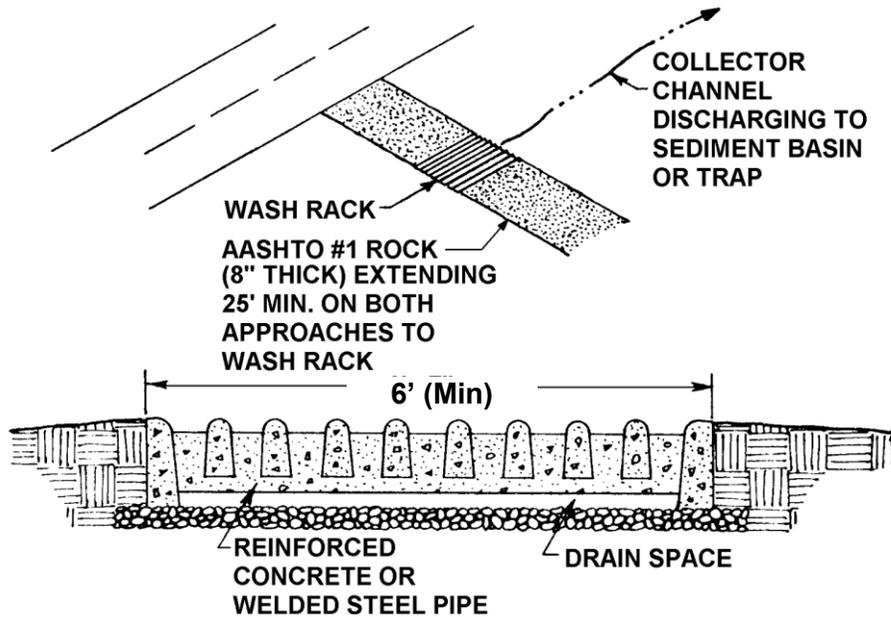
The wash rack should discharge to a sediment removal facility, such as a vegetated filter strip or into a channel leading to a sediment removal device (e.g. a sediment trap or sediment basin).

Rock construction entrances with wash racks should be maintained to the specified dimensions by adding rock when necessary at the end of each workday. A stockpile of rock material should be maintained on site for this purpose.

Sediment deposited on paved roadways should be removed and returned to the construction site. **NOTE: Washing the roadway or sweeping the deposits into roadway ditches, sewers, culverts, or other drainage courses is not acceptable.**

Damaged wash racks should be repaired as necessary to maintain their effectiveness.

**STANDARD CONSTRUCTION DETAIL # 3-2  
Rock Construction Entrance with Wash Rack**



Modified from Smith Cattleguard Company

**Wash rack shall be 20 feet (min.) wide or total width of access.**

**Wash rack shall be designed and constructed to accommodate anticipated construction vehicular traffic.**

**A water supply shall be made available to wash the wheels of all vehicles exiting the site.**

**MAINTENANCE:** Rock construction entrance thickness shall be constantly maintained to the specified dimensions by adding rock. A stockpile of rock material shall be maintained on site for this purpose. Drain space under wash rack shall be kept open at all times. Damage to the wash rack shall be repaired prior to further use of the rack. All sediment deposited on roadways shall be removed and returned to the construction site immediately. Washing the roadway or sweeping the deposits into roadway ditches, sewers, culverts, or other drainage courses is not acceptable.

## RUMBLE PAD

Pre-constructed rumble pads may be used instead of rock construction entrances provided they are installed according to manufacturer's recommendations and a sufficient number of pads are installed to provide for a minimum of four tire revolutions while on the pad. More pads may be needed depending on site conditions. Accumulated materials should be cleaned from the pads daily (more often if necessary) and disposed in the manner specified by the plan. Rumble pads are not ABACT.



All World Equipment

## WHEEL WASH

Manufactured wheel washes may be used as ABACT in special protection watersheds or where special traffic safety issues exist. All such wheel washes should be installed and operated according to the manufacturer's specifications. Waste water from the wheel washes should either be recycled or run through an approved sediment removal device prior to discharge to a surface water.



NW Equipment Sales

## TEMPORARY AND PERMANENT ACCESS ROADS

In order to construct perimeter BMPs such as basins, traps, channels, and even super silt fence, it is often necessary to construct temporary access roads. When temporary E&S BMPs are converted to PCSM BMPs, these access roads may become permanent. If not properly aligned, drained, and maintained, access roads can become significant sources of sediment pollution. Therefore, careful thought should be given to the location and construction of access roads. When considering the proper location for an access road, particular attention should be given to steep slopes, surface waters, rock outcrops, soil types, and other potential hazards.



Source Unknown

Once the most efficient point of ingress and egress has been determined, the next critical aspect to be considered is the grade. Ideally, road grades should be between 2 and 10 percent. Grades up to 20 percent are not recommended except where absolutely necessary and for short distances.

On long, continuous grades, runoff should be directed off the roadway by means of crowning, insloping, waterbars, broad-based dips, deflectors, or open-top culverts. All discharges should be to stable drainage courses, or to well-vegetated areas. Consideration should also be given to whether outlet protection is needed.

Access roads should be constructed above flood plains and avoid drainage courses wherever possible. Where it is not possible to avoid drainage courses, seeps, springs, or wet areas, proper drainage measures should be installed. Roadways paralleling surface waters should be located so that an adequate filter strip of undisturbed vegetation remains between the road and the stream. If this is not possible, a suitable sediment barrier should be installed. Appropriate Chapter 105 water obstruction and encroachment authorization must be obtained prior to construction in these areas.

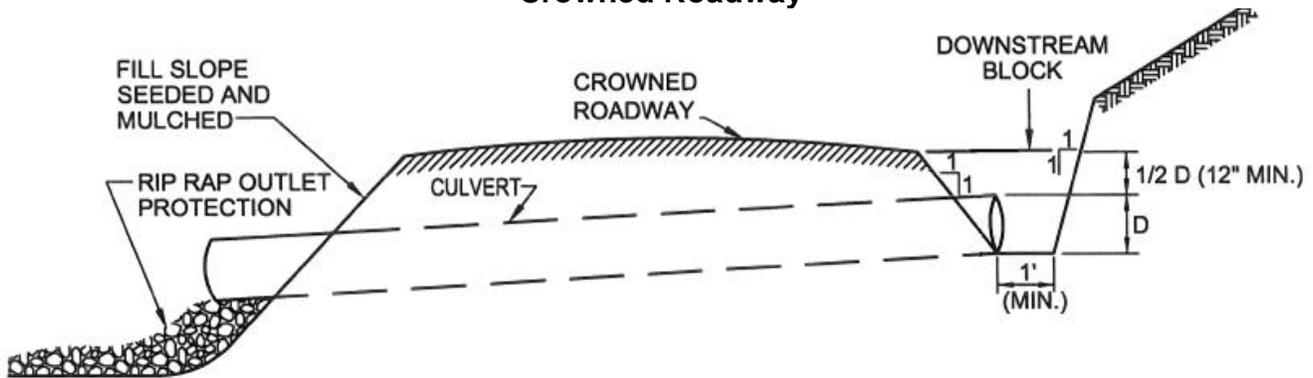
Wherever it is necessary to cross a watercourse, as defined bed and banks, a properly sized and stabilized temporary crossing must be provided. Ford type stream crossings are typically not acceptable for construction sites.

Cuts and fills should be minimized. Long and/or high cut/fill slopes are often difficult to stabilize. In soils with low shear strength, they also pose an increased potential for slope failures. Cuts deeper than

3 feet should be avoided wherever possible, and cut slopes not in competent bedrock should not be steeper than 2H:1V. Fill slopes should not be steeper than 2H:1V or exceed 5 feet in height wherever possible. All cut and fill slopes should be stabilized by seeding and mulching, blanketing, or other suitable method within 24 hours of reaching final grade. This will require the contractor to anticipate the date of completion and schedule ahead for seeding and mulching.

Road surfaces should be sloped for drainage. In flatter areas, crowning is the most efficient means of draining the roadway (Standard Construction Detail # 3-3). For hillside construction, insloping with adequately spaced cross drains is recommended (Standard Construction Detail # 3-4). Outsloping roads can be very dangerous. Where crowning and insloping are not sufficient to address drainage requirements, waterbars, broad-based dips, deflectors, or culverts may be needed. All discharges should be to stable drainage courses, or to well-vegetated areas. Consideration should also be given if outlet protection is needed.

### STANDARD CONSTRUCTION DETAIL # 3-3 Crowned Roadway



PA DEP

**Cut and fill slopes shall be stabilized immediately upon completion of roadway grading. These areas shall be blanketed wherever they are located within 50 feet of a surface water or within 100 feet of an HQ or EV surface water or where a suitable vegetative filter strip does not exist.**

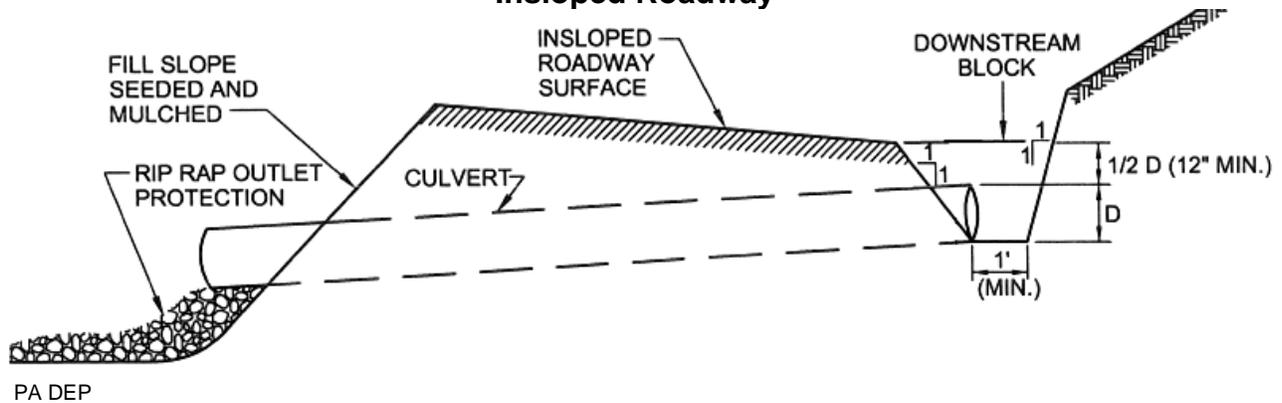
**A top dressing composed of hard, durable stone shall be provided for soils having low strength.**

**Roadside ditches shall be provided with adequate protective lining wherever runoff cannot sheet flow away from the roadway.**

**Adequately sized culverts or other suitable cross drains shall be provided at all seeps, springs, and drainage courses. Ditch relief culverts or turnouts shall be provided at the intervals indicated on Table 3.3 or Table 3.4 for roadside ditches. Riprap outlet protection to be sized according to anticipated discharge velocity.**

**Roadway shall be inspected weekly and after each runoff event. Damaged roadways, ditches, or cross drains shall be repaired immediately.**

## STANDARD CONSTRUCTION DETAIL # 3-4 Insloped Roadway



Cut and fill slopes shall be stabilized immediately upon completion of roadway grading. These areas shall be blanketed wherever they are located within 50 feet of a surface water or within 100 feet of an HQ or EV surface water or where a suitable vegetative filter strip does not exist.

A top dressing composed of hard, durable stone, shall be provided for soils having low strength.

Roadside ditches shall be provided with adequate protective lining.

Adequately sized culverts or other suitable cross drains shall be provided at all seeps, springs, and drainage courses. Ditch relief culverts shall be provided at the intervals indicated on Table 3.3 or Table 3.4. Riprap outlet protection to be sized according to anticipated discharge velocity.

Roadway shall be inspected weekly and after each runoff event. Damaged roadways, ditches, or cross drains shall be repaired immediately.



**WATERBAR - Sediment Removal Efficiency: VERY LOW. This device by itself is not an ABACT for special protection watersheds.** However, waterbars can be used to make ABACT such as vegetative filter strips work more effectively by reducing the volume of discharge to a filter strip at any one location.

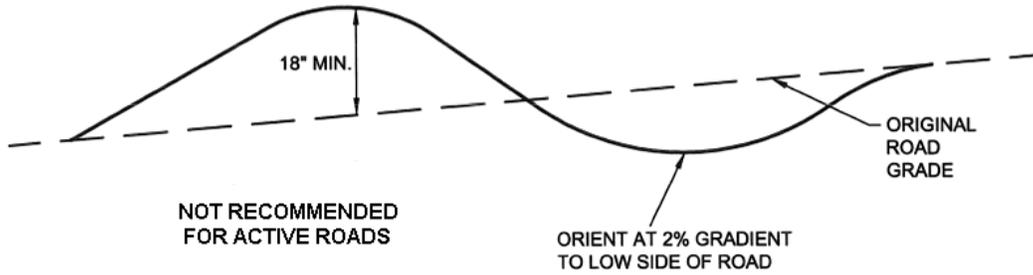
Waterbars are typically used to control stormwater runoff on retired access roads and skid trails as well as pipeline and utility line right-of-ways. They are not recommended for active access roads or skid trails due to the difficulty of moving equipment over them as well as the need for continual maintenance due to damage from traffic. Where waterbars are used on active access roads, it is often necessary to provide reinforcement of the berm with a log, steel pipe, etc. to maintain the integrity of the waterbar between maintenance operations. All such waterbars should be restored to original dimensions at the end of each work day. Waterbars are not appropriate for incised roadways, where there is no opportunity to discharge runoff to either side.



York CCD

Waterbars may be used to direct runoff to well-vegetated areas or sediment removal facilities (e.g. sediment traps or sediment basins). They should discharge to the downslope side of the access road, skid trail, or right-of-way so that runoff will flow away from, not back onto the roadway, skid trail, or right-of-way. A 2% maximum gradient is recommended to ensure proper discharge of water entering the waterbar. Steeper gradients should be avoided to prevent erosion of the waterbar. Wherever erodible soils are present, or where there is not a sufficient vegetative filter strip between the waterbar and a receiving surface water, the waterbar should be provided with a temporary protective liner. All waterbars should be vegetated. Obstructions, (e.g. straw bales, silt fence, rock filters, etc.) should not be placed in or across waterbars.

**STANDARD CONSTRUCTION DETAIL #3-5  
Waterbar**



Adapted from USDA Forest Service

**Waterbars shall discharge to a stable area.**

**Waterbars shall be inspected weekly (daily on active roads) and after each runoff event. Damaged or eroded waterbars shall be restored to original dimensions within 24 hours of inspection.**

**Maintenance of waterbars shall be provided until roadway, skidtrail, or right-of-way has achieved permanent stabilization.**

**Waterbars on retired roadways, skidtrails, and right-of-ways shall be left in place after permanent stabilization has been achieved.**

**TABLE 3.1 – Maximum Waterbar Spacing**

<b>PERCENT SLOPE</b>	<b>SPACING (FT)</b>
<5	250
5 - 15	150
15 - 30	100
> 30	50

Adapted from USDA Forest Service

**BROAD-BASED DIP - Sediment Removal Efficiency: VERY LOW. This device by itself is not an ABACT for special protection watersheds, but like a waterbar can be used to make an ABACT BMP work more effectively.** Broad-based dips may be used to direct runoff from active access roads to well-vegetated areas or sediment removal BMPs (e.g. sediment traps or sediment basins). Broad-based dips, unlike waterbars, are easily traversed by most construction equipment and typically require less maintenance to ensure their integrity. Due to the nature of broad-based dips, they should not be constructed on roads with grades exceeding 10%. Where access roads exceed 10% gradients, insloping or other deflection devices should be used to control runoff.



PA DEP

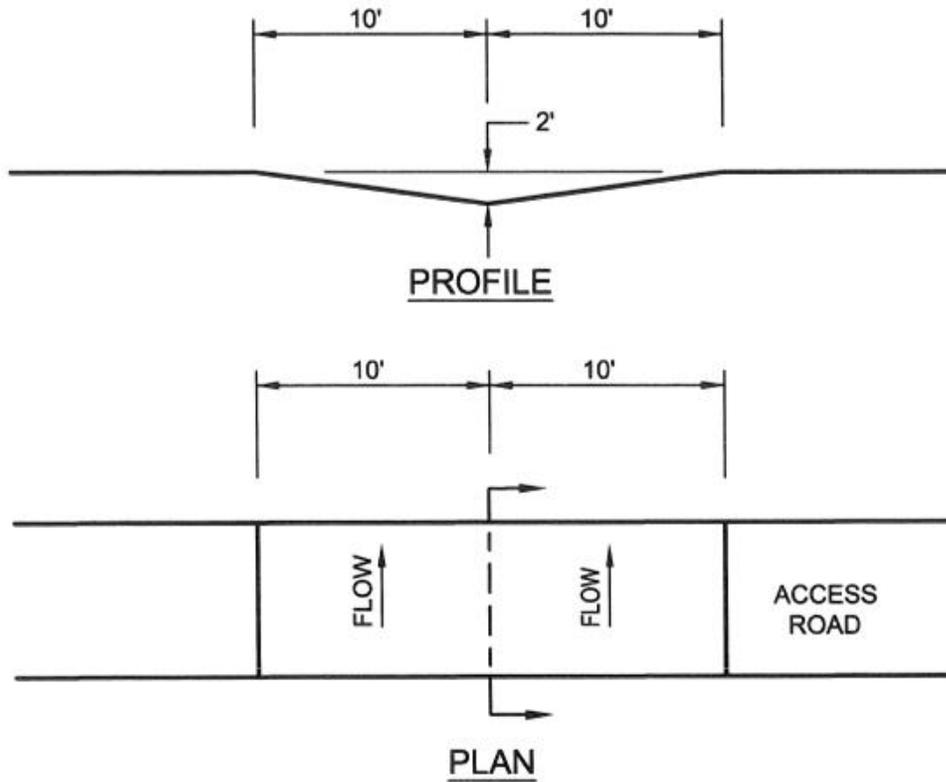
Discharges should be to the downslope side of access roads with a maximum gradient of 3% in the dip. For access roads with grades up to 5%, Standard Construction Detail # 3-6 should be used. Roadways with steeper grades should use Standard Construction Detail # 3-7.

**TABLE 3.2 – Maximum Spacing of Broad-based Dips, Open-top Culverts and Deflectors**

Road Grade (Percent)	Spacing Between Dips, Culverts, or Deflectors (feet)
<2	300
3	235
4	200
5	180
6	165
7	155
8	150
9	145
10	140

USDA Forest Service

**STANDARD CONSTRUCTION DETAIL # 3-6  
Broad-based Dip for Low Gradient ( $\leq 5\%$ ) Roadways**



Maine DEP

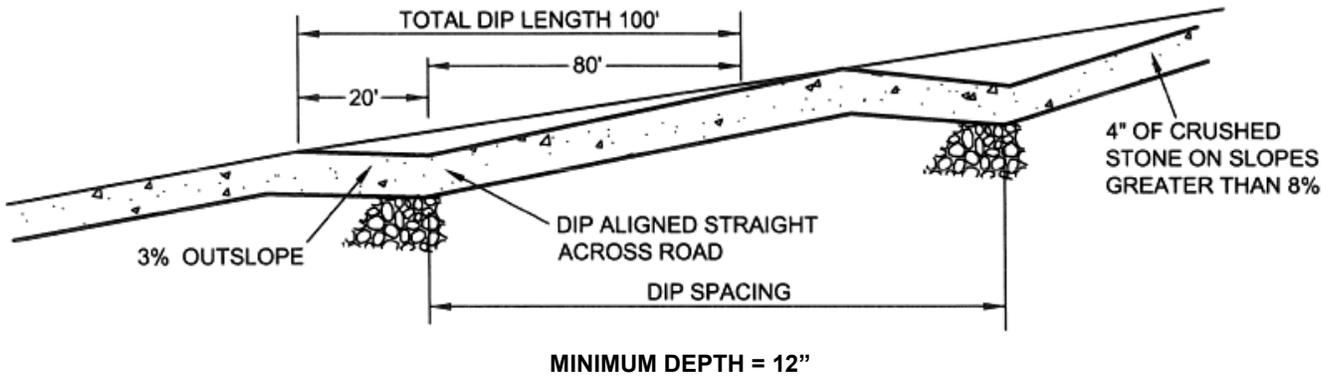
**Broad-based dips shall be constructed to the dimensions shown and at the locations shown on the plan drawings.**

**Dips shall be oriented so as to discharge to the low side of the roadway.**

**Dips shall be inspected daily. Damaged or non-functioning dips shall be repaired by the end of the workday.**

**Maximum spacing of broad-based dips shall be as shown in Table 3.2**

**STANDARD CONSTRUCTION DETAIL # 3-7**  
**Broad-based Dip for High Gradient (5% - 10%) Roadways**



USDA Forest Service

**Broad-based dips shall be constructed to the dimensions shown and at the locations shown on the plan drawings.**

**Dips shall be oriented so as to discharge to the low side of the roadway.**

**Dips shall be inspected daily. Damaged or non-functioning dips shall be repaired by the end of the workday.**

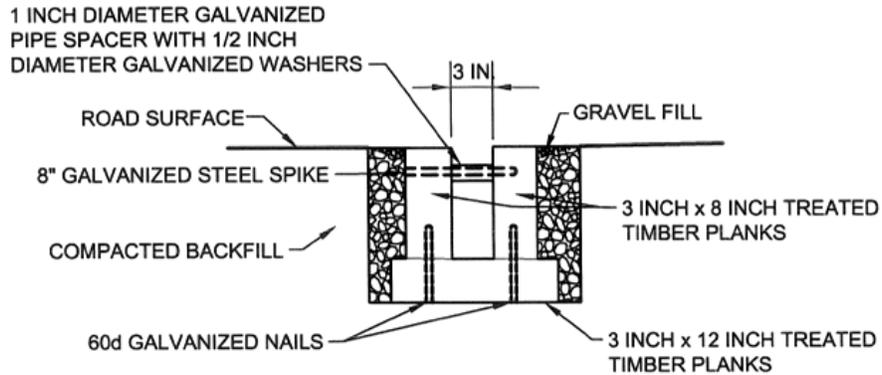
**Maximum spacing of broad-based dips shall be as shown in Table 3.2.**

**OPEN-TOP CULVERTS - Sediment Removal Efficiency: VERY LOW. This device is not an ABACT for special protection watersheds, but may be used to make other BMPs that are ABACT work more effectively.** Open-top culverts may be used to intercept runoff from access or haul roads and divert it to well-vegetated (erosion resistant) areas or sediment removal facilities. Such culverts are typically more easily traversed than either waterbars or broad-based dips, but can require more maintenance if being crossed by heavy equipment or exposed to sediment-laden runoff. Open-top culverts are not acceptable for stream crossings and should not be used instead of pipe culverts. Spacing should be according to Table 3.2.

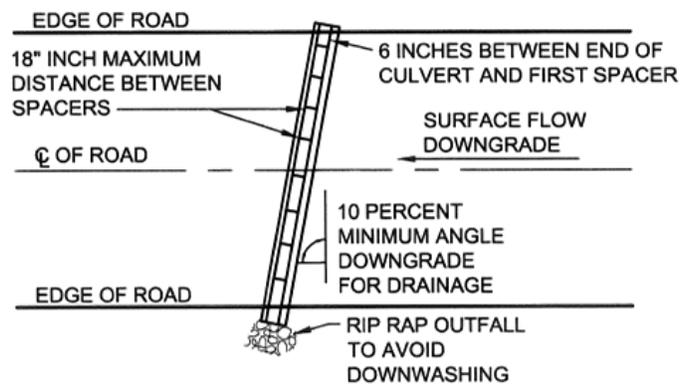


Source Unknown

## STANDARD CONSTRUCTION DETAIL #3-8 Open-top Culvert



TYPICAL CROSS-SECTION



TYPICAL PLAN VIEW

USDA Forest Service

**Culverts shall be inspected weekly and after runoff events.**

**Damaged or non-functioning culverts shall be repaired by the end of the workday.**

**Accumulated sediment shall be removed within 24 hours of inspection.**

**Maximum spacing of open-top culverts shall be as shown in Table 3.2.**

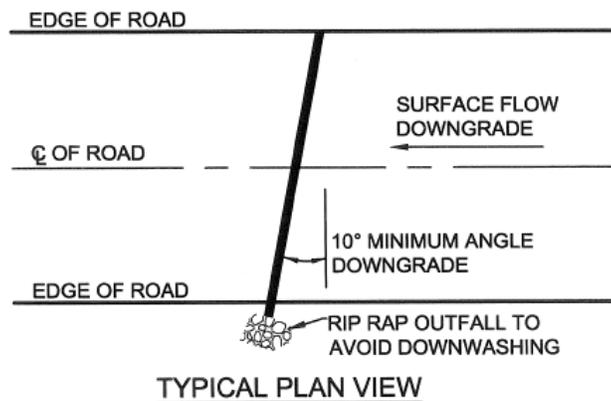
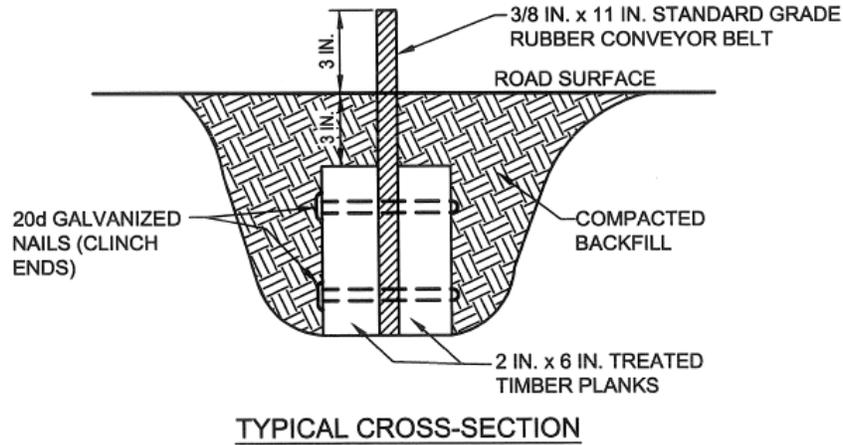
WATER DEFLECTOR - **Sediment Removal Efficiency: VERY LOW. This device is not an ABACT for special protection watersheds, but may be used to make other BMPs that are ABACT work more effectively.** Deflectors may be used instead of open-top culverts to direct runoff from an access road to a well-vegetated area or sediment removal facility. A deflector is typically constructed from rubber belting ranging from 5/16" to 1/2" thick held between two 2" X 6" wooden planks. This method of directing runoff from an access road works best on low traffic roads. Deflectors can be used on roads with grades exceeding 10%.



USDA Forest Service



## STANDARD CONSTRUCTION DETAIL #3-9 Water Deflector



USDA Forest Service

**Deflector shall be inspected weekly and after each runoff event.**

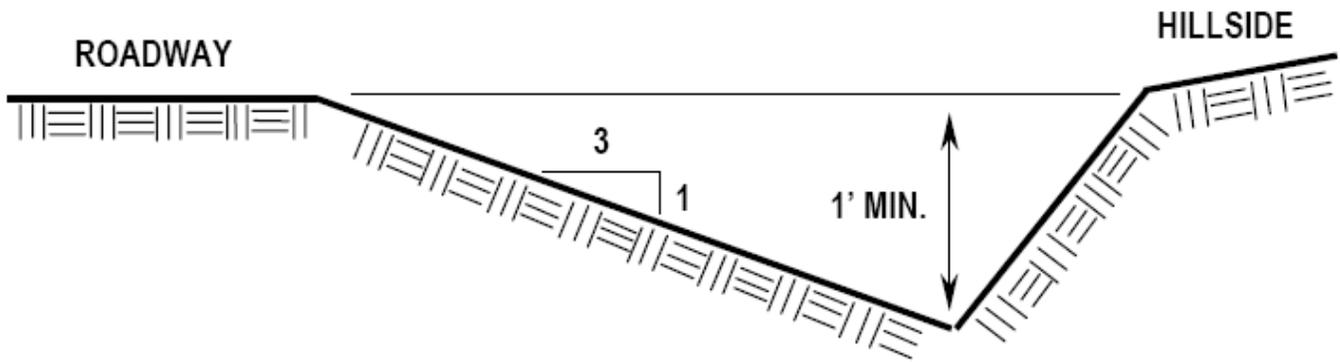
**Accumulated sediment shall be removed from deflector within 24 hours of inspection.**

**Belt shall be replaced when worn and no longer effective.**

**Maximum spacing of deflectors shall be as shown in Table 3.2.**

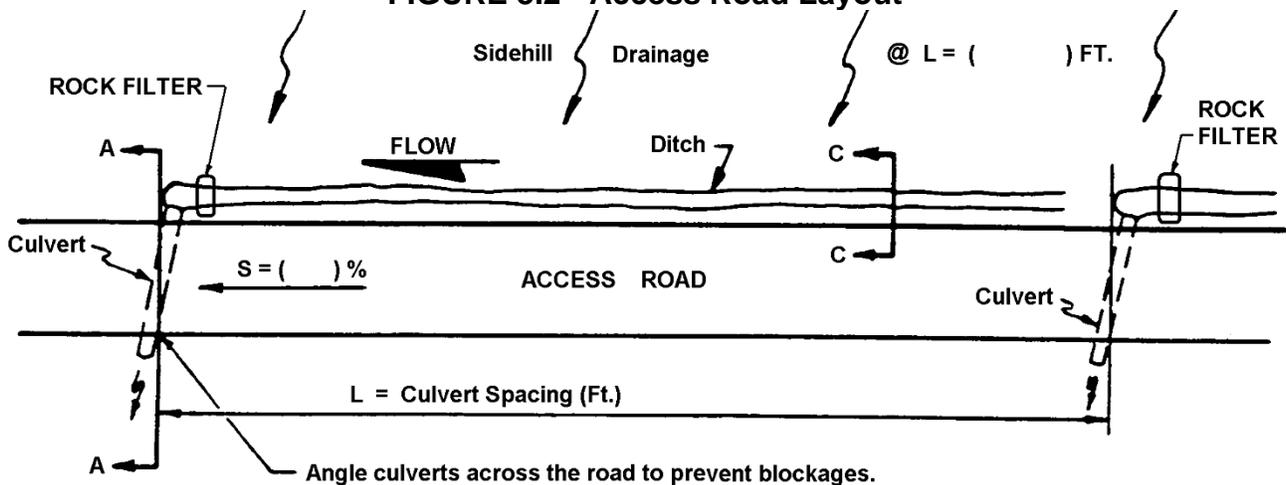
**ROADSIDE DITCH - Sediment Removal Efficiency: VERY LOW.** This device is not an ABACT for special protection watersheds, but may be used to make other BMPs that are ABACT work more effectively. In most cases, the ditches paralleling temporary access roads and haul roads need not be lined if sufficient ditch relief culverts are provided, erosion resistant soils are present, and flow velocities are less than 2 feet per second (fps). However, protective liners are required for roadside ditches discharging to special protection waters, where discharging directly to surface waters, or where necessary to prevent the erosion of the channel itself. A typical cross-section for a roadside ditch is shown in Figure 3.1.

**FIGURE 3.1 - Typical Roadside Ditch Section**



USDA Forest Service

**FIGURE 3.2 - Access Road Layout**



USDA Forest Service

Sizing and spacing of ditch relief culverts should be according to Table 3.3. Rock filters are not required where roadway surface is stabilized, ditches are provided with protective liners, and cut banks are stabilized. Suitable outlet protection should be provided at each culvert outfall.

**DITCH RELIEF CULVERT (Cross Drains) - Sediment Removal Efficiency: VERY LOW. This device is not an ABACT for special protection watersheds, but may be used to make other BMPs which are ABACTs work more effectively.** Ditch relief culverts minimize the potential for erosion of roadside ditches as well as flooding of the roadway by reducing the volume of flow being conveyed by the ditch. In addition to providing a culvert wherever concentrated upslope drainage is encountered, it is important to provide additional culverts at intervals along the roadway where runoff is being conveyed by a ditch (Figure 3.2) (Standard Construction Detail #3-10).



Source Unknown

Ditch relief culverts should be placed with a slope of 2 to 4 percent to help keep the culvert clean and ensure water flow. Sizing and spacing of culverts should be according to Table 3.3 for temporary culverts and Table 3.4 for permanent culverts.

**TABLE 3.3 - Sizing and Spacing of Ditch Relief Culverts for Temporary Access Roads**

Road Grade (%)	Culvert Spacing* (ft)	Length of Upslope Drainage (ft)				
		< 300	300 - 400	400 - 500	500 - 600	>600
		Minimum Culvert Size (in)				
2	300	12	15	15	15	18
3	235	12	15	15	15	18
4	200	12	15	15	15	18
5	180	12	12	15	15	15
6	165	12	12	12	15	15
7	155	12	12	12	12	15
8	150	12	12	12	12	15
9	145	12	12	12	12	15
10	140	12	12	12	12	15
12	135	12	12	12	12	15

Adapted from Maryland DOE

\*Culvert spacing may be adjusted slightly to take advantage of natural drainage courses.

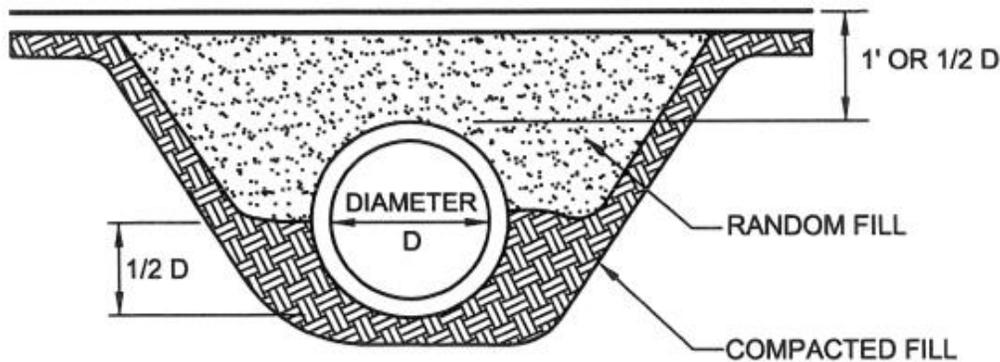
**TABLE 3.4 - Recommended Maximum Spacing of Ditch Relief Culverts (18" dia. CMP)  
For Permanent Access Roads**

Road Grade Percent	Soil Type in Ditch				
	Gravels, Sandy Gravels, Aggregate Surfacing	Silty Gravels, Clayey Gravels	Plastic and Nonplastic Inorganic Clays	Inorganic Silts, Silty or Clayey Sands	Sands, Silty Sands, and Gravelly Sands
	Culvert Spacing Feet*				
2	390	315	245	170	95
4	335	275	210	145	85
6	285	230	180	125	75
8	240	195	150	105	65
10	200	160	125	90	55
12	160	130	105	75	45
14	135	110	85	60	35

Adapted from USDA Forest Service

\*Culvert spacing may be adjusted slightly to take advantage of natural drainage courses.

**STANDARD CONSTRUCTION DETAIL #3-10  
Ditch Relief Culvert**



USDA Forest Service

Minimum diameter for any culvert is 12"; otherwise culvert shall be sized for anticipated peak flow. Place culvert so bottom is at same level as bottom of ditch or adjoining slope. Culverts shall be placed with a slope of 2 to 4%. Lower end shall be at least 2" below upper end.

Extend culvert 12" beyond base of road fill on both sides. Firmly pack fill around culvert, especially the bottom half.

Provide suitable outlet protection\* and, where appropriate, inlet protection.

Inspect culvert weekly: remove any flow obstructions and make necessary repairs immediately.

NOTE: This detail may be used for ditch relief culverts and for crossings of roadside ditches. It is not appropriate for stream crossings.

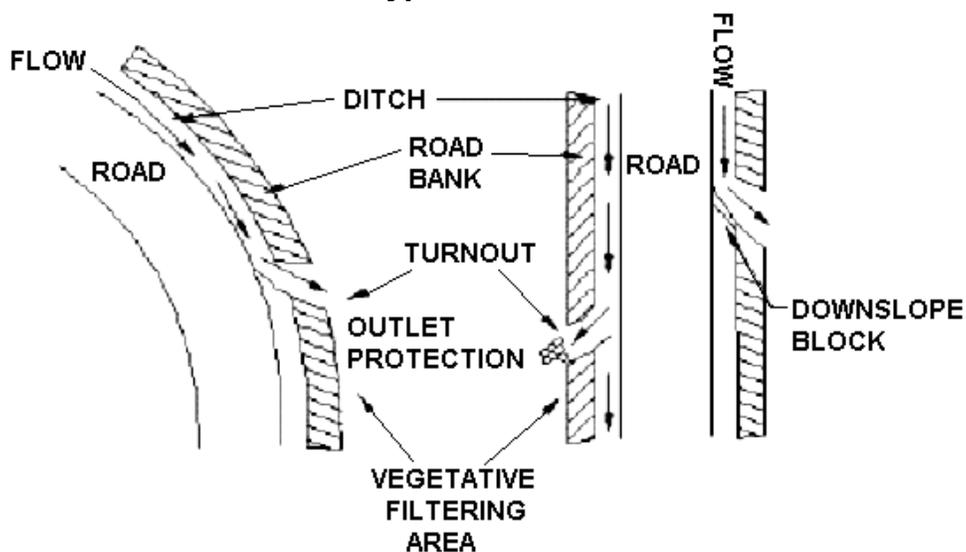
\* For steep slope ( $\geq 2H:1V$ ) outfalls, a minimum 20 foot long R- 5 apron is recommended for temporary access roads where the recommended culvert spacing is used. For permanent access roads, a minimum R-6 rock size is recommended.

**TURNOUT - Sediment Removal Efficiency: VERY LOW.** This device is not an ABACT for special protection watersheds, but may be used to make other BMPs which are ABACT work more effectively. Channels that drain water away from roads or roadside ditches into well-vegetated areas are known as turnouts. Turnouts (see Figure 3.3) are typically located along crowned roadways where runoff cannot sheet flow off the roadway. Like ditch relief culverts, the purpose of turnouts is to minimize the volume of water in a roadside ditch. Turnouts should be located so as to take advantage of natural drainage courses or buffer areas wherever possible. **An excavated sump at the end of the turnout can be effectively used to pond and settle out sediment prior to discharging to a vegetated buffer.** Where a suitable vegetative filter strip is not available, a compost filter sock, rock filter or other sediment removal BMP should be installed at the outlet of the turnout.



Source Unknown

**FIGURE 3.3  
Typical Turnout**



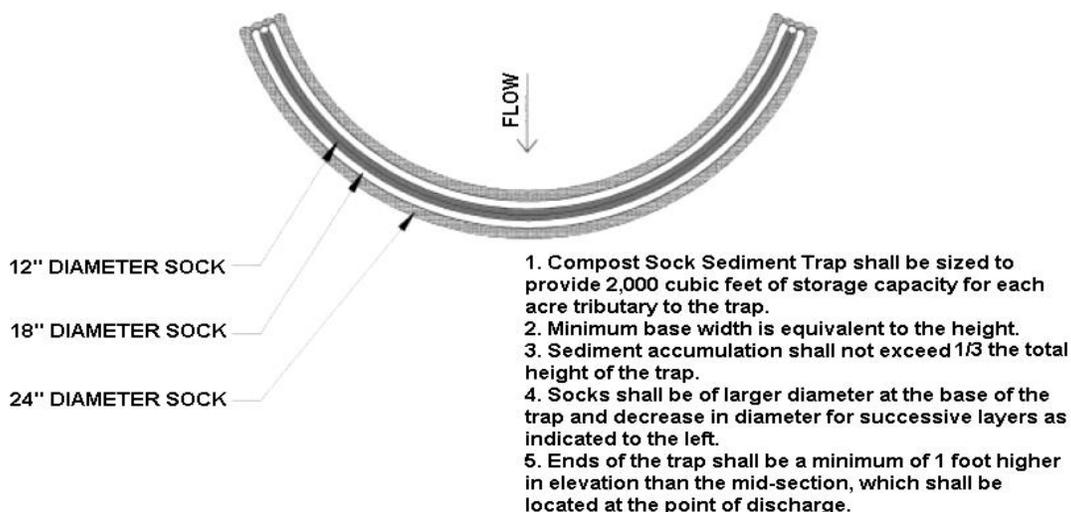
Indiana CCD

**COMPOST SOCK SEDIMENT TRAP - Sediment Removal Efficiency: HIGH. This device is an ABACT for HQ and EV watersheds.** In many locations, there is little or no opportunity to direct runoff from an access road into a well-vegetated area. This may occur at entrances or where surface waters are in relatively close proximity to the access road. At such locations it may still be possible to treat the runoff by means of a compost sock sediment trap. These structures can be installed, used and later removed with relatively little disturbance to the area. In fact, the compost within the sock can be used during cleanup as a vegetative growth medium. Runoff may be directed into the trap using any of the devices described above. Compost sock sediment traps are addressed in this chapter to emphasize their usefulness in controlling runoff from access roads. However, these devices may be used at some other locations where a temporary sediment trap is appropriate. The trap should be constructed according to Standard Construction Detail # 3-11. Sock material should meet the minimum standards provided in Table 4.1. Installation of an excavated sump immediately above the socks may increase trap efficiency where soil conditions permit their construction.

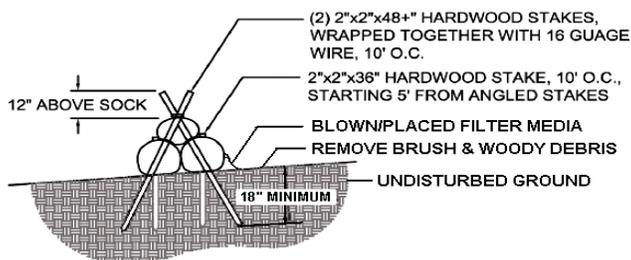


Filtrexx

## STANDARD CONSTRUCTION DETAIL #3-11 Compost Sock Sediment Trap



### PLAN VIEW



Adapted from Filtrexx

### STAKING DETAIL

Sock material shall meet the standards of Table 4.1. Compost shall meet the standards of Table 4.2.

Compost sock sediment traps shall not exceed three socks in height and shall be stacked in pyramidal form as shown above. Minimum trap height is one 24" diameter sock. Additional storage may be provided by means of an excavated sump 12" deep extending 1 to 3 feet upslope of the socks along the lower side of the trap.

Compost sock sediment traps shall provide 2,000 cubic feet storage capacity with 12" freeboard for each tributary drainage acre. (See manufacturer for anticipated settlement.)

The maximum tributary drainage area is 5.0 acres. Since compost socks are "flow-through," no spillway is required.

Compost sock sediment traps shall be inspected weekly and after each runoff event. Sediment shall be removed when it reaches 1/3 the height of the socks.

Photodegradable and biodegradable socks shall not be used for more than 1 year.

## TEMPORARY STREAM AND WETLAND CROSSINGS

### **STREAM CROSSING**

Because of the potential for stream degradation, flooding, and safety hazards, stream crossings should be avoided wherever possible. Alternate routes to work areas should be considered before planning the installation of a temporary stream crossing. Temporary stream crossings must be provided wherever construction equipment (including clearing and grubbing equipment) must cross an existing stream channel (water course with a defined bed and bank). Wherever such crossings are installed, the appropriate Chapter 105 permits must be obtained from the Department or its designee. Designs must adhere to the conditions of those permits.



Source Unknown

### **DESIGN CRITERIA**

1. All conditions listed on the General Permit-8 (GP-8) application must be met.
2. Ford type crossings should not be used by construction equipment. They should be used only where normal flow is shallow or intermittent across a wide channel and crossings are anticipated to be infrequent. Wherever possible, they should be located where a rocky stream bottom exists so as to minimize damage to the channel during crossings. Approaches should be stabilized with AASHTO #1. Fords are not authorized by general permits in special protection watersheds.



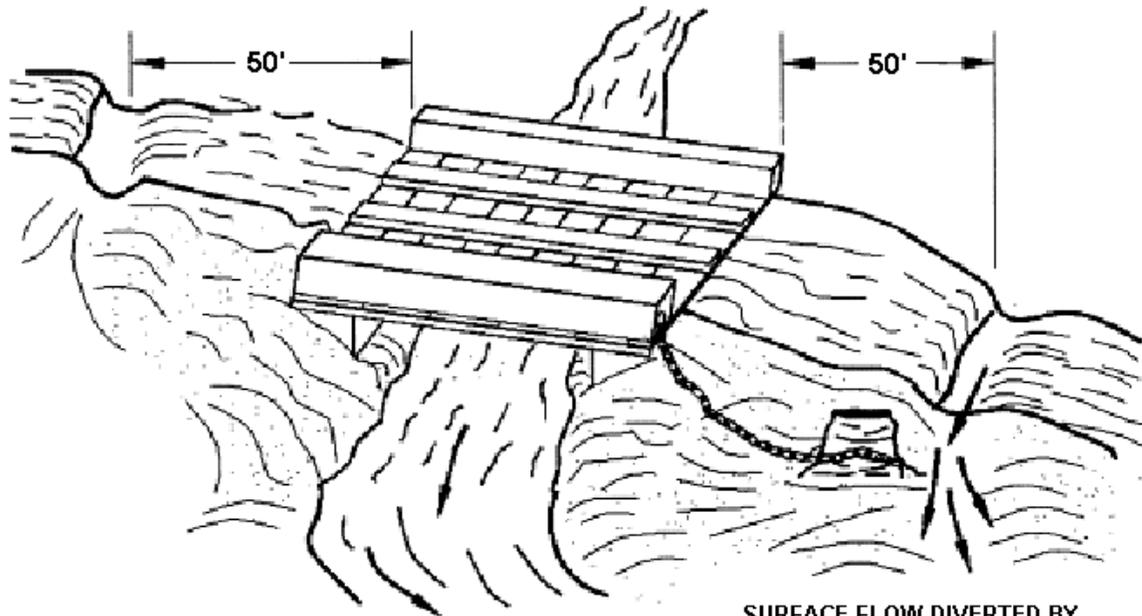
3. Temporary bridges should be installed as shown in Figure 3.4 and GP-8.
4. Culvert pipes must be installed according to GP-8 standards.
5. For crossings that will be in place for one year or less from the date of issuance (Chapter 105 temporary stream crossing permit), the pipe should be sized to handle flow under normal flow conditions. Normal flow refers to the flow conditions that exist in a given stream channel other than in response to storm or drought events. A common rule of thumb is to use a pipe or pipes with a diameter approximately twice the normal flow depth.
6. A series of pipes from stream bank to stream bank may be used where necessary.
7. The minimum pipe diameter is 12 inches.
8. Wherever multiple pipes are used, the minimum distance between pipes shall conform to Table 3.5.

**TABLE 3.5 - Minimum Distance Between Culvert Pipes**

<b>PIPE DIAMETER (D)</b>	<b>MINIMUM DISTANCE (F)</b>
12" to 24"	12"
24" to 72"	½ Diameter (D)
72" to 120"	36"
<b>PIPE ARCH SIZE (IN.)</b>	<b>MINIMUM DISTANCE (FF)</b>
18 x 11 to 25 x 16	12"
25 x 16 to 72 x 44	1/3 Span of Pipe Arch
Above 72 x 44	30"

8. Only clean rock fill may be used. The rock must be sized according to the anticipated flow conditions. The rock size used shall conform to Chapter 105 General Permit requirements. The rock fill should be extended a minimum of 50' from top of bank on each side of the crossing. The fill should be depressed a minimum of 6" over the channel to allow for overflow. The maximum depth of fill over the culvert is the minimum the manufacturer requires.
9. Suitable outlet protection should be provided where necessary to prevent scour at the pipe outlet. Wherever soft channel bed conditions exist, riprap protection should also be provided at the culvert entrance.

**FIGURE 3.4  
Temporary Bridge Stream Crossing**

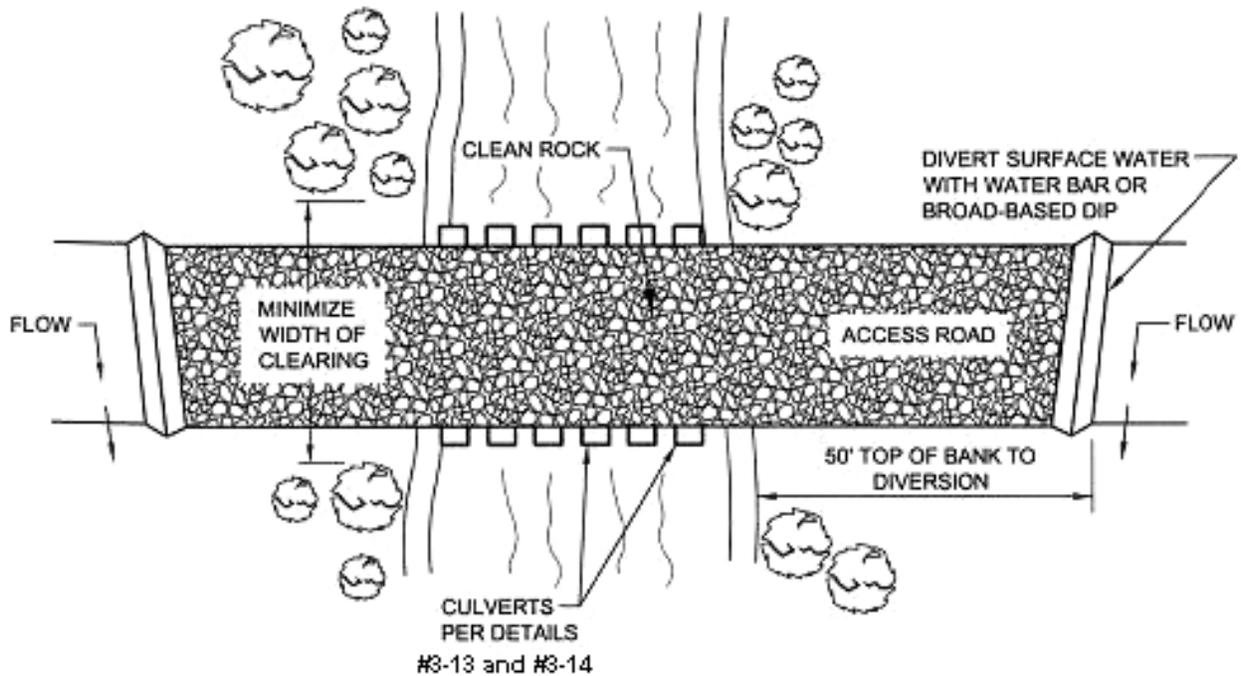


SURFACE FLOW DIVERTED BY WATERBAR OR BROAD-BASED DIP

Adapted from Maryland DOE

**Waterbars and broad-based dips shall discharge to sediment removal facilities.**

**STANDARD CONSTRUCTION DETAIL # 3-12  
Temporary Stream Crossing - Plan View**

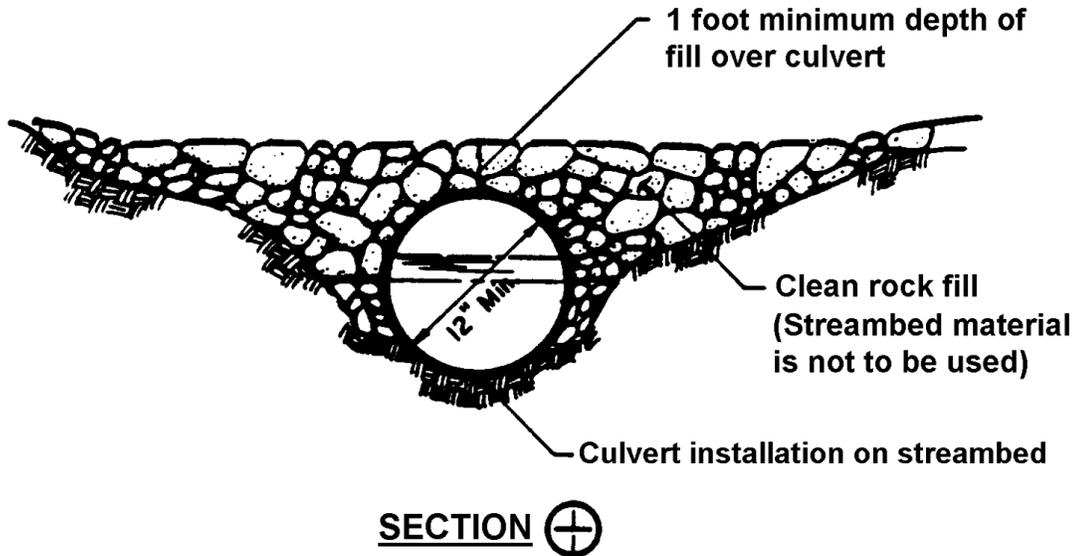


Adapted from Ohio EPA

**Waterbars and broad-based dips shall discharge to sediment removal facility.  
Clean rock shall conform to Chapter 105 permitting requirements.**

**Follow permit conditions regarding removal of crossing.**

**STANDARD CONSTRUCTION DETAIL # 3-13  
Temporary Stream Crossing**



PA DEP

Provide 50' stabilized access to crossing on both sides of stream channel (see Standard Construction Detail #3-12).

Pipes shall extend beyond the toe of the roadway.

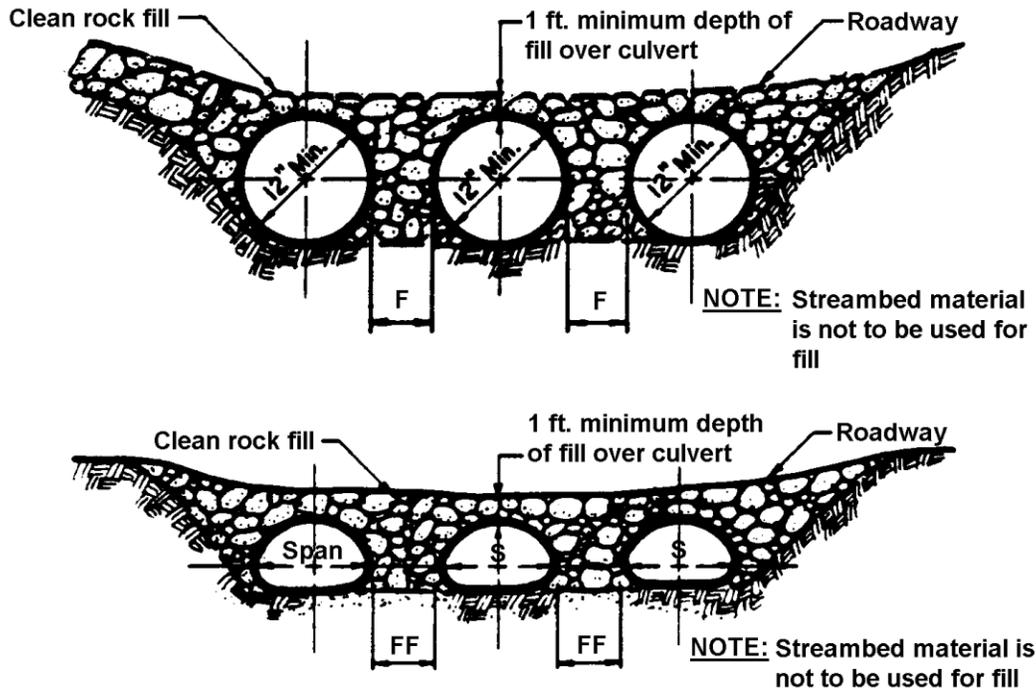
Runoff from the roadway shall be diverted off the roadway and into a sediment removal BMP before it reaches the rock approach to the crossing.

**MAINTENANCE**

1. Temporary stream crossings shall be inspected on a daily basis.
2. Damaged crossings shall be repaired within 24 hours of the inspection and before any subsequent use.
3. Sediment deposits on the crossing or its approaches shall be removed within 24 hours of the inspection

As soon as the temporary crossing is no longer needed, it shall be removed. All materials shall be disposed of properly and disturbed areas stabilized.

## STANDARD CONSTRUCTION DETAIL # 3-14 Temporary Stream Crossing - Multiple Pipes



### SECTIONS

PA DEP

Multiple pipes and multiple span bridges and culverts which may tend to collect debris, contribute to the formation of ice jams and increase head losses shall be avoided to the maximum extent practicable. Crossings of less than 15 feet shall be by one span, except where conditions make it impractical to affect the crossing without multiple spans (Section 105.162).

Provide 50' stabilized access to crossing on both sides of stream channel (Standard Construction Detail #3-12).

Pipes shall extend beyond the toe of the roadway.

Runoff from the roadway shall be diverted off the roadway and into a sediment removal BMP before it reaches the rock approach to the crossing.

### MAINTENANCE

1. Temporary stream crossings shall be inspected on a daily basis.
2. Damaged crossings shall be repaired within 24 hours of the inspection and before any subsequent use.
3. Sediment deposits on the crossing or its approaches shall be removed within 24 hours of the inspection

As soon as the temporary crossing is no longer needed, it shall be removed. All materials shall be disposed of properly and disturbed areas stabilized.

## WETLAND CROSSING

Wetland crossings must be avoided wherever possible. Where that is not possible, the location of the crossing and its orientation must be selected so as to have the least possible impact upon the wetland.

All wetland crossings must conform to Chapter 105 permitting requirements.

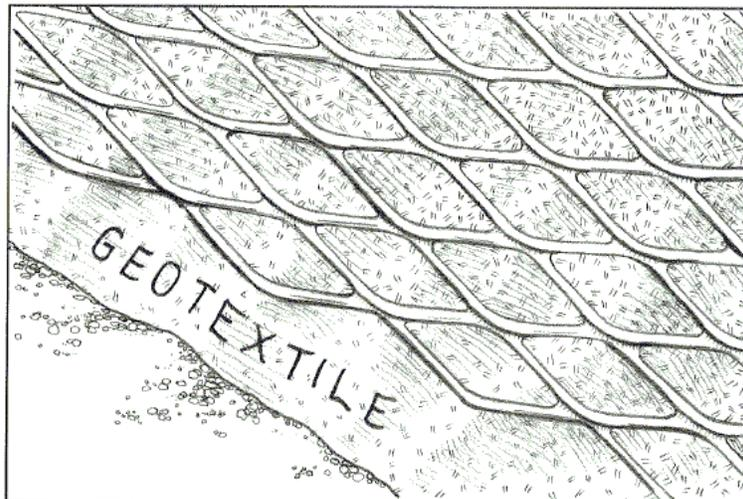
Temporary crossings should be constructed from materials that can be placed with a minimum of disturbance to the soil surface and completely removed when no longer needed. Some examples of stabilized crossing methods are illustrated in Figures 3.5 through 3.7 below.

**FIGURE 3.5**  
**Typical Tire Mat Wetland Crossing**

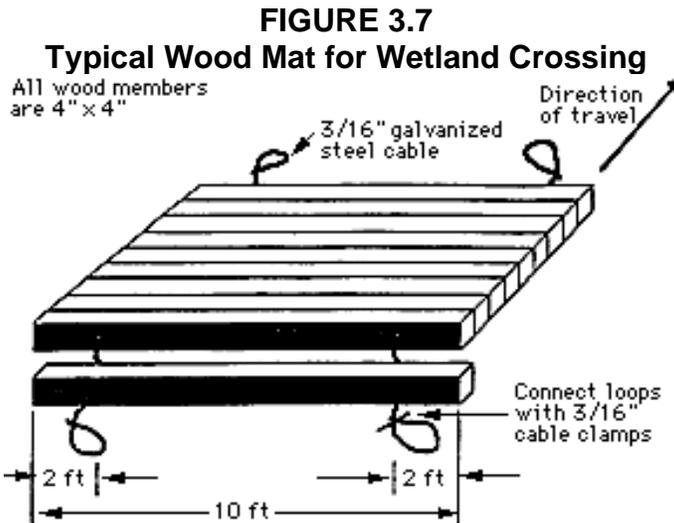


University of Minnesota FS 07013

**FIGURE 3.6**  
**Typical Expanded Metal Grating Wetland Crossing**



University of Minnesota FS 07011



University of Minnesota FS 07009

**A geotextile underlayment shall be used under the wood mat.**

### EARTHWORK WITHIN STREAM CHANNELS

**NOTE: Wherever the structures described in this section are installed, the appropriate Chapter 105 permits must be obtained from the Department. Designs must adhere to the conditions of those permits.**

Whenever possible, work should be scheduled for low flow seasons. Base flows for minor stream channels are to be diverted past the work area. For major stream channels (normal flow width > 10 feet) base flow shall be diverted wherever possible. All such bypasses must be completed and stabilized prior to diverting flow. Where diversion is not possible or where it can be shown that the potential environmental damage would be greater with diverted flow, this requirement may be waived. In either case, the duration of the disturbance must be minimized. All disturbed areas within the channel must be stabilized prior to returning base flow to the portion of the channel affected by the earthwork (Chapter 15).

Any in-channel excavations should be done from top of bank wherever possible unless this would require removal of mature trees to access the channel. Where it is not possible to work from top of bank, a temporary crossing or causeway (Figure 3.8) may be used to provide a working pad for any equipment within the channel. Upon completion, the crossing or causeway must be removed and all channel entrances restored, as much as possible, to pre-construction configurations, and stabilized. If it can be shown that there would be less disturbance to the channel by not using work pads (e.g. certain stream restorations), work within a live stream channel may be approved by the Department on a case-by-case basis.

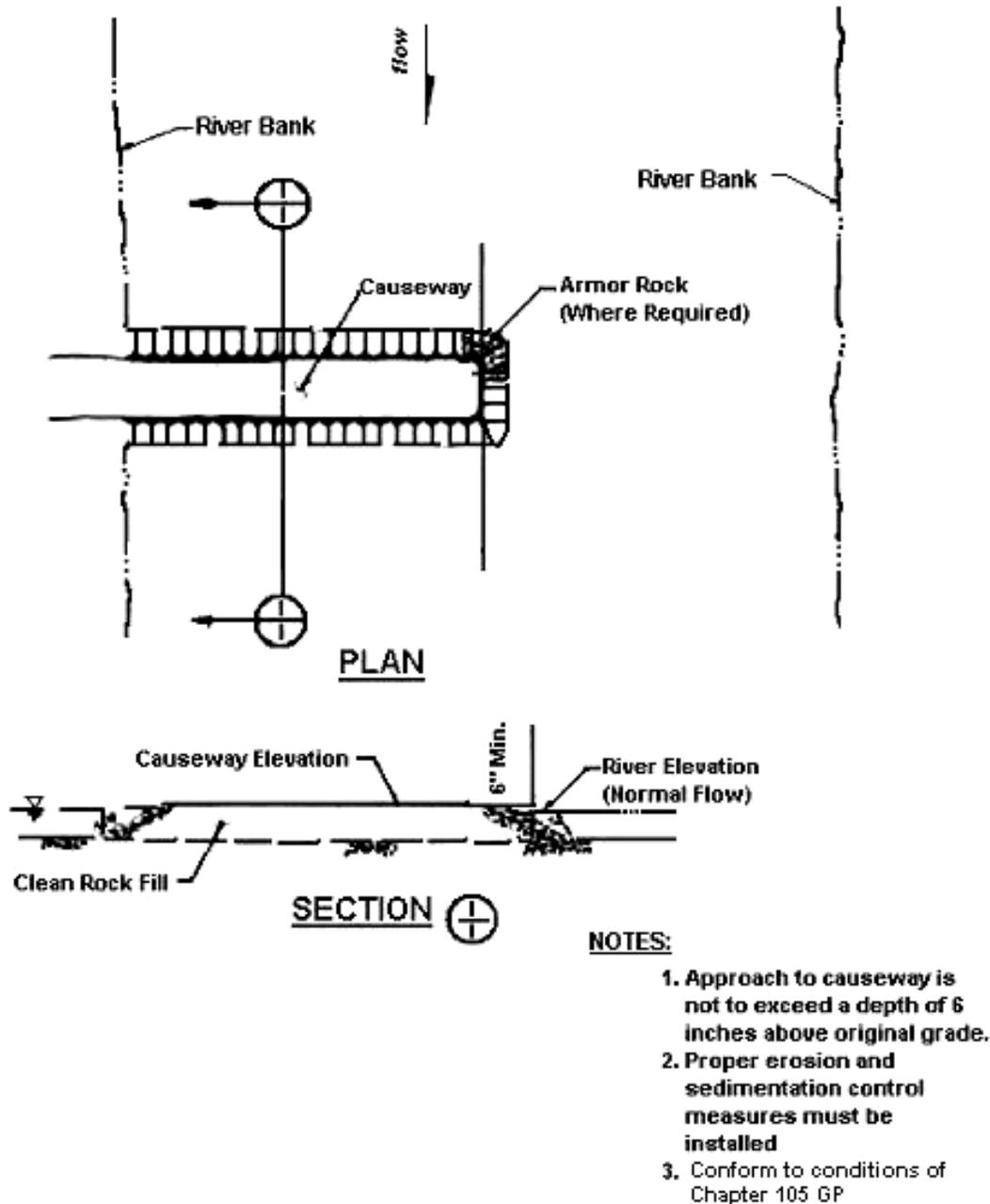
Except for pipeline & utility line projects (Chapter 13), all excavated channel materials that subsequently will be used as backfill are to be placed in a temporary stockpile located outside the channel floodway. A sediment barrier must be installed between the storage pile and the stream channel.

All excavated materials that will not be used on site shall be immediately removed to a disposal site having an approved E&S plan.

Any water pumped from excavated areas must be filtered prior to discharging into surface waters.

Suitable protection must be provided for the stream channel from any disturbed areas that have not yet achieved stabilization.

**FIGURE 3.8  
TYPICAL CAUSEWAY**



Adapted from PA DEP GP-8

Wherever a temporary bypass channel is used, it should conform to Figure 3.9. At a minimum, a geotextile protective lining should be provided for temporary bypass channels.

A temporary bypass channel should be designed to pass normal base flows if the crossing will be completed in one to three days, otherwise the channel should be designed for bank-full flow (original channel). All such channels should be constructed from the downstream end upward.

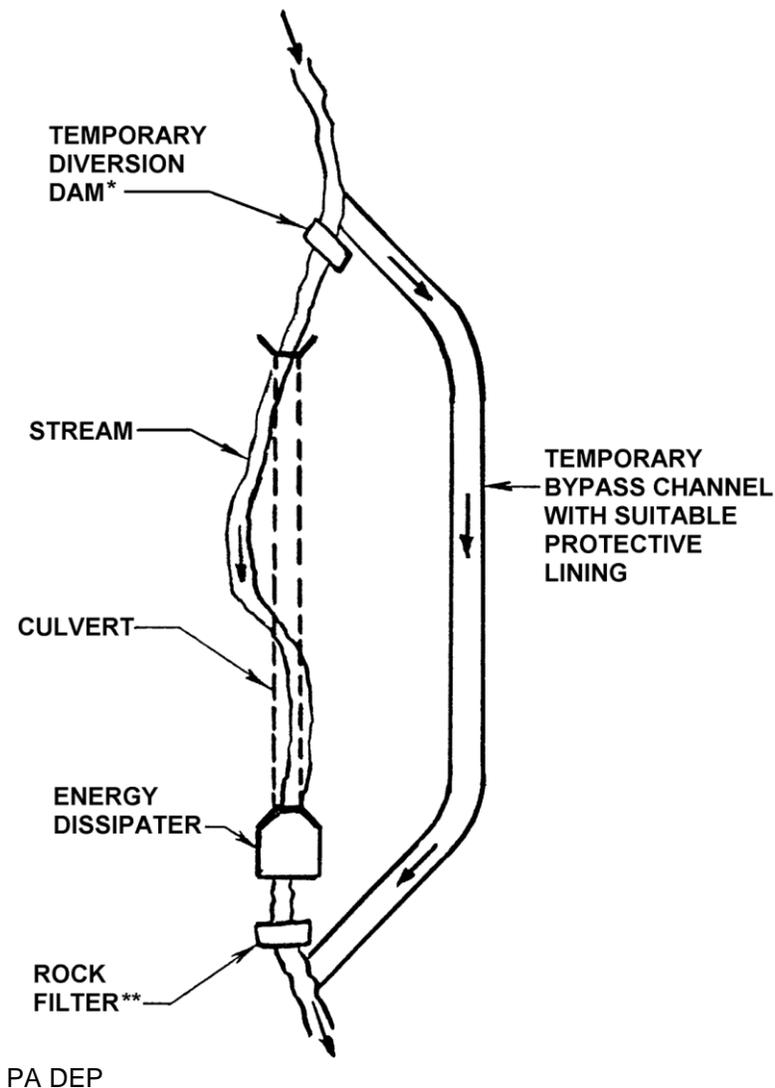
Whenever a temporary bypass pipe is used, it should conform to Figure 3.10. The pipe should be sized so that the normal flow depth — flow typically observed within the channel, not in response to storm or drought events — in the pipe ( $d$ ) is  $\leq \frac{1}{2}$  the diameter of the pipe ( $D$ ).

Pumped water bypass systems should conform to Figure 3.11. Pump-around systems should not be used for bypasses anticipated to last more than 2 weeks. **NOTE: A cofferdam should be constructed to impound water for the pump intake. DO NOT EXCAVATE A SUMP AREA WITHIN THE STREAM CHANNEL FOR THE PUMP INTAKE.**

Whenever an in-stream cofferdam diversion is used, it should conform to Figure 3.12. Various types of cofferdams are available from various manufacturers. Wherever such cofferdams are proposed, they should conform to the manufacturer's specifications. Any calculations needed to show compliance with these specs should be included in the narrative. All installation, maintenance, and removal details should be shown on the plan drawings.

Sand bag diversion dams should conform to Standard Construction Detail #3-15.

**FIGURE 3.9**  
**Bypass Channel with Non-Erosive Lining**

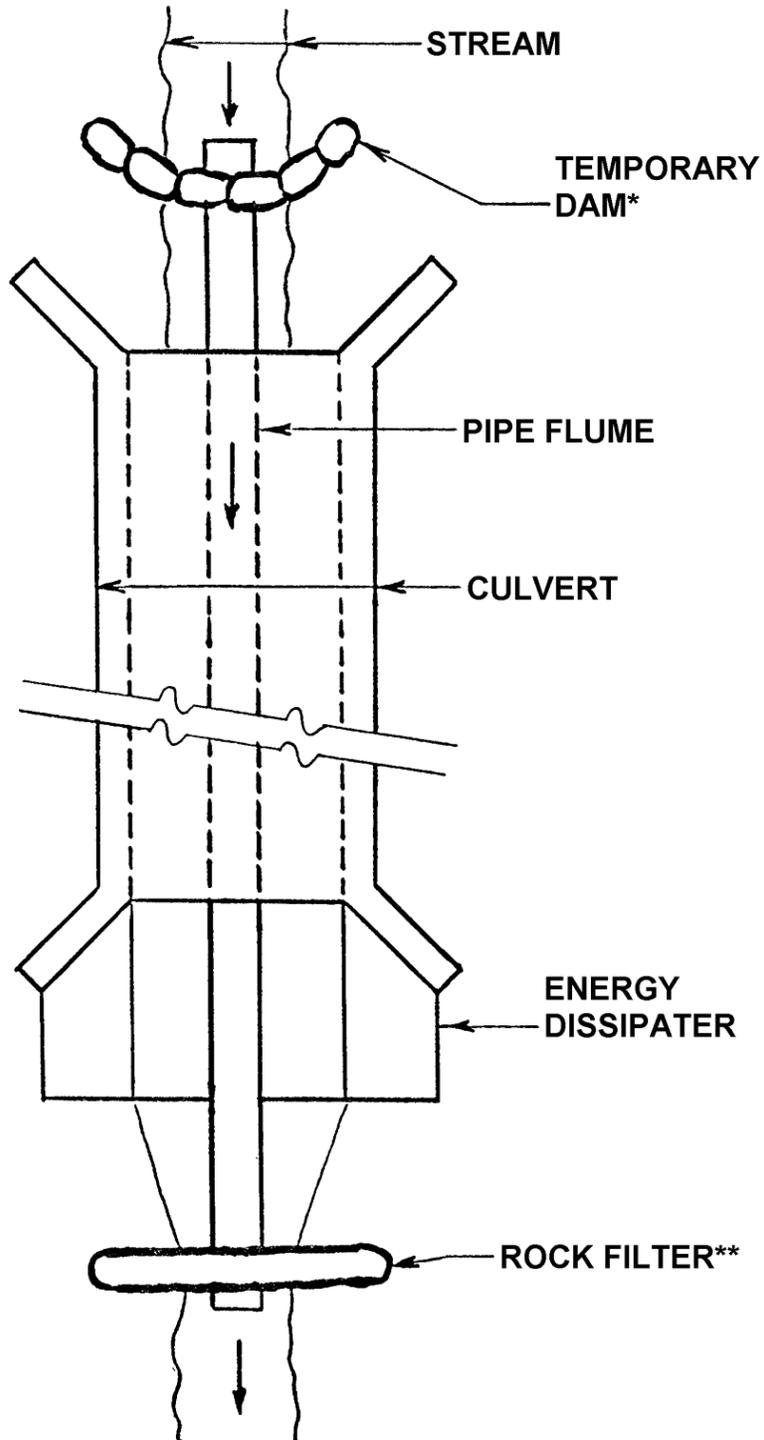


\* Sandbags (Standard Construction Detail #3-15), Jersey barriers (Figure 3.13) or other non-erosive material, no earth fill.

\*\* See Standard Construction Detail # 4-14. For low gradient channels, the rock filter may be replaced by an impervious cofferdam to prevent backflow into the work area.



**FIGURE 3.10**  
**Rigid or Flexible Pipe Flume Through a Work Area**

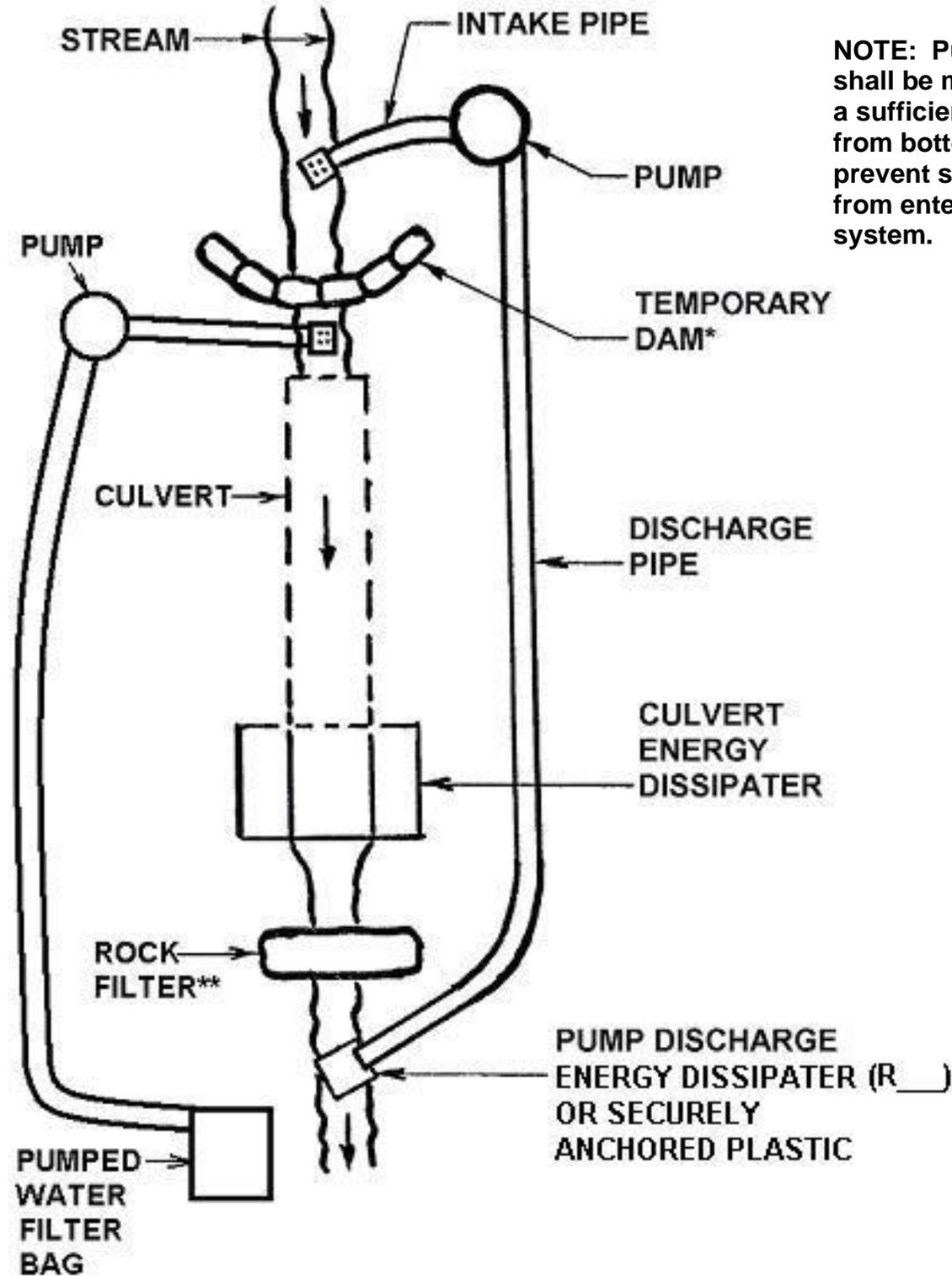


PA DEP

\* Sandbags (Standard Construction Detail #3-15), Jersey barriers (Figure 3.13) or other non-erosive material, no earth fill.

\*\* See Standard Construction Detail # 4-14. For low gradient channels, the rock filter may be replaced by an impervious cofferdam to prevent backflow into the work area.

**FIGURE 3.11**  
**Temporary Cofferdam and Pump Bypass Around In-channel Work Areas**

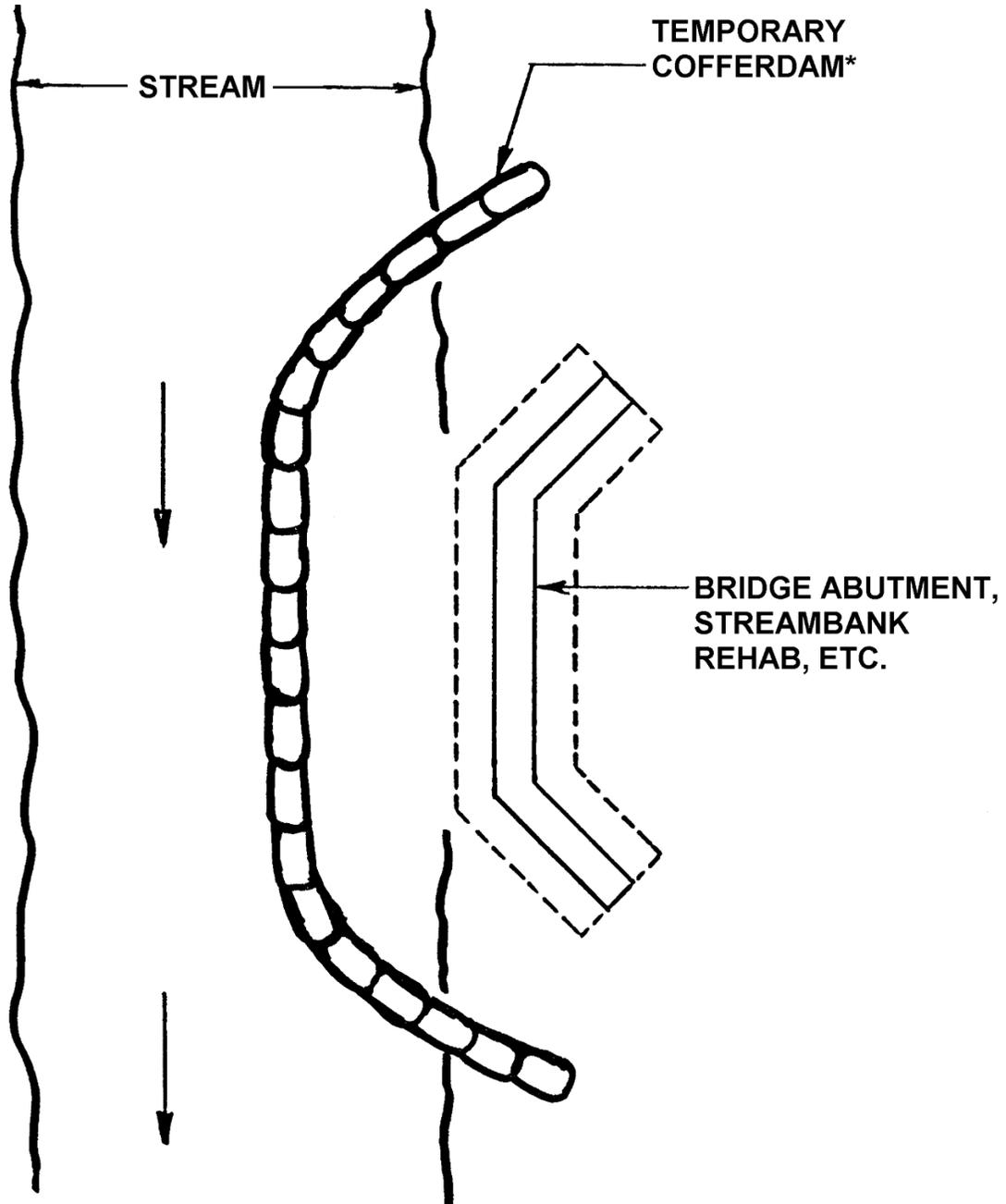


**NOTE:** Pump intake shall be maintained a sufficient distance from bottom to prevent sediment from entering the system.

\* Sandbags (Standard Construction Detail #3-15), Jersey barriers (Figure 3.13) or other non-erosive material, no earth fill. Do not excavate a sump for the pump intake.

\*\* See Standard Construction Detail # 4-14. For low gradient channels, the rock filter may be replaced by an impervious cofferdam to prevent backflow into the work area.

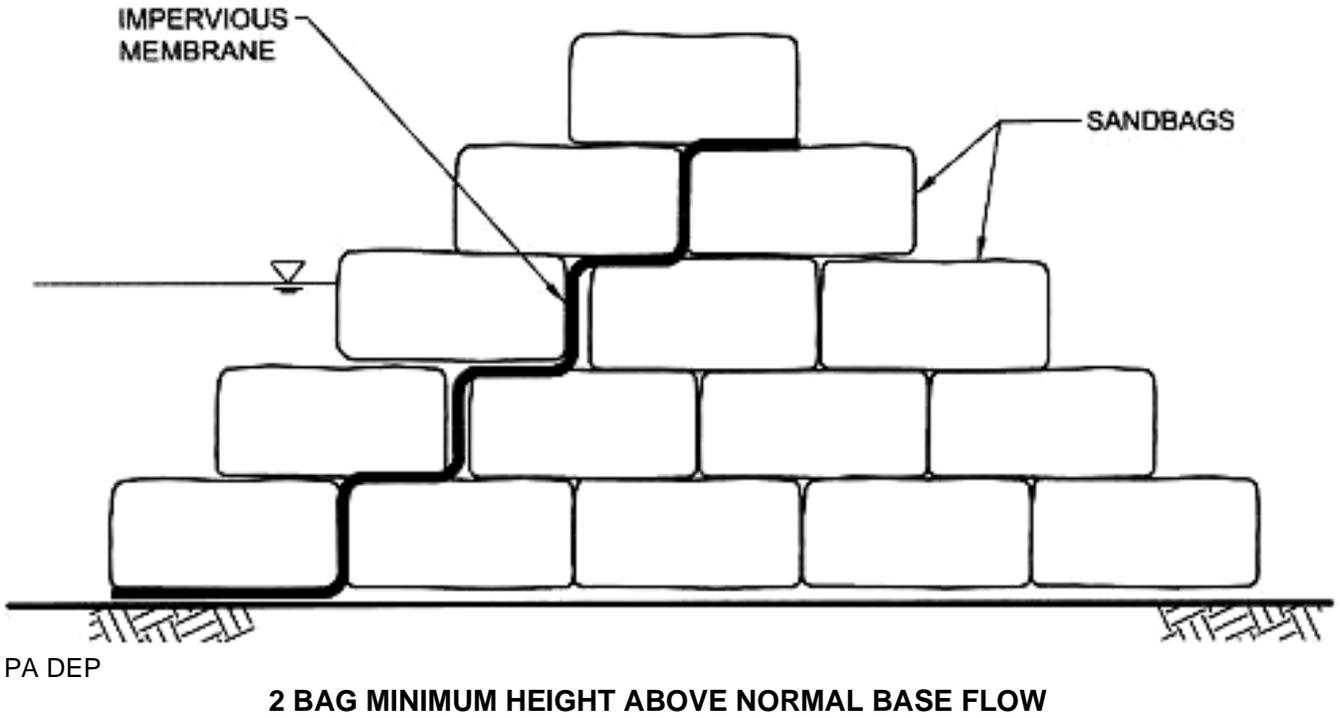
FIGURE 3.12  
In-stream Cofferdam Diversion



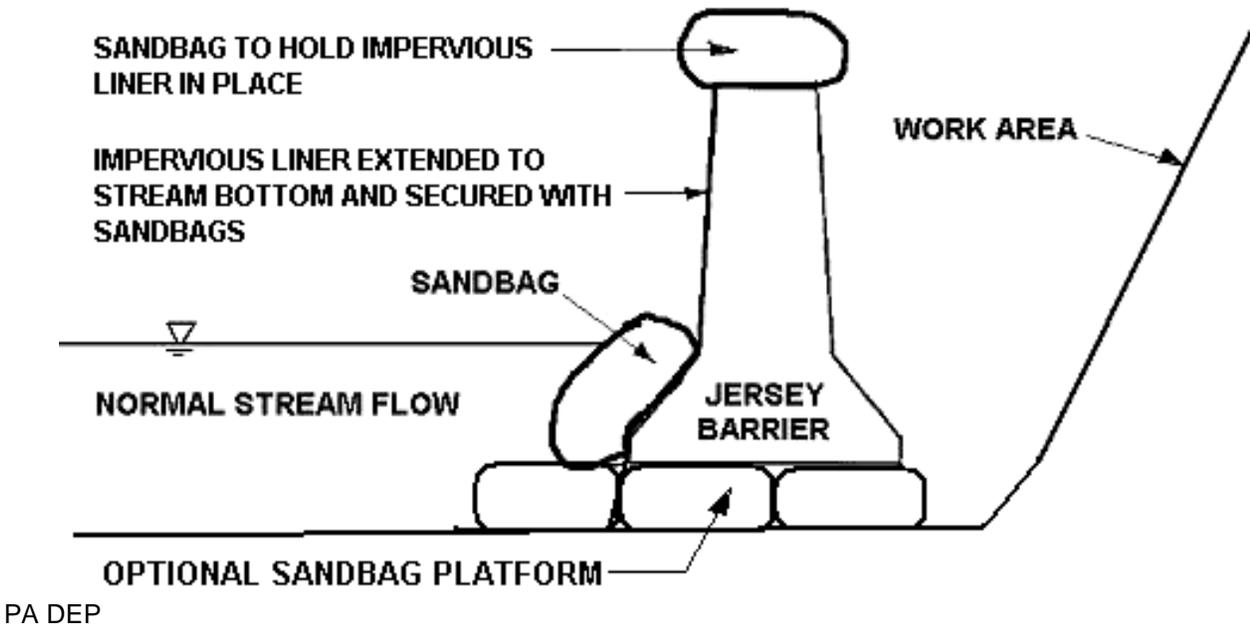
PA DEP

- \* Sandbags (Standard Construction Detail #3-15), Jersey barriers (Figure 3.13) or other non-erosive material, no earth fill.

**STANDARD CONSTRUCTION DETAIL #3-15  
Sandbag Diversion Dam or Cofferdam**



**FIGURE 3.13  
Jersey Barrier Cofferdam – End View**



## EARTHWORK WITHIN LAKES AND PONDS

**NOTE: Wherever the structures described in this section are installed, the appropriate Chapter 105 permits must be obtained from the Department. Designs shall adhere to the conditions of those permits.**

Since the water within a lake or pond typically has no appreciable flow velocity, a cofferdam is usually sufficient to protect impounded water from the turbidity caused by construction activity. Therefore, Figure 3.12 may be modified to provide a typical detail for such activity.

### **Turbidity Barrier (Silt Curtain)**

A turbidity barrier is a heavy geosynthetic fabric suspended vertically in a body of water for the purpose of preventing sediment-laden water from escaping a work area and entering the main body of water. It is typically supported by a floatation system at the top and weighted at the bottom.



Geosol

A turbidity barrier is generally used where earthwork (e.g. dredging operations, streambank improvements, bridge pier construction, etc.) occurs within a water body, or along the shoreline, for relatively short periods of time, usually less than 1 month. It is most effective when used in calm water. Turbidity barriers should not generally be used where strong currents exist, and should never be placed across flowing watercourses. They should not typically be left in place during winter.

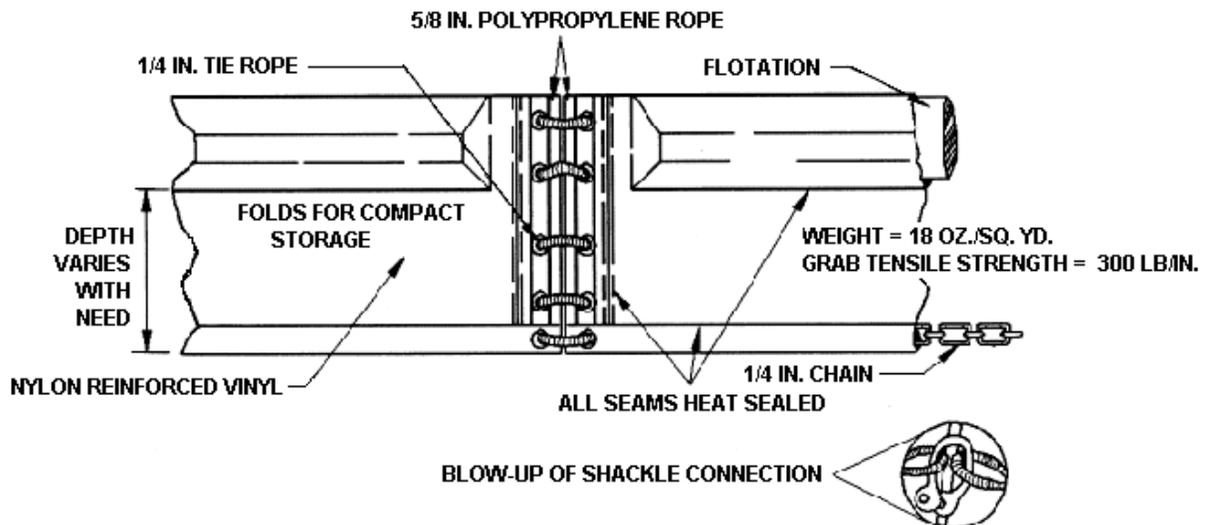
### Design Considerations

- For ponds and other relatively still water bodies, the fabric should be relatively impermeable so as to provide a barrier between the clean water and the sediment-laden water. Runoff into this type of curtain should be minimized, due to limited available capacity.
- For moving water, such as in lakes and stream channels, provision should be made to allow passage of water through the curtain. This is normally done by constructing at least part of the curtain from a heavy filter fabric. While such curtains allow for some water movement through the curtain, the flow rate is low. Therefore, these curtains should not be installed across flowing watercourses. Turbidity barriers placed in stream channels should be placed parallel to the flow direction.

- Wherever the water body is not subject to tidal and/or wind and wave action, the curtain should extend the entire depth of the water and rest on (or be anchored to) the bottom. Failure to maintain contact with the bottom will allow sediment to move under the curtain. It is recommended that the height of the curtain be 20% greater than the depth of the water to allow for fluctuations.
- Wherever the water body is subject to significant tide, wind, or wave action, the weighted bottom of the curtain should not extend to the bottom of the water body. Wind and wave action can cause the bottom of the curtain to move along the bottom, stirring up sediment. Therefore, a minimum 1-foot gap should be provided between the bottom of the curtain and the bottom of the water body at mean low water.
- Curtain heights beyond 12 feet are generally not practical. Curtains installed deeper than this are subject to very large loads with consequent strain on curtain materials and the anchoring system.
- The overall length of the curtain should be 10 - 20% greater than the straight-line measurement of the perimeter to facilitate installation and reduce stress caused by wind and/or waves.
- Both ends of the curtain should be securely anchored to the shoreline.
- An excessive number of joints should be avoided. A minimum continuous span of 50 feet between joints is recommended. For stability purposes, the maximum span between joints should be 100 feet.
- For applications where it is desirable for water to pass through the curtain (e.g. when used instead of a baffle in a sediment basin), a curtain with one or more panels of screen fabric should be used. In this application, the curtain may remain in place over winter months.

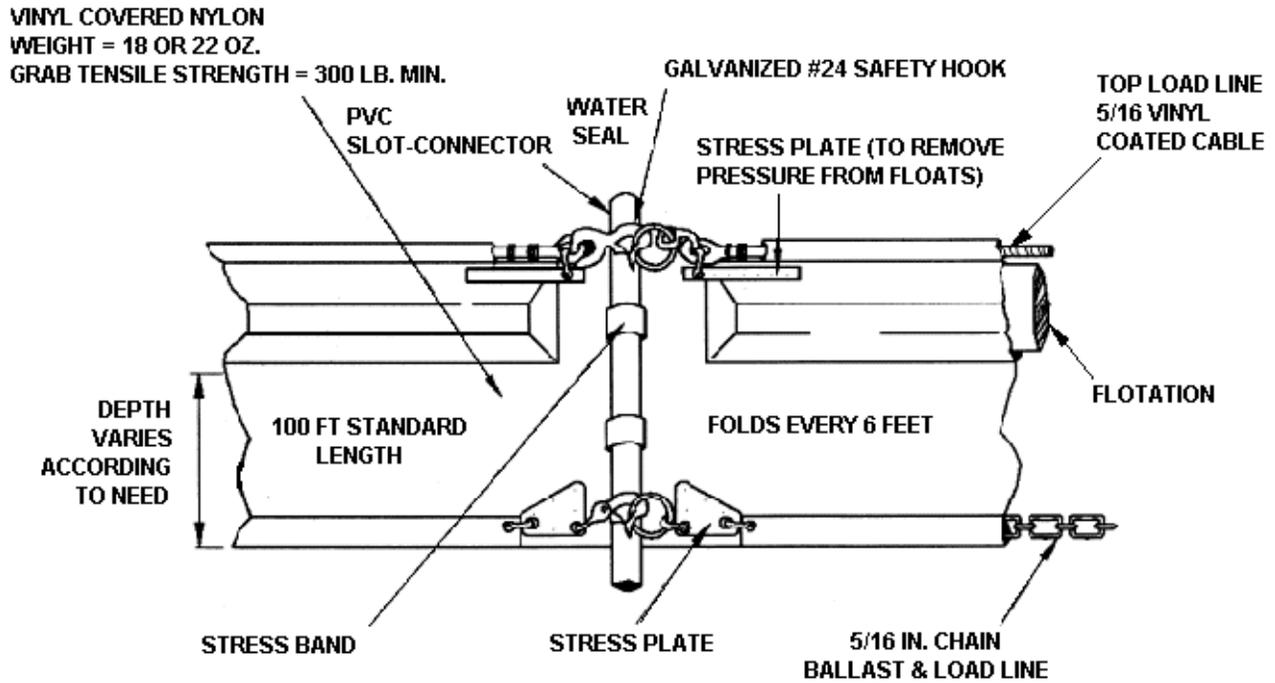
**Installation** - Follow the manufacturer's guidelines for proper installation. Make sure all obstacles, impediments, and potentially damaging objects have been removed from the installation area prior to beginning the installation. Figures 3.14 through 3.17 illustrate typical installations. However, manufacturer's details should be used for actual installation.

**FIGURE 3.14  
Turbidity Barrier Installation  
No Current and Sheltered from Wind and Waves**



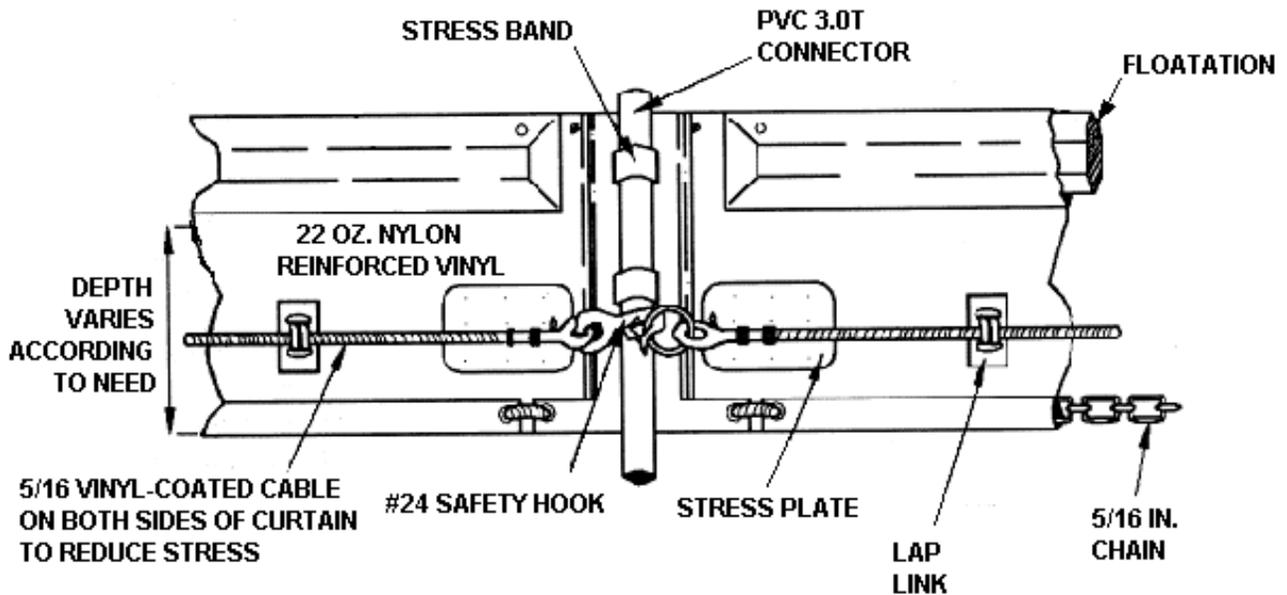
Adapted from VA DSWC

**FIGURE 3.15**  
**Turbidity Barrier Installation**  
**Small to Moderate Current ( $\leq 3.5$  FPS) and Some Wind and Wave Action**



Adapted from VA DSWC

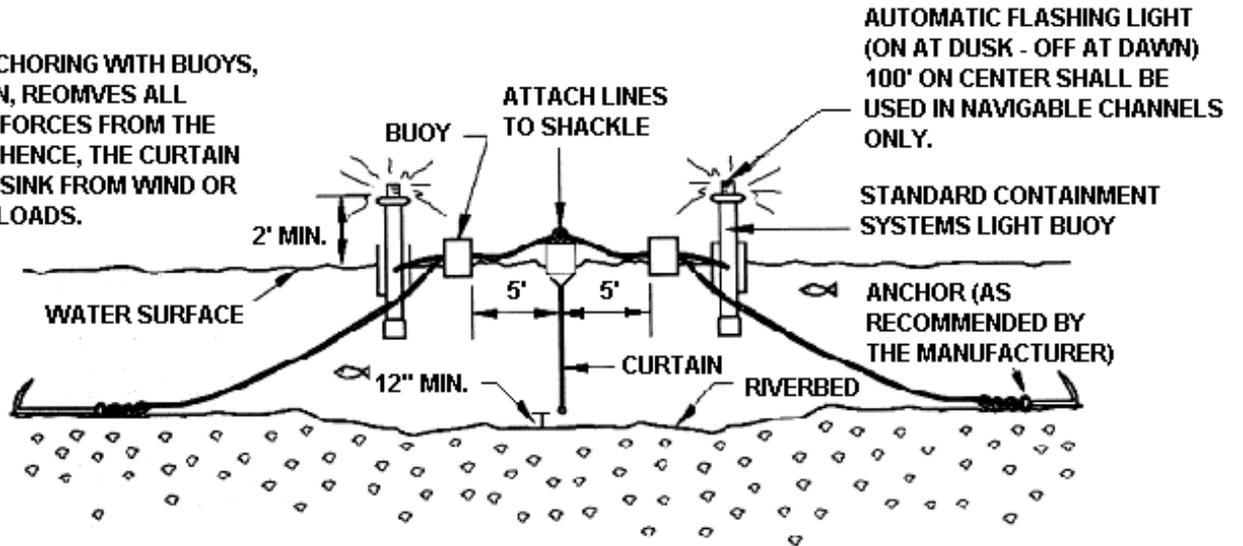
**FIGURE 3.16**  
**Turbidity Barrier Installation**  
**Considerable Current (3.5 - 5 FPS) and Potential Tidal, Wind, and Wave Action**



Adapted from VA DSWC

**FIGURE 3.17**  
**Turbidity Barrier Installation - Tidal Condition**

NOTE: ANCHORING WITH BUOYS, AS SHOWN, REMOVES ALL VERTICAL FORCES FROM THE CURTAIN. HENCE, THE CURTAIN WILL NOT SINK FROM WIND OR CURRENT LOADS.



Adapted from VA DSWC



**DEWATERING WORK AREAS** - Wherever water is pumped from a disturbed area, it must be treated for sediment removal prior to discharging to a surface water unless it can be shown that the quality of the water being pumped already meets discharge standards. If a properly functioning sediment basin or sediment trap is available, the pump discharge may be routed through the trap or basin. While pumping, the maximum water level in the trap or basin should not exceed the cleanout elevation. Water pumped from disturbed areas may not be discharged directly to detention ponds, since they are not designed to be efficient sediment removal structures. Straw bale structures and filter fabric structures are not acceptable for filtering pumped water due to their history of ineffectiveness. Filter bags, as shown in Standard Construction Detail #3-16, and Sump Pits, as shown in Standard Construction Detail #3-17, may be used to filter pumped water as described in the following section. Other devices for filtering water pumped from excavations will be reviewed on a case-by-case basis.

The topography and conditions of the ground cover between the discharge point and the receiving surface water should be evaluated for potential erosion. Appropriate stabilization measures should be incorporated where needed to prevent erosion.

**No filtering device is required for water pumped directly from a stream channel as part of a pump-around bypass system.**

**PUMPED WATER FILTER BAG - Sediment Removal Efficiency: LOW. This device is not an ABACT for special protection watersheds unless surrounded by a compost sock ring or operated in conjunction with a sump pit.** Filter bags may be used to filter water pumped from disturbed areas prior to discharging to surface waters. They may also be used to filter water pumped from the sediment storage areas of sediment basins and sediment traps.

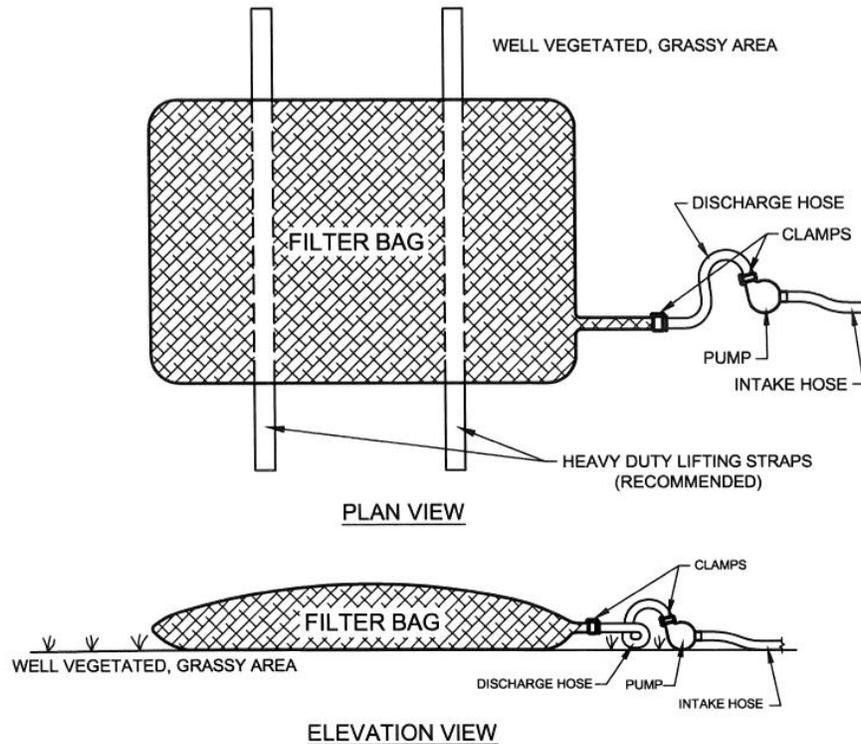


Northampton County Conservation District

The maximum pumping rate for any bag in use or proposed for use on a site should be available at the site at all times during pumping operations. Pumping rates will vary depending on the size of the filter bag, and the type and amount of sediment discharged to the bag.

Filter bags should be installed according to the details shown in Standard Construction Detail #3-16.

## STANDARD CONSTRUCTION DETAIL # 3-16 Pumped Water Filter Bag



PA DEP

Low volume filter bags shall be made from non-woven geotextile material sewn with high strength, double stitched “J” type seams. They shall be capable of trapping particles larger than 150 microns. High volume filter bags shall be made from woven geotextiles that meet the following standards:

Property	Test Method	Minimum Standard
Avg. Wide Width Strength	ASTM D-4884	60 lb/in
Grab Tensile	ASTM D-4632	205 lb
Puncture	ASTM D-4833	110 lb
Mullen Burst	ASTM D-3786	350 psi
UV Resistance	ASTM D-4355	70%
AOS % Retained	ASTM D-4751	80 Sieve

A suitable means of accessing the bag with machinery required for disposal purposes shall be provided. Filter bags shall be replaced when they become ½ full of sediment. Spare bags shall be kept available for replacement of those that have failed or are filled. Bags shall be placed on straps to facilitate removal unless bags come with lifting straps already attached.

Bags shall be located in well-vegetated (grassy) area, and discharge onto stable, erosion resistant areas. Where this is not possible, a geotextile underlayment and flow path shall be provided. Bags may be placed on filter stone to increase discharge capacity. Bags shall not be placed on slopes greater than 5%. For slopes exceeding 5%, clean rock or other non-erodible and non-polluting material may be placed under the bag to reduce slope steepness.

No downslope sediment barrier is required for most installations. Compost berm or compost filter sock shall be installed below bags located in HQ or EV watersheds, within 50 feet of any receiving surface water or where grassy area is not available.

**(Additional Notes for Standard Construction Detail # 3-16)**

**The pump discharge hose shall be inserted into the bags in the manner specified by the manufacturer and securely clamped. A piece of PVC pipe is recommended for this purpose.**

**The pumping rate shall be no greater than 750 gpm or ½ the maximum specified by the manufacturer, whichever is less. Pump intakes shall be floating and screened.**

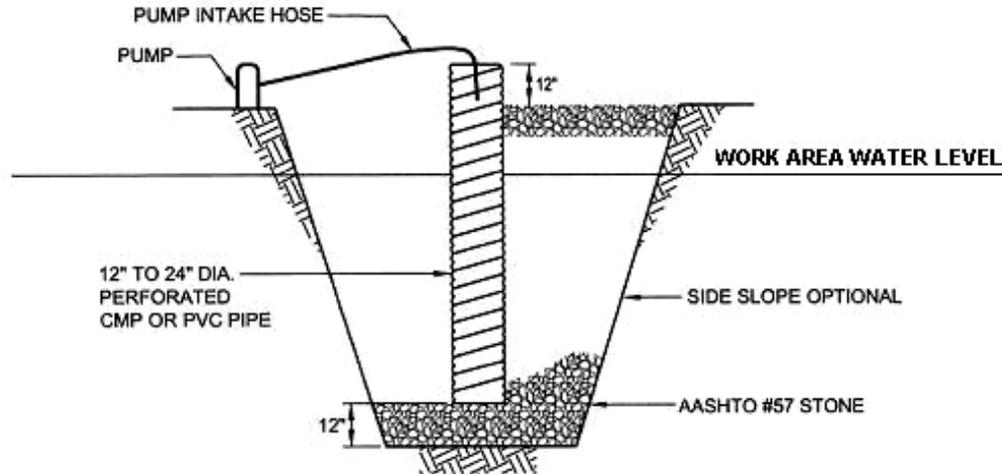
**Filter bags shall be inspected daily. If any problem is detected, pumping shall cease immediately and not resume until the problem is corrected.**

**SUMP PIT - Sediment Removal Efficiency: LOW. This device is not an ABACT for special protection watersheds unless used in conjunction with a pumped water filter bag.** For sites where large volumes of water of low to moderate turbidity (i.e. not flowing from or through work areas) must be pumped from work areas, and many filter bags would be required, sump pits (Standard Construction Detail #3-17) can provide a means of filtering the water. They may also be used in conjunction with filter bags to reduce the amount of sediment being pumped into the bags, reducing the number of bags required. Sump pits used in conjunction with filter bags may also be used as an ABACT BMP in special protection watersheds. Sump pits should not be used alone where highly turbid waters are being pumped such as typically results from active work areas.

Sump pits should be located at a low point in the work area so that the water naturally drains toward the pit. The size of the pit required depends upon the amount of water that must be pumped from the work area and the space available.

When used in conjunction with a filter bag, the intake of the pump going to the filter bag should be inserted into the standpipe of the sump pit.

## STANDARD CONSTRUCTION DETAIL #3-17 Sump Pit



Adapted from USDA NRCS

Locate sump at low point in work area and outside of construction activity. Wherever runoff from a work area flows directly to the sump area, a filter bag shall be attached at the discharge point unless pumping to a sediment basin or sediment trap.

Minimum diameter of pit bottom shall be 24" larger than pipe diameter. Minimum depth of pit shall be 24" below water level in work area (including the AASHTO #57 stone). 12" to 24" perforated CMP or PVC pipe shall be set on 12" of clean AASHTO # 57 stone.

Void space around pipe shall be filled with AASHTO # 57 stone. Pipe to extend 12" min. above top of stone and/or water being pumped from work area.

Set pump intake inside standpipe.

Discharge from pump shall be to a stable area below disturbances from the work zone.

Sump may be used in conjunction with filter bag where additional filtering is needed.

## SITE HOUSEKEEPING AND MATERIALS MANAGEMENT

**WASTE MANAGEMENT** - Building materials and other construction site wastes must be properly managed and disposed of to reduce potential for pollution to surface and ground waters as per 25 Pa. Code § 102.4(b)(5)(xi). Proper trash disposal, recycling of materials, proper materials handling, and spill prevention and clean-up reduce the potential for construction site wastes to be mobilized by stormwater runoff and conveyed to surface waters.

Under no circumstances may erosion control BMPs be used for temporary storage of demolition materials or construction wastes.

Wherever heavy equipment will be used during construction of the cuts and fills or proposed buildings, a Pollution Prevention and Contingency (PPC) plan must be available on site. This plan does not have to be included in the permit application package submitted for an NPDES construction permit in Pennsylvania but should be available on the project site. The applicant must prepare and implement a PPC plan when storing, using or transporting materials including: fuels, chemicals, solvents, pesticides, fertilizers, lime, petrochemicals, wastewater, wash water, core drilling wastewater, cement, sanitary wastes, solid wastes, or hazardous materials onto, on, or from the project site during earth disturbance activities. The PPC plan must be available upon request by the Department or conservation district. Guidance for development of a PPC plan can be found in "Guidelines for the Development and Implementation of Environmental Emergency Response Plans" (Document #400-2200-001), which can be found in the Department's eLibrary at [www.depweb.state.pa.us](http://www.depweb.state.pa.us).

All applicable federal, state, and local laws and regulations must be followed in the use, handling, and disposal of potentially hazardous materials.

**CONCRETE WASHOUT** - For any project on which concrete will be poured or otherwise formed on site, a suitable washout facility must be provided for the cleaning of chutes, mixers, and hoppers of the delivery vehicles unless such a facility will be used at the source of the concrete. Under no circumstances may wash water from these vehicles be allowed to enter any surface waters. Make sure that proper signage is provided to drivers so that they are aware of the presence of washout facilities.

Washout facilities should not be placed within 50 feet of storm drains, open ditches or surface waters. They should be in a convenient location for the trucks, preferably near the place where the concrete is being poured, but far enough from other vehicular traffic to minimize the potential for accidental damage or spills. Wherever possible, they should be located on slopes not exceeding a 2% grade. Additional information on washouts may be obtained from EPA's stormwater website at: <http://cfpub.epa.gov/npdes/stormwater/menuofbmps/index.cfm?action=browse&Rbutton=detail&bmp=117&minmeasure=4>.

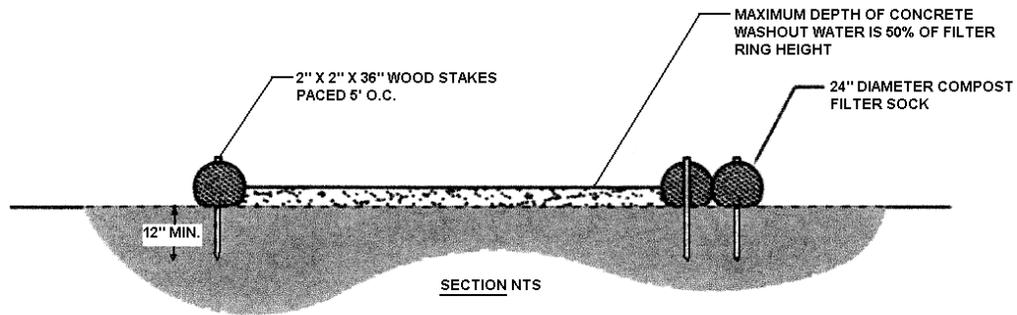
### Compost Sock Washout

Wherever compost sock washouts are used, a suitable impervious geomembrane should be placed at the location of the washout. Compost socks should be staked in the manner recommended by the manufacturer around perimeter of the geomembrane so as to form a ring with the ends of the sock located at the upslope corner (Figure 3.18). Care should be taken to ensure continuous contact of the sock with the geomembrane at all locations. Where necessary, socks may be stacked and staked so as to form a triangular cross-section.

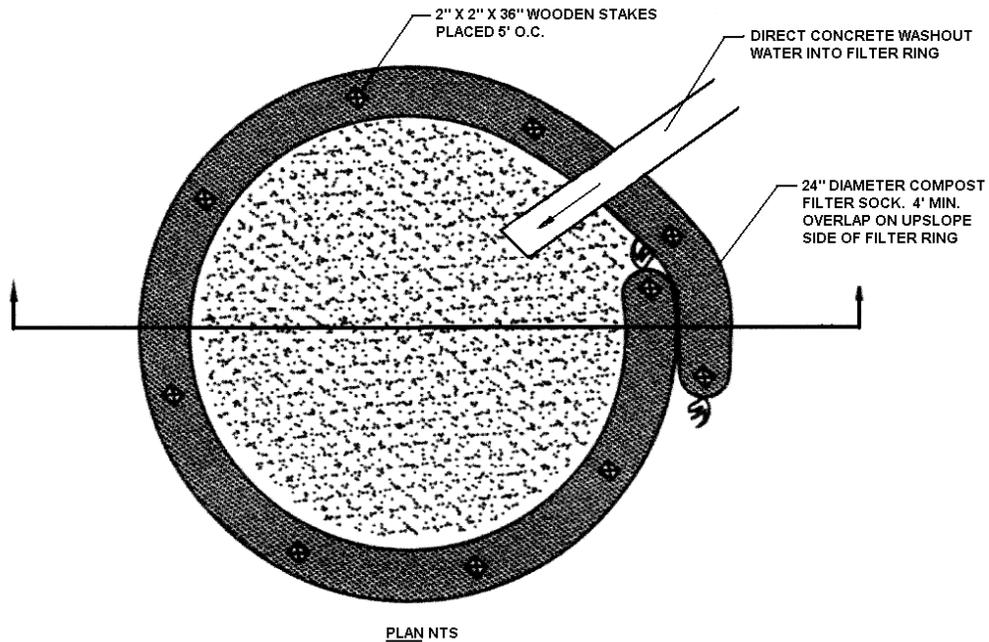


Filtrex

**FIGURE 3.18**  
**Typical Compost Sock Washout Installation**



- NOTES:
1. INSTALL ON FLAT GRADE FOR OPTIMUM PERFORMANCE
  2. 18" DIAMETER FILTER SOCK MAY BE STACKED ONTO DOUBLE 24" DIAMETER SOCKS IN PYRAMIDAL CONFIGURATION FOR ADDED HEIGHT.



**A suitable impervious geomembrane shall be placed at the location of the washout prior to installing the socks.**

Adapted from Filtrex

## Prefabricated Washout Containers

Care should be taken to ensure that the containers are intended by the manufacturer for use as concrete washout BMPs, that they are watertight, and appropriately sized. Accumulated materials must be properly disposed of (preferably recycled) when they reach the cleanout level.



All World Equipment

## Self-installed Washouts

These types of washouts should be excavated below grade to prevent runoff of the wash water and minimize the potential for breaching. They should be sized to handle solids, wash water, and rainfall. A good rule of thumb is that 7 gallons of wash water are required to wash one truck chute and 50 gallons for the hopper of a concrete pump truck.

For larger sites, a below-grade washout should be a minimum of 10 feet wide and provide at least 12 inches of freeboard above the liquid and solid waste anticipated between cleanout intervals. The pit should be lined with plastic sheeting of at least 10-mil thickness (with no holes or tears) to prevent leaching of liquids into the ground.



PA DEP

### Washwater Recycling Systems

Washwater recycling systems have also been developed which separate the solids from the washwater, capturing both in impermeable bags and allowing them to be recycled. These systems may be used in lieu of washouts if manufacturers' specifications are followed. Care must be taken to prevent the filtered water from entering any surface waters.

### Sediment Basins and Sediment Traps

Sediment basins and sediment traps may not be used as concrete washout devices, since they discharge directly to surface waters. This discharge would have an adverse effect upon the receiving water. In addition, continued use of a basin or trap as a washout facility would significantly reduce the storage capacity of the basin or trap.

### Maintenance

All concrete washout facilities should be inspected daily. Damaged or leaking washouts should be deactivated and repaired or replaced immediately.

Accumulated materials should be removed when they reach 75% capacity.

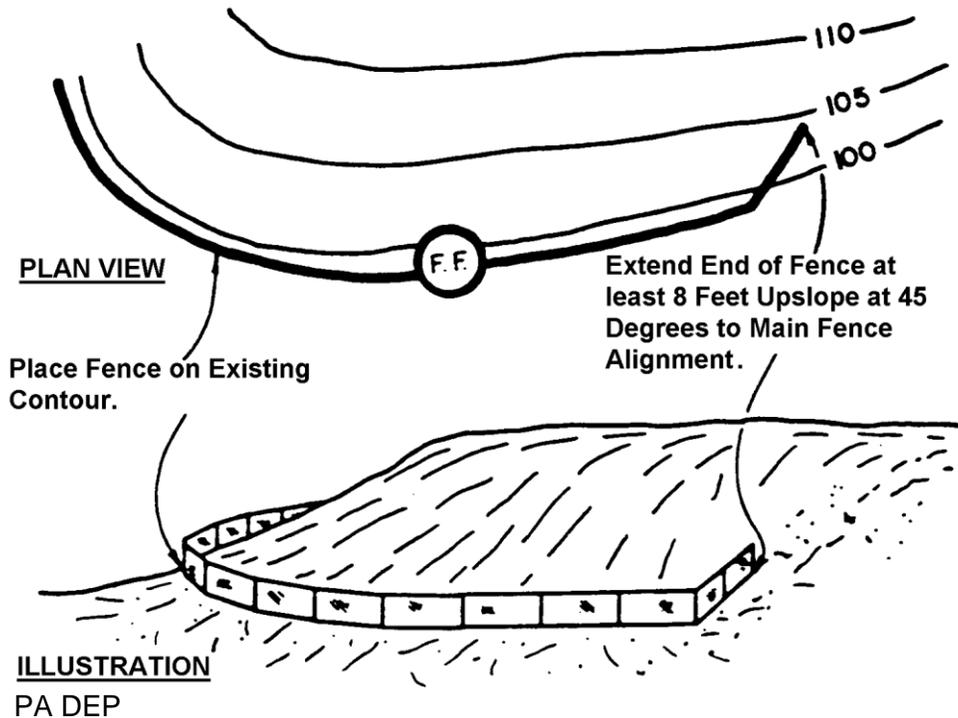
Plastic liners should be replaced with each cleaning of the washout facility.



## CHAPTER 4 - SEDIMENT BARRIERS AND FILTERS

Sediment barriers are typically used as perimeter controls for small disturbed areas and as initial protection against sediment pollution during construction of other BMPs such as sediment basins or traps. Each type of sediment barrier has specific advantages and limitations. Care should be exercised in the selection of any sediment barrier to ensure it is suited to the particular site conditions where it is proposed.

**FIGURE 4.1**  
**Sediment Barrier Alignment**



Sediment barriers should be installed on existing level grade in order to be effective. Barriers which cross contours divert runoff to a low point where failure usually occurs. The ends of sediment barriers should be turned upslope at 45 degrees to the main barrier alignment for a distance sufficient to elevate the bottom of the barrier ends to the elevation of the top of the barrier at the lowest point. This is to prevent runoff from flowing around the barrier rather than through it. For most locations, a distance of 8 feet will suffice, as shown in Figure 4.1. In locations where the topography is such that the barrier would have to extend for a long distance, a compacted berm tying into the ends of the barrier may be substituted for the upslope extension.

**COMPOST FILTER SOCK - Sediment Removal Efficiency: HIGH. This device is an ABACT for HQ and EV watersheds.** Compost filter socks are a type of contained compost filter berm. They consist of a biodegradable or photodegradable mesh tube filled, typically using a pneumatic blower, with a coarse compost filter media that meets certain performance criteria (e.g. hydraulic flow through

rate, total solids removal efficiency, total suspended solids removal efficiency, turbidity reduction, nutrient removal efficiency, metals removal efficiency, and motor oil removal efficiency).



York County Conservation District

Compost filter socks are flexible and can be filled in place or in some cases filled and moved into position. They are especially useful on steep slopes. Heavy vegetation should be removed prior to installing the sock. Compost socks can also be used on rocky slopes if sufficient preparation is made to ensure good contact of the sock with the underlying soil along its entire length. They may also be used on pavement as a perimeter control. Socks used in this manner range in diameter from 8" to 32". **Note: The flat dimension of the sock should be at least 1.5 times the nominal diameter. Also, some settlement of the tube typically occurs after installation.** The nominal diameter of the tube is the dimension to be used for design purposes (i.e. Figure 4.2). Socks with diameters less than 12" should only be used for residential housing lots of ¼ acre or less that are tributary to a sediment basin or sediment trap.

As with other sediment barriers, compost socks should not be placed in areas of concentrated flow. They should be placed parallel to contour with both ends of the sock extended upslope at a 45 degree angle to the rest of the sock to prevent end-arounds (Figure 4.1). Socks placed on earthen slopes should be anchored with stakes driven through the center of the sock (Standard Construction Detail #4-1) or immediately downslope of the sock at intervals recommended by the manufacturer. Where socks are placed on paved surfaces, concrete blocks should be used immediately downslope of the socks (at the same intervals recommended for the stakes) to help hold the sock in place.

The maximum slope length above a compost filter sock should not exceed those shown in Figure 4.2. **NOTE: Slope length is not addressed by use of multiple rows of compost socks.** The anticipated functional life of a biodegradable filter sock should be 6 months; for photodegradable socks it is 1 year.

Some other types may last longer. Projects with disturbances anticipated to last longer than the functional life of a sock should plan to replace the socks periodically or use another type of BMP.

Upon stabilization of the tributary area, the filter sock may be left in place and vegetated or removed. In the latter case, the mesh is typically cut open and the mulch spread as a soil supplement. In either case, the stakes should be removed.

Filter socks using other fillers may be approved on a case-by-case basis if sufficient supporting information (including manufacturer's specs and independent test data) is provided. However, they might not qualify as ABACTs. Wherever compost socks are used, Table 4.1 should be placed on a detail sheet.

**TABLE 4.1  
Compost Sock Fabric Minimum Specifications**

<b>Material Type</b>	<b>3 mil HDPE</b>	<b>5 mil HDPE</b>	<b>5 mil HDPE</b>	<b>Multi-Filament Polypropylene (MFPP)</b>	<b>Heavy Duty Multi-Filament Polypropylene (HDMFPP)</b>
<b>Material Characteristics</b>	Photo-degradable	Photo-degradable	Bio-degradable	Photo-degradable	Photo-degradable
<b>Sock Diameters</b>	12" 18"	12" 18" 24" 32"	12" 18" 24" 32"	12" 18" 24" 32"	12" 18" 24" 32"
<b>Mesh Opening</b>	3/8"	3/8"	3/8"	3/8"	1/8"
<b>Tensile Strength</b>		26 psi	26 psi	44 psi	202 psi
<b>Ultraviolet Stability % Original Strength (ASTM G-155)</b>	23% at 1000 hr.	23% at 1000 hr.		100% at 1000 hr.	100% at 1000 hr.
<b>Minimum Functional Longevity</b>	6 months	9 months	6 months	1 year	2 years
<b>Two-ply systems</b>					
<b>Inner Containment Netting</b>	<b>HDPE biaxial net</b>				
	<b>Continuously wound</b>				
	<b>Fusion-welded junctures</b>				
<b>Outer Filtration Mesh</b>	<b>3/4" X 3/4" Max. aperture size</b>				
	<b>Composite Polypropylene Fabric (Woven layer and non-woven fleece mechanically fused via needle punch)</b>				
	<b>3/16" Max. aperture size</b>				
<b>Sock fabrics composed of burlap may be used on projects lasting 6 months or less.</b>					

Filtrexx & JMD

Compost should be a well decomposed, weed-free organic matter derived from agriculture, food, stump grindings, and yard or wood/bark organic matter sources. The compost should be aerobically composted. The compost should possess no objectionable odors and should be reasonably free (<1% by dry weight) of man-made foreign matter. The compost product should not resemble the raw material from which it was derived. Wood and bark chips, ground construction debris or reprocessed wood products are not acceptable as the organic component of the mix.

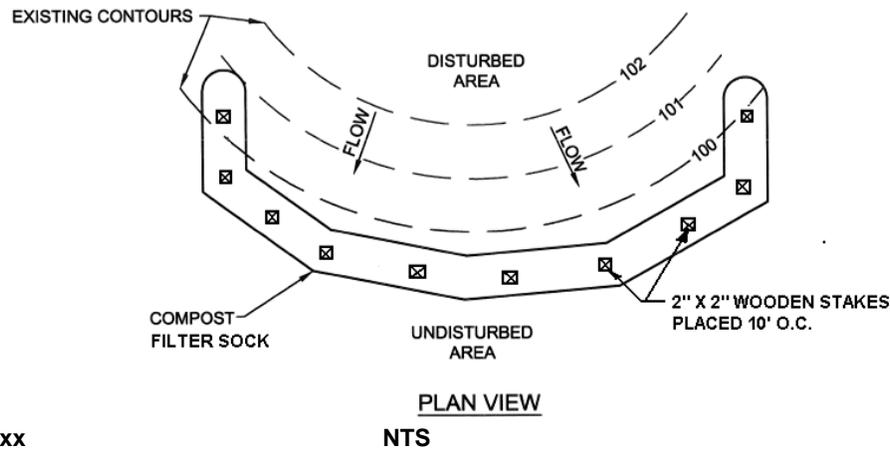
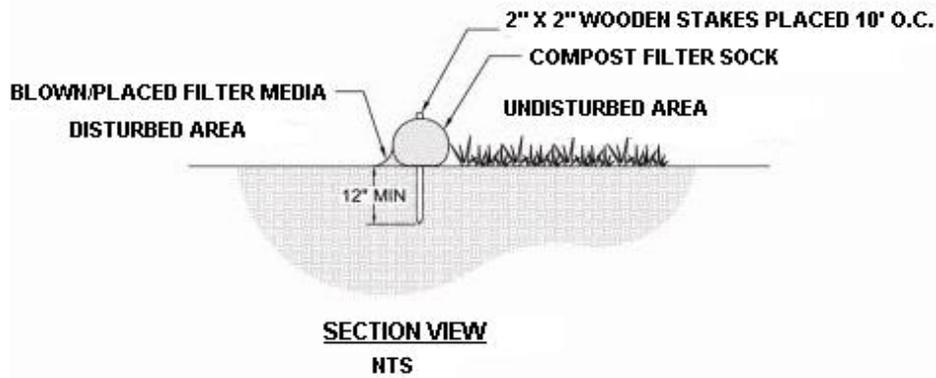
The physical parameters of the compost should comply with the standards in Table 4.2. The standards contained in the PennDOT Publication 408 are an acceptable alternative.

**TABLE 4.2**  
**Compost Standards**

Organic Matter Content	25% - 100% (dry weight basis)
Organic Portion	Fibrous and elongated
pH	5.5 - 8.5
Moisture Content	30% - 60%
Particle Size	30% - 50% pass through 3/8" sieve
Soluble Salt Concentration	5.0 dS/m (mmhos/cm) Maximum

Filtrexx

## STANDARD CONSTRUCTION DETAIL #4-1 COMPOST FILTER SOCK



Filtrexx

NTS

**Sock fabric shall meet standards of Table 4.1. Compost shall meet the standards of Table 4.2.**

**Compost filter sock shall be placed at existing level grade. Both ends of the sock shall be extended at least 8 feet up slope at 45 degrees to the main sock alignment (Figure 4.1). Maximum slope length above any sock shall not exceed that shown on Figure 4.2. Stakes may be installed immediately downslope of the sock if so specified by the manufacturer.**

**Traffic shall not be permitted to cross filter socks.**

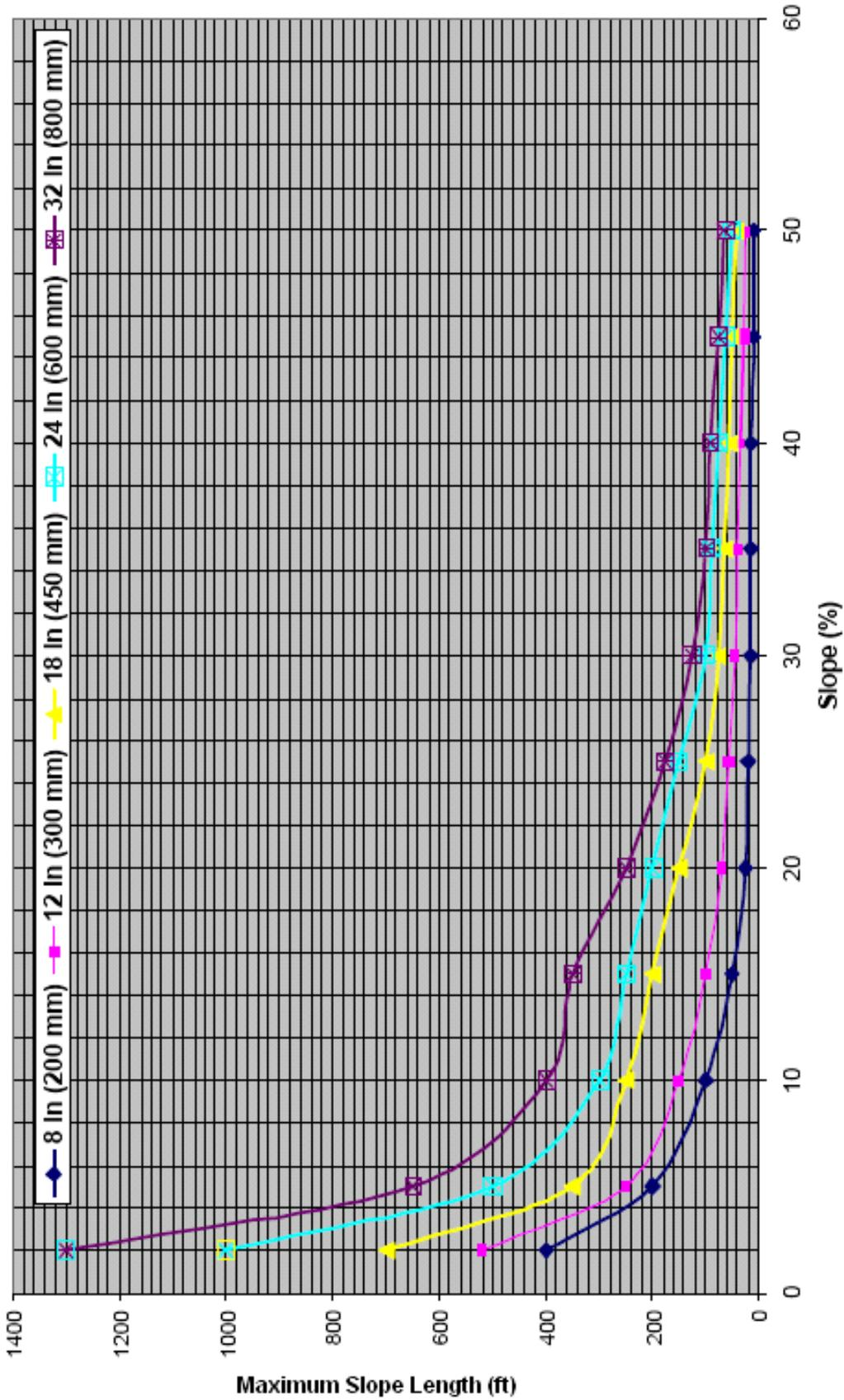
**Accumulated sediment shall be removed when it reaches half the aboveground height of the sock and disposed in the manner described elsewhere in the plan.**

**Socks shall be inspected weekly and after each runoff event. Damaged socks shall be repaired according to manufacturer's specifications or replaced within 24 hours of inspection.**

**Biodegradable filter socks shall be replaced after 6 months; photodegradable socks after 1 year. Polypropylene socks shall be replaced according to manufacturer's recommendations.**

**Upon stabilization of the area tributary to the sock, stakes shall be removed. The sock may be left in place and vegetated or removed. In the latter case, the mesh shall be cut open and the mulch spread as a soil supplement.**

**FIGURE 4.2**  
**MAXIMUM PERMISSIBLE SLOPE LENGTH ABOVE COMPOST FILTER SOCKS**



**NOTE: 8" diameter socks should only be used to control small ( $\leq 1/4$  acre) disturbed areas on individual house lots).**

Adapted from Filtrexx

**COMPOST FILTER BERM - Sediment Removal Efficiency: MODERATE. This device is an ABACT for HQ but not EV watersheds unless used in conjunction with another BMP (e.g. silt fence or vegetative filter strip).** Although compost is typically viewed as a means of stabilization, it may also be used to construct a filter berm for sediment control. Composts denser in nature and containing particles that range in size produce the most stable berms. Do not use compost filter berms in channels or other concentrated flows. As with other types of sediment barriers, compost filter berms should be located where runoff is anticipated to be in sheet flow. Concentrated or channelized flows should be directed to sediment basins or traps, not filter berms. The maximum slope length above a compost filter berm should be that shown in Table 4.4 for the standard silt fence (18" high fence).

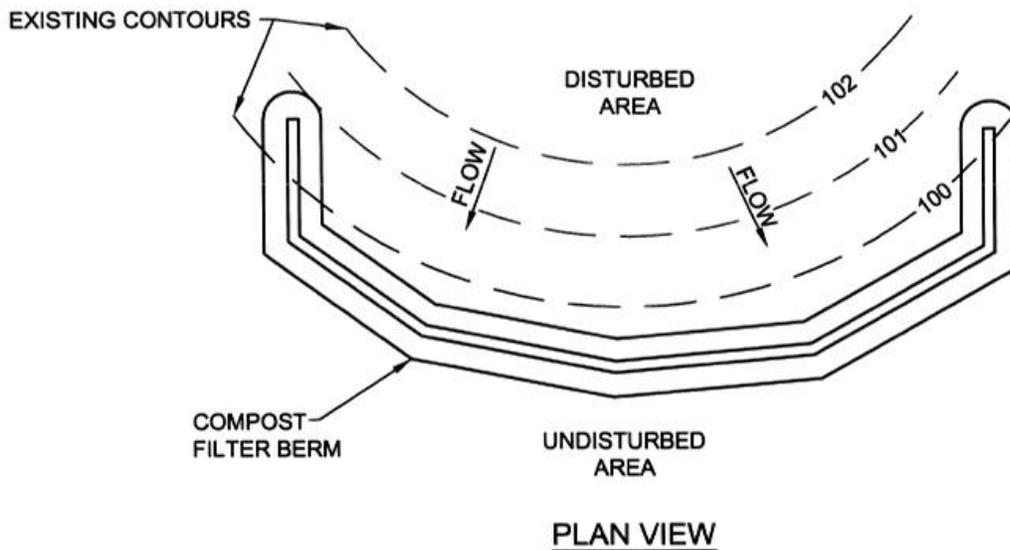
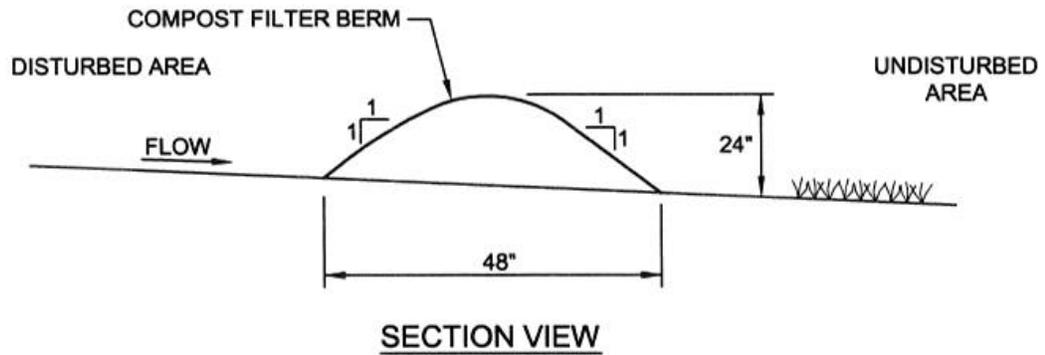


Carolina Compost

Compost filter berms may be vegetated or unvegetated. Vegetated filter berms are usually left in place and provide long-term filtration of stormwater as a post-construction BMP. Unvegetated berms are typically broken down after stabilization of the tributary drainage area is achieved. The compost is spread around the site as a soil amendment or mulch.

Compost filter berms may not be used to construct sediment traps or other impoundments.

**STANDARD CONSTRUCTION DETAIL #4-2  
Compost Filter Berm**



Adapted from PennDOT

**Compost shall meet the standards in Table 4.2.**

**Compost filter berms shall be placed at existing level grade. Both ends of the berm shall be extended at least 8 feet up slope at 45 degrees to the main berm alignment (see Figure 4.1).**

**The maximum slope length above a compost filter berm shall not exceed that shown in Table 4.4 for the standard silt fence (18" high fence).**

**Tall grass shall be cut prior to installation to minimize potential for undercutting. Berm shall be netted or otherwise anchored after installation.**

**Sediment shall be removed when accumulations reach 1/3 the aboveground height of the berm.**

**Any section compost filter berm which has been undermined or topped shall be immediately replaced. Concentrated flows shall not be directed toward any compost filter berm.**



**Installation** - Compost filter berms may be installed by hand, by using construction equipment (e.g. backhoe, wheel loader, or skid loader), or with specialized equipment such as a pneumatic blower or side discharge spreader with a berm attachment. The compost should be uniformly applied to the soil surface, compacted, and shaped into a rough trapezoid. Filter berms may be installed on frozen or rocky ground. Heavy vegetation should be cut down or removed to ensure proper contact with the underlying soil surface.

Vegetated berms may be seeded by hand, by incorporating seed into the compost prior to installation — a typical procedure when installed by pneumatic blower or mixing truck with side discharge — or by hydraulic seeding after berm construction.

**WEIGHTED SEDIMENT FILTER TUBE - Sediment Removal Efficiency: MODERATE. This device is an ABACT for HQ but not EV watersheds.** Weighted sediment filter tubes are tube-shaped devices filled with non-biodegradable filter materials for longevity and reuse. They may be used to control runoff from small disturbed areas where silt fence would normally be used as well as certain locations where a silt fence is not typically effective (e.g. above headwalls and endwalls). In general, the maximum slope length for standard silt fence may be used for 12” diameter tubes and slope lengths for reinforced silt fence (Table 4.4 or Figure 4.3) may be used for 18” to 20” diameter tubes. However, longer slope lengths may be considered by the Department on a case-by-case basis. The tubes can also be used instead of rock filters or as filters for storm sewer inlets located in sump areas. Standard Construction Details # 4-3 through # 4-5 may be used for weighted sediment filter tubes installation and maintenance. When the area tributary to a tube has been stabilized, an undamaged tube may be removed and used at another location.

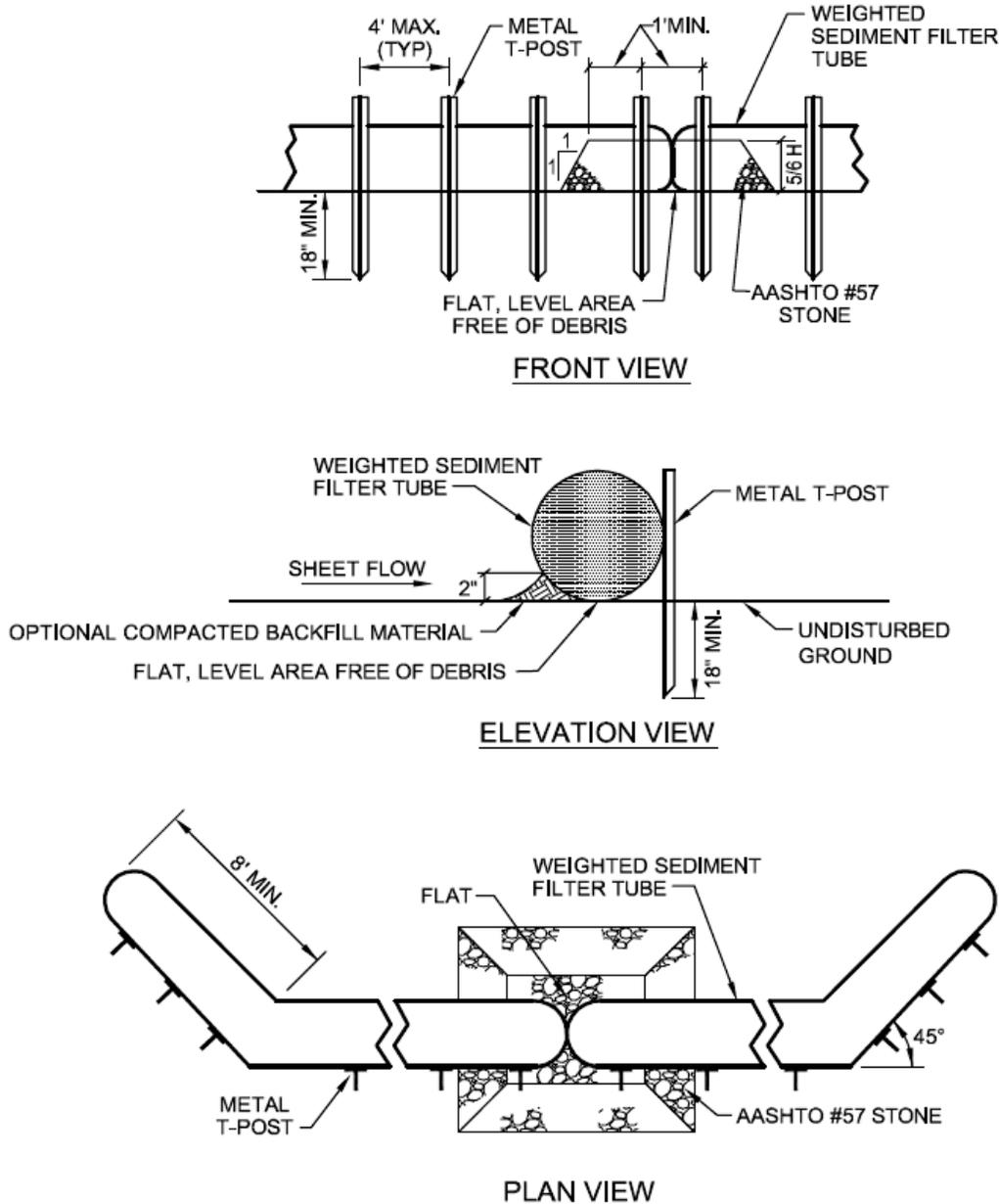


ACF

Weighted sediment filter tubes may be placed in areas of concentrated flow in lieu of rock filters if installed according to manufacturer’s recommendations or Standard Construction Detail # 4-4. Weighted sediment filter tubes may not be used in lieu of protective liners in constructed channels.

Where flow path widths exceed the length of one filter tube, Standard Construction Detail # 4-5 should be used.

**STANDARD CONSTRUCTION DETAIL # 4-3  
Weighted Sediment Filter Tube Installation**



Adapted from PA Turnpike Commission

Sediment tube placement area shall be prepared so that it is free of all debris, including rocks, sticks, roots, etc. A 2" layer of AASHTO #57 stone shall be placed where the logs come together. Ends of tubes may be overlapped according to manufacturer's specifications instead of the AASHTO #57 stone.

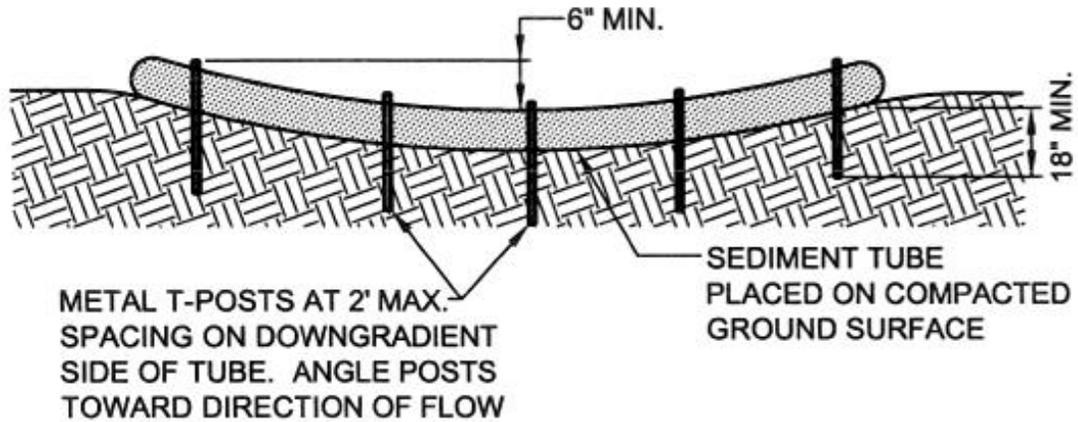
Sediment tubes shall be placed at existing level grade. Ends shall be extended upslope at 45° to the main filter log alignment for a minimum of 8 feet (Figure 4.1).

Sediment tubes shall be inspected weekly and after each runoff event.

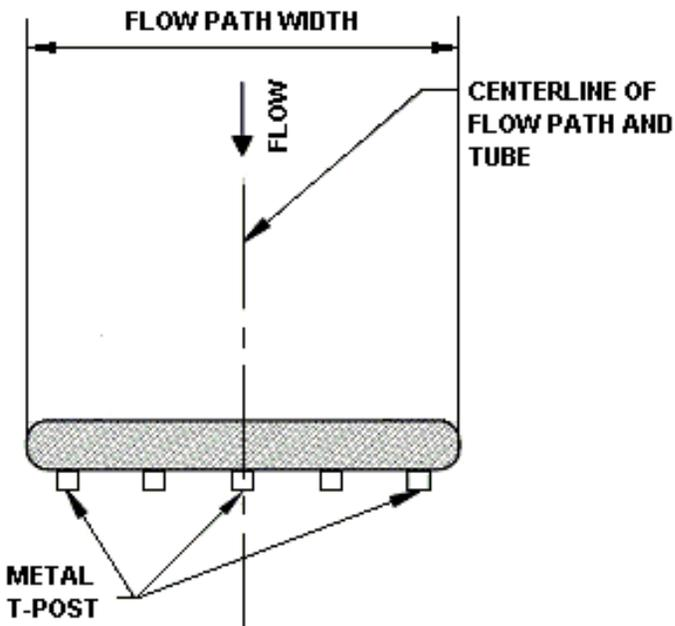
Sediment deposits shall be cleaned from the log when it reaches half the height of the tube.

Damaged tubes shall be replaced within 24 hours of inspection. A supply of tubes shall be maintained on site for this purpose.

**STANDARD CONSTRUCTION DETAIL # 4-4**  
**Weighted Sediment Filter Tube Installation in a Concentrated Flow Area**



**FRONT VIEW**



Adapted from ACF

**PLAN VIEW**

**NOTE:** This detail applicable to flow paths with widths  $\leq$  one tube length.

Metal T-posts shall be installed at the center and at each end of the tube. Additional T-posts shall be installed as needed to meet the maximum 2-foot spacing.

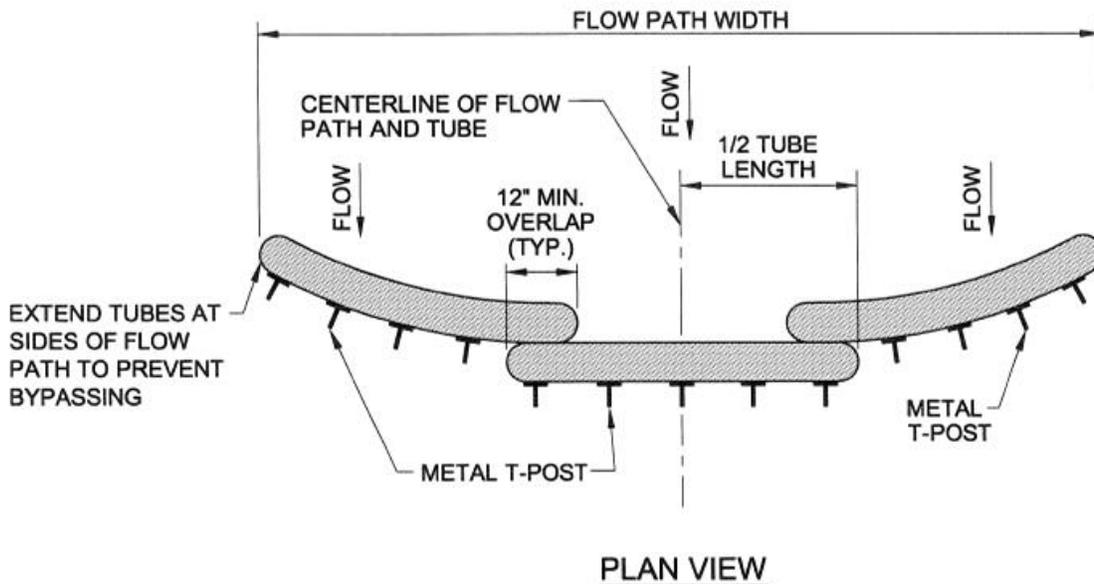
Sediment tubes shall be inspected weekly and after each runoff event.

Accumulated sediment shall be removed when it reaches half the height of the tube and disposed as directed elsewhere in the E&S plan.

Damaged tubes shall be repaired or replaced within 24 hours of inspection. A supply of tubes shall be kept on site for this purpose.

## STANDARD CONSTRUCTION DETAIL # 4-5 Weighted Sediment Filter Tube Installation Across a Wide Flow Path

NOTE:  
SLIGHTLY ANGLE STAKES WITH TOP  
FACING TOWARDS DIRECTION OF FLOW.



Adapted from ACF

**Metal T-posts shall be installed at the center and at each end of the tube. Additional T-posts shall be installed as needed to meet the maximum 2-foot spacing.**

**Sediment tubes shall be inspected weekly and after each runoff event.**

**Accumulated sediment shall be removed when it reaches half the height of the tube and disposed as directed elsewhere in the E&S plan.**

**Damaged tubes shall be repaired or replaced within 24 hours of inspection. A supply of tubes shall be kept on site for this purpose.**

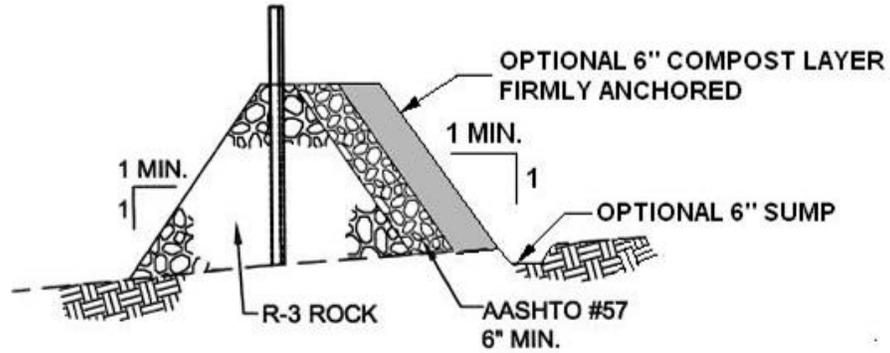
**ROCK FILTER OUTLET - Sediment Removal Efficiency: LOW. This device is not an ABACT for special protection watersheds.** Rock filter outlets may be used to address problems of concentrated flows to sediment barriers. Wherever a sediment barrier has failed due to an unanticipated concentrated flow, a rock filter outlet should be installed unless that concentrated flow can be otherwise directed away from the barrier.



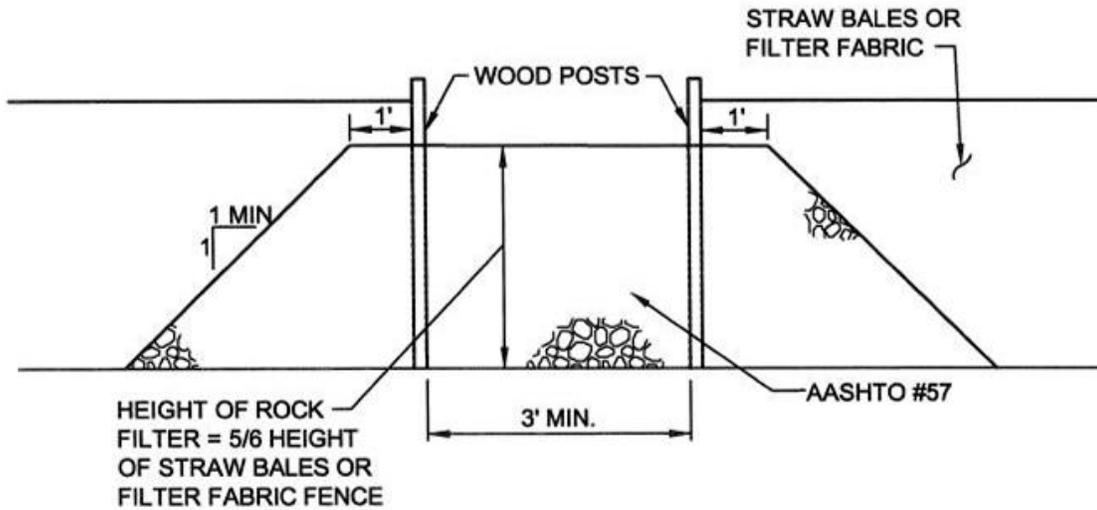
Westmoreland Conservation District

In special protection watersheds — HQ or EV — or where additional water filtering is desired, a 6 inch layer of compost should be added and anchored on top of the upslope side of the AASHTO #57 stone. A 6-inch deep sump may be installed immediately upslope of the rock filter outlet to provide additional sediment removal capacity.

**STANDARD CONSTRUCTION DETAIL # 4-6  
Rock Filter Outlet**



**OUTLET CROSS-SECTION**



**UP-SLOPE FACE**

PA DEP

A rock filter outlet shall be installed where failure of a silt fence or straw bale barrier has occurred due to concentrated flow. Anchored compost layer shall be used on upslope face in HQ and EV watersheds.

Sediment shall be removed when accumulations reach 1/3 the height of the outlet.



**SILT FENCE (FILTER FABRIC FENCE) - Sediment Removal Efficiency: LOW.** This device is not an ABACT for special protection watersheds. However, it may be used to increase the efficiency of another BMP which is an ABACT (e.g. vegetated filter strip). Silt fence may be used to control runoff from small disturbed areas when it is in the form of sheet flow, and the discharge is to a stable area. Only those fabric types specified for such use by the manufacturer should be used. In order to provide sufficient fabric for proper anchoring of the fence, standard filter fabric width should be 30" min.; reinforced and super filter fabric width should be 42" min.

York County Conservation District

Do not use silt fence in areas of concentrated flows (e.g. channels, swales, erosion gullies, across pipe outfalls, as inlet protection, etc.). **Filter fabric should not be wrapped around the principal spillway risers of sediment basins or traps.**

Silt fence should not be used in areas where rock or rocky soils prevent the full and uniform anchoring of the fence. Forested areas are not recommended unless tree roots can be severed during excavation of the anchor trench.

At a minimum, the fabric should have the properties shown in Table 4.3:

**TABLE 4.3  
Fabric Properties for Silt Fence**

<b>Fabric Property</b>	<b>Minimum Acceptable Value</b>	<b>Test Method</b>
Grab Tensile Strength (lb)	120	ASTM D1682
Elongation at Failure (%)	20% Max.	ASTM D1682
Mullen Burst Strength (psi)	200	ASTM D 3786
Trapezoidal Tear Strength (lb)	50	
Puncture Strength (lb)	40	ASTM D 751 (modified)
Slurry Flow Rate (gal/min/sf)	0.3	ASTM 5141
Equivalent Opening Size	30	US Std. Sieve CW-02215
Ultraviolet Radiation Stability (%)	80	ASTM G-26

Adapted from New York DEC and PennDOT Pub 408

Silt fence should not be installed on uncompacted fills or in extremely loose soils (e.g. sandy loam), since this will likely result in undermining of the fence.

Silt fence should be installed at existing level grade. Both ends of each fence section should be extended at least 8 feet upslope across undisturbed ground at 45 degrees to the main fence alignment to allow for pooling of water.

A 6" deep trench should be excavated, minimizing the disturbance on the downslope side. The bottom of the trench should be at level grade. **NOTE:** Standard silt fence may be installed using the slicing

method provided manufacturer's recommendations are followed. Where this method is chosen, show all standard details and instructions provided by the manufacturer on the plan drawings.

Support stakes that are 2" X 2" ( $\pm 3/8$ ") hardwood (minimum cross-sectional area of 3.0 square inches) or equivalent steel (U or T weighing not less than 1.33 pound per linear foot) should be driven 18" below the existing ground surface at 8-foot (max.) intervals (see Standard Construction Detail # 4-7). The filter fabric should be stretched and fastened to the upslope side of the support stakes.

Wherever reinforced silt fence is installed, the reinforcement mesh should be fastened to the stakes prior to the fabric (Standard Construction Detail # 4-8).

At fabric ends, both ends should be wrapped around the support stake and stapled. If the fabric comes already attached to the stakes, the end stakes should be held together while the fabric is wrapped around the stakes at least one revolution (360 degrees) prior to driving the stakes.

The bottom of the fence should be anchored by placing the fabric in the bottom of the trench, then backfilling and compacting the fill material in the trench (an acceptable alternative is the use of a machine which slices the soil to a depth of at least 6 inches and inserts the fabric in a continuous operation.)

Guy wires should be attached to the support stakes of reinforced silt fence (Standard Construction Detail # 4-8). An acceptable alternative to the guy wires is to stake a continuous row of straw bales on the downslope side of the fence (Standard Construction Detail # 4-9).

Silt fence alignment should be at least 8' from the toe of fill slopes.

The maximum slope length — in both existing and final grade — above standard (18"), reinforced (30") or super silt fence should not exceed that shown in Table 4.4 or Figure 4.3. The slope length shown is the distance from the fence to the drainage divide or the nearest upslope channel. **NOTE: Slope length cannot be addressed by use of multiple rows of silt fence.**

**TABLE 4.4**  
**Maximum Slope Length for Silt Fence**

Slope - Percent	Maximum Slope Length (ft) Above Fence		
	Standard (18" High) Silt Fence	Reinforced (30" High) Silt Fence	Super Silt Fence
2 (or less)	150	500	1000
5	100	250	550
10	50	150	325
15	35	100	215
20	25	70	175
25	20	55	135
30	15	45	100
35	15	40	85
40	15	35	75
45	10	30	60
50	10	25	50

PA DEP

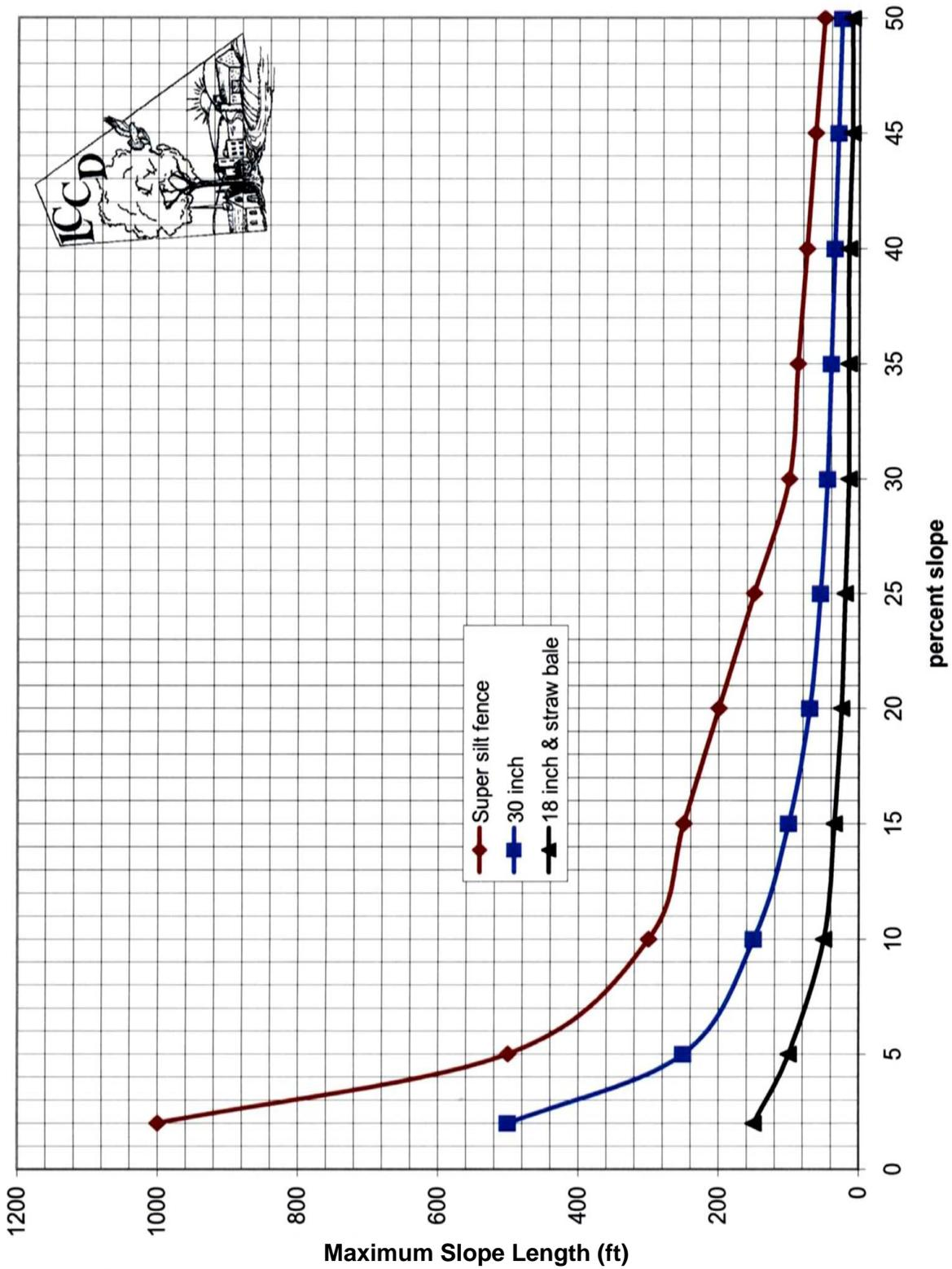


Wherever there is a break or change in slope above the silt fence, the maximum allowable slope length should be determined by the following method:

- (a) Determine the length and percent of the slope segment immediately above the fence.
- (b) Subtract the length of this segment from the allowable slope length for that percent slope shown in Table 4.4. If the result is positive, find the percentage of the allowable slope length that has been used (slope length  $\div$  allowable slope length).
- (c) Subtract the result from 1.00 to determine the unused percentage of allowable slope length.
- (d) Determine the maximum allowable slope length for the percent slope of the remaining segment from Table 4.4.
- (e) Multiply this allowable slope length by the remainder from step (c) above.
- (f) Add the slope length ( $L_1$ ) from step (a) to that from step (e). This is the maximum allowable slope length for the entire slope.

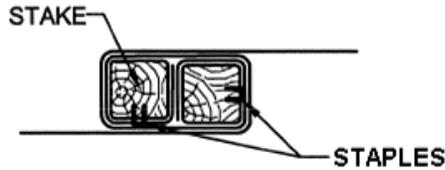
Silt fence should be inspected weekly and after each runoff event. Needed repairs should be initiated immediately after the inspection.

**FIGURE 4.3**  
**Maximum Permissible Slope Length above Silt Fence and Straw Bale Barriers**

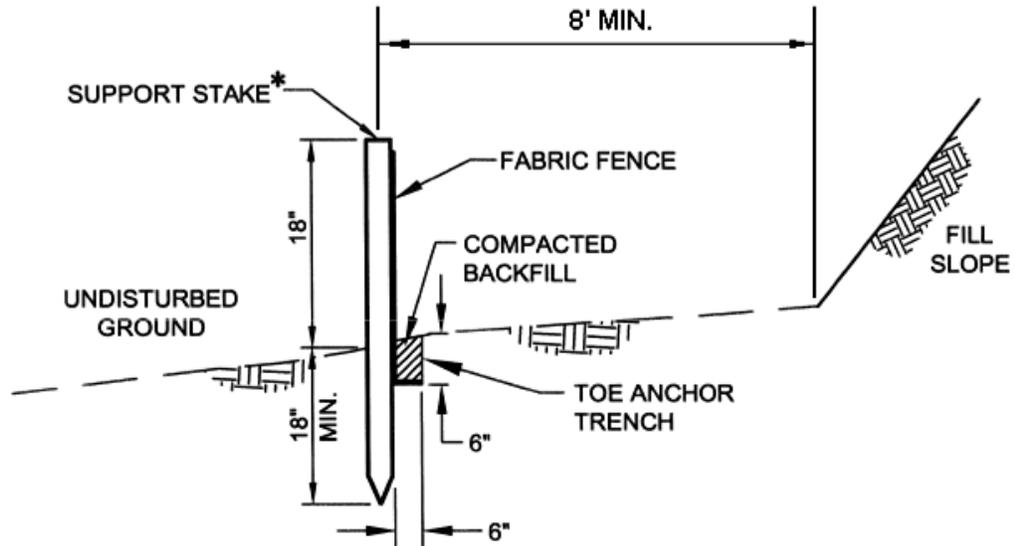


**STANDARD CONSTRUCTION DETAIL # 4-7  
Standard Silt Fence (18" High)**

\*STAKES SPACED @ 8' MAX.  
USE 2" x 2" (± 3/8") WOOD  
OR EQUIVALENT STEEL  
(U OR T) STAKES



JOINING FENCE SECTIONS



ELEVATION VIEW

PA DEP

Fabric shall have the minimum properties as shown in Table 4.3.

Fabric width shall be 30" minimum. Stakes shall be hardwood or equivalent steel (U or T) stakes.

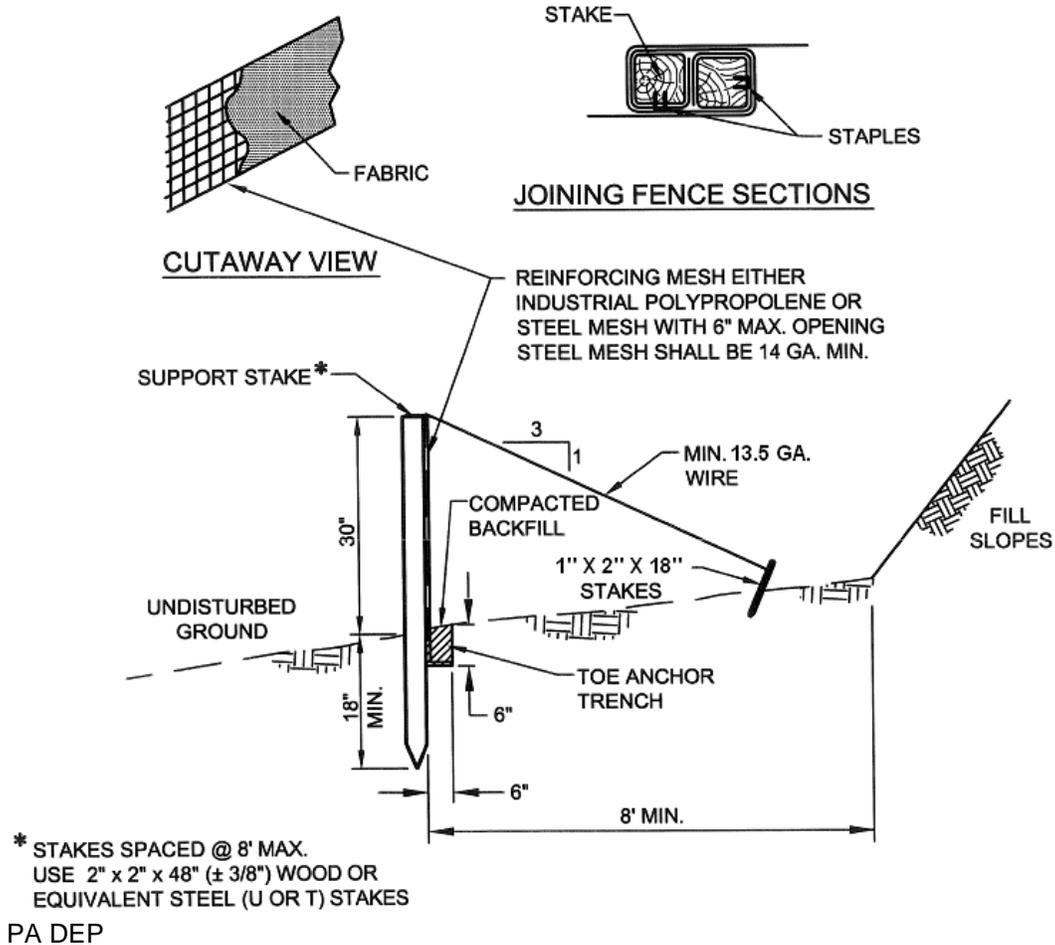
Silt fence shall be placed at level existing grade. Both ends of the fence shall be extended at least 8 feet up slope at 45 degrees to the main fence alignment (see Figure 4.1).

Sediment shall be removed when accumulations reach half the aboveground height of the fence.

Any section of silt fence which has been undermined or topped shall be immediately replaced with a rock filter outlet (Standard Construction Detail # 4-6).

Fence shall be removed and properly disposed of when tributary area is permanently stabilized.

**STANDARD CONSTRUCTION DETAIL # 4-8  
Reinforced Silt Fence (30" High)**



Fabric shall have the minimum properties as shown in Table 4.3.

Fabric width shall be 42" minimum. Stakes shall be hardwood or equivalent steel (U or T) stakes. An 18" support stake shall be driven 12" minimum into undisturbed ground.

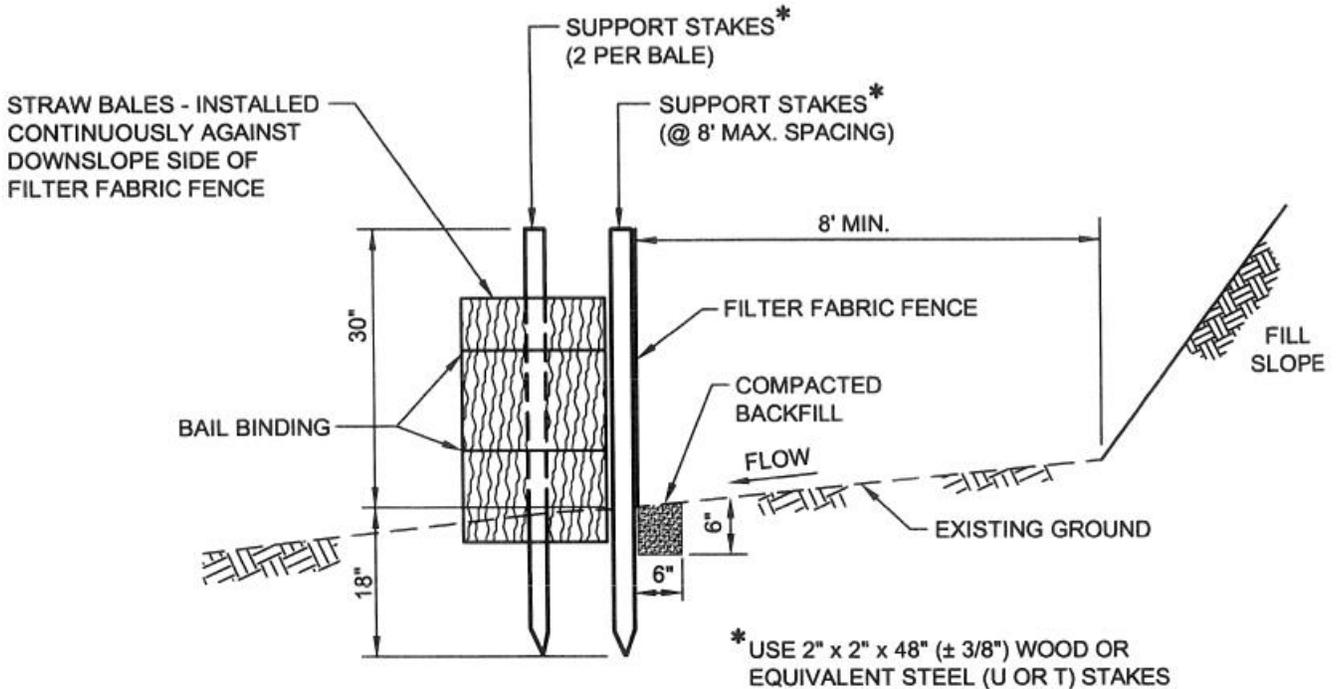
Silt fence shall be installed at existing level grade. Both ends of each fence section shall be extended at least 8 feet upslope at 45 degrees to the main fence alignment (Figure 4.1).

Sediment shall be removed where accumulations reach half the aboveground height of the fence.

Any section of silt fence which has been undermined or topped shall be immediately replaced with a rock filter outlet (Standard Construction Detail # 4-6).

Fence shall be removed and properly disposed of when tributary area is permanently stabilized.

## STANDARD CONSTRUCTION DETAIL # 4-9 Silt Fence Reinforced by Staked Straw Bales



PA DEP

Fabric shall have the minimum properties as shown in Table 4.3.

This BMP is not suitable for projects lasting longer than 3 months unless bales are replaced quarterly.

Fabric width shall be 42" minimum. Stakes shall be hardwood or equivalent steel (U or T) stakes.

Silt fence shall be installed at existing level grade. Both ends of each fence section shall be extended at least 8 feet upslope at 45 degrees to the main fence alignment (Figure 4.1).

Sediment shall be removed where accumulations reach half the aboveground height of the fence.

Any fence section which has been undermined or topped shall be immediately replaced with a rock filter outlet (Standard Construction Detail # 4-6).

Fence shall be removed and properly disposed of when tributary area is permanently stabilized.

SUPER SILT FENCE (SUPER FILTER FABRIC FENCE) - **Sediment Removal Efficiency: LOW.** This device is not an ABACT for special protection watersheds. However, it may be used with another BMP that is an ABACT (e.g. vegetated filter strip) to make it more effective. Super silt fence may be used to control runoff from some small disturbed areas where the maximum slope lengths for reinforced silt fence cannot be met and sufficient room for construction of sediment traps or basins does not exist.



PA DEP

Only those fabric types specified for use as silt fence by the manufacturer should be used.

The maximum slope length — in both existing and final grade — above any super silt fence should not exceed that shown in Table 4.4 or Figure 4.3. The slope length shown is the distance from the fence to the drainage divide or the nearest upslope channel. **NOTE: Slope length is not increased by use of multiple rows of super silt fence.**

Super silt fence should not be used in areas where rock or rocky soils prevent the full and uniform anchoring of the fence or proper installation of the fence posts. It should be used only where access exists or can be made for the construction equipment required to install and remove the chain link fencing (e.g. trencher and posthole drill).

Super silt fence should be installed at level grade. Both ends of each fence section should be extended at least 8 feet upslope at 45 degrees to the main fence alignment to allow for pooling of water (see Figure 4.1).

Super silt fence should be installed according to the details shown in Standard Construction Detail # 4-10.

An 8" deep trench should be excavated, minimizing the disturbance on the downslope side. The bottom of the trench should be at level grade.

A chain link fence should be installed in the downslope side of the trench with the fence on the upslope side of the support poles. Poles should be 2 ½" diameter galvanized or aluminum posts set at 10' maximum spacing. Poles should be installed a minimum 36" below the ground surface and extend a minimum of 33" aboveground. A posthole drill is necessary to do this for most sites. Poles do not need to be set in concrete. No. 7 gage tension wire should be installed horizontally through holes at top and bottom of chain-link fence or attached with hog rings at 5' (max.) centers.

Filter fabric should be stretched and securely fastened to the fence with wire fasteners, staples, or preformed clips. The fabric should extend a minimum of 33" above the ground surface.

At fabric ends, both ends should be overlapped a minimum of 6", folded, and secured to the fence (Standard Construction Detail # 4-10). The fabric toe should be placed in the bottom of the trench, backfilled, and compacted.



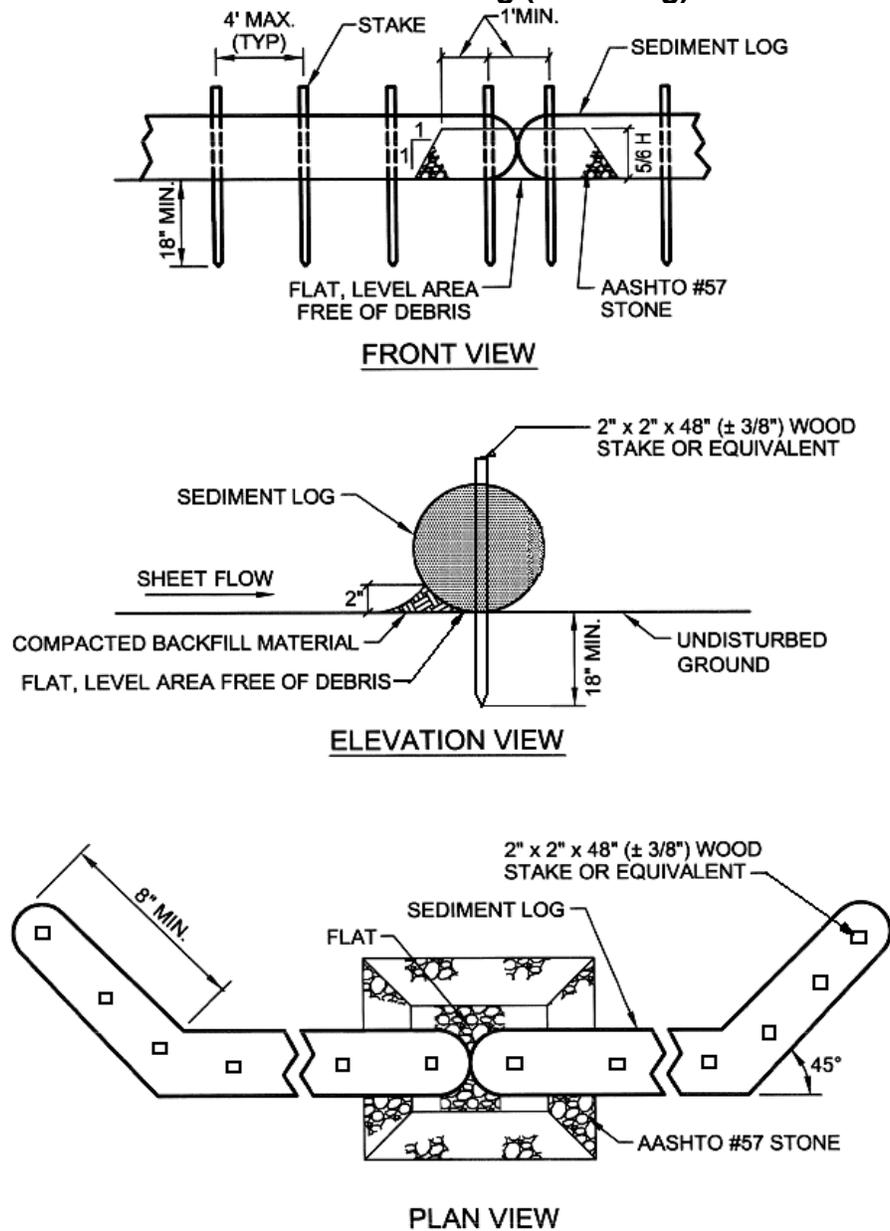


**SEDIMENT FILTER LOG (FIBER LOG) - Sediment Removal Efficiency: LOW. This device is not an ABACT for special protection watersheds. However, it may be used with other BMPs that are ABACT to increase their effectiveness.** Sediment filter logs are tube-shaped devices filled with straw, flax, rice, or coconut fiber and wrapped with UV-degradable polypropylene netting, burlap, jute, or coir for longevity. They may be used to control runoff from small disturbed areas where silt fence would normally be used as well as certain locations where silt fence is not typically effective (e.g. above headwalls and endwalls). In general, 9-inch diameter logs may be used on individual lots of  $\leq 0.5$  acres that are tributary to a sediment basin or sediment trap. Logs that are 12-inch may be used on slopes with lengths not exceeding those approved for standard silt fence (Table 4.4 or Figure 4.3). Logs that are 20-inch may be used on slopes approved for reinforce silt fence. However, longer slope lengths may be considered by the Department on a case-by-case basis. Standard Construction Detail # 4-11 should be used for sediment filter log installation and maintenance.



PA DEP

**STANDARD CONSTRUCTION DETAIL # 4-11  
Sediment Filter Log (Fiber Log)**



Adapted from PA Turnpike Commission

Sediment log placement area shall be prepared so that it is free of all debris, including rocks, sticks, roots, etc. A 2" layer of compacted fill material shall be placed on the upslope side of the log to prevent undercutting. Where more than one log is required to obtain specified length, logs shall be tightly abutted and securely staked (or overlapped by 12" min.). A layer of AASHTO #57 stone shall be placed where abutting logs come together (extending 2 ft. on both sides of the log). A 6" thick layer of compost on the upslope side may be substituted for the stone. Sediment filter logs shall be placed at existing level grade. Ends shall be extended upslope at 45° to the main filter log alignment for a minimum of 8 feet (Figure 4.1).

Sediment filter logs shall be inspected weekly and after each runoff event. Sediment deposits shall be cleaned from the log when it reaches half the height of the log. Damaged filter logs shall be replaced within 24 hours of inspection. A supply of filter logs shall be maintained on site for this purpose.

WOOD CHIP FILTER BERM - **Sediment Removal Efficiency: MODERATE. This device is an ABACT for HQ but not for EV watersheds.** Wood chip berms may be used on wooded or rocky slopes where staking and trenching of other BMPs is very difficult or impossible. Since they do not require trenching, wood chip filter berms disturb less soil during installation than silt fence or straw bale barriers. However, large obstructions such as tree limbs, boulders, etc. should be removed prior to placement of the wood chips. Once the tributary drainage area is permanently stabilized, the wood chip filter berm may either be leveled or left in place.



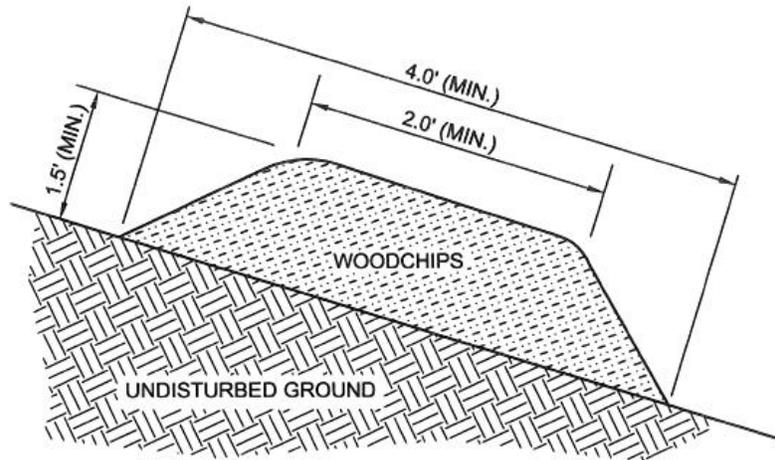
PA DEP

Wood chip filter berms should not be placed in areas of concentrated flow. They should be aligned parallel to existing contours and located below all disturbed areas. It is recommended that this BMP be used in conjunction with a vegetated filter strip as described later in this chapter. They are not recommended for use within 50 feet of a receiving surface water.

The maximum slope length above a wood chip filter berm should not exceed those in Table 4.5.

Wood chip filter berms should be constructed as shown in Standard Construction Detail # 4-12.

**STANDARD CONSTRUCTION DETAIL # 4-12  
Wood Chip Filter Berm**



Adapted from Lebanon County Conservation District

Prior to placement of the berm, obstructions such as tree limbs, large rocks, etc. shall be removed.

Wood chip filter berm shall be placed at existing level grade. Both ends of the berm shall be extended at least 8 feet up slope at 45 degrees to the main berm alignment (Figure 4.1). Wood chip berms shall not be located in areas of concentrated flow or used to construct sediment traps or other impoundments.

A 6" thick layer of compost shall be added to the upslope side of any wood chip filter berm located in an HQ watershed. This BMP shall not be routinely used in EV watersheds.

Berms shall be inspected weekly and after each runoff event. Sediment shall be removed when accumulations reach half the height of the berm. Damaged or deteriorated portions of the berm shall be replaced immediately upon inspection.

Berms may be leveled when the tributary area has been permanently stabilized or left in place.

**STRAW BALE BARRIER - Sediment Removal Efficiency: LOW. This device is not an ABACT for special protection watersheds.** Straw bale barriers may be used to control runoff from small disturbed areas provided that runoff is in the form of sheet flow. Since straw bales tend to deteriorate within a 3-month period, they should be considered as short-term control measures.



York County Conservation District

Straw bale barriers should not be used in areas of concentrated flows (e.g. channels, swales, erosion gullies, across pipe outfalls, as inlet protection, etc.) or in areas where they cannot be properly staked (e.g. paved areas).

The maximum slope length above any straw bale barrier should not exceed that shown in Table 4.5. The slope length shown is the distance from the barrier to the drainage divide or the nearest upslope channel. **NOTE: Slope length is not increased by use of multiple rows of straw bale barriers.** For non-uniform slopes use the method described following Table 4.4 to determine the slope length.

**TABLE 4.5**  
**Maximum Slope Length for Straw Bale Barriers and Wood Chip Filter Berms**

Slope - Percent	Maximum Slope Length (ft) Above Barrier
2 (or less)	150
5	100
10	50
15	35
20	25
25	20
30	15
35	15
40	15
45	10
50	10
> 50	Not Permitted

PA DEP

Straw bale barriers should not be used in areas where rock prevents full and uniform anchoring of the bales.

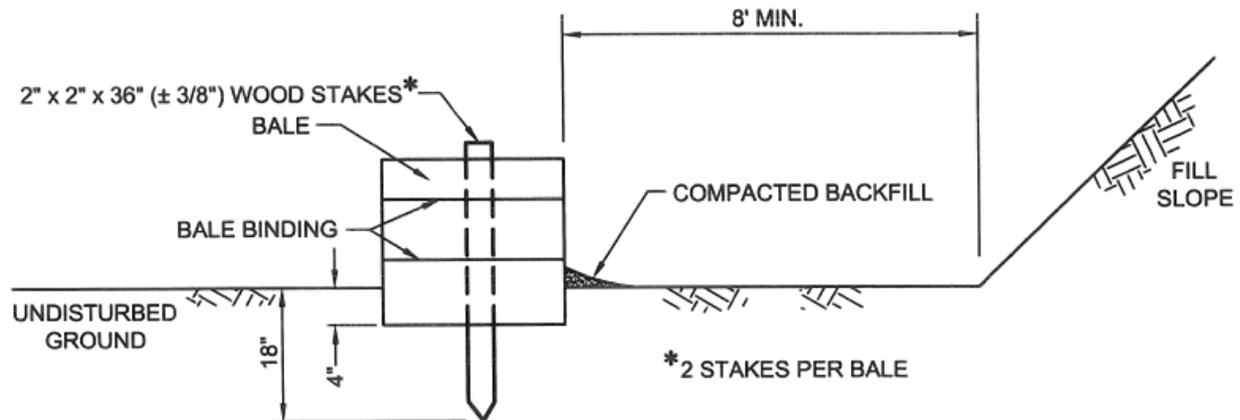
Straw bale barriers should be installed according to Standard Construction Detail # 4-13.

Bales should be installed in an anchoring trench. When improperly placed and installed (such as staking the bales directly to the ground with no soil seal or entrenchment), undercutting and other failures typically occur.

Two support stakes should be driven through each bale to a depth 18" below the ground surface.

The excavated soil should be backfilled and compacted on the upslope side of the bales.

### STANDARD CONSTRUCTION DETAIL # 4-13 Straw Bale Barrier



PA DEP

**Straw bale barriers shall not be used for projects extending more than 3 months.**

**Straw bale barriers shall be placed at existing level grade with ends tightly abutting the adjacent bales. First stake of each bale shall be angled toward adjacent bale to draw bales together. Stakes shall be driven flush with the top of the bale (see Figure 4.4). Both ends of the barrier shall be extended at least 8 feet up slope at 45 degrees to the main barrier alignment (see Figure 4.1).**

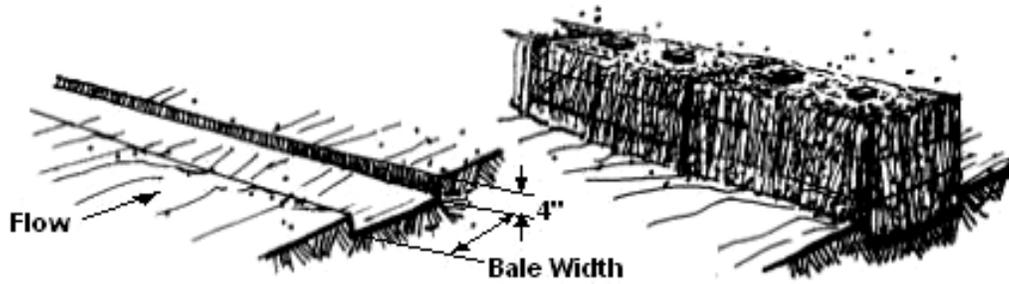
**Compacted backfill shall extend approximately 4 inches above ground level.**

**Sediment shall be removed when accumulations reach 1/3 the aboveground height of the barrier. Damaged or deteriorated bales shall be replaced immediately upon inspection.**

**Any section of straw bale barrier which has been undermined or topped shall be immediately replaced with a rock filter outlet (Standard Construction Detail # 4-6).**

**Bales shall be removed when the tributary area has been permanently stabilized.**

**FIGURE 4.4**  
**Straw Bale Barrier Installation**



**1. EXCAVATE THE TRENCH.**

**2. PLACE AND STAKE STRAW BALES**



**3. WEDGE LOOSE STRAW BETWEEN BALES**

**4. BACKFILL AND COMPACT THE LOOSE SOIL. (ANCHOR TOE)**

NRCS

**ROCK FILTER** - Sediment Removal Efficiency: **LOW**. This device is not an ABACT for special protection watersheds. However, the efficiency may be raised to moderate (ABACT for HQ watersheds) by anchoring a 6" layer of compost on the upgradient side. Rock filters may be used to control runoff within constructed channels — at the downstream end of the channel, during construction — until the protective lining is installed or during a temporary disturbance within the channel. They may also be used below construction work within an existing stream channel while flow is being diverted past the work area (Figures 3.9 through 3.11). In such cases, the filter should be located between the work area and the discharge from the bypass system.



York County Conservation District

Rock filters may not be used instead of appropriate channel linings. This practice often results in overtopping of the channel during storm events, scouring of the channel bottom below the filter, or erosion of the channel side slopes as sediment deposits build up behind the filter. Rock filters may not be used in roadside ditches instead of a suitable temporary protective liner until vegetation is established except at the inflows to ditch relief culverts on dirt or gravel roads or on temporary or permanent access roads.

Rock filters may not be used instead of an adequate protective lining in sediment basin emergency spillways. This can reduce the effective discharge capacity of the spillway and, in so doing, increase the possibility of embankment failure.

Rock filters should be constructed according to the specifications shown in Standard Construction Detail # 4-14.

Rock filters should be constructed with riprap sized as follows:

For channels with total depth > 3 feet, use R-4.

For channels with total depth between 2 and 3 feet, use R-3.

Rock filters should not be used in channels of less than 2 feet total depth.

The filter should be equal in height to **half** the total channel depth with a 6" depression in the center.



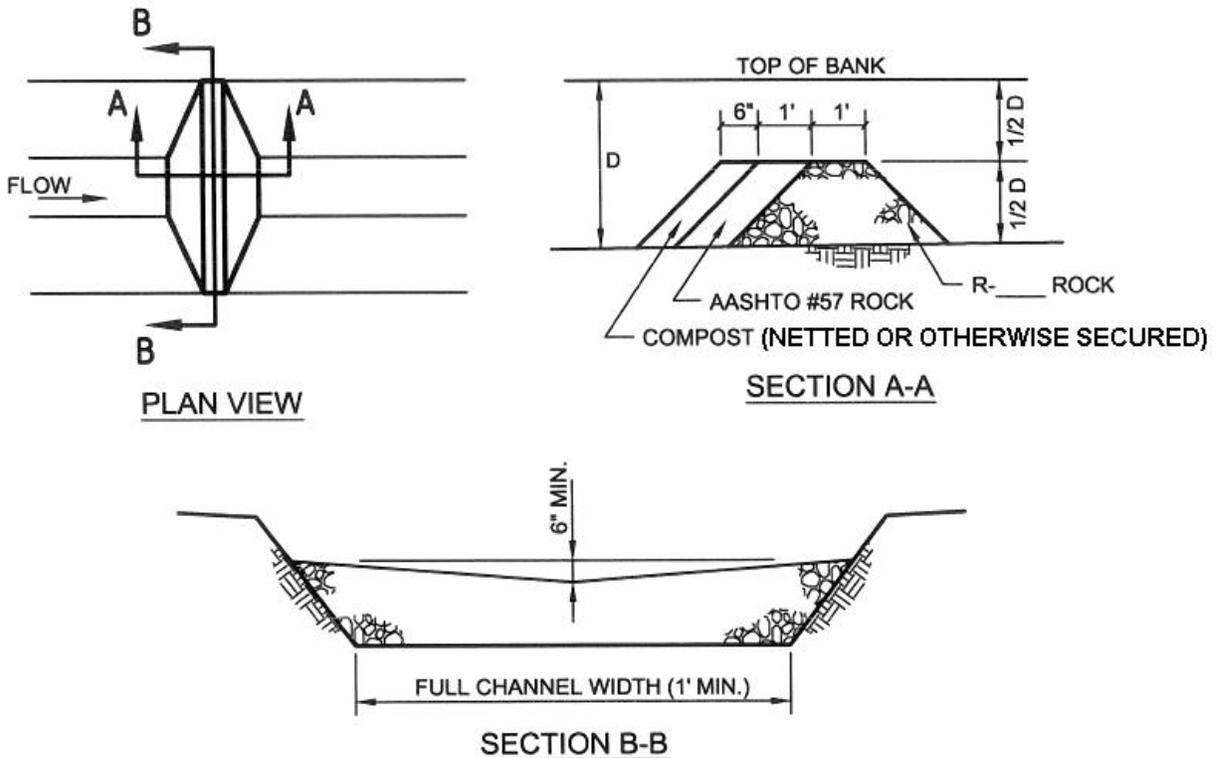
A one foot thick layer of AASHTO #57 (or smaller) stone should be placed on the upstream side of the filter. In special protection watersheds, a 6" layer of compost should be placed and anchored on top of the filter stone. NOTE: Filter fabric and straw bales should not be used in rock filters!

Rock filters should be inspected weekly and after each runoff event.

Clogged filter stone (AASHTO # 57) should be replaced.

Needed repairs should be initiated immediately after the inspection.

**STANDARD CONSTRUCTION DETAIL # 4-14  
Rock Filter**



PA DEP

FOR  $3' \leq D$  USE R-4  
 FOR  $2' \leq D < 3'$  USE R-3  
 NOT APPLICABLE FOR  $D < 2'$

**NOTE:** This table is intentionally blank and should be filled in by the plan preparer.

ROCK FILTER NO.	LOCATION	D (FT.)	RIPRAP SIZE

**Sediment shall be removed when accumulations reach 1/2 the height of the filter.**

**Immediately upon stabilization of each channel, installer shall remove accumulated sediment, remove rock filter, and stabilize disturbed areas.**

**VEGETATIVE FILTER STRIP - Sediment Removal Efficiency: MODERATE when used in series with another sediment removal BMP that does not result in a concentrated discharge onto the vegetative filter strip. This device, when used in this way, is an ABACT for HQ but not for EV watersheds.** A vegetative filter strip consists of a well-vegetated, grassy area below a disturbed area that can be used to remove sediment from runoff prior to its reaching surface waters.



Lebanon County Conservation District

To be effective, runoff should be in the form of sheet flow, and the vegetative cover should be established prior to the disturbance. Due to the time required to establish vegetation and the need to control runoff from the areas disturbed while constructing filter strips, constructed vegetative filter strips are not recommended. The suitability of natural vegetative filter strips should be either field verified by the Department or conservation district or documented by photo(s) submitted by the applicant prior to approval. Vegetative filter strips on neighboring properties should not be proposed unless permission to use that area as a vegetative filter strip has been obtained from the owner of the property along with an agreement to leave the filter strip area undisturbed for as long as it is needed. Where control of the filter strip cannot be assured throughout its intended use, a substitute BMP that will be installed should the filter strip no longer be available should be specified in the E&S Plan.

Vegetative filter strips may be used to remove sediment from project runoff that is directed to the strip as sheet flow. The minimum filter strip width should be determined from Table 4.6.

Vegetation should be an existing, well-established, perennial grass. Wooded and brushy areas are not acceptable for purposes of sediment removal.

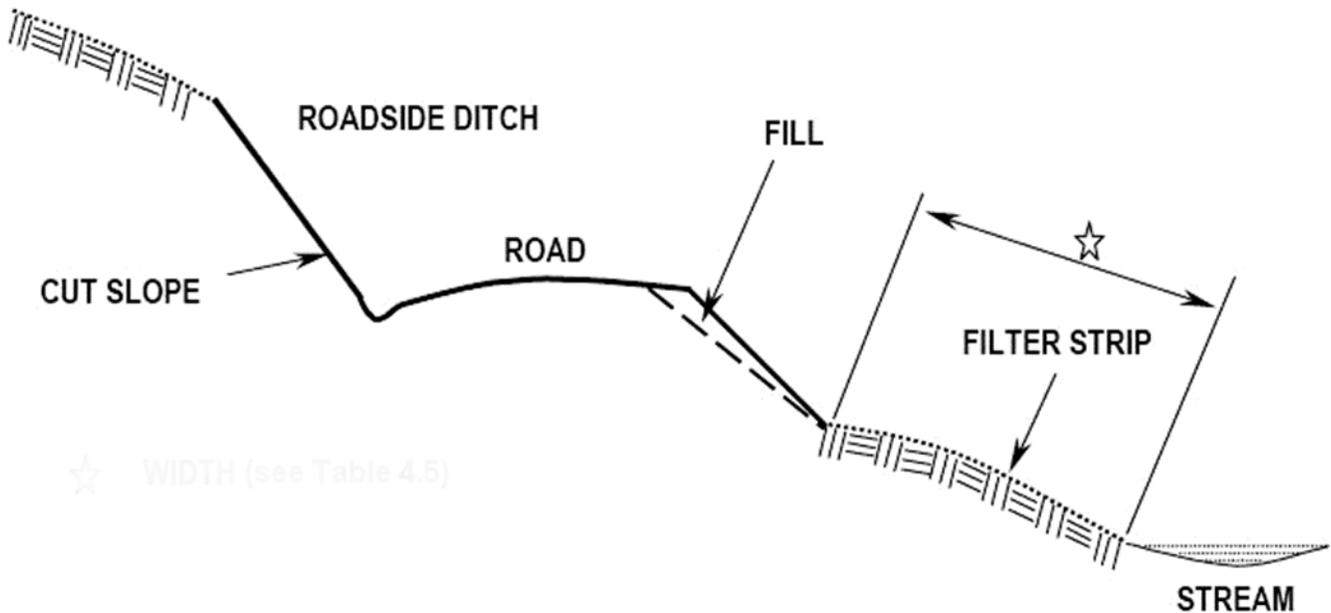
The total width of the filter strip should be at least half that of the disturbed area tributary to it. Minimum width of the filter strip should be:

$$W_{\min} = 2S + 25 \text{ ft (50 ft min. or } \frac{1}{2} \text{ that of the disturbed area tributary to it, whichever is longer)}$$

Where:  $W_{\min}$  = Minimum filter width in feet  
 $S$  = Average slope (in percent) of the filter strip

If at any time, the width of the vegetative filter strip has been reduced by sediment deposition to half its original width, suitable alternative BMPs should be installed immediately. The E&S Plan should specify what BMPs will be installed should this occur. Specifications, typical details, locations, etc. should be included.

**FIGURE 4.5  
 Vegetative Filter Strip**



PA DEP

**TABLE 4.6  
 Minimum Filter Strip Widths for Sediment Removal**

Land Slope (%)*	Minimum Filter Strip Width (ft.)
≤ 10	50
20	65
30	85
40	105
50	125
60	145
70	165

\* Land Slope is at location of filter strip.

Adapted from Professional Timber Harvesters Action Packet

## **STORM INLET PROTECTION**

Storm sewer inlets should be protected from sediment pollution wherever the sewer system does not discharge into a functioning sediment basin or sediment trap. (NOTE: Since detention ponds are not typically designed to effectively remove sediment prior to discharging, storm sewers discharging to detention ponds should be protected from sediment pollution.) Inlet protection may also be desirable in cases where it would be difficult or expensive to clean accumulated sediment from sewer lines, or where a temporary riser may have to be removed from a permanent basin prior to completion of all earthmoving. Inlet protection should be maintained (i.e. kept in good repair and free from straw, grass clippings, sediment, construction debris, litter, snow and ice) until all earthwork within the tributary drainage area has been completed and stabilized. To minimize potential clogging problems, consideration should be given to beehive grates for Type M inlets during construction. Inlet protection is not recommended for catch basins located near the edges of fill slopes, because clogging of the inlet could result in erosion of the fill slope. For these inlets, sediment removal BMPs should be provided at the discharge end of the system.

Silt fence and straw bale barriers are not effective when used in areas of concentrated flow as is common at storm sewer inlets. Typically, silt fence and straw bales fail, allowing unfiltered water to enter the inlet. In those rare instances where the silt fence or straw bales do not fail, runoff usually either bypasses the inlet, causing erosion and/or capacity problems down gradient, or backs up to the point of creating flooding. This can create traffic hazards for inlets located along active roadways.

**INLET FILTER BAG - Sediment Removal Efficiency: MODERATE. This device is an ABACT for HQ but not EV watersheds.** Filter bags should be capable of trapping all particles not passing a No.40 Sieve.



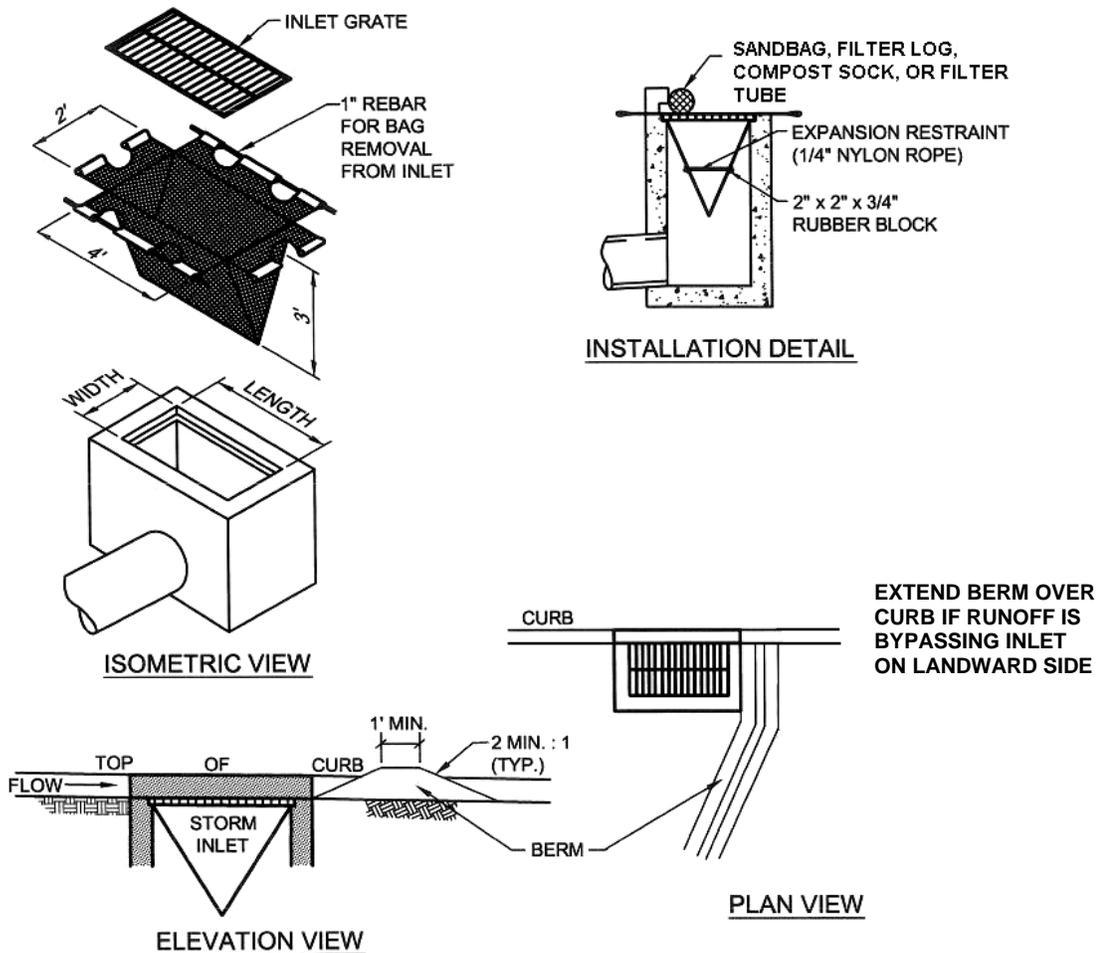
Northampton Conservation District

Wherever filter bags are used they should be installed according to the manufacturer's specifications. Typical installation details should be provided on the drawings. Standard Construction Details # 4-15 and # 4-16 are recommended. NOTE: Filter bags designed to fit over the inlet grate are not recommended for most storm sewer inlets. Use of such filter bags could result in a severe reduction of the inlet capacity resulting in flooding or runoff bypassing the inlet. Wherever such bags are used, they should be located at topographic low points and limited to ¼ acre maximum drainage areas. Inlet filter bags are not acceptable as the primary BMP to remove sediment from site runoff water.

Inlet filter bags should be inspected on a weekly basis and after each runoff event. Filter bags should be cleaned and/or replaced when the bag is half full or when flow capacity has been reduced so as to cause flooding or bypassing of the inlet. Accumulated sediment should be disposed in the approved manner. Bags that will be reused should be rinsed at a location where the rinse water will enter a sediment trap or sediment basin. Damaged filter bags should be replaced.

Needed repairs should be initiated immediately after the inspection.

**STANDARD CONSTRUCTION DETAIL # 4-15  
Filter Bag Inlet Protection - Type C Inlet**



Adapted from PennDOT RC-70, 2008 Edition

**Maximum drainage area = 1/2 acre.**

**Inlet protection shall not be required for inlet tributary to sediment basin or trap. Berms shall be required for all installations.**

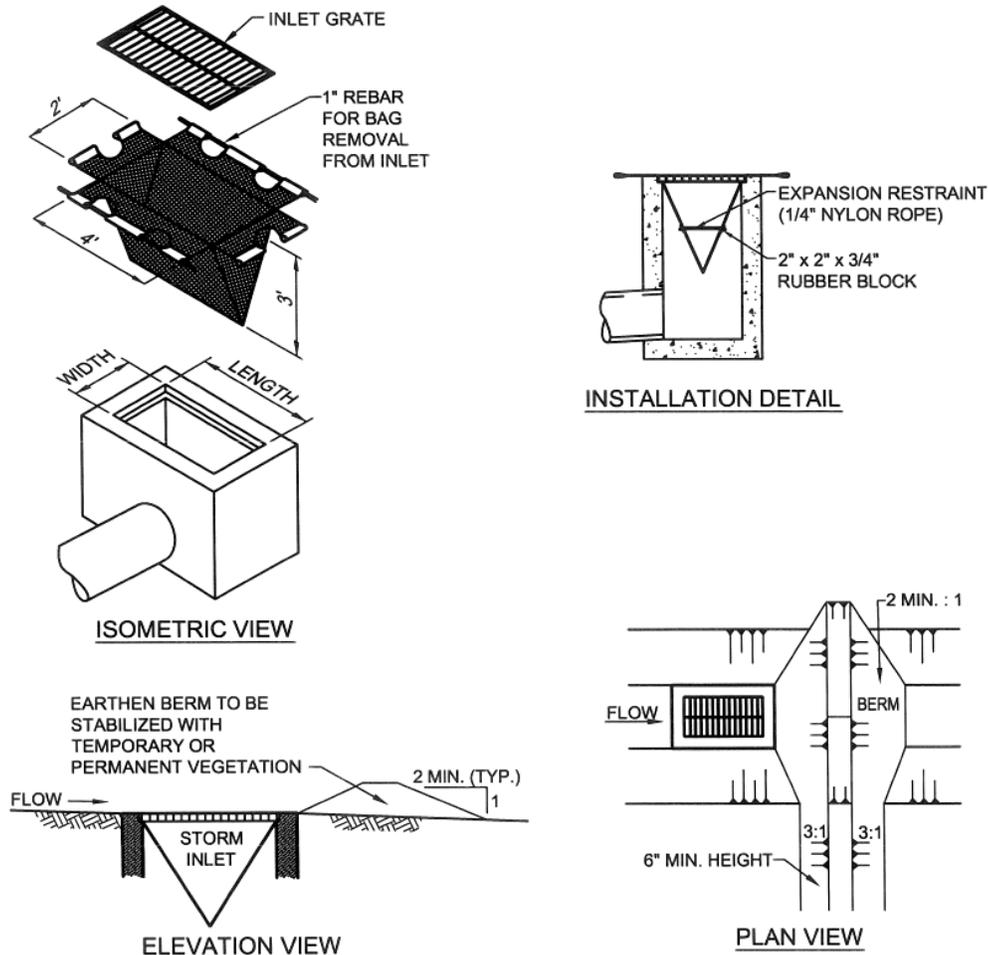
**Rolled earthen berm shall be maintained until roadway is stoned. Road subbase berm shall be maintained until roadway is paved. Six inch minimum height asphalt berm shall be maintained until roadway surface receives final coat.**

**At a minimum, the fabric shall have a minimum grab tensile strength of 120 lbs, a minimum burst strength of 200 psi, and a minimum trapezoidal tear strength of 50 lbs. Filter bags shall be capable of trapping all particles not passing a No. 40 Sieve.**

**Inlet filter bags shall be inspected on a weekly basis and after each runoff event. Bags shall be emptied and rinsed or replaced when half full or when flow capacity has been reduced so as to cause flooding or bypassing of the inlet. Damaged or clogged bags shall be replaced. A supply shall be maintained on site for replacement of bags. All needed repairs shall be initiated immediately after the inspection. Dispose of accumulated sediment as well as all used bags according to the plan notes.**

**DO NOT USE ON MAJOR PAVED ROADWAYS WHERE PONDING MAY CAUSE TRAFFIC HAZARDS.**

**STANDARD CONSTRUCTION DETAIL # 4-16  
Filter Bag Inlet Protection - Type M Inlet**



Adapted from PennDOT RC-70, 2008 Edition

**Maximum drainage area = 1/2 acre.**

**Inlet protection shall not be required for inlet tributary to sediment basin or trap. Berms shall be required for all installations.**

**Rolled earthen berm in roadway shall be maintained until roadway is stoned. Road subbase berm on roadway shall be maintained until roadway is paved. Earthen berm in channel shall be maintained until permanent stabilization is completed or remain permanently.**

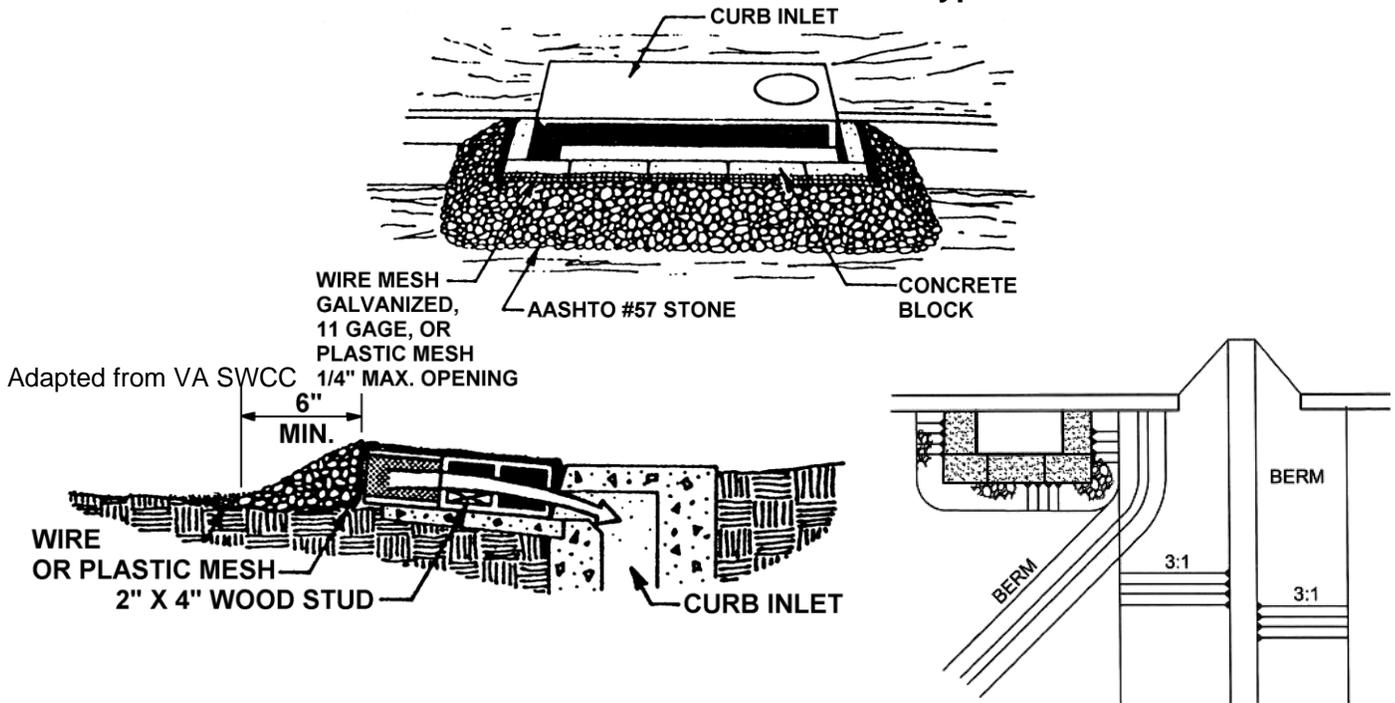
**At a minimum, the fabric shall have a minimum grab tensile strength of 120 lbs., a minimum burst strength of 200 psi, and a minimum trapezoidal tear strength of 50 lbs. Filter bags shall be capable of trapping all particles not passing a No. 40 sieve.**

**Inlet filter bags shall be inspected on a weekly basis and after each runoff event. Bags shall be emptied and rinsed or replaced when half full or when flow capacity has been reduced so as to cause flooding or bypassing of the inlet. Damaged or clogged bags shall be replaced. A supply shall be maintained on site for replacement of bags. All needed repairs shall be initiated immediately after the inspection. Dispose accumulated sediment as well as all used bags according to the plan notes.**

**DO NOT USE ON MAJOR PAVED ROADWAYS WHERE PONDING MAY CAUSE TRAFFIC HAZARDS.**

**STONE INLET PROTECTION - Sediment Removal Efficiency: LOW.** This device is not an ABACT for special protection watersheds. However, the efficiency may be raised to moderate (ABACT for HQ watersheds) by anchoring a 6" layer of compost around the outside of the stone. Wherever stone and concrete block inlet protection is proposed, it should be installed according to the details shown in Standard Construction Details # 4-17 or # 4-18. This type of inlet protection should not be used where ponding of water would cause a traffic hazard.

**STANDARD CONSTRUCTION DETAIL # 4-17  
Stone and Concrete Block Inlet Protection - Type C Inlet**



Maximum drainage area = 1 acre.

Inlet protection shall not be required for inlet tributary to sediment basin or trap. Berms shall be required for all installations.

Rolled earthen berm shall be provided and maintained immediately down gradient of the protected inlet until roadway is stoned. Road subbase berm shall be maintained until roadway is paved. Six inch minimum height asphalt berm shall be maintained until roadway surface receives final coat.

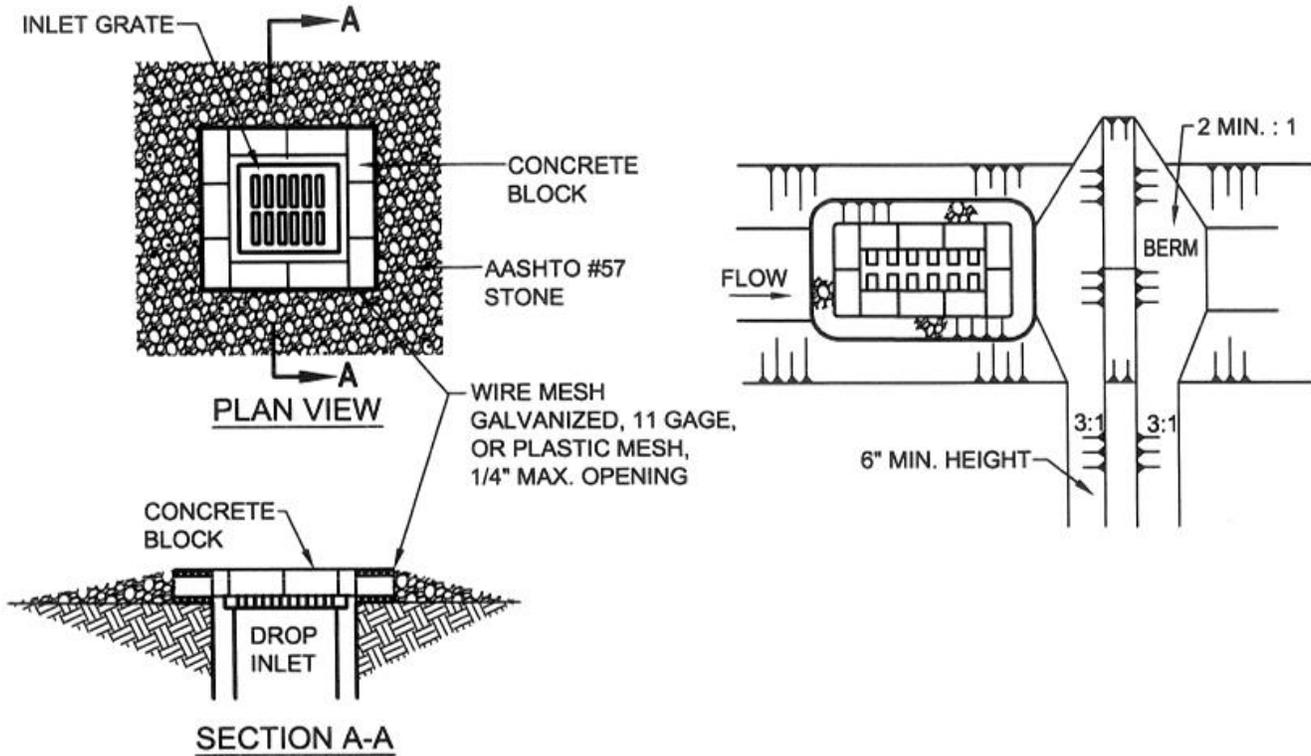
Sediment shall be removed when it reaches half the height of the stone. Damaged or clogged installations shall be repaired or replaced immediately.

For systems discharging to HQ or EV surface water, a 6 inch thick compost layer shall be securely anchored on outside and over top of stone.

**DO NOT USE ON MAJOR PAVED ROADWAYS WHERE PONDING MAY CAUSE TRAFFIC HAZARDS.**



**STANDARD CONSTRUCTION DETAIL # 4-18**  
**Stone and Concrete Block Inlet Protection - Type M Inlet**



Adapted from Maine DEP

**Maximum drainage area =1 acre.**

**Inlet protection shall not be required for inlet tributary to sediment basin or trap. Berms shall be required for all installations not located at a low point.**

**Rolled earthen berm in roadway shall be provided and maintained immediately down gradient of the protected inlet until roadway is stoned. Road subbase berm on roadway shall be maintained until roadway is paved. Earthen berm in channel shall be maintained until permanent stabilization is completed or to remain permanently.**

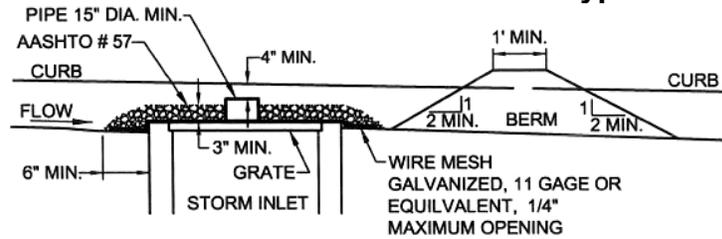
**Top of block shall be at least 6 inches below adjacent roads if ponded water would pose a safety hazard to traffic.**

**Sediment shall be removed when it reaches half the height of the stone. Damaged or clogged installations shall be repaired or replaced immediately.**

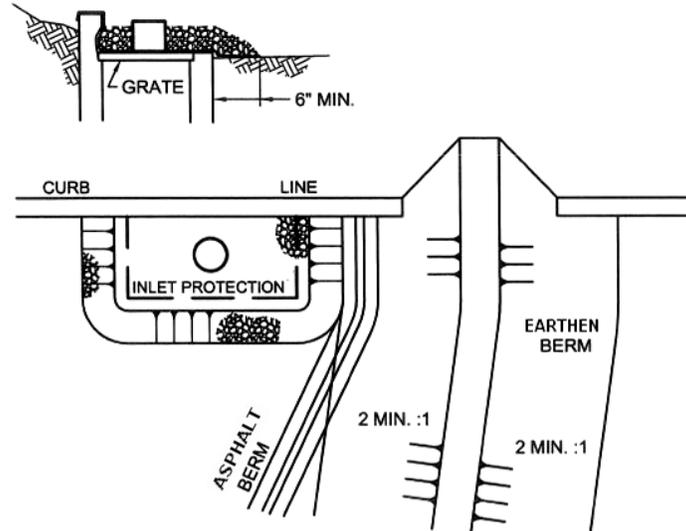
**For systems discharging to HQ or EV surface water, a 6 inch thick compost layer shall be securely anchored on outside and over top of stone. Compost shall meet the standards in Table 4.2.**

**STANDARD CONSTRUCTION DETAIL # 4-19**

## Stone Inlet Protection and Berm - Type C Inlet



ELEVATION VIEW



PA DEP

Inlet protection shall not be required for inlet tributary to sediment basin or trap. Berms shall be required for all installations.

Rolled earthen berm shall be provided and maintained immediately down gradient of the protected inlet until roadway is stoned. Road subbase berm shall be maintained until roadway is paved. A 6" minimum height asphalt berm shall be maintained until roadway surface receives final coat.

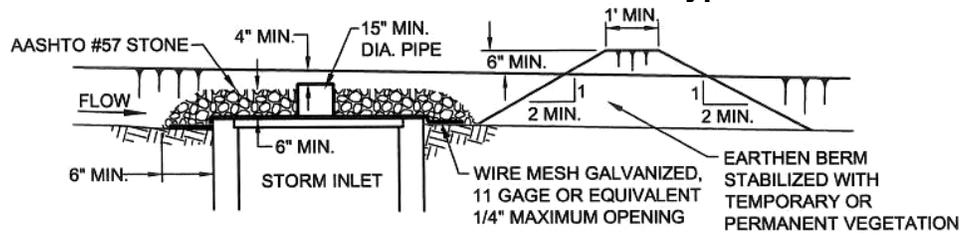
Stone inlet protection and berm for a Type C inlet can be used in one acre maximum drainage area with 15" overflow pipe and 4" head. A perforated plate welded to a metal riser may not be substituted for the wire mesh. A slotted plate welded to the riser may be used in conjunction with the wire mesh if calculations are provided to show sufficient capacity of the inlet to accept the peak runoff for a 2-year storm event from the tributary drainage area.

Sediment shall be removed when it reaches half the height of the stone. Damaged or clogged installations shall be repaired or replaced immediately.

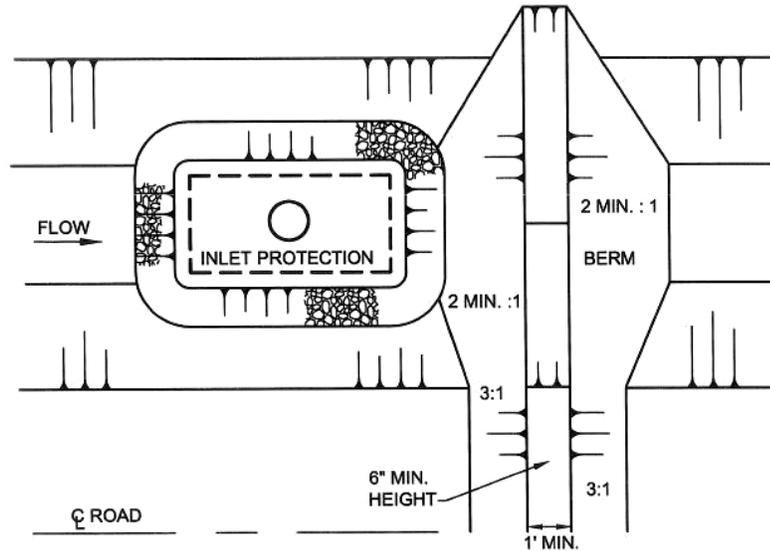
For systems discharging to HQ or EV surface water, a 6" thick compost layer shall be securely anchored on outside and over top of stone. Compost shall meet the standards in Table 4.2.

**DO NOT USE ON MAJOR PAVED ROADWAYS WHERE PONDING MAY CAUSE TRAFFIC HAZARDS.**

**STANDARD CONSTRUCTION DETAIL # 4-20  
Stone Inlet Protection and Berm - Type M Inlet**



ELEVATION VIEW



PLAN VIEW

PA DEP

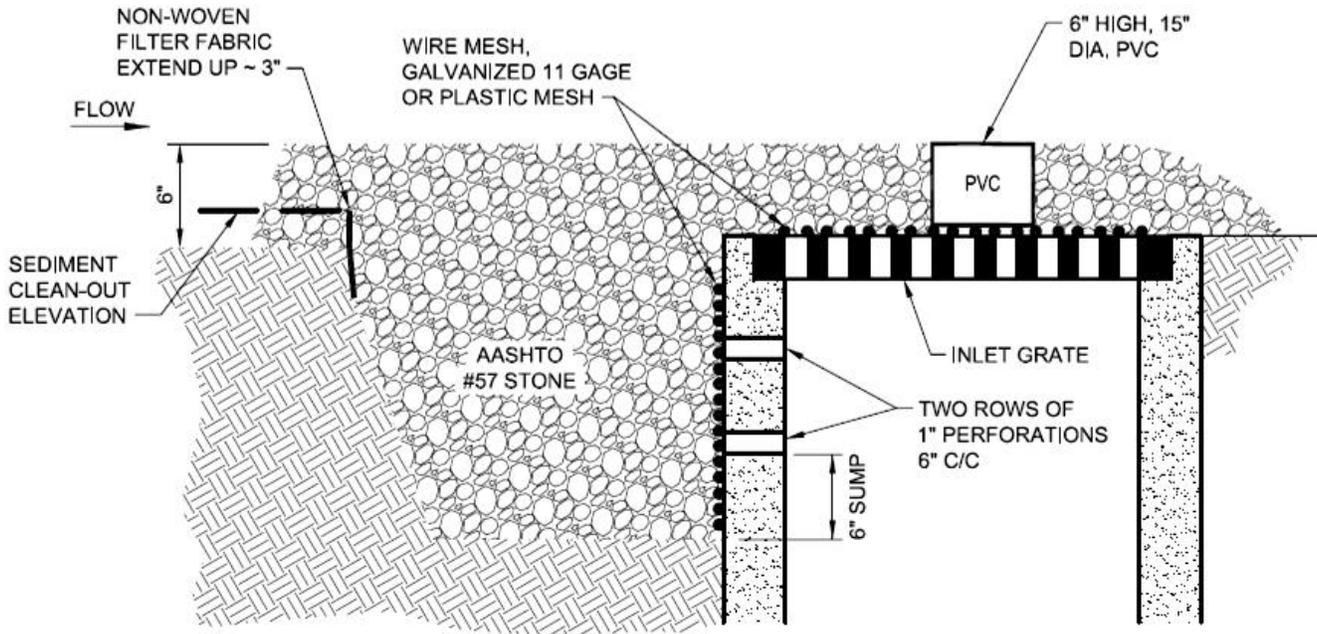
**Inlet protection shall not be required for inlet tributary to sediment basin or trap. Berms shall be required for all installations not located at a low point.**

**Rolled earthen berm in roadway shall be provided and maintained immediately down gradient of the protected inlet until roadway is stoned. Road subbase berm on roadway shall be maintained until roadway is paved. Earthen berm in channel shall be maintained until permanent stabilization is completed or to remain permanently**

**Stone inlet protection and berm for a Type M Inlet can be used in one acre maximum drainage area with 15" overflow pipe and 4" head. A perforated plate welded to a metal riser may not be substituted for the wire mesh. A slotted plate welded to the riser may be used in conjunction with the wire mesh if calculations are provided to show sufficient capacity of the inlet to accept the peak runoff for a 2-year storm event from the tributary drainage area. Top of pipe shall be at least 6 inches below adjacent roadway if ponded water would pose a safety hazard to traffic. Earthen berm shall be rolled.**

**Sediment shall be removed when it reaches half the height of the stone. Damaged or clogged installations shall be repaired or replaced immediately. For systems discharging to HQ or EV surface water, a 6 inch thick compost layer shall be securely anchored on outside and over top of stone. Compost shall meet the standards in Table 4.2.**

**STANDARD CONSTRUCTION DETAIL # 4-21**  
**Alternate Stone Inlet Protection for Type M Inlet - at Grade**



PA DEP

**Stone protection shall not be required for inlet tributary to sedimentation basins and sediment traps**

**Should include openings of ¼" maximum for wire or plastic mesh.**

**Holes may be drilled in concrete box.**

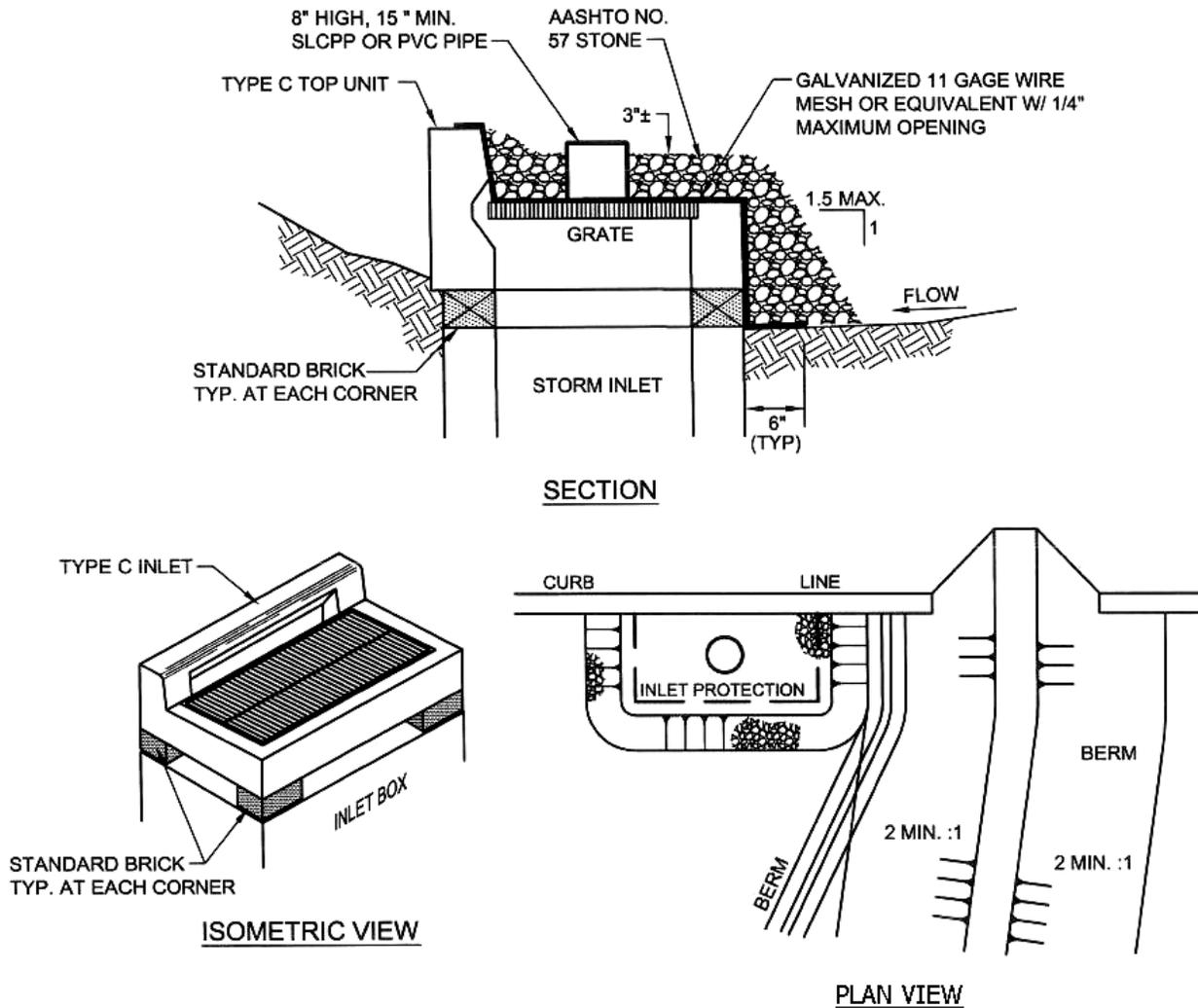
**Earthen berm in roadway shall not be required.**

**Alternate stone inlet protection for Type M inlet can be used on one acre maximum drainage area with 15" overflow pipe and 4" head.**

**Sediment shall be removed when it reaches half the height of the stone. Damaged or clogged installations shall be repaired or replaced immediately.**

**For systems discharging to HQ or EV surface water, a 6 inch thick compost layer shall be securely anchored on outside and over top of stone. Compost shall meet the standards in Table 4.2.**

**STANDARD CONSTRUCTION DETAIL # 4-22**  
**Alternate Type C Inlet Protection - Not at Grade**



PA DEP

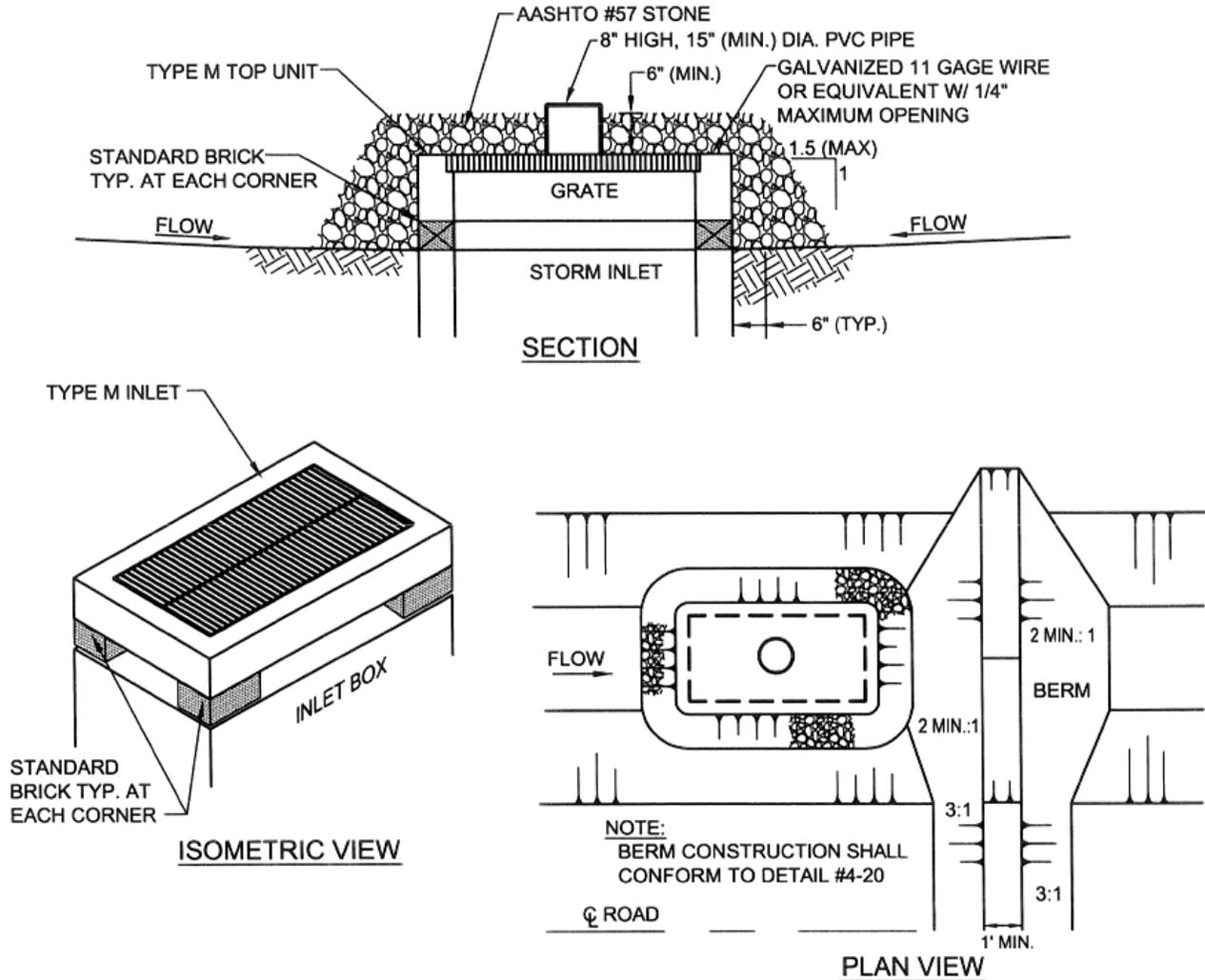
**Inlet protection shall not be required for inlets tributary to sediment basins or sediment traps. Alternate Type C inlet protection can be used on one acre maximum drainage area with 15" overflow pipe and 4" head.**

**Berms shall be required for all installations not located at low points. Earthen berms shall be stabilized with vegetation and maintained until roadway is stoned or tributary area is permanently vegetated. Road subbase berms shall be maintained until roadway is paved.**

**Inlets shall be inspected weekly and after each runoff event. Accumulated sediment shall be removed when it reaches half the height of the stone. Damaged installations shall be repaired or replaced within 24 hours of inspection.**

**For systems discharging to HQ or EV surface water, a 6 inch thick compost layer shall be securely anchored on outside and over top of stone. Compost shall meet the standards in Table 4.2.**

**STANDARD CONSTRUCTION DETAIL # 4-23**  
**Alternate Type M Inlet Protection - Not at Grade**



PA DEP

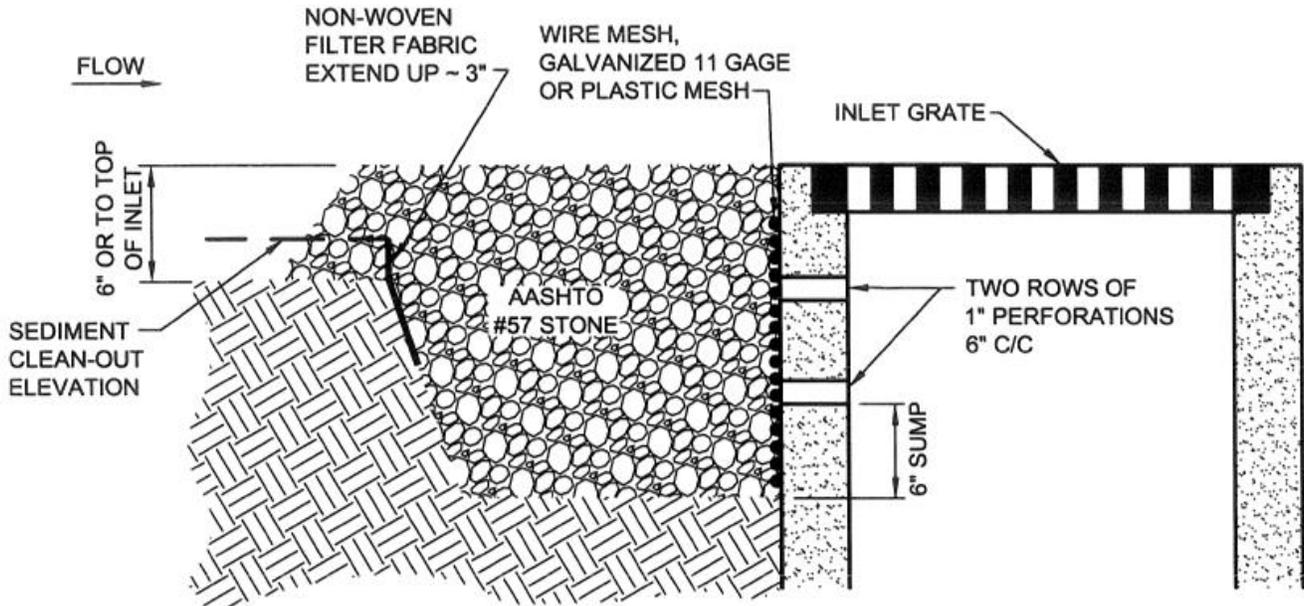
Inlet protection shall not be required for inlets tributary to sediment basins or sediment traps. Alternate Type M inlet protection can be used on one acre maximum drainage area with 15" overflow pipe and 4" head.

Berms shall be required for all installations not located at low points. Earthen berms shall be stabilized with vegetation and maintained until roadway is stoned or tributary area is permanently vegetated. Road subbase berms shall be maintained until roadway is paved.

Inlets shall be inspected weekly and after each runoff event. Accumulated sediment shall be removed when it reaches half the height of the stone. Damaged installations shall be repaired or replaced within 24 hours of inspection.

For systems discharging to HQ or EV surface water, a 6 inch thick compost layer shall be securely anchored on outside and over top of stone. Compost shall meet the standards in Table 4.2.

**STANDARD CONSTRUCTION DETAIL # 4-24**  
**Alternate Stone Inlet Protection - Type M Inlet Above Grade**



PA DEP

**Maximum drainage area =1 acre.**

**Inlet protection shall not be required for inlet tributary to sediment basin or trap. Berms shall be required for all installations not located at a low point.**

**Should contain openings  $\frac{1}{4}$ \"**

**Holes may be drilled in concrete box.**

**Earthen berm in roadway is not required.**

**Sediment shall be removed when it reaches half the height of the stone. Damaged or clogged installations shall be repaired or replaced immediately.**

**For systems discharging to HQ or EV surface water, a 6 inch thick compost layer shall be securely anchored on outside and over top of stone. Compost shall meet the standards in Table 4.2.**

## CHAPTER 5 - RUNOFF CALCULATIONS

Numerous methods are available to determine required channel capacity. Two methods, the SCS (now NRCS) Technical Release 55 - Urban Hydrology for Small Watersheds and the Rational Equation are mentioned in this handbook because of their popularity and simplicity. Other methods are also acceptable.

SCS TR-55 Urban Hydrology for Small Watersheds - Technical Release 55 (TR-55) presents simplified procedures to calculate stormwater runoff volume, peak rate of discharge, hydrographs, and storage volumes required for floodwater reservoirs. These procedures are applicable in small watersheds (2,000 acres or less), especially urbanizing watersheds, in the United States. Limits: NRCS type distributions, 24-hour duration rainfall, 10 subwatersheds maximum, minimum 0.1 hour and maximum 10-hour time of concentration.

Designers are referred to <http://www.hydrocad.net/tr-55.htm> to download the text version or the computer version of TR-55.

Updated rainfall data may be obtained from the National Weather Service's website [http://hdsc.nws.noaa.gov/hdsc/pfds/orb/pa\\_pfds.html](http://hdsc.nws.noaa.gov/hdsc/pfds/orb/pa_pfds.html) either by clicking the location of the site on the website map or by entering the site's latitude and longitude. Data from this website were used to develop Table 5.1. **(Note: Table 5.1 is useful for obtaining a quick initial estimate of rainfall data. However, since these data are not updated, they may not be used for the final design of PCSM BMPs, nor may they be used to determine rainfall intensity "I" for the rational equation.)**

Due to the irregular topography, the maximum sheet flow length to be used for unpaved areas in Pennsylvania is 150 feet with a most likely maximum length of 50-100 feet. The theoretical maximum length of 300 feet is achieved only in unique situations such as uniformly sloped paved parking lots. The maximum flow path length (L) for any disturbed area is 50 feet. It is unlikely that any sheet flow occurs in areas where active earthmoving is taking place, as well as previously disturbed areas that were not restored to approximate original contour. Therefore, the sheet flow equation should not be used for newly graded fill or cut slopes. Runoff from these areas should be considered shallow concentrated flow.

Whenever TR-55 is used to calculate runoff, Worksheets 2, 3, and 4 from TR-55 should be completed and included in the narrative portion of the plan submittal. If computer programs are used which do not provide printouts of these worksheets, the program used as well as the input data should be provided along with the output pages.

Weather Bureau Technical Paper 40. U.S. Department of Commerce, Hershfield, D.M. - Rainfall frequency atlas of the United States for durations from 30 minutes to 24 hours and return periods from 1 to 100 years. T.P. 40 is out of print. However, it is the basis for the maps in TR-55 described above.



**TABLE 5.1**  
**Pennsylvania Rainfall by County**  
**(For Use with Technical Release 55 - Urban Hydrology for Small Watersheds)**  
**NOT TO BE USED WITH THE RATIONAL EQUATION**

COUNTY	24 HR RAINFALL FOR VARIOUS FREQUENCIES							COUNTY	24 HR RAINFALL FOR VARIOUS FREQUENCIES						
	1 yr.	2 yr.	5 yr.	10 yr.	25 yr.	50 yr.	100 yr.		1 yr.	2 yr.	5 yr.	10 yr.	25 yr.	50 yr.	100 yr.
Adams	2.52	3.02	3.77	4.43	5.48	6.45	7.59	Lackawanna	2.12	2.55	3.15	3.69	4.55	5.35	6.30
Allegheny	1.97	2.35	2.88	3.30	3.90	4.40	4.92	Lancaster	2.51	3.02	3.85	4.56	5.63	6.56	7.59
Armstrong	2.03	2.42	2.95	3.40	4.01	4.53	5.06	Lawrence	1.99	2.37	2.90	3.33	3.94	4.44	4.96
Beaver	1.97	2.35	2.87	3.30	3.90	4.40	4.91	Lebanon	2.50	3.02	3.84	4.55	5.64	6.59	7.67
Bedford	2.19	2.62	3.27	3.81	4.60	5.27	5.99	Lehigh	2.69	3.24	4.05	4.73	5.75	6.63	7.60
Berks	2.65	3.19	4.00	4.68	5.67	6.50	7.41	Luzerne	2.37	2.84	3.53	4.13	5.08	5.96	6.99
Blair	2.23	2.68	3.33	3.87	4.63	5.28	5.96	Lycoming	2.38	2.85	3.53	4.12	5.04	5.88	6.87
Bradford	2.05	2.44	2.98	3.41	3.99	4.45	4.93	McKean	2.08	2.48	3.03	3.48	4.13	4.66	5.21
Bucks	2.71	3.26	4.10	4.80	5.81	6.67	7.59	Mercer	2.05	2.44	2.99	3.43	4.07	4.58	5.13
Butler	2.02	2.40	2.93	3.37	3.98	4.49	5.02	Mifflin	2.36	2.83	3.52	4.10	4.95	5.68	6.49
Cambria	2.17	2.59	3.18	3.68	4.39	4.97	5.59	Monroe	2.63	3.16	3.92	4.60	5.68	6.70	7.91
Cameron	2.11	2.53	3.10	3.60	4.35	5.02	5.80	Montgomery	2.67	3.21	4.03	4.70	5.68	6.50	7.38
Carbon	2.74	3.29	4.09	4.79	5.92	6.96	8.20	Montour	2.35	2.82	3.50	4.09	5.05	5.94	6.99
Centre	2.20	2.64	3.29	3.82	4.58	5.22	5.91	Northampton	2.64	3.16	3.95	4.61	5.60	6.45	7.41
Chester	2.70	3.25	4.07	4.75	5.73	6.55	7.44	Northumberland	2.32	2.78	3.45	4.04	4.96	5.82	6.83
Clarion	2.09	2.49	3.05	3.50	4.14	4.67	5.22	Perry	2.34	2.81	3.49	4.08	5.03	5.90	6.92
Clearfield	2.13	2.54	3.12	3.60	4.28	4.85	5.44	Philadelphia	2.72	3.28	4.12	4.83	5.85	6.72	7.68
Clinton	2.18	2.61	3.19	3.67	4.34	4.89	5.47	Pike	2.45	2.94	3.64	4.26	5.23	6.13	7.20
Columbia	2.38	2.85	3.54	4.14	5.10	5.99	7.04	Potter	2.01	2.40	2.96	3.44	4.21	4.91	5.74
Crawford	2.08	2.49	3.04	3.50	4.14	4.67	5.23	Schuylkill	2.77	3.33	4.14	4.85	5.96	6.97	8.17
Cumberland	2.35	2.82	3.50	4.11	5.08	5.97	7.02	Snyder	2.60	3.12	3.88	4.55	5.59	6.56	7.71
Dauphin	2.50	3.01	3.78	4.45	5.50	6.44	7.52	Somerset	2.06	2.46	3.08	3.61	4.44	5.16	5.97
Delaware	2.69	3.25	4.10	4.82	5.87	6.75	7.72	Sullivan	2.54	3.04	3.73	4.30	5.12	5.82	6.58
Elk	2.08	2.48	3.02	3.48	4.12	4.65	5.21	Susquehanna	2.23	2.67	3.26	3.74	4.41	4.96	5.55
Erie	2.13	2.56	3.19	3.71	4.46	5.09	5.76	Tioga	1.96	2.34	2.88	3.35	4.07	4.73	5.49
Fayette	2.08	2.47	3.02	3.46	4.08	4.60	5.13	Union	2.41	2.89	3.58	4.19	5.13	6.01	7.04
Forest	2.06	2.46	3.00	3.45	4.08	4.59	5.14	Venango	2.05	2.45	2.99	3.44	4.07	4.58	5.12
Franklin	2.44	2.94	3.65	4.26	5.17	5.97	6.86	Warren	2.07	2.47	3.01	3.47	4.11	4.63	5.19
Fulton	2.27	2.73	3.39	3.93	4.73	5.40	6.13	Washington	1.99	2.38	2.91	3.35	3.96	4.46	4.99
Greene	2.01	2.40	2.92	3.36	3.96	4.45	4.96	Wayne	2.38	2.86	3.53	4.12	5.03	5.86	6.83
Huntingdon	2.21	2.65	3.29	3.83	4.60	5.25	5.94	Westmoreland	2.05	2.45	2.99	3.43	4.06	4.57	5.11
Indiana	2.15	2.57	3.14	3.62	4.29	4.85	5.44	Wyoming	2.16	2.58	3.18	3.69	4.46	5.14	5.91
Jefferson	2.09	2.50	3.05	3.50	4.14	4.67	5.23	York	2.45	2.96	3.80	4.53	5.65	6.64	7.76
Juniata	2.36	2.83	3.52	4.11	5.02	5.84	6.79								

NWS - NOAA Atlas 14, Sept 25-29, 2008

**NOTE: Data from this table may not be used for final design of E&S or PCSM BMPs.**

THE RATIONAL EQUATION is a method for estimating **peak flow rates** in small watersheds (200 acres or less). This method uses or incorporates the following assumptions:

- (1) That rainfall occurs uniformly over the drainage area and that the design average rainfall intensity occurs over a period of time equal to the time of concentration of the drainage area.
- (2) That the drainage area's time of concentration is the travel time for water to flow from the furthestmost point (hydraulically) of the watershed to the downstream point of interest.
- (3) That the frequency of runoff equals the frequency of rainfall used in the equation:

$$Q = C I A$$

Where: Q = Peak runoff rate in cubic feet per second (cfs)  
C =  $C_w$  = Runoff coefficient (dimensionless)  
(See following steps for explanation of  $C_w$ )  
I = Rainfall intensity (inches/hour)\*  
A = Drainage area (acres)

**\* NOTE: DO NOT USE TABLE 5.1 TO DETERMINE RAINFALL INTENSITY "I" FOR THE RATIONAL EQUATION**

PROCEDURE (Use Standard E&S Worksheets 9 and 10 for organizing and documenting the parameters used):

Runoff Coefficient (C): Select an appropriate runoff coefficient "C" from Table 5.2. The coefficient chosen should represent the maximum runoff conditions during site construction — not necessarily the pre- or post-construction conditions. For drainage areas with mixed land uses, compute the weighted runoff coefficient ( $C_w$ ) using the following equation:

$$C_w = \frac{(C_1 \times A_1) + (C_2 \times A_2) + \dots (C_n \times A_n)}{A \text{ (total)}}$$

Where:  $C_w$  = weighted runoff coefficient  
 $C_n$  = runoff coefficient for the  $n^{\text{th}}$  subarea  
 $A_n$  = area (acres) of the  $n^{\text{th}}$  subarea

**TABLE 5.2**  
**Runoff Coefficients for the Rational Equation\***

LAND USE	A Soils <sup>1</sup>			B Soils <sup>1</sup>			C Soils <sup>1</sup>			D Soils <sup>1</sup>		
	< 2%	2 - 6%	>6%	< 2%	2 - 6%	>6%	< 2%	2 - 6%	>6%	< 2%	2 - 6%	>6%
Cultivated land	0.08	0.13	0.16	0.11	0.15	0.21	0.14	0.19	0.26	0.18	0.23	0.31
Pasture	0.12	0.20	0.30	0.18	0.28	0.37	0.24	0.34	0.44	0.30	0.40	0.50
Meadow	0.10	0.16	0.25	0.14	0.22	0.30	0.20	0.28	0.36	0.24	0.30	0.40
Forest	0.05	0.08	0.11	0.08	0.11	0.14	0.10	0.13	0.16	0.12	0.16	0.20
Residential lot size 1/8 acre	0.25	0.28	0.31	0.27	0.30	0.35	0.30	0.33	0.38	0.33	0.36	0.42
Residential lot size 1/4 acre	0.22	0.26	0.29	0.24	0.29	0.33	0.27	0.31	0.36	0.30	0.34	0.40
Residential lot size 1/3 acre	0.19	0.23	0.26	0.22	0.26	0.30	0.25	0.29	0.34	0.28	0.32	0.39
Residential lot size 1/2 acre	0.16	0.20	0.24	0.19	0.23	0.28	0.22	0.27	0.32	0.26	0.30	0.37
Residential lot size 1 acre	0.14	0.19	0.22	0.17	0.21	0.26	0.20	0.25	0.31	0.24	0.29	0.35
Industrial	0.67	0.68	0.68	0.68	0.68	0.69	0.68	0.68	0.69	0.69	0.69	0.70
Commercial	0.71	0.71	0.72	0.71	0.72	0.72	0.72	0.72	0.72	0.72	0.72	0.72
Streets	0.70	0.71	0.72	0.71	0.72	0.74	0.72	0.73	0.76	0.73	0.75	0.78
Open Space	0.05	0.10	0.14	0.08	0.13	0.19	0.12	0.17	0.24	0.15	0.21	0.28
Parking	0.85	0.86	0.87	0.85	0.86	0.87	0.85	0.86	0.87	0.85	0.86	0.87
Construction Sites - Bare packed soil, smooth	0.30	0.35	0.40	0.35	0.40	0.45	0.40	0.45	0.50	0.50	0.55	0.60
Construction Sites - Bare packed soil, rough	.020	0.25	0.30	0.25	0.30	0.35	0.30	0.35	0.40	0.40	0.45	0.50

\* Runoff Coefficients for storm recurrence intervals less than 25 years

Adapted from McCuen, R.H., Hydrologic Analysis and Design (2004)

1. According to the USDA NRCS Hydrologic Soils Classification System

Rainfall Intensity (I):

Step 1: Calculate Time of Concentration — travel time for the hydraulically longest watershed flow path.

**Sheet Flow (Overland Flow)**

Travel time for sheet flow, up to a maximum of 150 feet, may be estimated by the use of the formula:

$$T_{c(\text{sheet flow})} = \left[ \frac{2(L)(n)}{3(S)^{0.5}} \right]^{0.4673}$$

- Where:
- T<sub>c</sub> = Time of concentration (minutes)
  - L = Length of flow path (ft)
  - S = Surface slope (ft/ft)
  - n = Roughness coefficient (See Table 5.3)

**NOTE:** The maximum flow path length (L) for any disturbed area is 50 feet. Do not use the sheet flow equation for newly graded fills or cut slopes. Runoff from these areas should be considered shallow concentrated flow.

**TABLE 5.3**  
**Roughness Coefficient for Sheet Flow T<sub>c</sub> Computations**

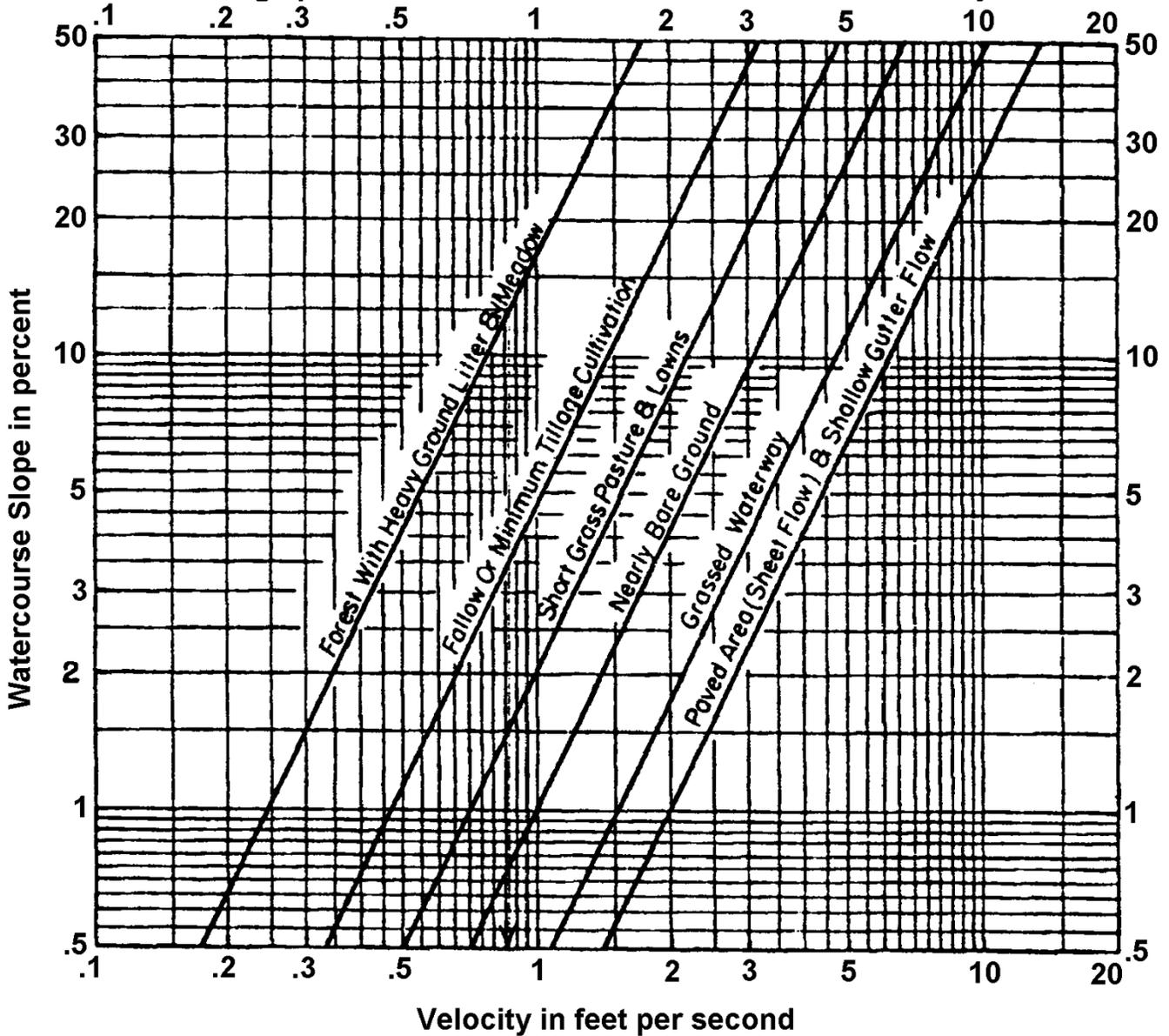
n	Type of Cover
0.02	Smooth pavement
0.1	Bare parched soil
0.3	Poor grass cover
0.4	Average grass cover
0.8	Dense grass cover

## Shallow Concentrated Flow

That portion of the flow path which is not channelized and cannot be considered sheet flow is considered shallow concentrated flow. The average velocity for shallow concentrated flow may be determined from Figure 5.1, in which average velocity is a function of slope and type of watercourse. **Note:** There is no maximum length for shallow concentrated flow in Pennsylvania.

FIGURE 5.1

Nomograph to Determine Shallow Concentrated Flow Velocity



TR-55

## Channel Flow

For open channels, calculate flow velocities by use of Manning's equation. Assume full bank flow conditions.

## Time of Concentration

Add all flow times (sheet, shallow concentrated, and channel flows) to determine time of concentration ( $T_c$ ) in minutes.

Step 2. Once the time of concentration has been calculated, the rainfall intensity for a 2-year frequency storm can be determined from the following equation<sup>1</sup>:

$$I = \frac{106}{T_c + 17}$$

For a 5- year storm the equation is: 
$$I = \frac{135}{T_c + 19}$$

For a 10- year storm the equation is: 
$$I = \frac{170}{T_c + 23}$$

An acceptable alternative to the above equations is the use of Tables 5.4 through 5.9 with Figures 5.2 through 5.12. For this method, determine the appropriate rainfall region map from Table 5.4 using the calculated time of concentration and the design storm event. Locate the project site on the appropriate rainfall region map and identify the rainfall region. Using the rainfall intensity chart for that region and the time of concentration, obtain the rainfall intensity.

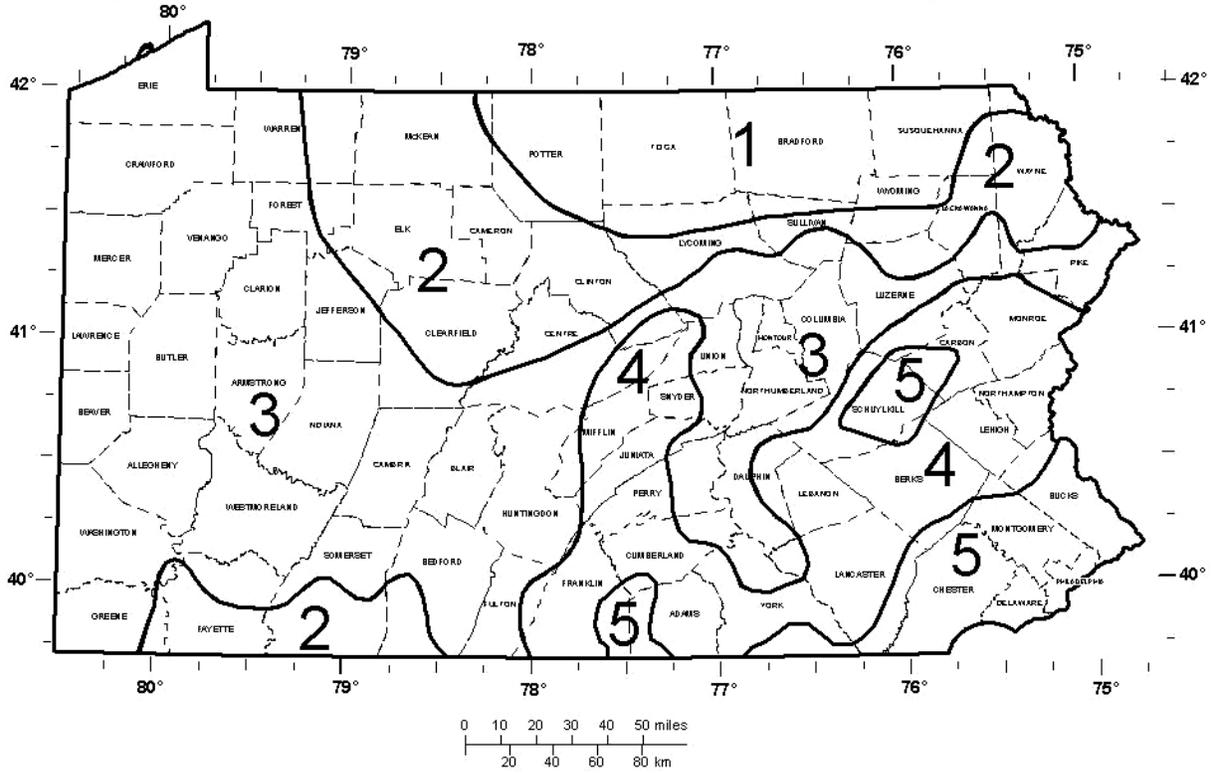
**TABLE 5.4**  
**Appropriate Rainfall Region Map for Various Times of Concentration and Frequencies**

Time of Concentration	Storm Return Frequency (ARI)							
	1 year	2 year	5 year	10 year	25 year	50 year	100 year	500 year
5 min	C	C	C	C	B	B	B	-
10 min	C	C	C	C	C	C	C	-
15 min	A	A	A	A	C	C	C	-
30 min	A	A	A	A	A	C	C	-
60 min	A	A	A	A	A	C	C	-
2 hr	E	E	E	E	E	E	E	-
3 hr	E	E	E	E	E	E	E	-
6 hr	D	D	D	D	D	D	D	-
12 hr	F	F	F	F	F	F	F	-
24 hr	F	F	F	F	F	F	F	F

Adapted from Appendix A of PennDOT Publication 584 (2008 Edition)

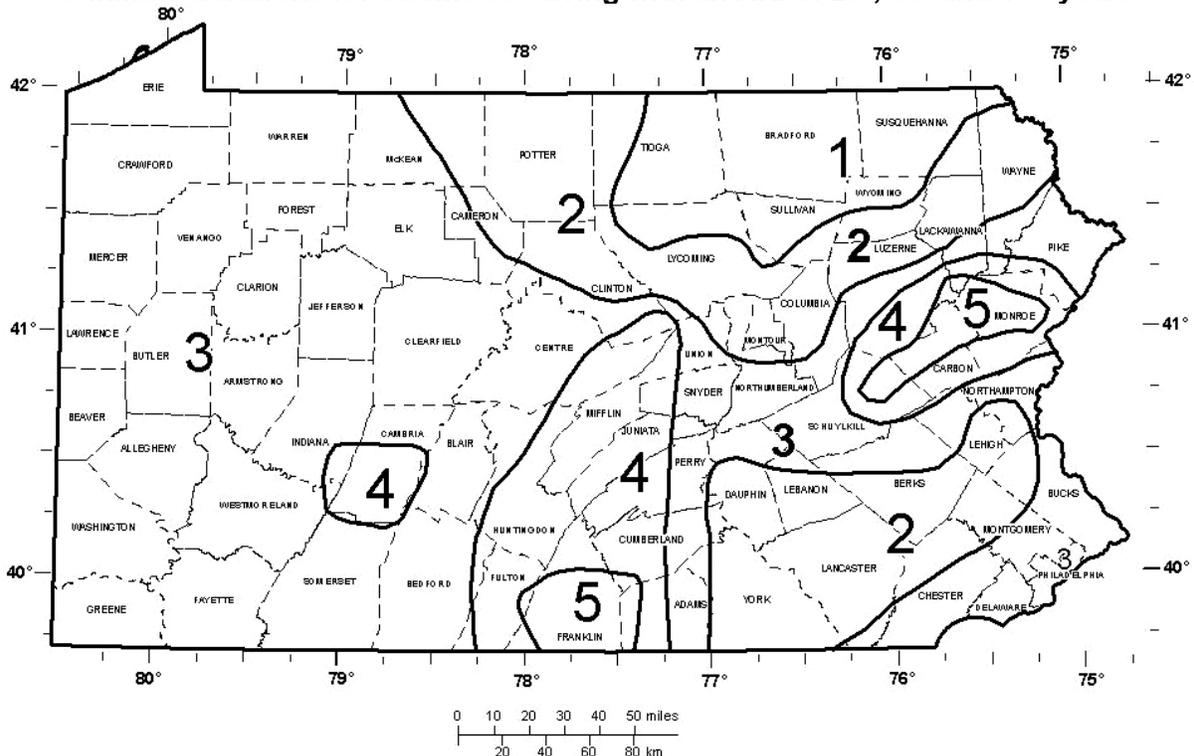
1. Adapted from Lindeberg (2001).

**Figure 5.2 - RAINFALL REGION MAP A**  
 15-, 30- and 60-minute durations for storms occurring with an ARI of 1-, 2-, 5-, 10-years and 30- and 60-minute durations for storms occurring with an ARI of 25-years



Adapted from Appendix A of PennDOT Publication 584 (2008 Edition)

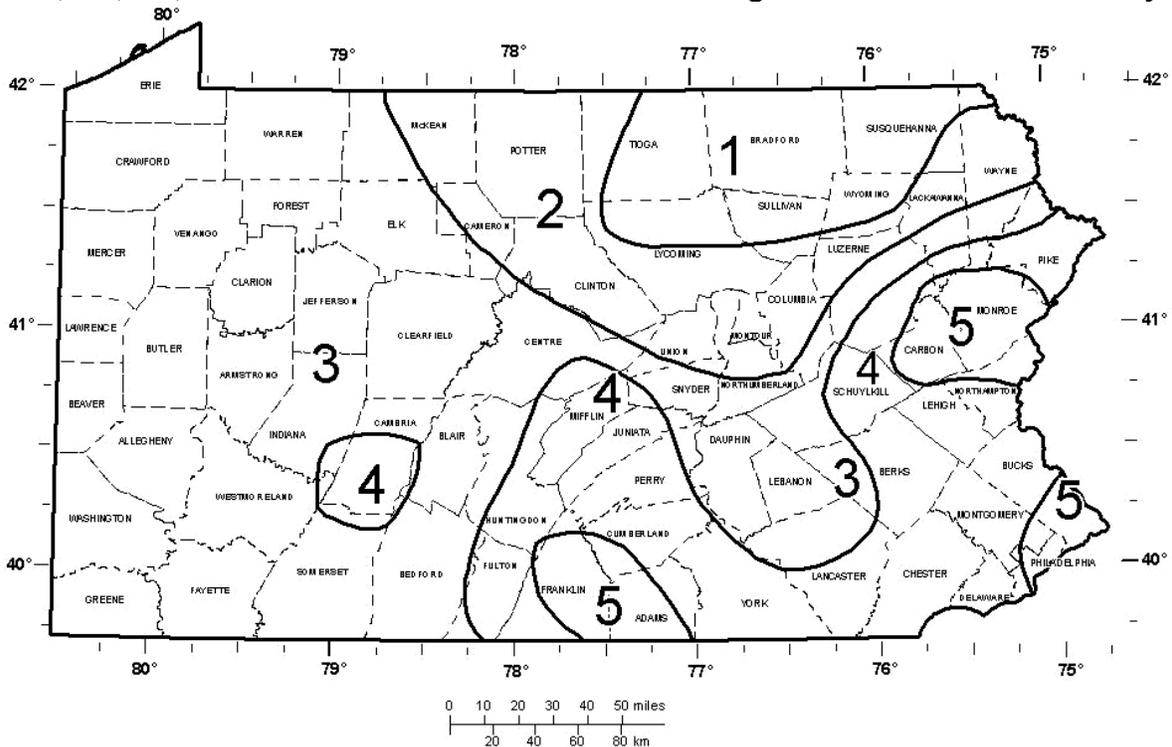
**Figure 5.3 - RAINFALL REGION MAP B**  
 5-minute durations for storms occurring with an ARI of 25-, 50- and 100-years



Adapted from Appendix A of PennDOT Publication 584 (2008 Edition)

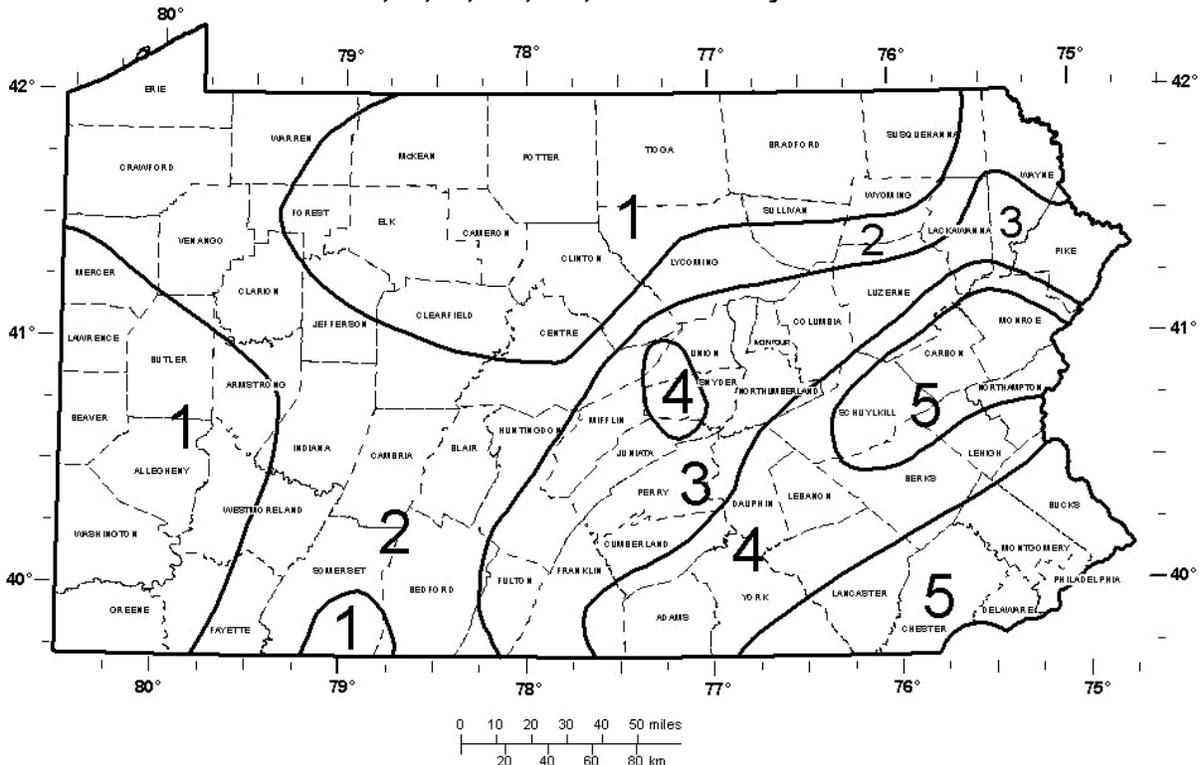
**Figure 5.4 - RAINFALL REGION MAP C**

5- and 10-minute durations for storms occurring with an ARI of 1-, 2-, 5-, and 10-years, 10- and 15-minute durations for storms occurring with an ARI of 25-years and 10-, 15-, 30-, 60-minute durations for storms occurring with an ARI of 50- and 100-years



Adapted from Appendix A of PennDOT Publication 584 (2008 Edition)

**Figure 5.5 - RAINFALL REGION MAP D**  
6-hour durations for storms occurring with an ARI of 1-, 2-, 5-, 10-, 25-, 50- and 100-years



Adapted from Appendix A of PennDOT Publication 584 (2008 Edition)



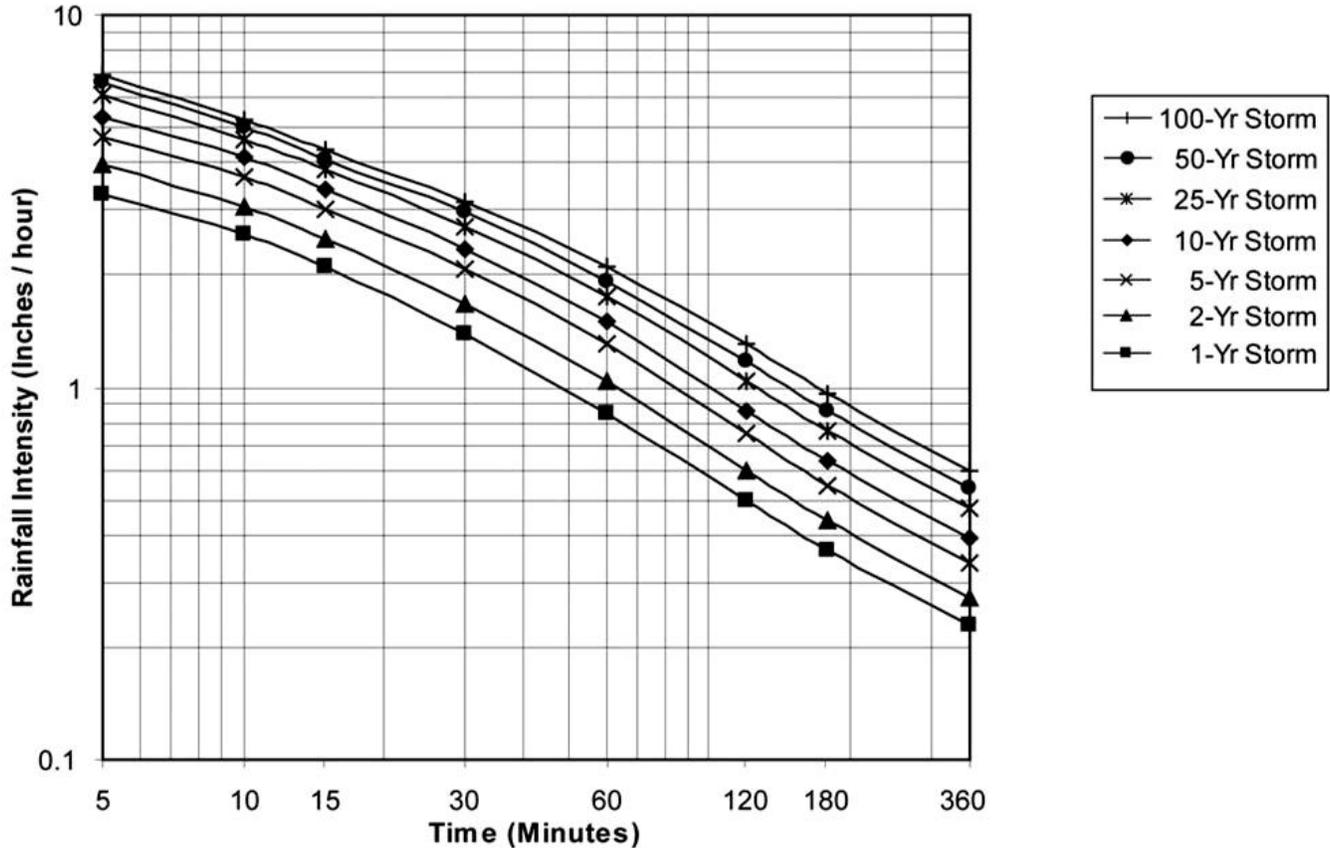


**TABLE 5.5**  
**5-Minute through 24-Hour Rainfall Depths for Region 1**

Time of Concentration	Rainfall Depth (in)							
	1 year	2 year	5 year	10 year	25 year	50 year	100 year	500 year
5 min	0.28	0.33	0.39	0.45	0.51	0.55	0.58	-
10 min	0.43	0.51	0.61	0.69	0.78	0.83	0.87	-
15 min	0.53	0.63	0.75	0.85	0.96	1.03	1.09	-
30 min	0.70	0.84	1.03	1.18	1.36	1.47	1.57	-
60 min	0.85	1.03	1.30	1.50	1.76	1.94	2.10	-
2 hr	0.99	1.19	1.49	1.74	20.8	2.35	2.62	-
3 hr	1.09	1.31	1.63	1.90	2.28	2.58	2.89	-
6 hr	1.37	1.64	2.04	2.37	2.84	3.19	3.56	-
12 hr	1.69	2.02	2.49	2.91	3.52	3.97	4.46	-
24 hr	2.04	2.44	2.99	3.44	4.09	4.65	5.24	6.74

Adapted from Appendix A of PennDOT Publication 584 (2008 Edition)

**Figure 5.8**  
**Rainfall Intensity for 1-year through 100-year Storms for Region 1**



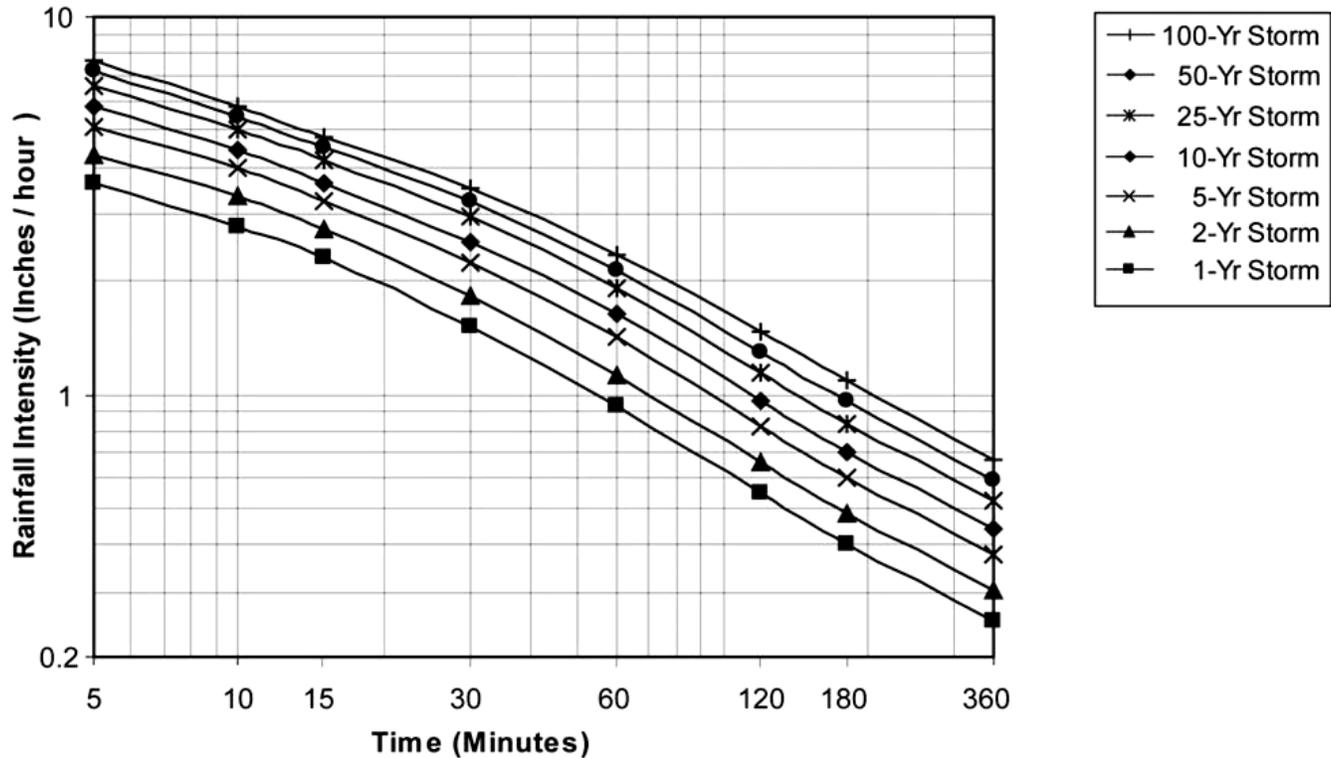
Adapted from Appendix A of PennDOT Publication 584 (2008 Edition)

**TABLE 5.6**  
**5-Minute through 24-Hour Rainfall Depths for Region 2**

Time of Concentration	Rainfall Depth (in)							
	1 year	2 year	5 year	10 year	25 year	50 year	100 year	500 year
5 min	0.30	0.36	0.43	0.48	0.55	0.60	0.64	-
10 min	0.47	0.56	0.66	0.74	0.84	0.91	0.97	-
15 min	0.57	0.68	0.81	0.91	1.04	1.13	1.20	-
30 min	0.76	0.92	1.12	1.27	1.47	1.61	1.74	-
60 min	0.93	1.13	1.42	1.63	1.92	2.13	2.33	-
2 hr	1.09	1.32	1.65	1.92	2.29	2.60	2.94	-
3 hr	1.20	1.45	1.81	2.10	2.52	2.87	3.25	-
6 hr	1.51	1.81	2.26	2.63	3.16	3.57	4.00	-
12 hr	1.86	2.23	2.76	3.23	3.92	4.47	5.06	-
24 hr	2.24	2.68	3.30	3.82	4.60	5.27	6.03	8.15

Adapted from Appendix A of PennDOT Publication 584 (2008 Edition)

**Figure 5.9**  
**Rainfall Intensity for 1-year through 100-year Storms for Region 2**



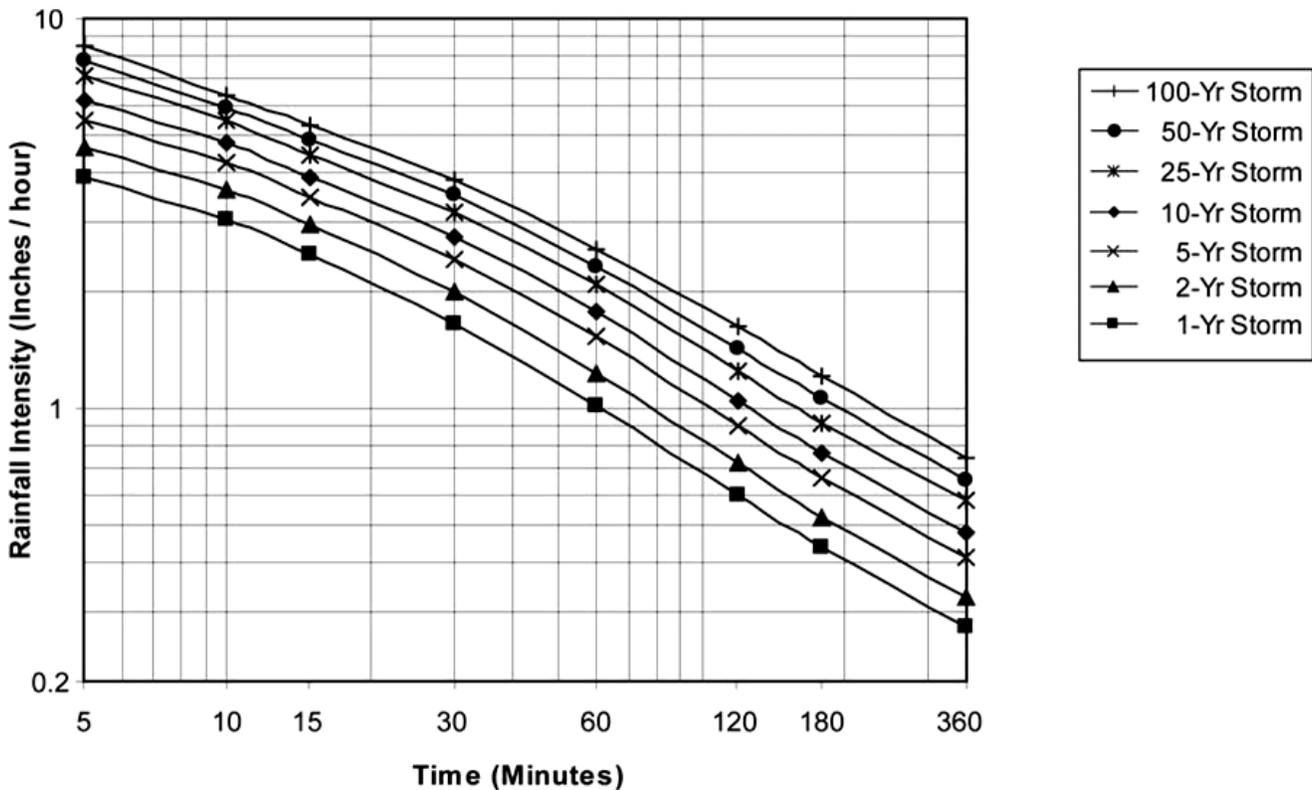
Adapted from Appendix A of PennDOT Publication 584 (2008 Edition)

**TABLE 5.7**  
**5-Minute through 24-Hour Rainfall Depths for Region 3**

Time of Concentration	Rainfall Depth (in)							
	1 year	2 year	5 year	10 year	25 year	50 year	100 year	500 year
5 min	0.32	0.39	0.46	0.51	0.59	0.65	0.71	-
10 min	0.50	0.60	0.71	0.80	0.91	0.99	1.06	-
15 min	0.62	0.74	0.88	0.98	1.12	1.22	1.32	-
30 min	0.82	0.99	1.20	1.37	1.59	1.75	1.92	-
60 min	1.01	1.23	1.53	1.77	2.08	2.32	2.57	-
2 hr	1.19	1.44	1.81	2.10	2.51	2.85	3.26	-
3 hr	1.31	1.58	1.98	2.30	2.77	3.16	3.62	-
6 hr	1.64	1.98	2.48	2.89	3.48	3.95	4.45	-
12 hr	2.03	2.44	3.03	3.55	4.33	4.97	5.66	-
24 hr	2.44	2.92	3.61	4.20	5.10	5.90	6.83	9.57

Adapted from Appendix A of PennDOT Publication 584 (2008 Edition)

**Figure 5.10**  
**Rainfall Intensity for 1-year through 100-year Storms for Region 3**



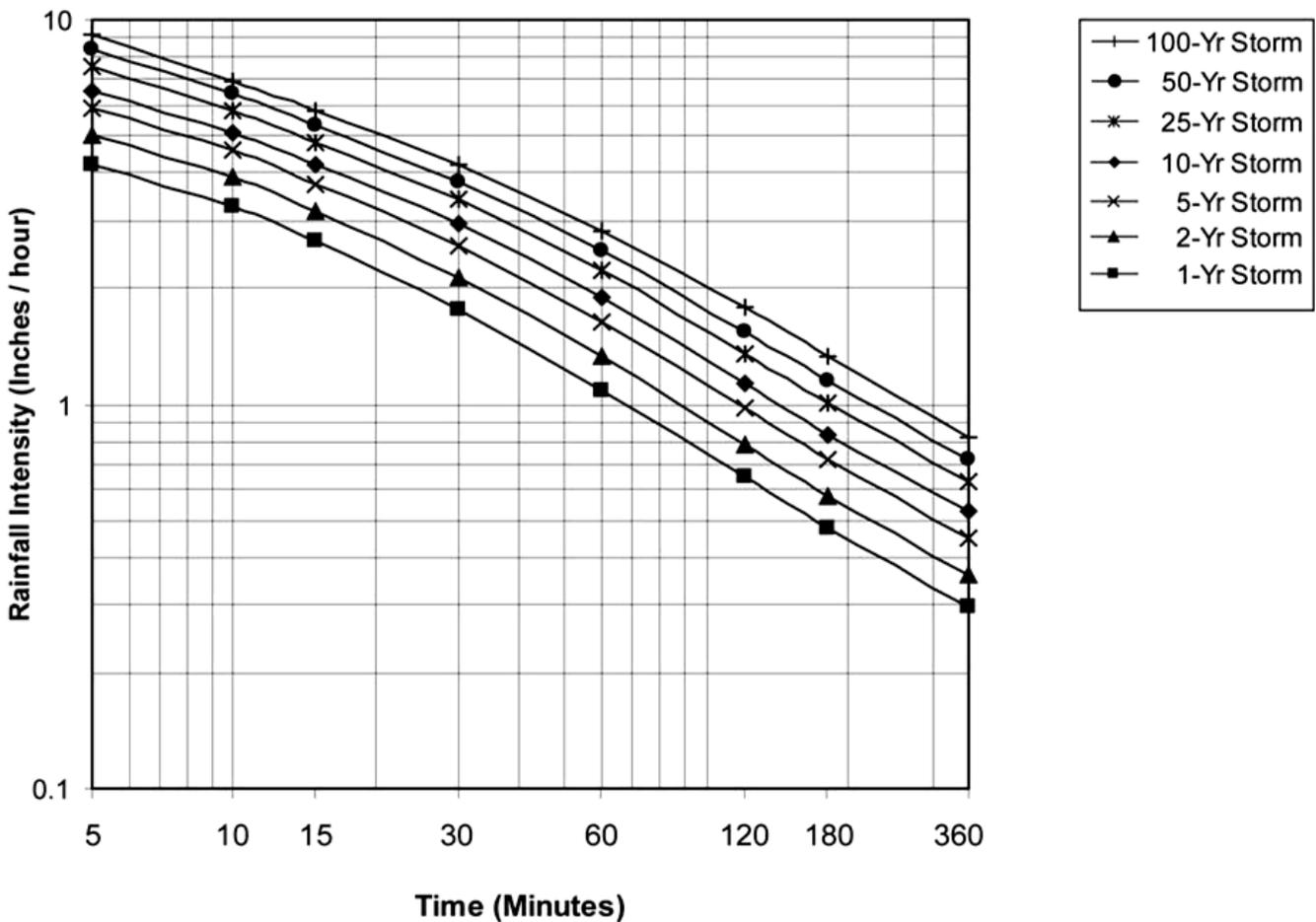
Adapted from Appendix A of PennDOT Publication 584 (2008 Edition)

**TABLE 5.8**  
**5-Minute through 24-Hour Rainfall Depths for Region 4**

Time of Concentration	Rainfall Depth (in)							
	1 year	2 year	5 year	10 year	25 year	50 year	100 year	500 year
5 min	0.35	0.42	0.49	0.55	0.63	0.70	0.77	-
10 min	0.54	0.65	0.76	0.85	0.97	1.07	1.16	-
15 min	0.67	0.79	0.94	1.05	1.21	1.32	1.44	-
30 min	0.88	1.07	1.29	1.47	1.71	1.90	2.09	-
60 min	1.09	1.32	1.65	1.90	2.23	2.51	2.80	-
2 hr	1.29	1.57	1.96	2.28	2.72	3.09	3.58	-
3 hr	1.42	1.72	2.16	2.51	3.01	3.45	3.98	-
6 hr	1.77	2.14	2.70	3.15	3.80	4.33	4.89	-
12 hr	2.20	2.65	3.29	3.87	4.74	5.46	6.26	-
24 hr	2.64	3.16	3.91	4.57	5.60	6.53	7.63	10.98

Adapted from Appendix A of PennDOT Publication 584 (2008 Edition)

**Figure 5.11**  
**Rainfall Intensity for 1-year through 100-year Storms for Region 4**



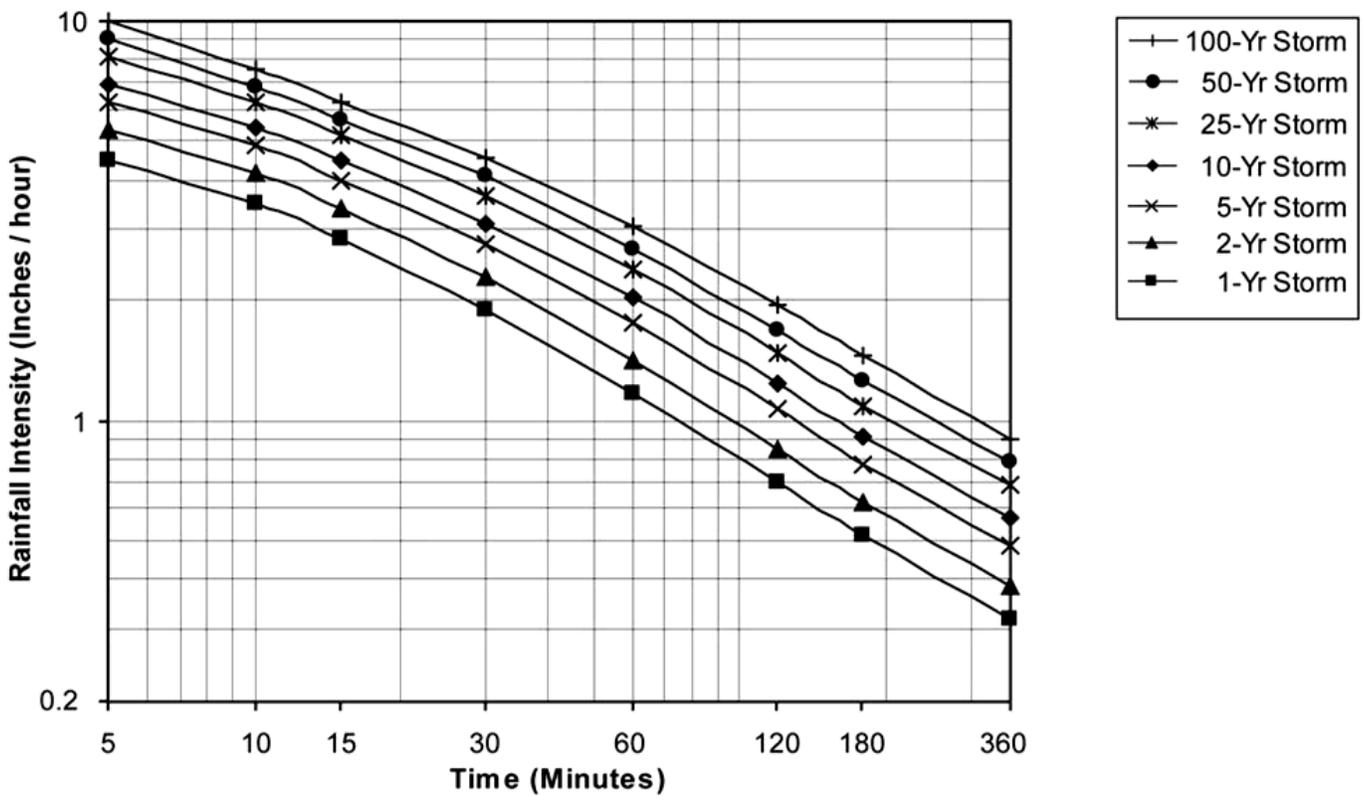
Adapted from Appendix A of PennDOT Publication 584 (2008 Edition)

**TABLE 5.9**  
**5-Minute through 24-Hour Rainfall Depths for Region 5**

Time of Concentration	Rainfall Depth (in)							
	1 year	2 year	5 year	10 year	25 year	50 year	100 year	500 year
5 min	0.37	0.45	0.52	0.58	0.68	0.75	0.83	-
10 min	0.58	0.69	0.81	0.90	1.04	1.15	1.26	-
15 min	0.71	0.85	1.00	1.11	1.29	1.42	1.56	-
30 min	0.94	1.14	1.37	1.56	1.82	2.04	2.27	-
60 min	1.17	1.42	1.76	2.03	2.39	2.69	3.04	-
2 hr	1.39	1.69	2.12	2.46	2.93	3.34	3.90	-
3 hr	1.53	1.86	2.33	2.71	3.25	3.75	4.34	-
6 hr	1.91	2.31	2.91	3.40	4.12	4.70	5.34	-
12 hr	2.37	2.86	3.56	4.20	5.15	5.96	6.86	-
24 hr	2.83	3.40	4.22	4.95	6.10	7.16	8.43	12.40

Adapted from Appendix A of PennDOT Publication 584 (2008 Edition)

**Figure 5.12**  
**Rainfall Intensity for 1-year through 100-year Storms for Region 5**



Adapted from Appendix A of PennDOT Publication 584 (2008 Edition)

Drainage Area (A) - Determine the drainage area in acres. Since drainage areas often change during grading operations, the area to be used is the maximum area tributary to the facility in question during construction. This will not necessarily be either the pre- or post-grading drainage areas.

Perform the calculations to determine the peak flow rate (cfs) for each desired frequency storm.

**SAMPLE COMPUTATION**

In this example, the peak runoff from a ten-acre watershed (3.5 acres wooded and 6.5 acres in meadow) above a proposed temporary diversion channel will be calculated for a site at State College, PA. From the NRCS soil map, it is determined that the site is located in soils belonging to the Opequon-Hagerstown complex (Hydrologic soil group C). The channel is 1,000 feet long, and the longest flow path above the channel is 435 feet (285 feet through meadow and 150 feet through woods). The slope immediately above the channel is 8% and wooded, while the meadow portion has a 3% slope. The proposed channel is trapezoidal, 2 feet deep and 2 feet wide at the bottom with 2H:1V side slopes. The channel has a uniform bed slope of 0.01 ft/ft; a grass lining with a temporary liner is provided. The 2-yr, 1-hour rainfall is 1.15 inches.

Determine the Weighted Runoff Coefficient ( $C_w$ ).

The forest is mature, so ground litter is light. Therefore, a value of 0.40 is chosen for the wooded area. The meadow is native grasses, so a value of 0.15 is chosen.

Using the equation for a weighted runoff coefficient:

$$C_w = \frac{(C_1 \times A_1) + (C_2 \times A_2)}{A \text{ (total)}} = \frac{(.40 \times 3.5) + (.15 \times 6.5)}{(3.5 + 6.5)} = \frac{1.4 + .98}{10} = .24$$

Calculate the Time of Concentration ( $T_c$ ).

Sheet Flow - The maximum sheet flow length is 150 feet. From the soils map, it is determined that a significant component of this soil type is poorly drained. Therefore, a flow length less than the maximum is appropriate; 100 feet is selected. A value of 0.8 is chosen for the “n” value of the meadow (Table 5.3). By plugging this figure into the Overland Flow equation, we can calculate a travel time of 14.55 minutes.

Shallow Concentrated Flow - Since only 100 feet of the 435’ flow path is sheet flow, the remainder (335’) is considered shallow concentrated. 185 feet of that is still in meadow, while 150 feet is through a wooded area. On Figure 5.1, the watercourse slope of 0.03 ft/ft (3%) is located along the left hand side. Following a horizontal line to the intersection with the “Fallow or Minimum Tillage Cultivation” line, the average velocity (0.8 fps) is read along the bottom. This is the average velocity of the runoff for the remainder of the meadow flow path. The travel time for shallow concentrated flow though meadow is  $(185/0.8) \div 60$  seconds per minute = 3.85 minutes. Similarly, the 150’ flow path through the woods (8% slope) has an average velocity of 0.70 ft/sec for a travel time of 3.57 minutes.

Channel Flow - In this portion of the calculation, the proposed channel dimensions are used to estimate the travel time within the temporary channel. Using Manning’s equation, the flow velocity within the channel is calculated to be 3.95 fps. By dividing the length of the channel (1,000 ft) by the average velocity, the travel time for this segment is determined to be 4.22 minutes  $(1,000/3.95 \div 60$  seconds per minute).

Total Time of Concentration ( $T_c$ ) is the sum of the sheet flow, shallow concentrated, and channel flow  $(14.55 + 3.85 + 3.57 + 4.22 = 26.19$  minutes).

Determine Rainfall Intensity (I)

$$I = \frac{106}{T_c + 17} = \frac{106}{26.19 + 17} = \frac{106}{45.19} = 2.45 \text{ in/hr}$$

Calculate the peak runoff rate for a 2-year frequency storm using the Rational Equation:

$$Q = C \times I \times A$$
$$Q = .24 \times 2.45 \times 10 = 5.9 \text{ cfs}$$

If this had been proposed as a permanent channel, the ten-year frequency rainfall depth would be required.

$$I = \frac{170}{T_c + 23} = \frac{170}{26.19 + 26} = \frac{170}{52.19} = 3.26 \text{ in/hr}$$

$$Q = .24 \times 3.26 \times 10 = 7.8 \text{ cfs}$$

If Tables 5.4 through 5.9 and Figures 5.2 through 5.12 are used, the appropriate rainfall region map would be Map A (Figure 5.2). State College is located in Region 3 on Map A. Therefore, using Figure 5.10, an intensity of 2.2 in/hr would be determined for the 2-year frequency storm, while the 10-year storm intensity would be 3.1 inches. Obviously these figures would result in peak runoffs slightly less than those calculated using the equations. However, the differences should not result in significant changes to any channels designed to convey those flows.



## Determination of Time of Concentration (T<sub>c</sub>) Using Standard E&S Worksheet # 9

NOTE: These tables are intentionally blank and should be filled in by the plan preparer.

### OVERLAND FLOW

PATH NUMBER	LENGTH L (ft)	"n" VALUE	AVERAGE SLOPE S (ft/ft)	TIME - T <sub>of</sub> (minutes)
DC-1	100	0.8	0.08	14.55

$$T_{c(\text{sheet flow})} = \frac{2(L)(n)^{0.4673}}{3(S)^{0.5}}$$

- 0.02 smooth pavement
- 0.1 bare parched soil
- 0.3 poor grass cover
- 0.4 average grass cover
- 0.8 dense grass cover
- (L = 150' maximum)

### SHALLOW CONCENTRATED FLOW:

PATH NUMBER	LENGTH (ft)	TYPE OF COVER	AVERAGE SLOPE (ft/ft)	V (ft/sec)	TIME - T <sub>sc</sub> (minutes)
DC-1	185	Meadow	0.03	0.80	3.85
	150	Woods	0.08	0.70	3.57

### CHANNEL FLOW:

PATH NUMBER	LENGTH (ft)	AREA (sq. ft.)	AVERAGE SLOPE (ft/ft)	WETTED PERIMETER (ft)	HYDRAULIC RADIUS (ft)	MANNING'S n	V (ft/sec)	CHANNEL TIME-T <sub>ch</sub> (minutes)	T <sub>c</sub> * (minutes)
DC-1	1,000	12	0.01	10.9	1.1	0.04	3.95	4.22	26.19

### CHANNEL DIMENSIONS:

PATH NUMBER	BOTTOM WIDTH (ft)	LEFT SIDE SLOPE (H:V)	RIGHT SIDE SLOPE (H:V)	TOTAL DEPTH (ft)	TOP WIDTH (ft)
DC-1	2.0	2:1	2:1	2.0	10.0

\* T<sub>c</sub> = Overland Flow Time + Shallow Concentrated Flow Time + Channel Flow Time

**Determination of Peak Runoff (Q) Using the Rational Formula  
and Standard Worksheet E&S # 10**

NOTE: These tables are intentionally blank and should be filled in by the plan preparer.

**DETERMINE WATERSHED "C" VALUES**

CHANNEL NUMBER	DRAINAGE AREA NUMBER	TYPE OF COVER	C VALUE	AREA (acres)	(C X A)	C <sub>w</sub>
DC-1	A	Woods	0.13	3.5	0.46	.28
	B	Meadow	0.36	6.5	2.34	
	Total			10.0	2.80	

**DETERMINE RAINFALL INTENSITY:**

CHANNEL NUMBER	T <sub>c</sub>	Rainfall Depth R <sub>2</sub>	R <sub>5</sub>	R <sub>10</sub>	Rainfall Intensity I <sub>2</sub>	I <sub>5</sub>	I <sub>10</sub>
DC-1	26.19	2.6			2.7		

**DETERMINE PEAK RUNOFF RATES (Q = C x I x A)**

CHANNEL NUMBER	C <sub>w</sub>	I (inches/hr)	A (acres)	Q <sub>2</sub> (cfs)	Q <sub>5</sub> (cfs)	Q <sub>10</sub> (cfs)
DC-1	0.28	2.7	10	7.6		

## CHAPTER 6 - RUNOFF CONVEYANCE BMPs

The purpose of this chapter is to provide plan preparers with methods and procedures, examples, work forms and references to other commonly applied methods for the design of channels, berms, slope pipes, and other structures used to convey runoff around a work area or to a sediment removal facility. Methods listed or referenced in this chapter are generally considered to be the most commonly used methods and procedures in the field of erosion and sediment control. However, the listed or referenced materials are not all inclusive and the Department will, on a case-by-case basis, accept other methods and procedures that are correctly selected and applied by persons qualified and/or licensed to perform such computations. The Department encourages the use of methods and procedures listed or referenced in this manual. Such use will facilitate review of E&S plans by the Department or a conservation district.

**In general, runoff conveyance BMPs have little, if any, potential for sediment removal and are not ABACT BMPs for special protection watersheds. However, they may be used to make other BMPs that are ABACT work more effectively.**

### CHANNELS

Channels are used for several purposes. Collector channels are used to collect runoff from disturbed areas and convey it to a sediment removal facility prior to discharge into receiving surface waters. Diversion channels are used to divert runoff from undisturbed upslope areas and convey it around areas of earth disturbance. Conveyance channels are used to convey discharges from sediment removal facilities or stormwater outfalls to receiving surface waters. (NOTE: Berms, whether used as diversions or collectors, should be designed and stabilized in the same manner as channels.) In steep slope situations (bed slope  $\geq 10\%$ ) consideration should be given to the use of slope pipes (Standard Construction Detail # 6-5).

Design temporary channels to convey the required capacity ( $Q_r$ ), which is either 1.6 cfs/acre or the calculated peak discharge from a 2-year/1-hour storm event. In special protection watersheds, design temporary channels to convey 2.25 cfs/acre or the peak discharge from a 5-year/1-hour storm. Design all permanent channels to convey either 2.75 cfs/acre or the calculated peak discharge from a 10-year/1-hour storm event. If the Rational Method is used, it is recommended that Standard E&S Worksheets # 9 and # 10 be used to determine the required capacity ( $Q_r$ ).

Designs for temporary and permanent channels should include calculations that clearly demonstrate that the channels have sufficient capacity to safely convey the design flows to the points of discharge and that the channel beds and side slopes will be stable. Standard E&S Worksheet # 11 should be used for this purpose.

Align all channels and berms so as to provide positive drainage throughout. Sharp turns, high angles of confluence, and very low gradients ( $< 1\%$  bed slope) should be avoided wherever possible. Channels typically require protective linings. The permissible velocity design method may be used for linings of channels with bed slopes less than 10%, while the allowable shear method is acceptable for all channel bed slopes. Use of rock check dams is not an acceptable alternative to a properly designed channel lining. Wherever it is necessary for construction vehicles to cross one of these channels, an adequately sized temporary crossing pipe with clean rock fill and clean rock approaches should be provided.

The permissible velocity or allowable shear stress used for lining design should be sustainable for a reasonable period of time (20 minutes minimum). Using a manufacturer's permissible velocity or allowable shear stress that is only sustainable for a short period of time can result in failure of the channel lining during design storm events; therefore the long-term values should be used for design purposes.

Channels requiring protective liners should be either trapezoidal or parabolic in cross-section. V-shaped channels are not recommended for channels having fabric or geotextile liners due to the tendency for gaps to be left under the lining at the bottom of the channel. Where it is necessary to construct V-shaped channels with fabric or geotextile liners, manufacturer's recommendations or PennDOT PUB 72 9RC-73M standards should be strictly followed.

**Manning's Equation** - Flow capacity and velocity in open channels are typically computed by use of Manning's equation. Use of this equation (including derivative forms) is recommended by the Department:

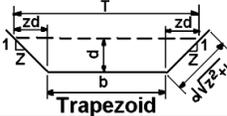
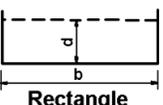
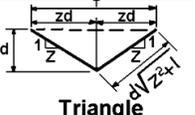
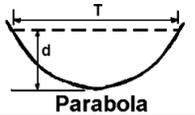
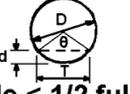
$$Q = \frac{1.486}{n} a r^{2/3} s^{1/2}$$

and

$$V = \frac{1.486}{n} r^{2/3} s^{1/2}$$

- Where: Q = Quantity of flow (cfs)  
 V = Velocity (fps)  
 n = Manning's coefficient of roughness  
 a = Cross-sectional area of channel (sq. ft)  
 P = Wetted perimeter of channel (ft)  
 r = Hydraulic radius of channel (ft) = a/P  
 s = Slope of channel bottom (ft/ft)

**TABLE 6.1  
 Geometric Elements of Channel Sections**

Section	Area a	Wetted Perimeter P	Hydraulic Radius r	Top Width T
 Trapezoid	$bd + zd^2$	$b + 2d\sqrt{z^2 + 1}$	$\frac{bd + zd^2}{b + 2d\sqrt{z^2 + 1}}$	$b + 2zd$
 Rectangle	$bd$	$b + 2d$	$\frac{bd}{b + 2d}$	$b$
 Triangle	$zd^2$	$2d\sqrt{z^2 + 1}$	$\frac{zd}{2\sqrt{z^2 + 1}}$	$2zd$
 Parabola	$\frac{2}{3} dT$	$T + \frac{8d^2}{3T}$ <sub>1</sub>	$\frac{2 dT^2}{3 T^2 + 8 d^2}$ <sub>1</sub>	$\frac{3 a}{2 d}$
 Circle < 1/2 full <sub>2</sub>	$\frac{D^2}{8} (\frac{\pi \theta}{180} - \sin \theta)$	$\frac{\pi D \theta}{360}$	$\frac{45D}{\pi \theta} (\frac{\pi \theta}{180} - \sin \theta)$	$\frac{D \sin \frac{\theta}{2}}{2}$ or $2\sqrt{d(D-d)}$
 Circle > 1/2 full <sub>3</sub>	$\frac{D^2}{8} (2\pi - \frac{\pi \theta}{180} + \sin \theta)$	$\frac{\pi D (360 - \theta)}{360}$	$\frac{45D}{\pi(360 - \theta)} (2\pi - \frac{\pi \theta}{180} + \sin \theta)$	$\frac{D \sin \frac{\theta}{2}}{2}$ or $2\sqrt{d(D-d)}$
<sub>1</sub> Satisfactory approximation for the interval $0 < d/T \leq 0.25$ When $d/T > 0.25$ , use $p = 1/2\sqrt{16d^2 + T^2} + \frac{T^2}{8d} \sin^{-1} \frac{4d}{T}$ <sub>2</sub> $\theta = 4 \sin^{-1} \sqrt{d/D}$ <sub>3</sub> $\theta = 4 \cos^{-1} \sqrt{d/D}$ } Insert $\theta$ in degrees in above equations				

## **DESIGN PROCEDURE**

1. Calculate the required capacity ( $Q_r$ ) for the channel or channel segment.
2. Determine whether the soil(s) in which the channel will be constructed have any limitations that will affect the stability of the channel or its protective lining. This can be determined by locating the proposed channel on the appropriate soils map on the NRCS website. Once the soil type has been identified, its susceptibility to erosion should be determined from the tables on the website. Soils having K factors less than or equal to 0.37 may be considered “*erosion resistant*,” all others should be considered “*easily eroded*.”
3. Select a channel shape and initial dimensions. Calculate the anticipated velocity ( $V_d$ ), using Manning’s equation, and the design shear stress ( $\tau_d$ ), using the equation:

$$\tau_d = 62.4 d \times s.$$

Where: d = Anticipated flow depth (ft)  
s = Channel Bed Slope (ft/ft)

**SLOPES MAY NOT BE AVERAGED.** If a proposed channel will intercept significant changes in slope — such as would require a larger channel size or different protective liner:

- 1.) Design each segment of the channel separately, or
- 2.) Design the entire channel with sufficient capacity for the gentlest slope and a protective liner suitable for the steepest slope.

The maximum bottom width to flow depth ratio for a trapezoidal channel is 12w:1d. Experience has shown that in channels with ratios exceeding 12w:1d, the flow tends to concentrate within the channel resulting in erosion of the channel bottom.

4. Determine whether a protective lining is needed (See Table 6.2) for channels discharging to sediment traps or basins. If the anticipated shear stress exceeds the maximum permissible for the type of soil present, a protective lining is needed. Geotextiles designed for this purpose may be used as temporary linings for some collector channels. A protective liner is required for all channels not discharging to a basin or trap as well as all channels located in special protection watersheds.

Determine whether the permissible velocity design method — for channels with bed slopes less than 10% — or the shear stress lining design method will be used. If the permissible velocity method is used, make sure that the design velocity does not exceed the permissible velocity listed in Table 6.4 (with attached notes), Table 6.6, or Table 6.10 as applicable. If the shear stress method is used, make sure the anticipated shear stress does not exceed that shown in Table 6.2 or manufacturer’s recommendations, based upon independent testing for at least 20 minutes.

**THE VALUE OF MANNING’S “n” SHOULD BE ADJUSTED ACCORDING TO TYPE OF CHANNEL LINING AND FLOW DEPTH.** Wherever vegetative stabilization is proposed, the “n” value may be calculated using the following equation (for Retardance C channels only):

$$n = 0.047\tau_o^{-0.4}$$

Where n = Manning’s roughness coefficient

$\tau_o$  = Mean Boundary Shear (lb/ft<sup>2</sup>) = 62.4RS  
R = Hydraulic Radius  
S = Bed Slope

For trapezoidal channels with up to 10' bottom width, Table 6.3 may be used to determine the “n” value. When rock riprap is proposed, use Figure 6.2 to determine the "n" value.

The seed mixture used in vegetative channels should be suitable for the anticipated flow conditions based on the channel location and type of soil(s) encountered. The Department recommends the use of Tables 11.3, 11.4, and 11.5 taken from the Penn State Publication, *Erosion Control and Conservation Plantings on Noncropland*, for selection of species to be used.

**TABLE 6.2**  
**Maximum Permissible Shear Stresses for Various Channel Liners**

Lining Category	Lining Type	lb/ft <sup>2</sup>
Unlined <sup>1</sup> - Easily Eroded Soils <sup>2</sup>	Silts, Fine -Medium Sands	0.03
	Coarse Sands	0.04
	Very Coarse Sands	0.05
	Fine Gravel	0.10
Unlined <sup>1</sup> - Erosion Resistant Soils <sup>3</sup>	Clay Loam	0.25
	Silty Clay Loam	0.18
	Sandy Clay Loam	0.10
	Loam	0.07
	Silt Loam	0.12
	Sandy Loam	0.02
	Gravelly, Stony, Channery Loam	0.05
	Stony or Channery Silt Loam	0.07
Manufactured Liners <sup>4</sup>	Jute	0.45
	Straw with Net	1.45
	Coir - Double Net	2.25
	Coconut Fiber -Double Net	2.25
	Curled Wood Mat	1.55
	Curled Wood-Double Net	1.75
	Curled Wood - Hi Velocity	2.00
	Synthetic Mat	2.00
Non Reinforced Vegetation	Retardance C assumed <sup>5</sup>	1.00
Riprap <sup>6</sup>	R-3	1.00
	R-4	2.00
	R-5	3.00
	R-6	4.00
	R-7	5.00
	R-8	8.00

1. Not permitted in HQ or EV watersheds
2. Soils having an erodibility “K” factor greater than 0.37.
3. Soils having an erodibility “K” factor less than or equal to 0.37
4. Manufacturer’s recommended maximum shear stresses may be used if supporting documentation is provided showing the higher shear stresses are justified by independent testing results over a time period of at least 20 minutes.
5. For description of Vegetative Retardance C, see USDOT, Federal Highway Administration Publication HEC15.
6. Permissible shear stresses based on rock at 165 lb/cu. ft. Adjust shear stresses for other rock weights used. See Table 6.8.

Adapted from USDOT, FHA HEC-15, 1988

**TABLE 6.3**

**Manning's "n" for Trapezoidal Channels with Vegetative Stabilization (Retardance C)**

Flow Depth (FT)	Channel Bed Slope (FT/FT)									
	0.01	0.02	0.03	0.04	0.05	0.06	0.07	0.08	0.09	0.10
0.1	0.15	0.11	0.10	0.09	0.08	0.07	0.07	0.07	0.06	0.06
0.2	0.12	0.09	0.08	0.07	0.06	0.06	0.05	0.05	0.05	0.05
0.3	0.10	0.08	0.07	0.06	0.05	0.05	0.05	0.04	0.04	0.04
0.4	0.09	0.07	0.06	0.05	0.05	0.05	0.04	0.04	0.04	0.04
0.5	0.08	0.07	0.06	0.05	0.05	0.04	0.04	0.04	0.04	0.03
0.6	0.08	0.06	0.05	0.05	0.04	0.04	0.04	0.04	0.03	0.03
0.7	0.08	0.06	0.05	0.04	0.04	0.04	0.04	0.03	0.03	0.03
0.8	0.07	0.06	0.05	0.04	0.04	0.04	0.03	0.03	0.03	0.03
0.9	0.07	0.05	0.05	0.04	0.04	0.04	0.03	0.03	0.03	0.03
1.0	0.07	0.05	0.04	0.04	0.04	0.03	0.03	0.03	0.03	0.03
2.0	0.06	0.04	0.04	0.03	0.03	0.03	0.03	0.02	0.02	0.02
3.0	0.05	0.04	0.03	0.03	0.03	0.02	0.02	0.02	0.02	0.02
4.0	0.04	0.03	0.03	0.03	0.02	0.02	0.02	0.02	0.02	0.02
5.0	0.04	0.03	0.03	0.02	0.02	0.02	0.02	0.02	0.02	0.02
6.0	0.04	0.03	0.02	0.02	0.02	0.02	0.02	0.02	0.02	0.02
7.0	0.04	0.03	0.02	0.02	0.02	0.02	0.02	0.02	0.01	0.01
8.0	0.03	0.02	0.02	0.02	0.02	0.02	0.02	0.01	0.01	0.01
9.0	0.03	0.02	0.02	0.02	0.02	0.02	0.02	0.01	0.01	0.01
10.0	0.03	0.02	0.02	0.02	0.02	0.02	0.01	0.01	0.01	0.01

PA DEP

NOTE: For vegetated channels that are not anticipated to have a retardance C value (e.g. frequently mowed channels), the equation on page 134 and Table 6.3 should not be used. The designer is referred to NRCS publications for guidance on designing vegetative channels with Retardances other than C.



Westmoreland Conservation District

**TABLE 6.4**  
**Maximum Permissible Velocities (ft/sec) for Channels Lined with Vegetation**

<b>Cover</b>	<b>Slope Range Percent</b>	<b>Erosion Resistant Soil<sup>1</sup></b>	<b>Easily Eroded Soil <sup>2</sup></b>
Bermuda Grass	0 - 5%	6.0 <sup>3</sup>	5.0
Kentucky Bluegrass		5.5 <sup>3</sup>	4.5
Tall Fescue (endophyte-free)		5.5 <sup>3</sup>	4.5
Grass Legume Mixture		4.5	3.5
Bermuda Grass	5-10 %	5.5 <sup>3</sup>	4.5
Kentucky Bluegrass		5.0	4.0
Tall Fescue (endophyte-free)		5.0	4.0
Grass Legume Mixture		3.5	3.0

Modified from USDA-NRCS

<sup>1</sup>Cohesive (clayey) fine grain soils and coarse grain soils with a plasticity index OF 10 TO 40 (CL, CH, SC and GC). **SOILS WITH K VALUES EQUAL TO OR LESS THAN 0.37.**

<sup>2</sup>**SOILS WITH K VALUES GREATER THAN 0.37.**

<sup>3</sup>Use velocities exceeding 5 ft/sec only where good cover and proper maintenance can be obtained.

**NOTE: These values subject to the 7 limitations below**

**ADDITIONAL NOTES REGARDING THE USE OF TABLE 6.4**

1. A velocity of 3.0 ft/sec should be the maximum if because of shade, soils or climate, only a sparse cover can be established or maintained.
2. **A velocity of 3.0 to 4.0 ft/sec should be used under normal conditions if the vegetation is to be established by seeding.**
3. A velocity of 4.0 to 5.0 ft/sec should be used only in areas if a dense, vigorous sod is obtained quickly or if water can be diverted out of the waterway while vegetation is being established.
4. A velocity of 5.0 to 6.0 ft/sec may be used on well established, good quality sod. Special maintenance may be required.
5. A velocity of 6.0 to 7.0 ft/sec may be used only on established, excellent quality sod, and only under special circumstances in which flow cannot be handled at a lower velocity. Under these conditions, special maintenance and appurtenant structures will be required.
6. If stone centers, or other erosion resistant materials supplement the vegetative lining, the velocities in the above table may be increased by 2.0 ft/sec.
7. When base flow exists, a rock lined low flow channel should be designed and incorporated into the vegetative lined channel section.

**WHEREVER VEGETATIVE LININGS ARE PROPOSED, A SUITABLE TEMPORARY LINER SHOULD BE PROVIDED UNLESS THE CHANNEL IS SODDED.** Separate calculations should be provided showing sufficient capacity and adequate protection both before and after establishment of the vegetation. Maximum shear stress and roughness coefficients for the temporary liners should conform to Table 6.2 or the manufacturer's specifications. Wherever manufacturer's specifications are used, they should be documented in the narrative. Table 6.5 provides roughness coefficients for some commonly used temporary liners. Manufacturer's recommended "n" values may be used if sufficient documentation is provided. Additional information on the design and use of channel linings may be obtained from the Federal Highway Administration's Hydraulic Engineering Circular No. 15 (April 1988). Copies of this publication may be obtained by contacting:



Sodding is a means of rapidly achieving vegetative cover in a waterway. Care should be taken to adequately prepare the underlying soil prior to laying the sod. See Chapter 11 for soil preparation standards. The sod type should consist of plant materials able to withstand the design velocity and/or shear. **Note: This method should only be used where sufficient soil exists to support the continued growth of the vegetation as well as full embedment of the anchoring devices.**

Sod strips should be laid perpendicular to the direction of flow with the ends tightly butted together (see Standard Construction Detail # 6-2).

**TABLE 6.5**  
**Manning’s Roughness Coefficient (“n”) for Commonly Used Temporary Channel Linings**

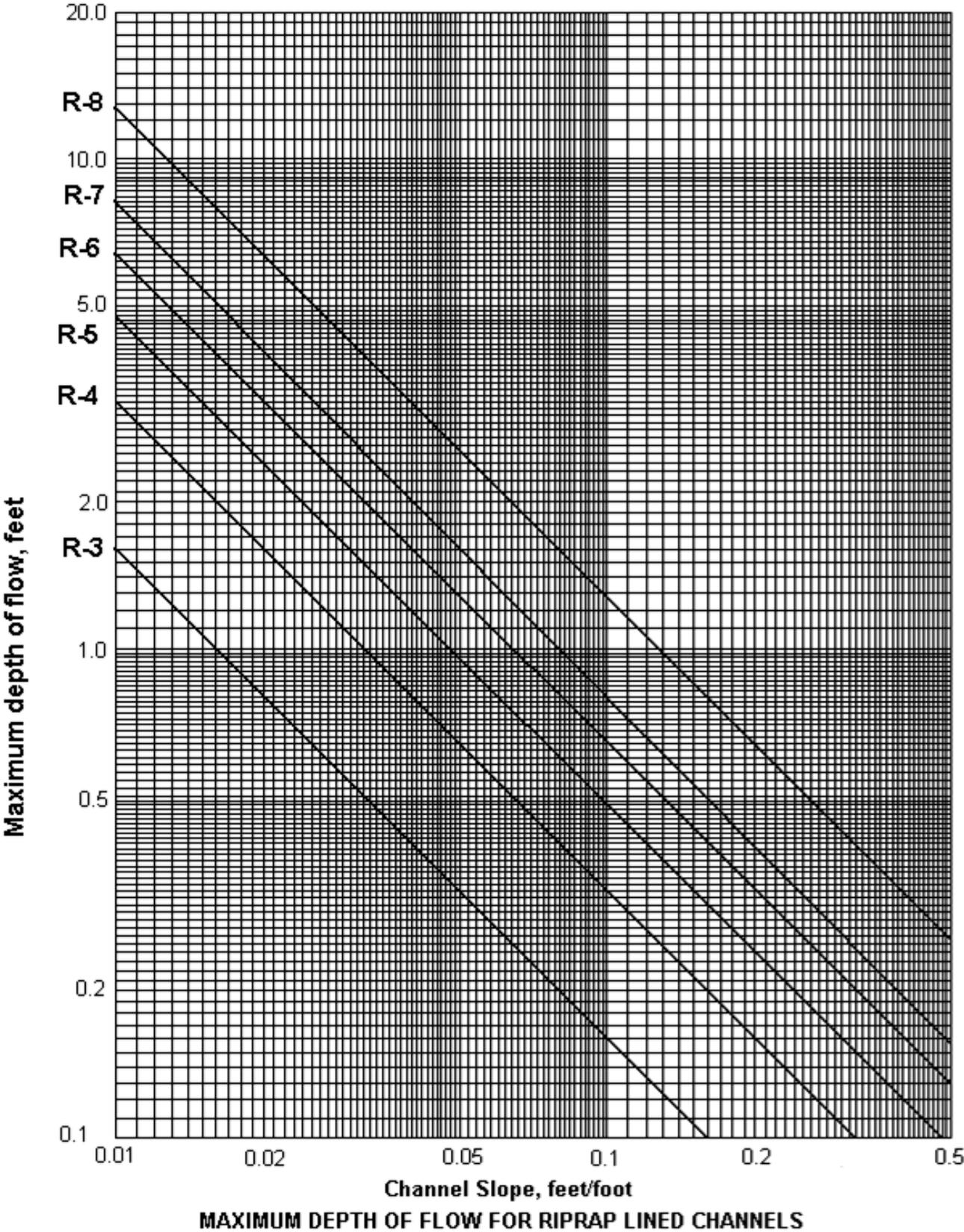
Lining Type	Manning’s “n” Flow Depth Ranges		
	0 - 0.5 ft. (0 - 0.15 m)	0.5 - 2.0 ft. (0.15 - 0.61 m)	>2.0 ft (>0.61 m)
Jute Net	0.028	0.022	0.019
Curled Wood Mat	0.066	0.035	0.028
Straw with Net	0.065	0.033	0.025
Synthetic Mat	0.036	0.025	0.021
Woven Paper Net	0.016	0.015	0.015

Adapted from FHWA HEC-15

The maximum permissible shear stresses for riprap channel linings are given in Table 6.2. An acceptable alternative to calculating shear stress for riprap channels is the use of Figure 6.1 to determine the maximum flow depth on top of the stone. For this method, a line is drawn vertically from the value at the bottom of the nomograph corresponding to the channel slope (ft/ft) to the horizontal line from the left side of the nomograph corresponding to the design maximum flow depth in the channel. If the intersection of those two lines falls at or below the slanted line representing the proposed riprap R-size, the maximum shear stress requirement for that channel is met.

The value of Manning’s “n” used should be taken from Figure 6.2. Since the roughness coefficient varies significantly with the size of the rock and the depth of flow, use of standard “n” values may result in undersizing of the channel or of the riprap protection. **NOTE: Due to the rapid increase in shear stress with the increasing bed slope, a 40% void space may be assumed in the riprap on channel bottoms (not side slopes) for gradients  $\geq 10\%$  (0.10 ft/ft).** Since this void space is filled before flow occurs on top of the riprap liner, the cross-sectional area of that void space may be subtracted from that of the in-channel flow prior to determining the anticipated flow depth to be used in the shear stress computation. If this results in a flow depth less than 0, use maximum velocity to size the riprap. If the resulting shear stress is still greater than the maximum permissible or if the flow depth exceeds the maximum shown on Figure 6.1, and the 12:1 flow width to depth ratio is reached, Reno mattresses, gabions, cable tied concrete, interlocking concrete blocks or other such lining should be considered.

**FIGURE 6.1**  
**Maximum Permissible Flow Depth for Riprap Channels**



Adapted from VDH&T Drainage Manual

**TABLE 6.6**  
**Riprap Gradation, Filter Blanket Requirements, Maximum Velocities**

Percent Passing (Square Openings)						
Class, Size NO.	R-8	R-7	R-6	R-5	R-4	R-3
Rock Size (Inches)						
42	100					
30		100				
24	15-50		100			
18		15-50		100		
15	0-15					
12		0-15	15-50		100	
9				15-50		
6			0-15		15-50	100
4				0-15		
3					0-15	15-50
2						0-15
<b>Nominal Placement Thickness (inches)</b>	63	45	36	27	18	9
<b>Filter Stone<sup>1</sup></b>	AASHTO #1	AASHTO #1	AASHTO #1	AASHTO #3	AASHTO #3	AASHTO #57
<b>V<sub>max</sub> (ft/sec)</b>	17.0	14.5	13.0	11.5	9.0	6.5

Adapted from PennDOT Pub. 408, Section 850.2(a)2

- 1 This is a general standard. Soil conditions at each site should be analyzed to determine actual filter size. A suitable woven or non-woven geotextile underlayment, used according to the manufacturer's recommendations, may be substituted for the filter stone for gradients < 10%.

**TABLE 6.7**  
**Comparison of Various Gradations of Coarse Aggregates**

Total Percent Passing															
AASHTO NUMBER	6 ½"	4"	3 ½"	2 ½"	2"	1 ½"	1"	¾"	½"	⅜"	#4	#8	#16	#30	#100
1		100	90-100	25-60		0-15		0-5							
3				100	90-100	35-70	0-15		0-5						
5						100	90-100	20-55	0-10	0-5					
57						100	90-100		25-60		0-10	0-5			
67							100	90-100		20-55	0-10	0-5			
7								100	90-100	40-70	0-15	0-5			
8									100	85-100	10-30	0-10	0-5		
10										100	75-100				10-30

PennDOT Publication 408, Section 703.2(c), Table C

Tables 6.6 and 6.7 should be placed on the plan drawings of all sites where riprap channel linings are proposed.

Riprap Specifications - Rock utilized for riprap should consist of sound, durable rock, insoluble in water. **Note: This does not exclude limestone** since the rate of dissolving for limestone is very low for non-acidic waters. Riprap should be free of structural defects, shale seams, and foreign materials such as quarry dust, soil, shale, and organic matter. Individual pieces should be sharply angular, whenever possible, block-shaped and have a minimum specific gravity of 2.5. Where rock is used having average unit weights that vary significantly from 165 lb/ft<sup>3</sup>, the size of the individual pieces should be adjusted according to Table 6.8. No piece should have a length exceeding three (3) times its width or depth. Each load should be well-graded from the smallest to the largest stone size. Pieces smaller than the minimum size may not exceed 15% of the tonnage shipped. Minimum placement thickness should be equal to 1.5 times the maximum stone size ( $d_{max}$ ).

**TABLE 6.8  
Riprap Size Adjustment Factor for Various Rock Types**

Rock Type	Average Unit Weight (lb/ft <sup>3</sup> )	Adjustment Factor
Diabase	184	0.5
Granite	167	1.0
Limestone	165	1.0
Sandstone	151	1.5

PA DEP

Example: To use riprap composed of sandstone, multiply the maximum, minimum and  $d_{50}$  stone sizes from Table 6.6 by 1.5. Thus, for an R-5 sandstone riprap, the maximum stone size should be 27", the  $d_{50}$  stone size 13.5", and the minimum stone size 6". Since quarries generally grade rock riprap to the common "R" sizes, in this example the sandstone would need to be an R-6 gradation.



PA DEP

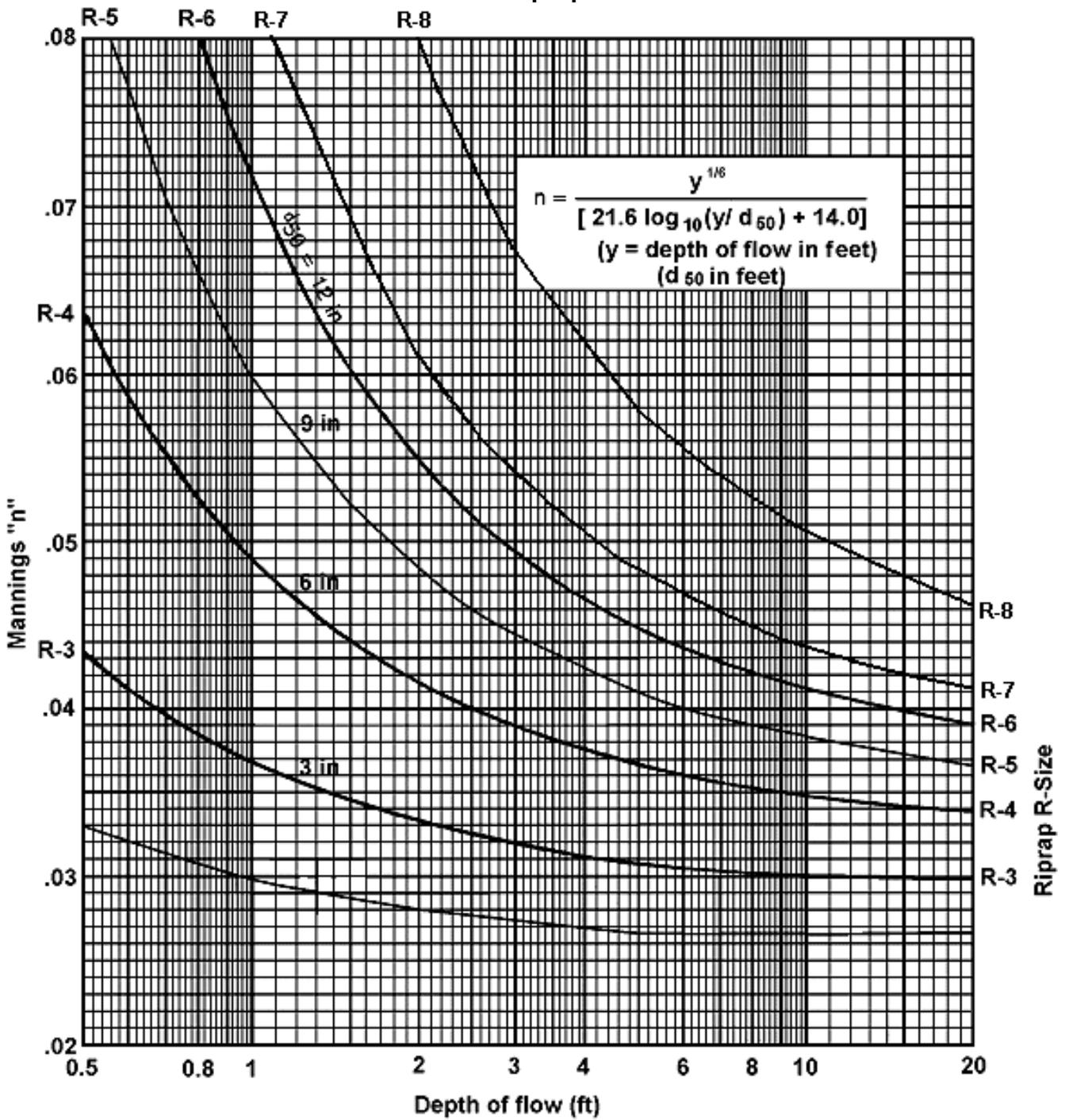
**TABLE 6.9**  
**Recommended n Values to be Used with Manning's Equation When Doing Stability**  
**Analyses of Receiving Streams**

**Design values should be utilized unless documentation is provided**  
**(narrative/calculations) to show that another value within the minimum and maximum**  
**range is appropriate.**

Surface	Min.	Design	Max.
Asphalt Lining		0.015	
Brick in cement mortar; brick sewers	0.012	0.015	0.017
Concrete-lined channel	0.012	0.015	0.018
Cement-rubble surface	0.017		0.030
Neat cement surfaces	0.010	0.012	0.013
Plastic-lined channel	0.012		0.014
Shotcrete	0.016		0.017
Asbestos Cement Pipe		0.009	
Concrete pipe	0.012	0.015	0.016
Vitrified Clay Pipe	0.010	0.013	0.017
Common-clay drainage tile	0.011	0.012	0.017
Semi-circular metal flumes, smooth	0.011		0.015
Corrugated	0.023	0.025	0.030
Channels and ditches			
Earth, straight and uniform	0.017	0.023	0.025
Rock cuts, smooth and uniform	0.025	0.030	0.035
jagged and irregular	0.035	0.040	
Dredged earth channels	0.025	0.028	0.033
Earth bottom, rubble sides	0.028	0.030	0.035
Natural Streams			
1. Clean, straight bank, full stage no rifts or deep pools	0.025		0.033
2. Same as 1, but some weeds and stones	0.030		0.040
3. Winding, some pools and shoals, clean	0.033		0.045
4. Same as 3, lower stages, more ineffective slope and sections	0.040		0.055
5. Same as 3, same weeds and stone	0.035		0.050
6. Same as 4, stony sections	0.045		0.060
7. Sluggish river reaches, rather weedy or with very deep pools	0.050		0.080
8. Very weedy reaches	0.075		0.150

Adapted from Table 3.1 in *Applied Hydrology and Sedimentology for Disturbed Areas*

Figure 6.2  
 "n" Values for Riprap Channels



Adapted from USDA-NRCS

**TABLE 6.10**  
**Maximum Permissible Velocities and Shear Stresses for Reno Mattress and Gabions**

Type	n	Thickness Inches	Rock Fill Gradation (in)	Permissible Velocity (fps)	Permissible Shear Stress (lb/ft <sup>2</sup> )
Reno Mattress	.026 - .030	6	3 - 6	6.0	4.27
	.026 - .030	9	3 - 6	12.0	4.58
Gabion	.026 - .030	12	3 - 6	15.0	4.73
	.028 - .030	18	4 - 6	18.0	5.20
	.029 - .032	36	5 - 9	22.0	8.35

Adapted from Maccaferri Gabions, Inc.

5. Calculate the Required Freeboard.

Determine whether stable or unstable flow conditions exist. Uniform flow at or near “critical depth” is unstable due to waves present at the water’s surface. Since the height of the waves may exceed the top of the channel, sufficient freeboard should be provided to prevent channel failure. The procedure for determining whether channel flow conditions are stable or unstable is as follows:

Compute the channel’s critical slope:

$$S_c = 14.56 n^2 D_m / R^{4/3}$$

- Where:  $S_c$  = critical slope (ft/ft)  
 $n$  = Manning’s “n”  
 $D_m$  = mean depth of flow =  $A/T$  (ft)  
 $A$  = cross-sectional area of the channel (sq. ft.)  
 $T$  = channel top width at the water surface (ft)  
 $R$  = hydraulic radius =  $A/P$  (ft)  
 $P$  = wetted perimeter (ft)

Unstable flow occurs when  $0.7S_c \leq S_o \leq 1.3S_c$

Where:  $S_o$  = channel bed slope.

Compute the minimum required freeboard.

If unstable flow conditions exist, compute the minimum required freeboard as follows:

$$F = (0.025 V) (3 D) = 0.075 VD$$

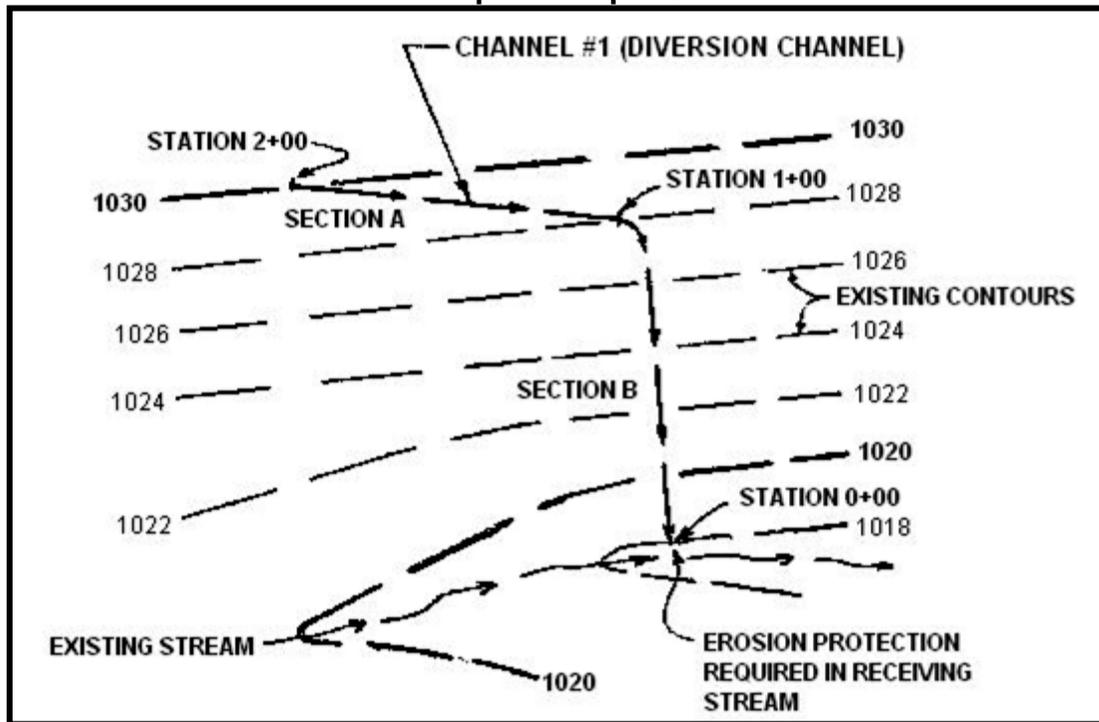
- Where:  $F$  = minimum freeboard in feet  
 $V$  = velocity in fps  
 $D$  = flow depth in feet

For stable flow conditions, the minimum freeboard should be 25% of the flow depth.

**The minimum freeboard for any channel is 6”.**

6. Provide suitable outlet protection for all channels. See outlet protection section of this manual.

**FIGURE 6.3  
Plan Map of Sample Channel**



PA DEP

A 200 foot long temporary channel will be designed. The first 100 feet — measured from the discharge end — will have a bed slope of 10%, while the upper 100 feet will have a 2% slope, as shown in Figure 6.3. Therefore, it will be designed in 2 segments. The gentler upper segment will be “Section A”, and the steeper lower segment will be “Section B.” The soils map on the NRCS website indicates that the channel will be constructed in Guernsey silt loam.

1. **Capacity ( $Q_r$ )** - In this example, the tributary acreage of 9.4 acres is measured from a topographic map. Using 1.6 cfs/acre as the capacity,  $Q_r = 15$  cfs.
2. **Soil Erodibility** - In Table E-1, Guernsey silt loam is listed as “erodible.”
3. **Channel Shape and Initial Dimensions** - A trapezoidal channel with a 2 foot bottom width and 2H:1V side slopes is selected for section A. The channel is checked for the "unlined condition" first for demonstration purposes only, since all diversion channels require a suitable erosion resistant lining. The shear stress method was selected to see if the anticipated shear stress exceeds maximum allowable shear stress. Compute the anticipated shear stress ( $\tau_d$ ):

$$\tau_d = 62.4 d \times s.$$

Where:  $\tau_d$  = shear stress in pounds per square foot  
 $d$  = flow depth in feet  
 $s$  = channel bed slope in feet per foot

The calculated shear stress (0.87 lb/ft<sup>2</sup>) exceeds the maximum allowable shear stress (0.03 lb/ft<sup>2</sup>, see example E&S Worksheet #11). Therefore an unlined channel design would not even be suitable for a channel discharging to a sediment basin or trap.

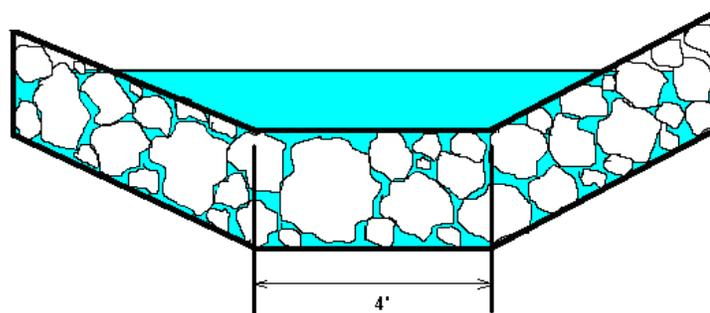


It should be noted that Guernsey silt loam appears on the potential hydric soils list in many counties in Pennsylvania. A determination should also be done to ensure that the channel is not located within a wetland. Tall Fescue tolerates wet soil (Table 11.2). A vegetative lining with Retardance C is checked for adequacy using the allowable velocity method. Its allowable velocity is listed as 5 in Table 6.4. However, note 2 indicates that the maximum velocity should be 3 to 4 fps for channels vegetated by seeding. Since Guernsey is an erodible soil, the maximum velocity is 3 fps which is less than the calculated velocity of 3.2 fps. Therefore, the proposed vegetative lining would not be acceptable without a turf reinforcement mat (TRM) in addition to the vegetation. For this example, a change in bottom width will be used instead. Using a 4.0 bottom width, and a new flow depth of 0.95 feet, a calculated capacity of 14.8 cfs with a velocity of 2.7 fps is obtained. Although the calculated Q is slightly less than the required 15 cfs, the difference is more than accounted for by rounding the total channel depth to the nearest 6". **NOTE: Channel dimensions shown on the plan drawings should be rounded up to the nearest 6" for constructability.**

Since the channel will be seeded, rather than sodded, a temporary liner is required to prevent erosion within the channel until the vegetation becomes established. A curled wood mat with a manufacturer's recommended maximum velocity of 6.0 fps is proposed and checked for adequacy. The value of Manning's "n" taken from Table 6.9 is 0.035 (since the anticipated flow depth is between 0.5' and 2.0'). Since the anticipated velocity (4.4 fps) is less than the maximum permissible, this temporary lining is acceptable.

Due to the steep bed slope (0.10 ft/ft) of Section B, a riprap lining is proposed and should be checked using the shear stress method. For the initial trial, an R-4 liner is proposed. The resulting cross-section is pictured in Figure 6.4. The calculated shear stress is 3.74 lb/ft<sup>2</sup>, too large for R-4 riprap.

**FIGURE 6.4**  
**Void Space in Riprap Channel Bottom**



PA DEP

For R-4 Riprap, the maximum stone size is 12". Since the minimum placement thickness is 1.5 times the maximum stone size, the minimum cross-sectional area of the riprap is 6 sq. ft. on the bottom of the channel. Assuming 40% void space, 2.4 sq. ft. may be subtracted from the cross-sectional area of the water flowing on top of the stone — void spaces on the sides of the channel are ignored. The flow depth above the stone is then adjusted to produce the revised cross-sectional area of the water above the stone ( $3.12 \text{ ft}^2 - 2.40 \text{ ft}^2 = 0.72 \text{ ft}^2$ ). The reduced flow depth results in a shear stress of 1.04 lb/ft<sup>2</sup>, less than the maximum of 2.00 lb/ft<sup>2</sup> for R-4 riprap. Had the result not been favorable, a channel bottom width of 6 feet would have been tried. If still not adequate, an R-5 riprap would have been selected and the process re-started. If no suitable channel bottom width and riprap size can be found, another channel liner should be used. Grouting the riprap is not an effective way of addressing shear stress problems with steep slope riprap channels.

4. **Freeboard** - The flow depth in Section A, at which the required capacity is provided, is essentially the same for the Tall Fescue vegetated condition as for the temporary liner. The minimum total

channel depth for Section A is 1.0' + 0.5', or 1.5'. The temporary liner should extend to the full constructed depth of the channel. Stable flow conditions exist in both Sections A and B, and the anticipated flow depths are less than 24", so the required freeboard is 0.5' for both sections. Thus the minimum total depth of Section A is 1.5' (1.0' calculated flow depth + 0.5' freeboard), and that for Section B is 1.2' (0.7' + 0.5'). **NOTE: For constructability, it is recommended that channel dimensions be specified in 6" increments.** For the example channel, the specified dimensions should show a 1.5' total depth for Sections A and B. However, the riprap lining in Section B, need not extend above 1.0 foot total depth.

Construction - Temporary and permanent channels should be constructed to the dimensions shown on the E&S Plan drawings. **(Note: Channels having riprap, Reno mattress, or gabion linings must be sufficiently over-excavated so that the design dimensions will be provided after placement of the protective lining.)**

Maintenance - Channels should be maintained to ensure that the specified design dimensions and protective linings are available at all times. A channel should be cleaned whenever total channel depth is reduced by 25% at any location. Damaged channel linings should be repaired or replaced immediately.

**Channel #1 (Diversion Channel) on  
WORKSHEET # 11  
CHANNEL DESIGN DATA**

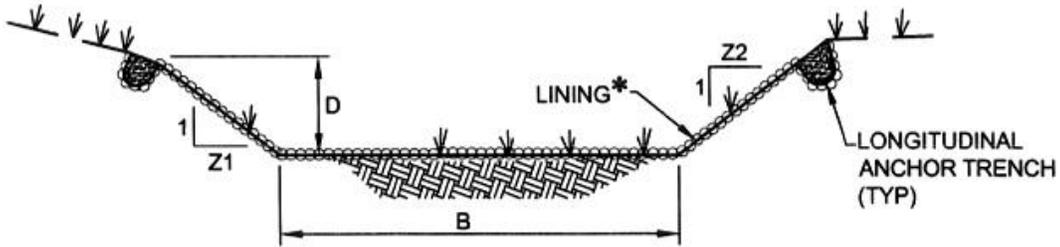
<b>CHANNEL OR CHANNEL SECTION</b>	DC-1A	DC-1A	DC-1A	
<b>Temporary or Permanent</b>	Temp	Temp	Temp	
<b>Design Storm</b>	2-year	2-year	2-year	
<b>Acres</b>	9.4	9.4	9.4	
<b>Multiplier (1.6, 2.25, or 2.75)</b>	1.6	1.6	1.6	
<b>Q<sub>r</sub> (REQUIRED CAPACITY) CFS</b>	15.0	15.0	15.0	
<b>Q (CALCULATED AT FLOW DEPTH d) CFS</b>	15.0	17.4	14.8	
<b>PROTECTIVE LINING</b>	Unlined	Curled Wood Mat	Tall Fescue	
<b>V<sub>a</sub> (ALLOWABLE VELOCITY) FPS</b>	N/A	6.0	3	
<b>V (CALCULATED AT FLOW DEPTH d) FPS</b>	6.3	4.4	2.7	
<b>τ<sub>a</sub> (MAX ALLOWABLE SHEAR STRESS) LB/FT<sup>2</sup></b>	0.03	N/A	N/A	
<b>τ<sub>d</sub> (SHEAR STRESS @ FLOW DEPTH d) LB/FT<sup>2</sup></b>	0.87	N/A	N/A	
<b>CHANNEL BOTTOM WIDTH (FT)</b>	2.0	2.0	4.0	
<b>CHANNEL SIDE SLOPES (H:V)</b>	2:1	2:1	2:1	
<b>D (TOTAL DEPTH) FT</b>	1.2	1.5	1.5	
<b>CHANNEL TOP WIDTH @ D (FT)</b>	6.8	8.0	9.8	
<b>d (CALCULATED FLOW DEPTH) FT</b>	0.7	1.0	0.95	
<b>CHANNEL TOP WIDTH @ FLOW DEPTH d (FT)</b>	4.8	6.0	7.8	
<b>BOTTOM WIDTH: FLOW DEPTH RATIO (12:1 MAX)</b>	2.9	2.0	4.2	
<b>d<sub>50</sub> STONE SIZE (IN)</b>	N/A	N/A	N/A	
<b>A (CROSS-SECTIONAL AREA IN SQ. FT.)</b>	2.38	4.0	5.61	
<b>n (MANNING'S COEFFICIENT)</b>	0.02	0.035	0.06	
<b>R (HYDRAULIC RADIUS)</b>	0.46	0.62	0.68	
<b>S (BED SLOPE, FT/FT)</b>	0.02	0.02	0.02	
<b>S<sub>c</sub> (CRITICAL SLOPE)</b>	0.008	0.023	0.063	
<b>.7S<sub>c</sub></b>	0.006	0.016	0.044	
<b>1.3S<sub>c</sub></b>	0.010	0.016	0.082	
<b>STABLE FLOW? (Y/N)</b>	Y	N	Y	
<b>FREEBOARD BASED ON UNSTABLE FLOW FT</b>	N/A	0.3	N/A	
<b>FREEBOARD BASED ON STABLE FLOW FT</b>	0.2	N/A	0.5	
<b>MINIMUM REQUIRED FREEBOARD FT</b>	0.5	0.5	0.5	
<b>DESIGN METHOD FOR PROTECTIVE LINING PERMISSIBLE VELOCITY (V) OR SHEAR STRESS (S)</b>	S	V	V	

**Channel #1 (Diversion Channel) on  
WORKSHEET # 11  
CHANNEL DESIGN DATA (CONTINUED)**

<b>CHANNEL OR CHANNEL SECTION</b>	DC-1B	DC-1B		
<b>Temporary or Permanent</b>	Temp	Temp		
<b>Design Storm</b>	2-year	2-year		
<b>Acres</b>	9.4	9.4		
<b>Multiplier (1.6, 2.25, or 2.75)</b>	1.6	1.6		
<b>Q<sub>r</sub> (REQUIRED CAPACITY) CFS</b>	15.0	15.0		
<b>Q (CALCULATED AT FLOW DEPTH d) CFS</b>	15.1	-		
<b>PROTECTIVE LINING</b>	R-4	R-4		
<b>V<sub>a</sub> (ALLOWABLE VELOCITY) FPS</b>	N/A	N/A		
<b>V (CALCULATED AT FLOW DEPTH d) FPS</b>	4.8	-		
<b>τ<sub>a</sub> (MAX ALLOWABLE SHEAR STRESS) LB/FT<sup>2</sup></b>	2.00	2.00		
<b>τ<sub>d</sub> (SHEAR STRESS @ FLOW DEPTH d) LB/FT<sup>2</sup></b>	3.74	1.04		
<b>CHANNEL BOTTOM WIDTH (FT)</b>	4.0	4.0		
<b>CHANNEL SIDE SLOPES (H:V)</b>	2:1	2:1		
<b>D (TOTAL DEPTH) FT</b>	1.1	-		
<b>CHANNEL TOP WIDTH @ D (FT)</b>	8.4	-		
<b>d (CALCULATED FLOW DEPTH) FT</b>	0.600	0.167		
<b>CHANNEL TOP WIDTH @ FLOW DEPTH d</b>	6.4	-		
<b>BOTTOM WIDTH: FLOW DEPTH RATIO (12:1 MAX)</b>	6.7	-		
<b>d<sub>50</sub> STONE SIZE (IN)</b>	6	6		
<b>A (CROSS-SECTIONAL AREA IN SQ. FT.)</b>	3.12	0.72		
<b>n (MANNING'S COEFFICIENT)</b>	0.058	-		
<b>R (HYDRAULIC RADIUS)</b>	0.47	-		
<b>S (BED SLOPE, FT/FT)</b>	0.10	-		
<b>S<sub>c</sub> (CRITICAL SLOPE)</b>	0.067	-		
<b>.7S<sub>c</sub></b>	0.047	-		
<b>1.3S<sub>c</sub></b>	0.087	-		
<b>STABLE FLOW? (Y/N)</b>	Y	-		
<b>FREEBOARD BASED ON UNSTABLE FLOW FT</b>	N/A	N/A		
<b>FREEBOARD BASED ON STABLE FLOW FT</b>	0.2	-		
<b>MINIMUM REQUIRED FREEBOARD FT</b>	0.5	-		
<b>DESIGN METHOD FOR PROTECTIVE LINING PERMISSIBLE VELOCITY (V) OR SHEAR STRESS (S)</b>	S	S		

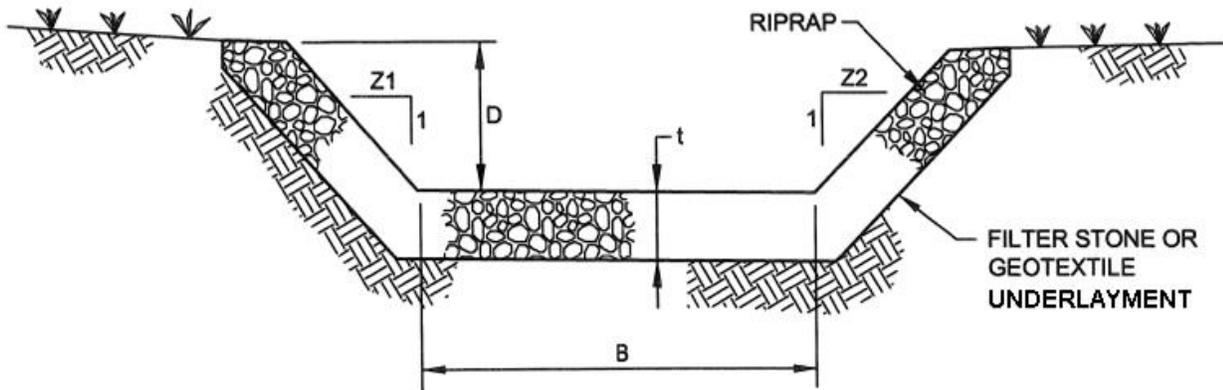
NOTE: Unsuccessful trials are shown here for illustration. Only the successful trial should be included in the calculations submitted as part of the E&S plan narrative.

**Channel #1 Segments "A" and "B"**  
**On Tables from Standard Construction Details 6-1 and 6-3**



NOTE: This table is intentionally blank and should be filled in by the plan preparer.

Channel	Stations	B	D	Z1	Z2	Lining
DC-1A	1+00 to 2+00	2.0	2.5	2.0	2.0	Grass/Curled Wood Mat

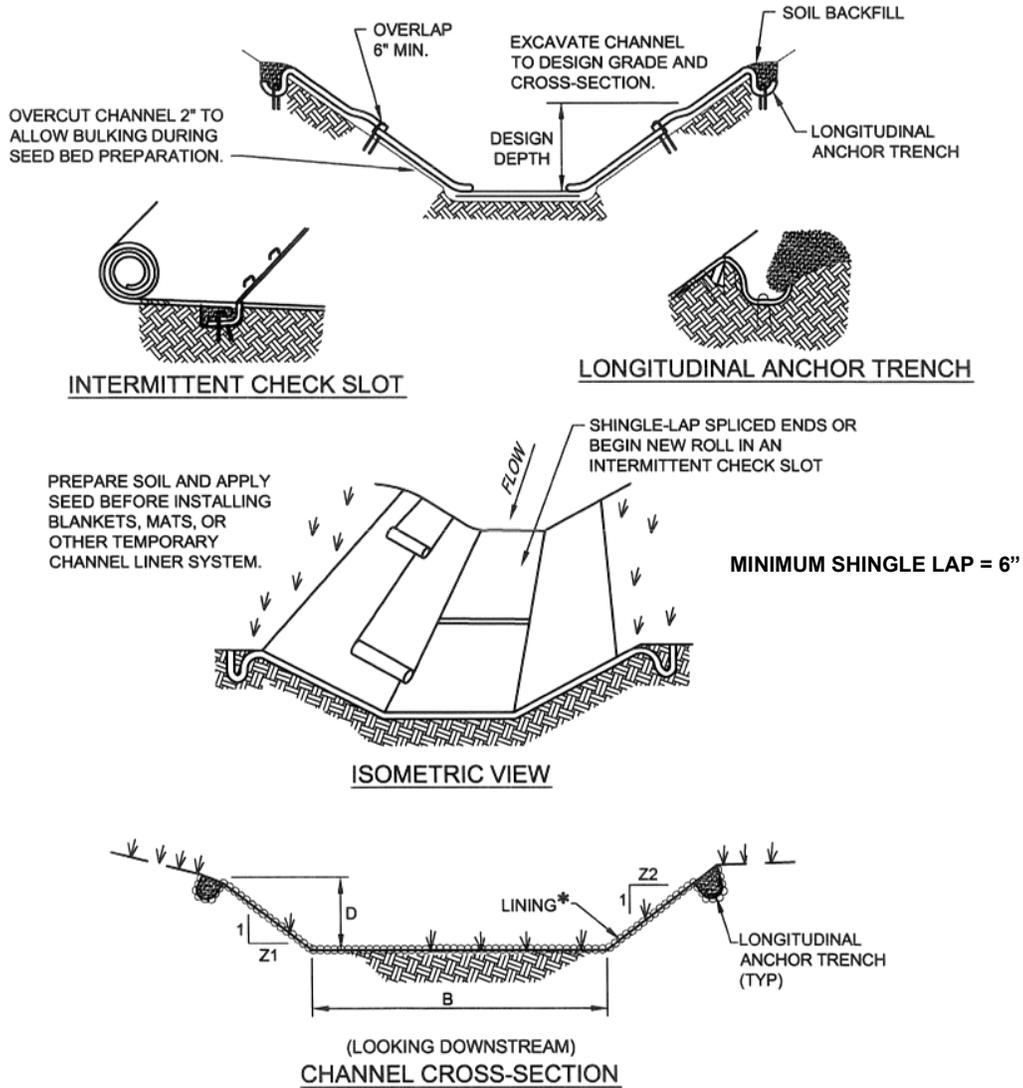


**(LOOKING DOWNSTREAM)**  
**CHANNEL CROSS-SECTION**

NOTE: This table is intentionally blank and should be filled in by the plan preparer.

Channel	Stations	B	D	Z1	Z2	Riprap Gradation	t	Underlayment	Underlayment Thickness
DC-1B	0+00 to 1+00	4.0	1.5	2	2	R-5	27"	AASHTO #3	6"

## STANDARD CONSTRUCTION DETAIL # 6-1 Vegetated Channel



\* SEE MANUFACTURER'S LINING INSTALLATION DETAIL FOR STAPLE PATTERNS, AND VEGETATIVE STABILIZATION SPECIFICATIONS FOR SOIL AMENDMENTS, SEED MIXTURES AND MULCHING INFORMATION.

Adapted from Salix Applied Earthcare - Erosion Draw 5.0

NOTE: This table is intentionally blank and should be filled in by the plan preparer.

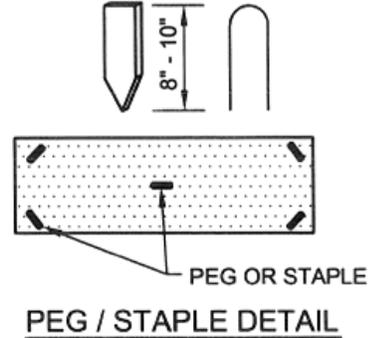
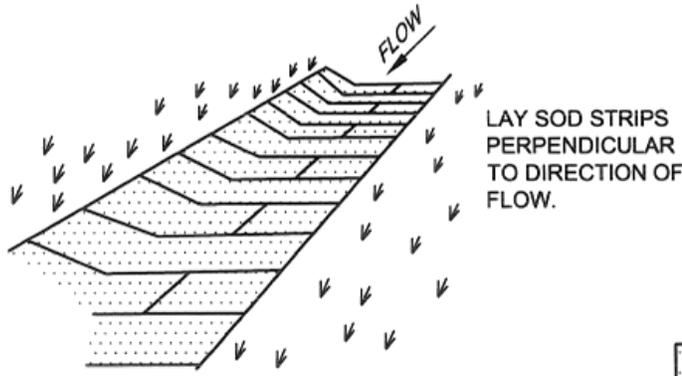
CHANNEL NO.	STATIONS	BOTTOM WIDTH B (FT)	DEPTH D (FT)	TOP WIDTH W (FT)	Z1 (FT)	Z2 (FT)	LINING*

Anchor trenches shall be installed at beginning and end of channel in the same manner as longitudinal anchor trenches.

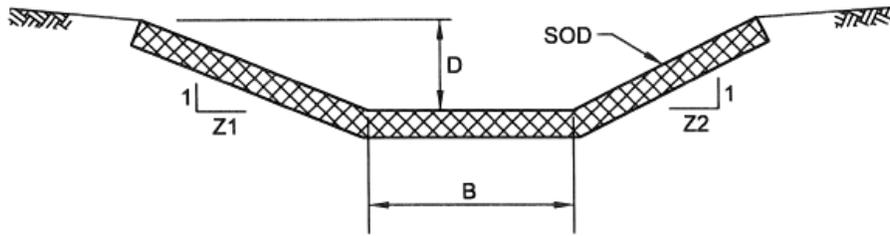
Channel dimensions shall be constantly maintained. Channel shall be cleaned whenever total channel depth is reduced by 25% at any location. Sediment deposits shall be removed within 24 hours of discovery or as soon as soil conditions permit access to channel without further damage. Damaged lining shall be repaired or replaced within 48 hours of discovery.

**No more than one third of the shoot (grass leaf) shall be removed in any mowing. Grass height shall be maintained between 2 and 3 inches unless otherwise specified. Excess vegetation shall be removed from permanent channels to ensure sufficient channel capacity.**

**STANDARD CONSTRUCTION DETAIL #6-2  
Sodded Channel**



- NOTES:**
1. USE PEGS OR STAPLES TO FASTEN SOD FIRMLY AT THE END OF STRIPS AND IN THE CENTER, OR EVERY 3' - 4' IF THE STRIPS ARE LONG. WHEN READY TO MOW, DRIVE PEGS OR STAPLES FLUSH WITH THE GROUND.
  2. IN CRITICAL AREAS, SECURE SOD WITH STAPLED NETTING.



CHANNEL CROSS-SECTION

Adapted from VA DSWC

NOTE: This table is intentionally blank and should be filled in by the plan preparer.

CHANNEL NO.	STATIONS	BOTTOM WIDTH B (FT)	DEPTH D (FT)	TOP WIDTH W (FT)	Z1 (FT)	Z2 (FT)

Care shall be taken to prepare the soil adequately prior to sod placement. Plant species shall be suitable for the anticipated peak flow velocity.

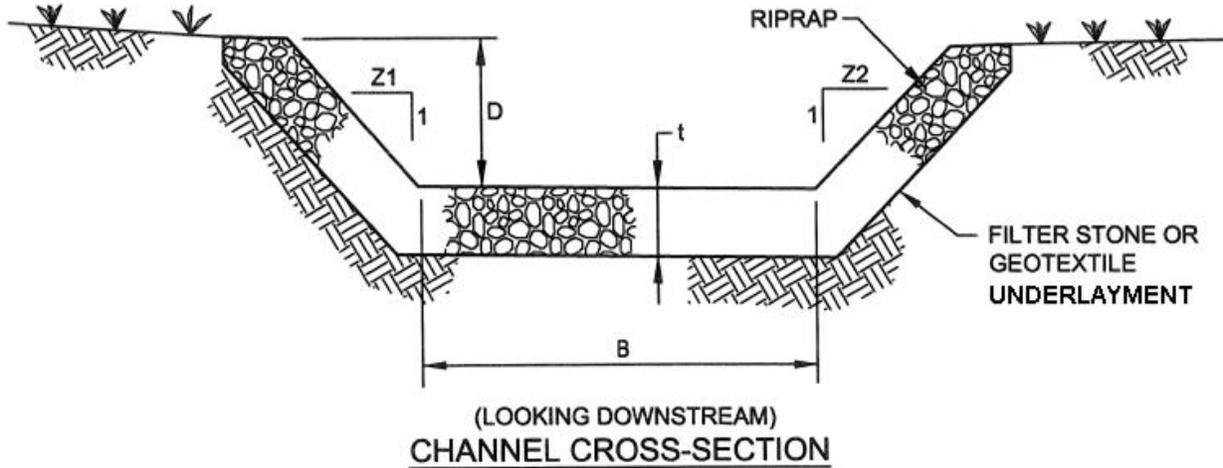
During 2 to 3 week establishment stage, sod shall be watered as necessary to maintain adequate moisture in the root zone and prevent dormancy of sod.

Channel dimensions shall be constantly maintained. Channel shall be cleaned whenever total channel depth is reduced by 25% at any location. Sediment deposits shall be removed within 24 hours of discovery or as soon as soil conditions permit access to channel without further damage. Damaged lining shall be repaired or replaced within 48 hours of discovery.

No more than one third of the shoot (grass leaf) shall be removed in any mowing. Grass height shall be maintained between 2 and 3 inches unless otherwise specified. Excess vegetation shall be removed from permanent channels to ensure sufficient channel capacity.



**STANDARD CONSTRUCTION DETAIL # 6-3  
RIPRAP CHANNEL**



Stackhouse Bensinger, Inc.

NOTE: This table is intentionally blank and should be filled in by the plan preparer.

Channel	Stations	B	D	Z1	Z2	Riprap Gradation	t	Underlayment	Underlayment Thickness

Filter stone underlayment for bed slopes  $\geq 0.10$  ft/ft shall be used.

Channel dimensions are for the completed channel after rock placement. Channel must be over-excavated a sufficient amount to allow for the volume of rock placed within the channel while providing the specified finished dimensions.

Channel dimensions shall be constantly maintained. Channel shall be cleaned whenever total channel depth is reduced by 25% at any location. Sediment deposits shall be removed within 24 hours of discovery or as soon as soil conditions permit access to channel without further damage.

Damaged lining shall be repaired or replaced within 48 hours of discovery.

The minimum rock thickness (t) shall be 1.5 times the max rock size.

## BERM

Berms may be used in a similar manner to channels so long as flow can be maintained along the upslope side of the berm. The maximum tributary area to a berm should be 5.0 acres unless otherwise permitted by the reviewing agency. Objectionable materials should be removed from the berm alignment prior to construction. All berms must be properly compacted. Other design criteria for berms are the same as for channels.

### TOP-OF-SLOPE BERM

Top-of-slope berms are typically used to prevent runoff from running over the edge of a fill and causing erosion on the fill slope. Berms capture runoff from the top of the fill and convey it to a temporary slope pipe or groin ditch leading to a collector channel, sediment trap or sediment basin.

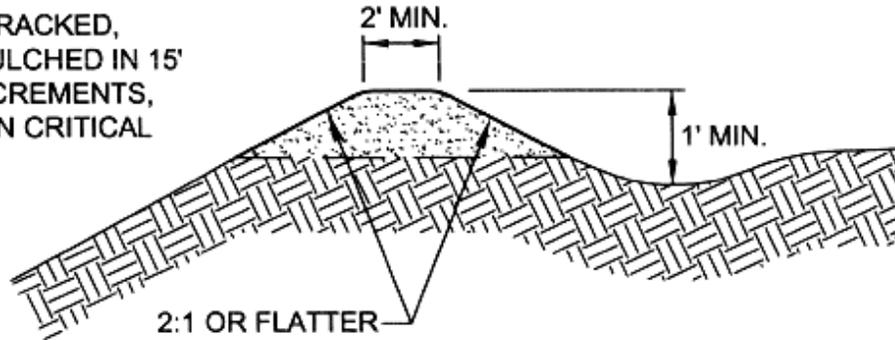


PA DEP

Top-of-slope berms should be maintained with successive lifts (See Figure 6.5). As a fill is being constructed, the berm should be raised prior to placement of the next fill lift.

**STANDARD CONSTRUCTION DETAIL # 6-4  
Top-of-Slope Berm**

FILL SLOPE TRACKED,  
SEEDED & MULCHED IN 15'  
VERTICAL INCREMENTS,  
BLANKETED IN CRITICAL  
AREAS



Adapted from North Carolina DENR

**Temporary berms shall be placed, maintained, and adjusted continuously until 90% vegetative growth is established on the exterior slopes with permanent storm drainage facilities functioning.**

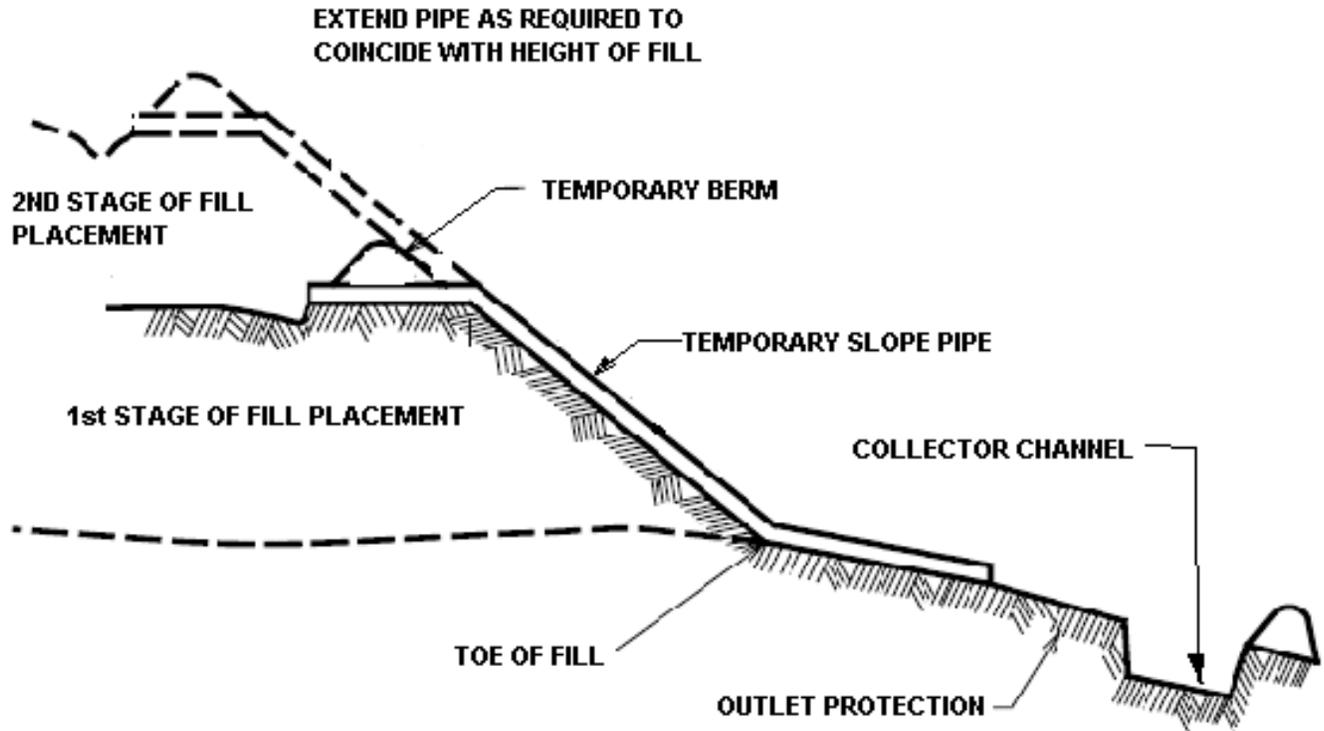
**Berms shall outlet to slope pipes, channels, or other approved means of conveying runoff to a sediment trap, sediment basin, or collector channel.**

**Channel behind berm shall have positive grade to outlet and an appropriate protective lining.**

**Berm shall be adequately compacted to prevent failure.**

**An acceptable alternative to top-of-slope berm is to continuously grade the top of fill to direct runoff away from the fillslope to a collector channel, sediment trap, or sediment basin.**

**FIGURE 6.5**  
**Maintaining Top-of-slope Berms and Temporary Slope Pipes**



Adapted from West Virginia DEP

Slope pipe outlet should be oriented so that the discharge enters the receiving channel at less than 90 degrees. Provide a thrust block to prevent separation of slope pipe sections due to the angled discharge.

TEMPORARY SLOPE PIPE - Temporary slope pipes, also called temporary slope drains or pipe slope drains, are flexible conduits for conveying runoff down existing or constructed steep slopes. Wherever they are used to convey discharges from sediment basins or traps, they should be connected to the principal spillway outlet barrel. When used to convey runoff from unstabilized areas, they should discharge to a sediment basin, trap, or collector channel. The end of a pipe discharging to a collector channel should be oriented to facilitate flow in the channel and located so as to avoid obstructing flow from any upgradient section of the channel.



York County Conservation District

Add outlet protection as needed to avoid erosion to downstream areas.

Temporary slope pipes should have sufficient capacity to convey the anticipated peak flow from the design storm. Suggested minimum pipe diameter and minimum berm heights are given in Table 6.11.

The maximum tributary drainage area for use of Table 6.11 is 5 acres. Supporting calculations showing sufficient capacity should be provided for slope pipes with drainage areas greater than 5 acres.

The entrance should have a flared end section with a 6" toe plate, which is firmly entrenched.

The pipe should consist of heavy-duty flexible pipe or corrugated metal and should be securely staked to the slope. The maximum distance between stakes should be 10 feet.

All connections should be watertight.

Temporary slope pipes should be installed according to the details shown in Standard Construction Detail # 6-5.

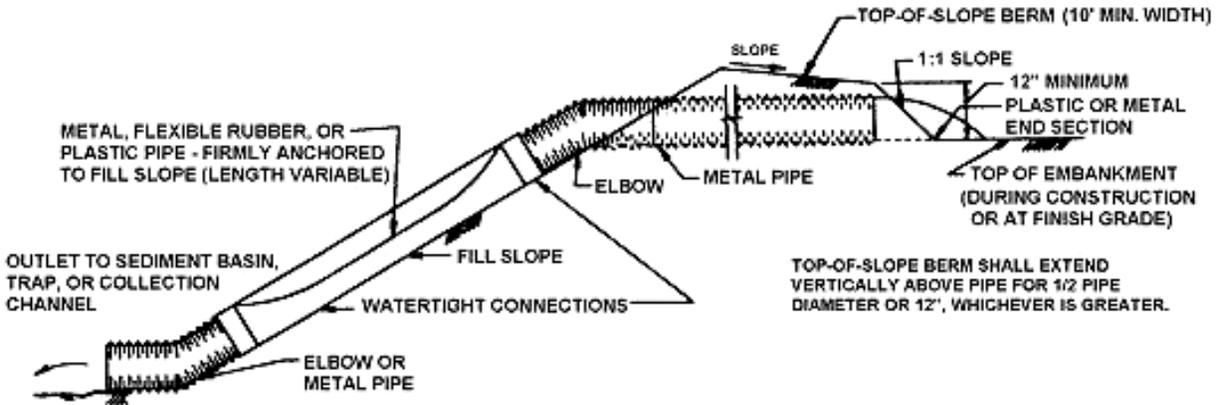
Temporary slope pipes should be inspected on a weekly basis and after each runoff event. Any accumulated sediment should be removed from the entrance. Damaged pipe should be repaired or replaced. Needed repairs should be initiated immediately after the inspection.

**TABLE 6.11**  
**Minimum Dimensions for Temporary Slope Pipes**

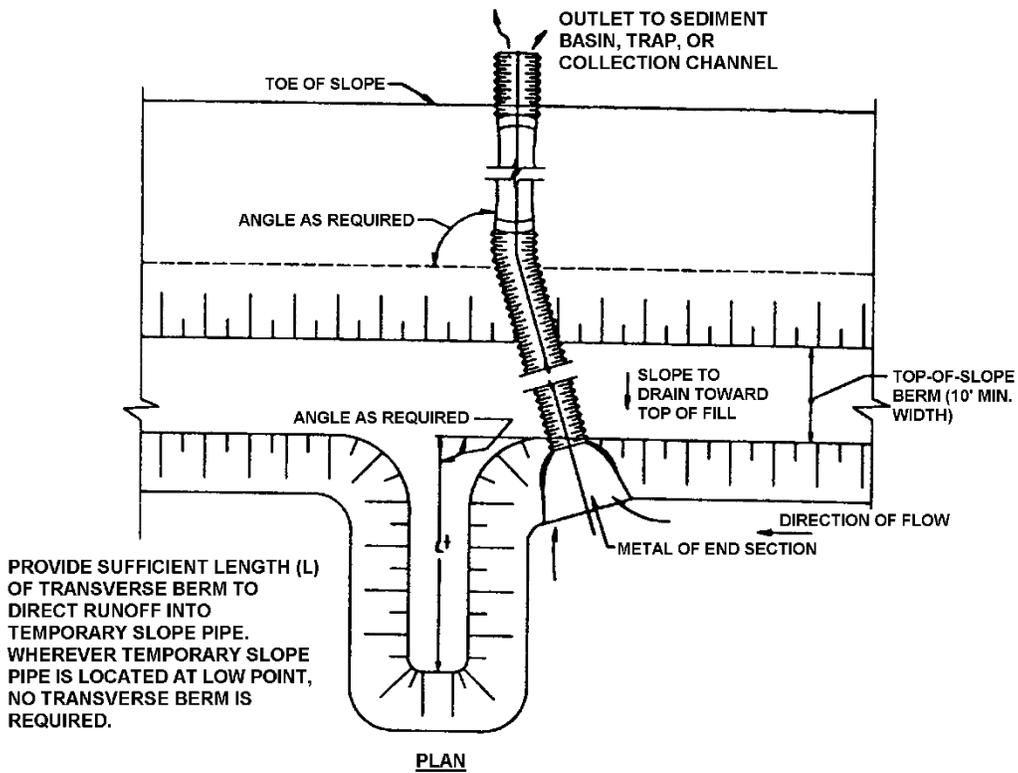
<b>Drainage Area (Acres)</b>	<b>Minimum Pipe Diameter (in.)</b>	<b>Minimum Berm Height (in.)</b>
<2	12	24
2 - 4	15	27
4 - 5	18	30

Adapted from U.S. EPA Stormwater BMPs and *Urban Drainage and Flood Control District*, 1999

## STANDARD CONSTRUCTION DETAIL # 6-5 Temporary Slope Pipe



### SLOPE PIPE WITH TRANSVERSE BERM



Adapted from PennDOT RC70, April 2004

NOTE: This table is intentionally blank and should be filled in by the plan preparer.

Slope Pipe No.	Outlet Protection Type	R-size or Material	Apron Length (ft)	Apron Width (ft)

The maximum distance between anchor stakes shall be 10 feet.

Transverse berm shall be used whenever temporary slope pipe is not located at low point.

Slope pipes shall be inspected weekly and after each runoff event. Any accumulated sediment shall be removed from the inlet immediately.

**Damaged pipe sections shall be replaced within 24 hours. Leaking connections shall be repaired immediately.**



**BENCH** - Benches (a.k.a. gradient terraces) are recommended to break up long fill or cut slopes and convey runoff to one or both sides. For slopes on soils having low shear strength, care should be taken to prevent saturation of the soil and/or bedrock below the bench.



York County Conservation District

Benches should be constructed to the minimum dimensions shown in Standard Construction Detail # 6-6. They should have a minimum longitudinal drainage slope of 2% and a maximum slope of 5%.

Wherever soil conditions and/or anticipated flow conditions indicate a significant potential for erosion of the bench, a suitable protective liner should be provided. Please refer to channel design text or manufacturer's recommendations for guidance on selection of protective linings.

Bench lengths should not exceed 800 feet in one flow direction. Where equipment is likely to use the bench as a travelway, as done at landfills, rock lining is recommended.

Maximum vertical spacing between benches should not exceed those shown in Table 6.12.

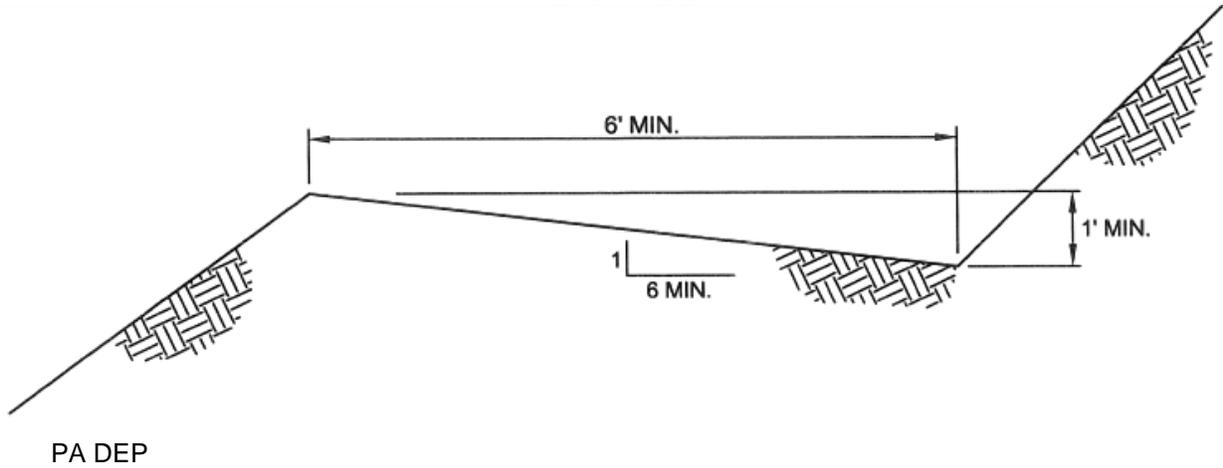
**TABLE 6.12  
Bench Spacing**

Slope	Maximum Vertical Spacing Between Benches (Ft.)	
	Steep Slopes	Long Slopes
2H:1V	20	50
3H:1V	35	80
4H:1V	45	125
15 - 25%	50	200
10 - 15%	80	300
6 - 10 %	125	
3 - 6%	200	
<3%	300	

North Carolina DENR

Benches should discharge to adequately sized and protected conveyance facilities (e.g. storm sewers, groin ditches etc.).

**STANDARD CONSTRUCTION DETAIL # 6-6  
Bench Detail**



**Benches shall be inspected on a weekly basis and after each runoff event.**

**Benches shall be maintained to design dimensions at all times.**

**Needed repairs shall be initiated immediately after the inspection.**

## CHAPTER 7 - SEDIMENT BASINS

### DESIGN CRITERIA SUMMARY

1. Sediment basins may not be located within the drainage area of a sediment trap or another sediment basin (unless the sediment basins are integral to the permanent stormwater design and are properly sized for storage and discharge capacities). Sediment basins also may not be located within a live stream channel, or a wetland. The bottom elevation should not be located below the seasonal high water table, adjacent wetlands, or perennial stream channels. Unanticipated springs and seeps intercepted during excavation should be safely conveyed around the basin to a suitable down gradient discharge point.
2. In karst topography, impounded water causes soil saturation and loss of cohesion, and produces stress from the weight of the water. Differences in hydraulic head and steep hydraulic gradients can result in sinkhole development. To ensure that these facilities are kept small and shallow, it is recommended that drainage areas be kept to 5 acres or less and that sediment traps be utilized to the maximum extent practicable so that the total depth is kept below 5 feet (see Chapter 8 – Sediment Traps for more information). For areas where a sediment basin cannot be avoided, the designer should keep the depth to the minimum (4 feet to the top of the settling volume). At the discretion of the designer, it may be necessary to install an impermeable liner based on geotechnical testing, known occurrences of sinkhole development, and whether the basin will be converted to a permanent stormwater management facility. Maintenance instructions should emphasize the importance of ensuring the integrity of all pipes. Pipe leakage or sagging can become the focus of soil loss into subsurface voids leading to subsidence and the development of sinkholes. Should sinkholes develop, they should be promptly and properly repaired. Please see Chapter 17, Areas of Special Concern, for information regarding sinkhole repair. Information regarding sinkhole repair should be placed on the plan drawings.
3. Access to proposed and existing basins should be provided in accordance with the standards provided in Chapter 3. Such accesses should be maintained for the life of the basin. When no longer needed, accesses should be regraded and stabilized in accordance with Chapter 11.
4. Permanent basins which are used temporarily as sediment basins must be designed to meet the requirements of the permanent basin (e.g. inside and outside slopes, permanent outlet structures, benches, forebays, access ramps, and preservation/remediation of subsoils for infiltration rates). Sediment basins that will be converted to infiltration basins should be constructed in accordance with the Pennsylvania Stormwater Best Management Practices Manual or other appropriate design standard at the discretion of the Department. Note that the risk of infiltration failure may increase significantly for infiltration basins used as sediment basins during construction.
5. A sediment storage zone of 1,000 cubic feet per disturbed acre — over the life of the project within the watershed of the basin is required. The sediment storage zone should be at least 1 foot in depth. This zone is in addition to any permanent pool requirement.
6. A dewatering zone of 5,000 cubic feet for each disturbed and undisturbed acre disturbed and undisturbed tributary to the basin is also to be provided. Reductions in the dewatering zone are allowed unless the basin is in an HQ or EV watershed. However, the minimum required dewatering zone in non-special protection watersheds is 3,600 cubic feet per acre. The minimum depth of the dewatering zone is 3 feet.

7. Greater surface areas increase trapping efficiency of sediment basins. The recommended minimum surface area ( $SA_{min}$ ) at the top of the settling volume is:

$$SA_{min} = 1.2 (q_{out} / v_s), \text{ where:}$$

$q_{out}$  = basin discharge rate at elevation 3 on E&S Worksheet #15.

$v_s$  = Particle settling velocity as follows:

For sand, loamy sand, & sandy loam soils:  $v_s = 1.2 \times 10^{-3}$  ft/sec

For loam, silt, & silt loam soils:  $v_s = 7.3 \times 10^{-5}$  ft/sec

For clay loam, silty clay, & clay soils:  $v_s = 1.2 \times 10^{-5}$  ft/sec

An acceptable alternative is the use of a soil stabilizer on disturbed surfaces to reduce sediment load in runoff.

8. Sediment basins should have a flow length to width ratio of at least 2L:1W unless a turbidity barrier or a suitable sediment forebay is provided. For sizing and shaping of forebays, see Pennsylvania Stormwater Best Management Practices Manual. Forebays should be cleaned when accumulated sediment reaches half the total depth. In special protection watersheds a 4L:1W flow length to width ratio should be provided.
9. Sediment basins should dewater in a period ranging from 2 to 7 days (4 to 7 days in special protection watersheds). Skimmers are the preferred dewatering devices; however, perforated risers are also acceptable. For perforated risers, sediment removal efficiency can be increased, particularly for the smaller storm events, by providing a less proportional amount of perforations on the bottom row (or two for risers having 5 or more rows of holes) of the riser. Unless otherwise approved, there should be no more than 2 holes difference between upper and lower rows. The “rule of thumb” for dewatering time calculations of perforated risers may not be used on risers designed in this way
10. Every sediment basin should be provided with an emergency spillway with a minimum bottom width of 8'. Emergency spillways not designed to convey part of the required discharge capacity should have a minimum depth of 6". All others should have sufficient depth to convey the design discharge while providing the required freeboard above the elevation at which the design discharge is provided.
11. The elevation of the emergency spillway crest should be at least 6" above that of the principal spillway — top of dewatering zone.
12. Sediment basin spillways should be able to discharge at least 2 cfs/acre from the entire contributing watershed or route the anticipated peak flow from the 25-year, 24-hour storm event, assuming all dewatering perforations are clogged and standing water not encroaching upon the required freeboard. Discharge capacity may be provided by the principal spillway, or a combination of the principal and emergency spillways. At a minimum, the principal spillway should be designed to convey the calculated peak flow from a 10-year, 24-hour storm event. Spillways of permanent basins used as temporary sediment basins may require greater discharge capacities.
13. Outlet barrels for permanent basins — and temporary basins with tributary drainage areas of 10 acres or more — should be set in a concrete cradle, as shown in Standard Construction Detail #7-17. Outlet barrels should be constructed of a material that is not susceptible to crushing or other damage during construction. Limitations of piping are often given by the manufacturer. PVC and other materials requiring gravel enclosures to prevent crushing are not acceptable for use as outlet barrels. Anti-seep collars or filter diaphragms should be provided wherever soils having piping potential (see Table E-1) are used to construct the embankment.

14. The discharge from a sediment basin should be safely conveyed to a surface water or adequately sized storm sewer. Where an outlet channel extending between a sediment basin and a receiving stream is proposed, it should be designed to safely convey the same flow which is computed to discharge from the basin. The design flow for the outlet channel would depend upon a number of factors:
  - A. If a portion of the discharge from the sediment basin is being diverted into another conveyance system that is not interconnected (e.g. storm sewer), then that portion should be subtracted from the design flow for the outlet channel. In these instances, approval would be needed from the owner of that sewer system. Consideration for impacts to receiving waters may also be necessary for the destination point of the diverted flow. .
  - B. For sediment basins that will be converted to permanent basins, the outlet channels should be designed for the maximum anticipated flows, which could be either the discharge from construction or post-construction conditions (e.g. 2 cfs/acre discharge or 100-year discharge, respectively).
  - C. For sediment basins used solely for temporary purposes, the designer may use either the 2 cfs/acre discharge or the routed 25-year, 24-hour storm.
15. An analysis of the proposed discharge should be conducted in the following instances to demonstrate that no accelerated erosion or damage from stormwater will occur:
  - A. Wherever the discharge from a permanent or temporary basin is to a flow path other than a surface water (e.g. a natural swale).
  - B. Wherever the tributary drainage area of a temporary basin is at least 10% greater than the preconstruction condition.
  - C. Wherever discharges increase peak flow — up to the 100-year event— in a surface water by more than 10%, or as required by the Department.

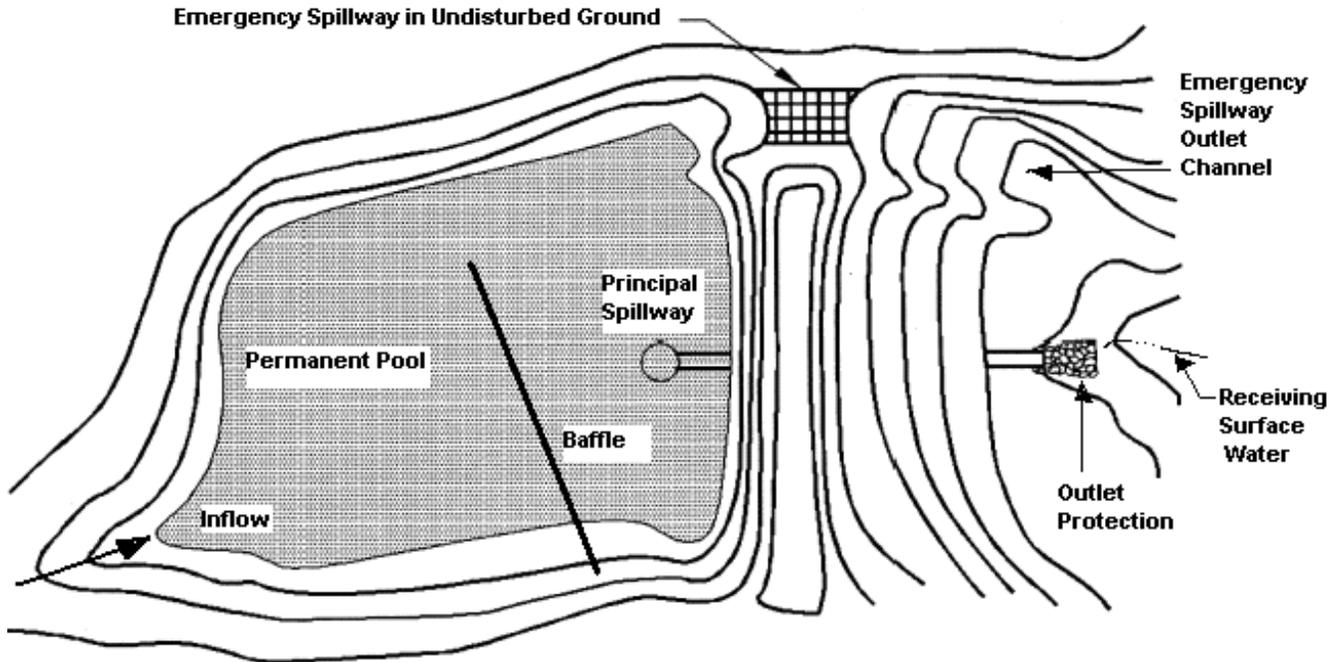
The analysis should follow the sequence of bulleted and numbered items listed in the Department's factsheet on off-site discharges (Off-Site Discharges of Stormwater to Areas That Are Not Surface Waters, Document #3930-FS-DEP4124). Storm frequency may vary on a site to site basis and whether it is a temporary or permanent discharge, but at a minimum, the effects of the 10-year, 24-hour storm should be analyzed.

The first step in the analysis is to show no increase in discharge rate from pre-construction to post-construction conditions. If this is not possible, the flow path below the basin should be analyzed to determine whether accelerated erosion is likely to occur, based upon the calculated peak flow from the 10-year, 24-hour storm event. A written analysis that evaluates and identifies existing land cover and vegetation, topography, geology, and soils on down slope properties should be included. The analysis should be done at the point most vulnerable to erosion (e.g. steepest slope, erodible soil, least protective cover, etc.) between the point of discharge and the receiving surface water. For relatively uniform or extremely long flow paths, a point within 500 feet of the discharge point may be chosen. For discharges increasing the flow rate onto a neighboring property prior to entering a surface water, an easement should be obtained.

16. Soils acceptable for embankment construction should be limited to GC, GM, SC, SM, CL or ML as described in ASTM D-2487 (Unified Soils Classification). Other soils may be acceptable on a case-by-case basis for temporary basins, or permanent basins with drainage areas less than 10 acres.
17. The foundation of the embankment should be stripped and grubbed to a depth of two feet prior to any placement and compaction of earthen fill.

18. A key trench, or cutoff trench, is recommended for all basin embankments with heights exceeding 8 feet and is required for all permanent basins. Minimum trench depth = 2', minimum width = 4', maximum side slope steepness is 1H:1V. The trench should extend up both abutments to the riser crest elevation. Compaction requirements should be the same as those for the embankment. The trench should be dewatered during backfilling and compaction operations. NOTE: A key trench may not be required wherever it can be shown that another design feature, such as the use of an impermeable liner, accomplishes the same purpose.
19. Any springs encountered in the foundation area of a basin embankment should be drained to the outside/downstream toe of the embankment with a drain section two feet by two feet in dimension consisting of PennDOT Type A sand, compacted by hand tamper. No geotextiles are to be used around the sand. The last three feet of this drain at the outside/downstream slope should be constructed with AASHTO #8 material. Other methods of draining spring discharges may be accepted on a case-by-case basis.
20. All basin embankments should be compacted by sheepsfoot or pad roller. The loose lift thickness should be 9 inches or less, depending on roller size, and the maximum particle size is 6 inches or less — 2/3 lift thickness. Five passes of the compaction equipment over the entire surface of each lift is required. Embankment compaction to visible non-movement is also required.
21. The minimum embankment top width is 8 feet. The maximum constructed embankment slope is 2H:1V. The sum of the horizontal components of the inside and outside embankment slopes ( $Z_1 + Z_2$ ) should total at least 5. **The maximum steepness of slopes for constructed embankments in permanent basins is 3H:1V inside and outside.** Embankments and other disturbed areas in and around the basin should be stabilized immediately upon completion of the basin. Trees may not be planted on any basin embankment, because the root systems may compromise the integrity of the berm over time. Trees may be planted in the non-embankment (pool) areas of permanent basins.
22. A minimum of 24 inches of freeboard is required above the elevation at which the 2 cfs/acre discharge capacity or the routed peak flow from the 25-year, 24-hour storm is provided. If the emergency spillway is being used to provide part of the design discharge, the freeboard should be provided above the design flow elevation in the emergency spillway. An acceptable alternative is to provide a discharge capacity equal to the 100-year, 24-hour storm event, assuming maximum runoff conditions, with 12 inches of freeboard.
23. All exposed embankment slopes should be limed, fertilized, seeded and mulched. Permanent vegetative ground cover in compliance with 25 Pa. Code § 102.22 (relating to site stabilization) should be established upon completion of basin construction. Outside slopes should be blanketed.
24. Embankments should be maintained with a grassy vegetative cover, free of brush and trees.
25. When a perforated riser is selected as the means to dewater a temporary sediment basin as shown in Standard Construction Details # 7-6 and # 7-7, the diameter of the riser should be at least 1.25 times that of the outlet barrel. The minimum riser diameter is 15". The minimum barrel diameter is 12".
26. In those instances when a sediment basin will be later used as a stormwater management pond, a temporary riser may be attached to the permanent riser to dewater the dewatering zone within the required time period while the basin is acting as a sediment basin. The diameter of a temporary riser attached to a permanent riser need not be 1.25 times that of the permanent outlet barrel. An acceptable means of using a temporary riser in conjunction with a permanent riser is shown in Standard Construction Detail # 7-9. Temporary dewatering holes may also be drilled into the permanent riser — with permanent orifices temporarily sealed — instead of attaching a temporary riser to the permanent riser. For this option, the same number of holes, rows and vertical spacing with the same size of holes and elevations of the rows should be used as would have been used on the temporary riser. It should be noted that storm sewer inlets tributary to such a basin should be maintained at elevations above the crest of the embankment while the basin is functioning as a sediment basin to prevent flooding of streets.

**FIGURE 7.1  
Sediment Basin**

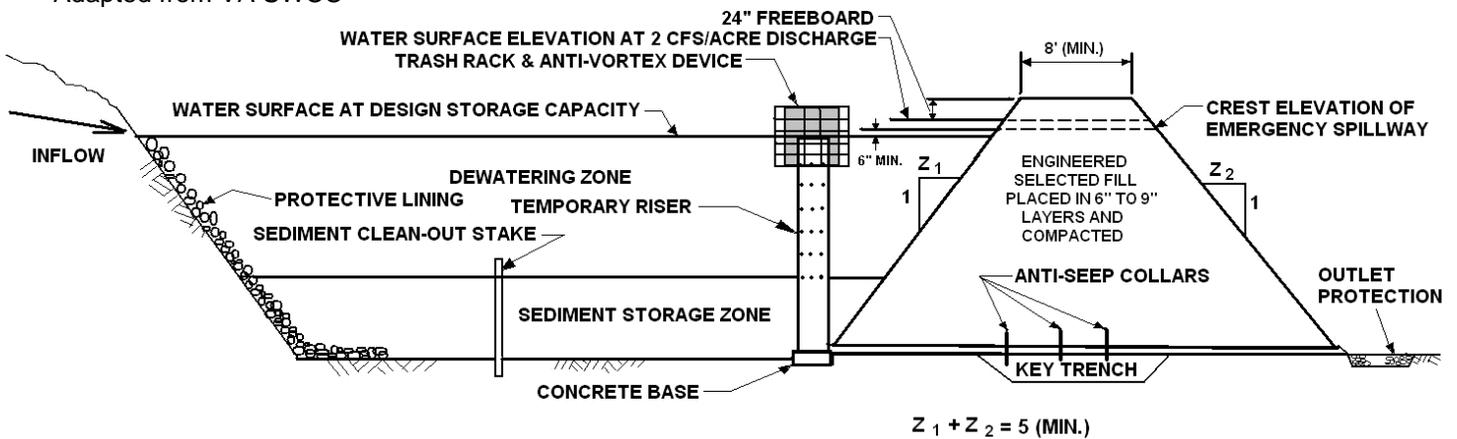


$$\text{AVERAGE WIDTH (W)} = \frac{\text{AREA AT ELEVATION 3}}{L}$$

WHERE: L = MAXIMUM LENGTH OF BASIN AT ELEVATION 3

**PLAN VIEW**

Adapted from VA SWCC



**TYPICAL SECTION**

PA DEP

**NOTE: This figure is for illustration purposes only and should not be used as a construction detail.**

## STORAGE VOLUME CRITERIA

A sediment storage zone of 1,000 cubic feet per disturbed acre within the watershed of the basin is required. The elevation at which the required capacity is provided should be marked on a clean-out stake located near the center of the basin. Accumulated sediment should be removed from the basin whenever it reaches that elevation on the clean-out stake.

A dewatering zone volume of 5,000 cubic feet for each acre tributary to the basin — disturbed and undisturbed — is also to be provided. Reductions in the dewatering zone are allowed for the factors listed below. However the minimum required dewatering zone is at least 3,600 cubic feet per acre. The dewatering zone volume is in addition to the sediment storage volume. No reduction in dewatering zone volume will be permitted in basins located in special protection watersheds; such basins should also use principal spillways that dewater from the top 6 inches of the dewatering zone or have permanent pools greater than or equal to 18 inches deep.

- (1) A reduction of 700 cubic feet per acre may be claimed for basins with principal spillways that dewater from the top 6 inches of the dewatering zone.
- (2) A reduction of 700 cubic feet per acre for basins with permanent pools greater than or equal to 18 inches average depth. The sediment storage zone is in addition to the permanent pool.
- (3) A reduction of 350 cubic feet per acre for basins with flow length to average basin width ratios of 4L:1W or greater at the top of the dewatering zone.
- (4) A reduction of 350 cubic feet per acre for basins with dewatering times ranging from 4 to 7 days.

**NOTE: The applicant should demonstrate in the calculations and/or on the plan drawings that the requirements have been met for each volume reduction claimed.**

## DESIGN PROCEDURE

### **Determine Required Storage and Discharge Capacities**

Standard E&S Worksheet #12 is to be used for this purpose.

1. The drainage area to be used is the maximum area that will be tributary to the basin during construction at the project site. Since watersheds often change during grading operations, roadway construction, installation of sewer lines, and construction of buildings and parking lots, the maximum drainage area is not necessarily the pre- or post-construction drainage area. This area may overlap an adjacent drainage area to another basin. The watershed areas used to size basins should be delineated on the E&S plan maps. If this is not possible or undesirable due to clutter, a legible copy of the work map(s) used to size the basin(s) should be provided.
2. The disturbed area includes all areas that will be disturbed during the life of the basin whether they are all disturbed at the same time or not.
3. Using the criteria above, calculate the required sediment storage volume, and dewatering zone volume.
4. Calculate the required discharge capacity as 2 cfs/acre — disturbed and undisturbed — or the routed 25-year, 24-hour storm.



**Develop a Stage Storage Curve.**

Use Standard E&S Worksheet #14 for this purpose.

1. Determine the surface area of the basin at each contour line within the proposed basin (with a 2' maximum interval between contours). Show Elevation 2 and Elevation 3 — from E&S Worksheet #13 — on E&S Worksheet # 14 of the submittal.
2. Calculate the volume between the contours.
3. Record the data on the table.
4. Plot the data on the graph.

**Determine the Sediment Storage Elevation.**

1. Use the required sediment storage volume ( $S_d$ ) from Standard E&S Worksheet #12 to find the elevation on the stage storage curve that corresponds to that volume.
2. The top of the skimmer landing device or the bottom row of perforations on the principal spillway riser should be located at this elevation.

**Determine the Elevation at which the Total Storage Volume is provided.**

1. Using the total storage volume ( $S_t$ ) from Standard E&S Worksheet #12, find the elevation on the stage storage curve that corresponds to that volume.
2. This elevation is the minimum elevation for the maximum skimmer reach or the crest of the principal spillway riser — top of the dewatering zone, elevation 3 on Standard E&S Worksheet #13.

**NOTE: Dimensions and elevations shown on plan drawings, with the exception of riser or skimmer orifices, should be rounded up to the nearest 6" for constructability.**

Except for activities in special protection watersheds, the minimum dewatering time for sediment basins is 2 days (48 hours). The maximum dewatering time should not exceed 7 days or 168 hours. Sediment basins in special protection watersheds should be designed to dewater in no less than 4 days or 96 hours when at full capacity ( $S_t$ ). The lower limit of dewatering is the top of the sediment storage zone — Elevation 2 on Standard E&S Worksheet #13 — or the top of the permanent pool if a permanent pool is provided. The upper limit is the top of the dewatering zone.

Sediment basins may be dewatered using a temporary perforated riser, or preferably a skimmer to discharge water from the top of the dewatering zone.

Skimmer Dewatering - This device has a **HIGH** sediment removal efficiency and is an **ABACT** for **HQ** and **EV** watersheds.



Chester County Conservation District

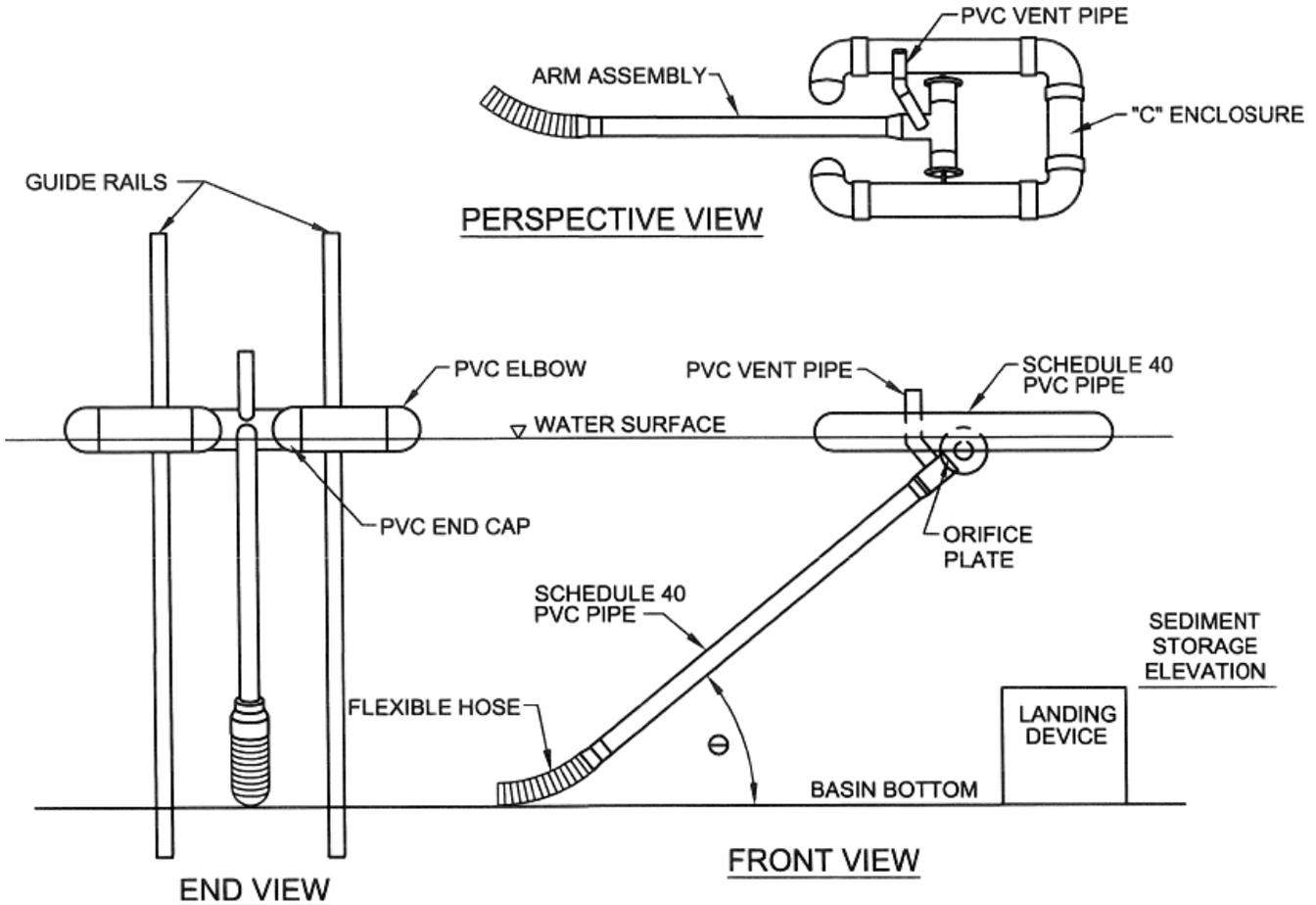
Standard Construction Details # 7-1 through # 7-4 and Figure 7.2 (adapted from Penn State Agricultural and Biological Engineering Fact Sheet F-253) may be used to specify the skimmer dewatering device. Standard Construction Detail # 7-1 is recommended for temporary basins and Standard Construction Detail # 7-2 is recommended for permanent basins. Wherever this device is used, calculations should be provided in the narrative to indicate the arm length required to allow the skimmer to reach the top of the dewatering zone. All critical dimensions and elevations should be shown on the E&S Plan detail sheets, including: diameter and length of arm (minimum arm length = maximum design storage depth  $\times \sqrt{2}$  for  $\Theta = 45$  degrees)\*, length of flexible hose, orifice diameter, and the elevation of the top of the landing device. Details showing how the skimmer will be securely attached to the permanent riser or outlet barrel should also be provided.

Prefabricated skimmers may be used provided the manufacturer's recommendations are followed and evidence is provided that the device will effectively dewater the dewatering zone within the required time period. Manufacturer's recommendations as well as all pertinent design calculations should be included in the narrative.

In some instances, it may be advantageous to attach the skimmer to a temporary riser (e.g. a temporary basin having no permanent riser) to provide some or all of the required discharge capacity. In those cases, the configuration would be similar to that shown in Standard Construction Detail # 7-2 with a temporary riser substituted for the permanent one shown in the drawing.

\* Maximum design storage depth = Water Surface Elevation (WSE) - Temporary Stub Invert Elevation (TSIE).  $\theta$  should be **45° or less when the water surface is at the maximum pool elevation - the elevation of the 2 cfs/acre discharge or routed 25-year, 24-hour storm.**

**STANDARD CONSTRUCTION DETAIL # 7-1  
Skimmer**



Adapted from Penn State Agricultural and Biological fact Sheet F-253

NOTE: This table is intentionally blank and should be filled in by the plan preparer.

Basin No.	Water Surface Elevation (ft)	Arm Length (ft)	Arm Dia. (in)	Orifice Size* (in)	Top of Landing Device Elevation (ft)	Flexible Hose Length (in)	Flexible Hose Attachment Elevation (ft)

\* Must be equal to or less than arm diameter

**A rope shall be attached to the skimmer arm to facilitate access to the skimmer once installed.**

**Skimmer shall be inspected weekly and after each runoff event.**

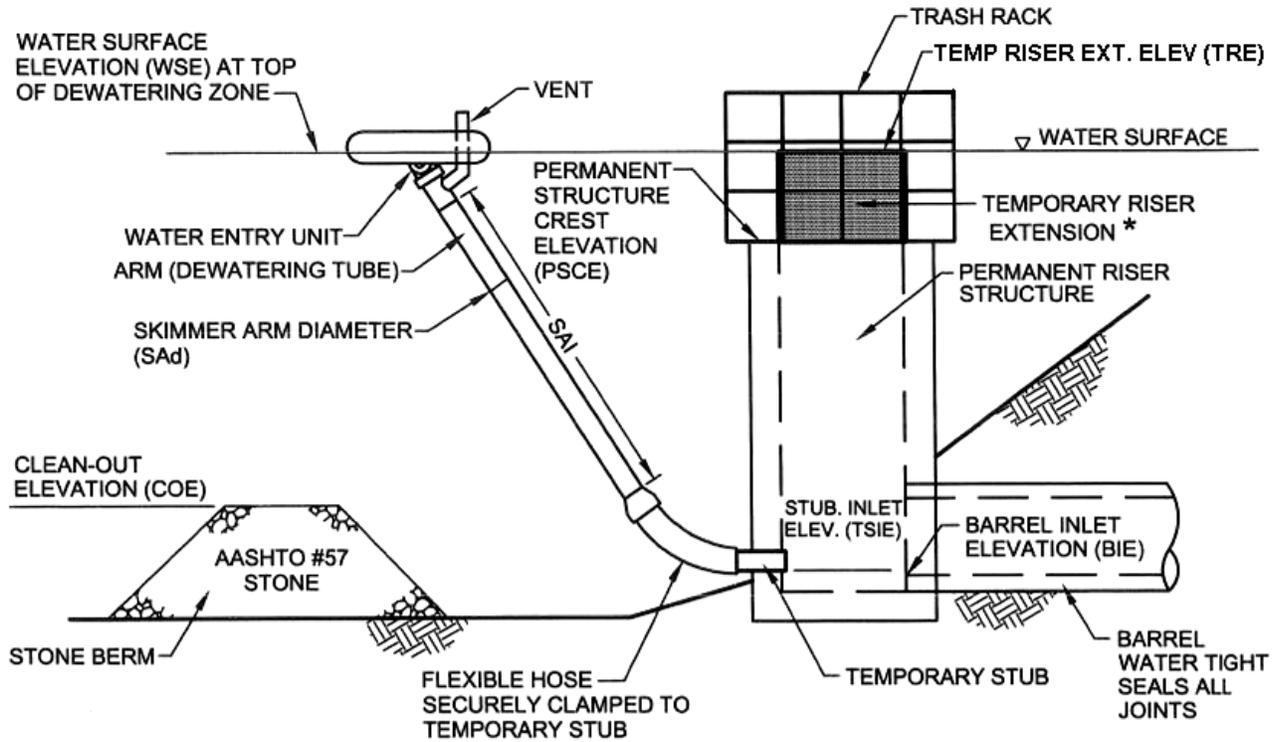
**Any malfunctioning skimmer shall be repaired or replaced within 24 hours of inspection.**

**Ice or sediment buildup around the principal spillway shall be removed so as to allow the skimmer to respond to fluctuating water elevations.**

**Sediment shall be removed from the basin when it reaches the level marked on the sediment clean-out stake or the top of the landing device.**

**A semi-circular landing zone may be substituted for the guide rails (Standard Construction Detail # 7-3).**

**STANDARD CONSTRUCTION DETAIL # 7-2  
Skimmer Attached to a Permanent Riser**



PA DEP

NOTE: This table is intentionally blank and should be filled in by the plan preparer.

BASIN NO.	WATER SURFACE ELEV. WSE (FT)	SKIMMER							
		ORIFICE		ARM			FLEXIBLE HOSE		
		DIA (IN)	HEAD (FT)	DIA SAd (IN)	LENGTH SAI (FT)	MAT'L	DIA (IN)	LENGTH (IN)	MAT'L

TEMPORARY STUB			PERMANENT RISER			RISER EXTENSION			BARREL
INSIDE DIA (IN)	INVERT ELEV. TSIE (FT)	MAT'L	CREST ELEV. PSCE (FT)	HORIZ OPENING		CREST ELEV. TRE (FT)	HORIZ OPENING		INLET ELEV. BIE (FT)
				LENGTH EI (IN)	WIDTH Ew (IN)		LENGTH (IN)	WIDTH (IN)	

All orifices on permanent riser below temporary riser extension shall have water-tight temporary seals provided. Temporary stub invert elevation shall be set at or below sediment clean-out elevation.

A rope shall be attached to the skimmer arm to facilitate access to the skimmer once installed.

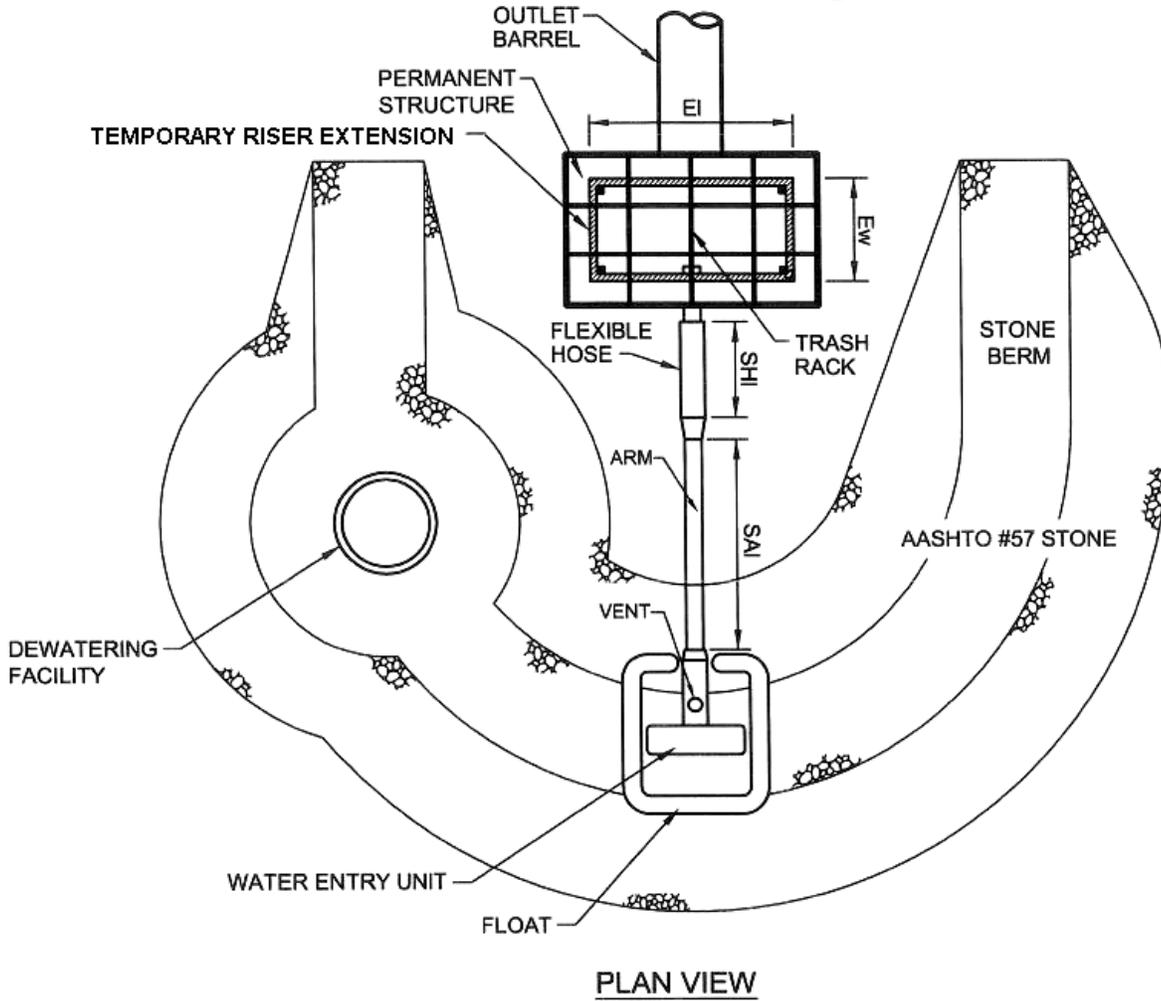
Skimmer shall be inspected weekly and after each runoff event.

Any malfunctioning skimmer shall be repaired or replaced within 24 hours of inspection.

Ice or sediment buildup around the principal spillway shall be removed so as to allow the skimmer to respond to fluctuating water elevations.

**Sediment shall be removed from the basin when it reaches the level marked on the sediment clean-out stake or the top of the stone berm. See Standard Construction Detail # 7-3 for configuration of stone berm.**

**STANDARD CONSTRUCTION DETAIL # 7-3  
Skimmer with Stone Landing Berm**

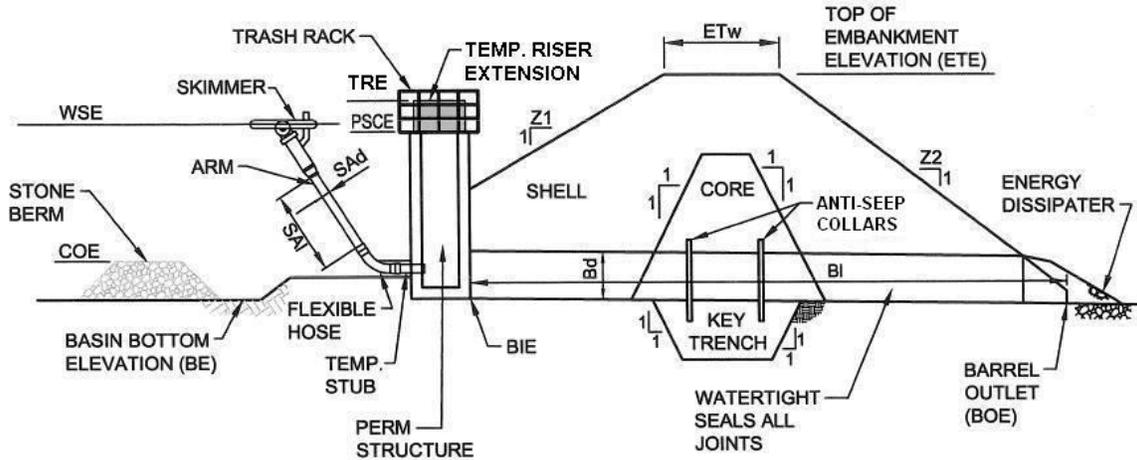


PA DEP

**No guide rails shall be required for this installation.**

**This detail shall be used in conjunction with Standard Construction Details # 7-2 and # 7-4.**

## STANDARD CONSTRUCTION DETAIL # 7-4 Sediment Basin Embankment and Spillway Details - Skimmer



PA DEP

NOTE: This table is intentionally blank and should be filled in by the plan preparer.

BASIN NO.	Z1 (FT)	Z2 (FT)	TEMP RISER EXT. ELEV. TRE (FT)	EMBANKMENT				CLEAN OUT ELEV COE (FT)	BOTTOM ELEV BE (FT)
				TOP ELEV ETE (FT)	TOP WIDTH ETw (FT)	KEY TRENCH DEPTH (FT)	KEY TRENCH WIDTH (FT)		

SKIMMER			OUTLET BARREL				
DIA SAd (IN)	LENGTH SAI (FT)	MAT'L	DIA Bd (IN)	INLET ELEV BIE (FT)	MAT'L	LENGTH BI (FT)	OUTLET ELEV BOE (FT)

Sediment basins, including all appurtenant works, shall be constructed to the detail and dimensions shown on the E&S plan drawings.

Area under embankment shall be cleared, grubbed, and stripped of topsoil to a depth of two feet prior to any placement and compaction of earthen fill. In order to facilitate maintenance and restoration, the pool area shall be cleared of all brush, trees, and objectionable material. Fill material for the embankments shall be free of roots, or other woody vegetation, organic material, large stones, and other objectionable materials. The embankment shall be compacted in layered lifts of not more than 6" to 9". The maximum rock size shall be no greater than 2/3 the lift thickness.

Upon completion, the embankment shall be seeded, mulched, blanketed or otherwise stabilized according to the specifications of the E&S plan drawings. Trees shall not be planted on the embankment.

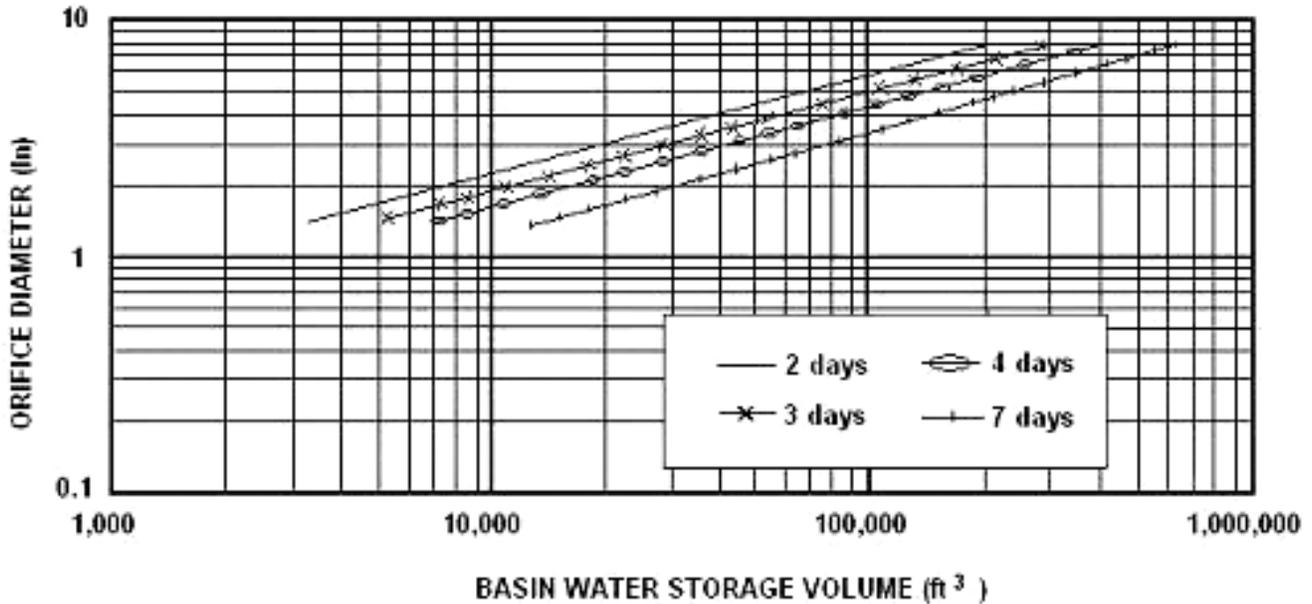
Inspect all sediment basins on at least a weekly basis and after each runoff event. Provide access for sediment removal and other required maintenance activities. A clean out stake shall be placed near the center of each basin. Accumulated sediment shall be removed when it has reached the clean out elevation on the stake and the basin restored to its original dimensions. Dispose of materials removed from the basin in the manner described in the E&S plan.

Basin embankments, spillways, and outlets shall be inspected for erosion, piping and settlement. Necessary repairs shall be immediately. Displaced riprap within the outlet energy dissipater shall be replaced immediately.

**Accumulated sediment shall be removed and disturbed areas shall be stabilized inside the basin before conversion to a stormwater management facility. The device shown in Standard Construction Detail #7-18 may be used to dewater saturated sediment prior to its removal. Rock filters shall be added as necessary.**



**FIGURE 7.2**  
**Skimmer Orifice Design Chart**



Adapted from Penn State Agricultural and Biological Fact Sheet F-253

Figure 7.2 is for use in designing the orifice plate for the skimmer shown in Standard Construction Detail # 7-1 or # 7-2. It assumes a 2" to 5" head (depending upon the size of the skimmer). The required head for use of Figure 7.2 varies as follows: For a skimmer with a dewatering tube  $\leq 2 \frac{1}{2}$ " diameter, use a 2" head. For a 3" diameter tube, use a 2.5" head; 4" tube, use 3.3" head; 5" tube use 4" head, and 6" diameter tube use 5" head.

Find the vertical line representing the basin's dewatering zone volume. At the intersection of the vertical line with the desired dewatering time, read horizontally to the left to find the required skimmer orifice diameter.

**Skimmer Orifice Design Example:**

For a basin with a dewatering volume of 40,000 cubic feet and a desired dewatering time of two days, the required skimmer orifice diameter is 4 inches. Indicate this dimension on the plan drawings (as a note on the typical or in the summary table). There must be a sufficient number of holes in the underside of the water entry unit of the skimmer to allow water to enter freely into the skimmer orifice. The outlet pipe or barrel must be capable of discharging at the rate permitted by the skimmer and in all cases must be equal to or larger in dimension than the orifice diameter. This dimension should also be indicated on the plan drawings. Anti-seep collars are recommended for the barrel.

When erodible soils or soils having a high content of fine silts will be disturbed in the drainage area of a sediment basin, longer settling times will result in a higher percentage of suspended solids removal. Therefore, settling times of 4 to 7 days are recommended in such situations.

Perforated Riser Dewatering - This device has **MODERATE** sediment removal efficiency and is an **ABACT** for HQ, but not EV, watersheds unless used in conjunction with sediment forebay with flocculation or turbidity barrier.



PA DEP

For sediment basins with perforated risers, designers may use the following rule of thumb. Provide 1 square inch of opening per acre of drainage area with all perforations one inch in diameter and equally spaced vertically along the riser. NOTE: A 1" diameter perforation provides 0.785 sq. in. of opening. Therefore, the number of perforations needed may be determined by dividing the total number of acres tributary to the basin by 0.785. The lowest row of perforations is at the sediment storage zone elevation (i.e. sediment clean-out elevation). No further computation of dewatering time is required if the rule of thumb is used correctly. The rule of thumb may not be used in special protection (HQ or EV) watersheds where a longer dewatering time may be required than that provided by the rule of thumb.

Wherever total dewatering of the basin is necessary, and perforations are located below the top of the sediment storage zone, the rule of thumb may not be used. In these instances, the discharge through the perforations in the sediment storage zone as well as perforations in the dewatering zone must be considered when computing dewatering time. In most cases, only one or two perforations will be needed below the top of sediment storage zone to facilitate total dewatering (Standard Construction Detail # 7-11).

The rule of thumb is not a precise procedure. If an accurate dewatering time is required, Standard E&S Worksheets #15 and # 16 should be used.

#### **Determine the principal spillway discharge capacity.**

The combined capacities of the principal and emergency spillways should be at least 2 cfs/acre for the entire watershed of the basin. An acceptable alternative is to route the anticipated peak flow from the 25-year, 24-hour storm event without encroaching on freeboard.

The principal spillway should be analyzed for three possible limiting flow types: weir flow, orifice flow (top of pipe only, not through perforations), and pipe flow. The principal spillway discharge capacity is the smallest of these three flow rates. Weir flow/orifice flow may be determined from Figure 7.3 or by the following equations:

1. Orifice Flow:  $Q = CA (2gh)^{0.5}$

Where: Q = discharge in cubic feet per second (cfs)  
C = orifice coefficient, use C = 0.6 for corrugated metal pipe risers  
A = cross-sectional area of the riser pipe in square feet  
g = acceleration due to gravity, 32.2 ft/sec<sup>2</sup>  
H = head above riser crest in feet

2. Weir Flow:  $Q = CLH^{1.5}$

Where: Q = discharge in cubic feet per second (cfs)  
C = weir coefficient, use 3.1 for corrugated metal pipe risers.  
L = circumference of the riser in feet  
H = head above riser crest in feet

3. Pipe Flow:  $Q = a [(2gh) / (1 + K_m + K_p L)]^{0.5}$

Where: Q = discharge in cubic feet per second (cfs)  
a = cross-sectional area of the barrel in square feet  
g = acceleration due to gravity, 32.2 ft/sec<sup>2</sup>  
h = head above the centerline of the outlet end of the barrel  
K<sub>m</sub> = coefficient of minor losses, can be assumed to be 1.0 for most principal spillway systems  
K<sub>p</sub> = pipe friction coefficient =  $(5087 n^2) / di^{4/3}$  (See Table 7.1 for K<sub>p</sub> values for common sizes of pipe.)

Where: n = Manning's coefficient of roughness (0.025 for corrugated metal pipe, 0.015 for reinforced concrete pipe)  
Di = inside diameter of the barrel in inches  
L = barrel length in feet

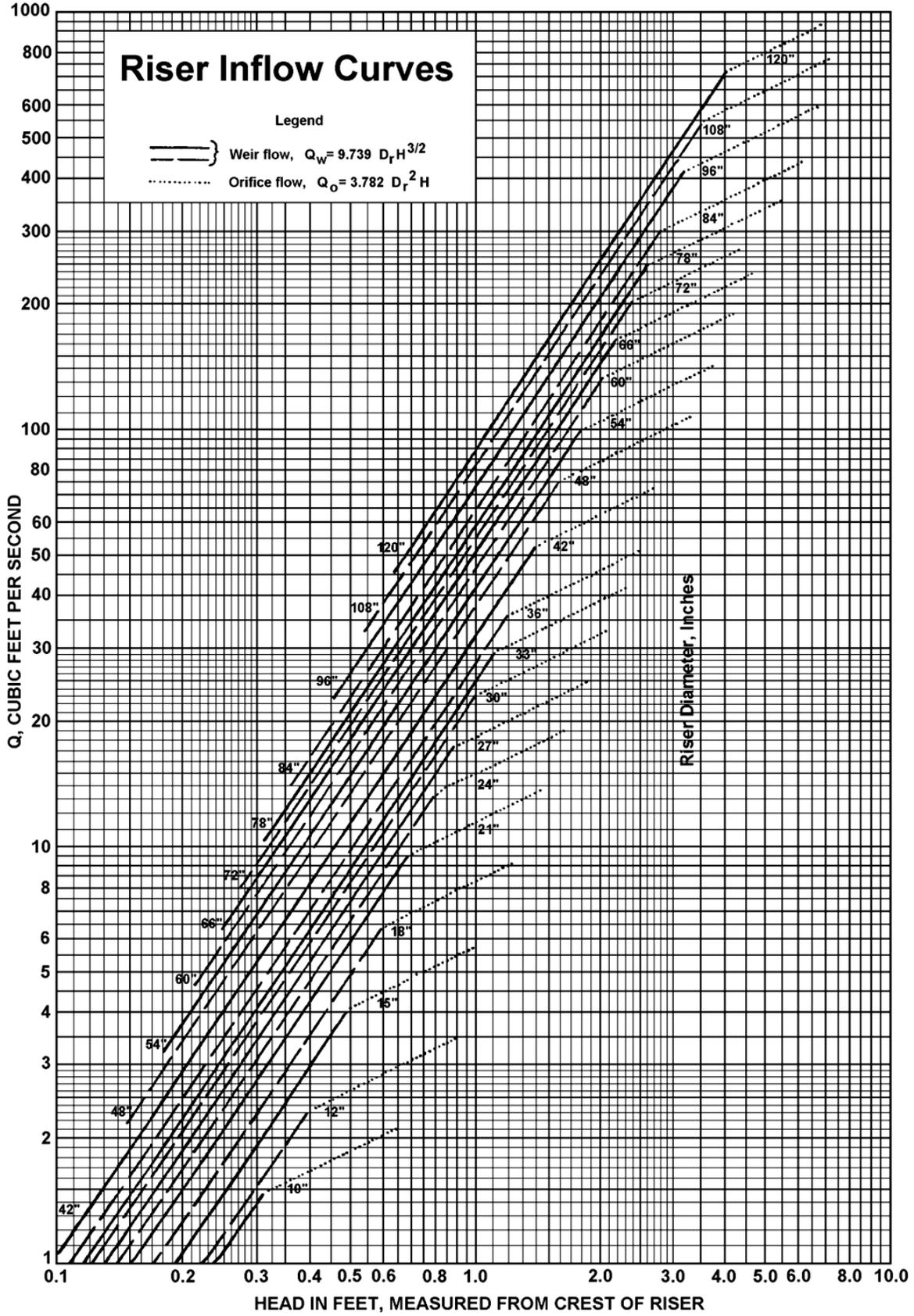
Pipe Flow may also be derived from Table 7.2 or 7.3.

**TABLE 7.1**  
**K<sub>p</sub> Values for Common Sizes of Pipe**

Pipe Diameter (inches)	Flow Area (sq. ft)	Manning's Coefficient	
		Concrete Pipe n = 0.015	Corrugated Metal Pipe n = 0.025
6	0.196	0.1050	0.2916
8	0.349	0.0715	0.1987
10	0.545	0.0531	0.1476
12	0.785	0.0417	0.1157
14	1.069	0.0339	0.0942
15	1.23	0.0309	0.0859
16	1.40	0.0284	0.0789
18	1.77	0.0243	0.0674
21	2.41	0.0198	0.0549
24	3.14	0.0165	0.0459
27	3.98	0.0141	0.0393
30	4.91	0.0123	0.0341
36	7.07	0.0096	0.0267
42	9.62	0.0078	0.0218
48	12.57	0.0066	0.0182
54	15.90	0.0056	0.0156
60	19.64	0.0049	0.0135

PA DEP

**FIGURE 7.3**  
**Riser Inflow Curves**



Adapted from USDA, NRCS

<b>TABLE 7.2 - PIPE FLOW CAPACITY - n = 0.015</b>									
<b>For 70' long Corrugated Plastic Pipe, where Km = 1, (full flow assumed)</b>									
<b>H (FT)</b>	<b>Barrel Diameter (IN)</b>								
	<b>12</b>	<b>15</b>	<b>18</b>	<b>21</b>	<b>24</b>	<b>30</b>	<b>36</b>	<b>42</b>	<b>48</b>
<b>1</b>	2.8	4.8	7.4	10.5	14.2	23.3	34.7	48.4	64.3
<b>2</b>	4.0	6.8	10.4	14.8	20.1	32.9	49.1	68.4	90.9
<b>3</b>	4.9	8.4	12.8	18.2	24.6	40.3	60.1	83.8	111.4
<b>4</b>	5.7	9.7	14.7	21.0	28.4	46.6	69.4	96.7	128.6
<b>5</b>	6.4	10.8	16.5	23.5	31.7	52.1	77.6	108.1	143.8
<b>6</b>	7.0	11.8	18.1	25.7	34.8	57.1	85.0	118.5	157.5
<b>7</b>	7.5	12.8	19.5	27.8	37.5	61.6	91.8	128.0	170.1
<b>8</b>	8.0	13.6	20.9	29.7	40.1	65.9	98.1	136.8	181.9
<b>9</b>	8.5	14.5	22.1	31.5	42.6	69.9	104.1	145.1	192.9
<b>10</b>	9.0	15.3	23.3	33.2	44.9	73.7	109.7	152.9	203.4
<b>11</b>	9.4	16.0	24.5	34.8	47.1	77.3	115.1	160.4	213.3
<b>12</b>	9.8	16.7	25.5	36.4	49.1	80.7	120.2	167.5	222.8
<b>13</b>	10.2	17.4	26.6	37.8	51.2	84.0	125.1	174.4	231.9
<b>14</b>	10.6	18.1	27.6	39.3	53.1	87.2	129.8	181.0	240.6
<b>15</b>	11.0	18.7	28.6	40.6	55.0	90.2	134.4	187.3	249.1

<b>Barrel Length (FT)</b>	<b>Correction Factors for Various Barrel Lengths and Diameters</b>								
	<b>12</b>	<b>15</b>	<b>18</b>	<b>21</b>	<b>24</b>	<b>30</b>	<b>36</b>	<b>42</b>	<b>48</b>
<b>20</b>	1.32	1.26	1.22	1.19	1.16	1.13	1.10	1.09	1.07
<b>30</b>	1.23	1.19	1.16	1.14	1.12	1.10	1.08	1.07	1.06
<b>40</b>	1.16	1.13	1.12	1.10	1.09	1.07	1.06	1.05	1.04
<b>50</b>	1.10	1.08	1.07	1.06	1.06	1.05	1.04	1.03	1.03
<b>60</b>	1.05	1.04	1.03	1.03	1.03	1.02	1.02	1.02	1.01
<b>70</b>	1.00	1.00	1.00	1.00	1.00	1.00	1.00	1.00	1.00
<b>80</b>	0.96	0.96	0.97	0.97	0.97	0.98	0.98	0.98	0.99
<b>90</b>	0.92	0.93	0.94	0.95	0.95	0.96	0.97	0.97	0.97
<b>100</b>	0.89	0.90	0.91	0.92	0.93	0.94	0.95	0.96	0.96
<b>110</b>	0.86	0.88	0.89	0.90	0.91	0.92	0.93	0.94	0.95
<b>120</b>	0.84	0.85	0.87	0.88	0.89	0.91	0.92	0.93	0.94
<b>130</b>	0.81	0.83	0.85	0.86	0.87	0.89	0.91	0.92	0.93
<b>140</b>	0.79	0.81	0.83	0.84	0.86	0.88	0.89	0.91	0.92
<b>150</b>	0.77	0.79	0.81	0.83	0.84	0.86	0.88	0.90	0.91
<b>160</b>	0.75	0.77	0.79	0.81	0.82	0.85	0.87	0.88	0.90

USDA NRCS

<b>TABLE 7.3 - PIPE FLOW CAPACITY n = 0.025</b>									
<b>For 70' long Corrugated Metal Pipe, where Km = 1, (full flow assumed)</b>									
<b>H (FT)</b>	<b>Barrel Diameter (IN)</b>								
	<b>12</b>	<b>15</b>	<b>18</b>	<b>21</b>	<b>24</b>	<b>30</b>	<b>36</b>	<b>42</b>	<b>48</b>
<b>1</b>	2.0	3.5	5.5	8.0	11.0	18.8	28.8	41.1	55.7
<b>2</b>	2.8	4.9	7.7	11.3	15.6	26.6	40.8	58.2	78.8
<b>3</b>	3.4	6.0	9.5	13.8	19.1	32.6	49.9	71.2	96.5
<b>4</b>	4.0	7.0	10.9	16.0	22.1	37.6	57.7	82.3	111
<b>5</b>	4.4	7.8	12.2	17.9	24.7	42.1	64.5	92.0	125
<b>6</b>	4.9	8.5	13.4	19.6	27.0	46.1	70.6	101	136
<b>7</b>	5.2	9.2	14.5	21.1	29.2	49.8	76.3	109	147
<b>8</b>	5.6	9.8	15.5	22.6	31.2	53.2	81.5	116	158
<b>9</b>	6.0	10.4	16.4	24.0	33.1	56.4	86.5	123	167
<b>10</b>	6.3	11.0	17.3	25.3	34.9	59.5	91.2	130	176
<b>11</b>	6.6	11.5	18.2	26.5	36.6	62.4	95.6	136	185
<b>12</b>	6.9	12.1	19.0	27.7	38.2	65.2	99.9	142	193
<b>13</b>	7.2	12.6	19.7	28.8	39.8	67.8	104	148	201
<b>14</b>	7.4	13.0	20.5	29.9	41.3	70.4	108	154	208
<b>15</b>	7.7	13.5	21.2	30.9	42.8	72.8	112	159	216

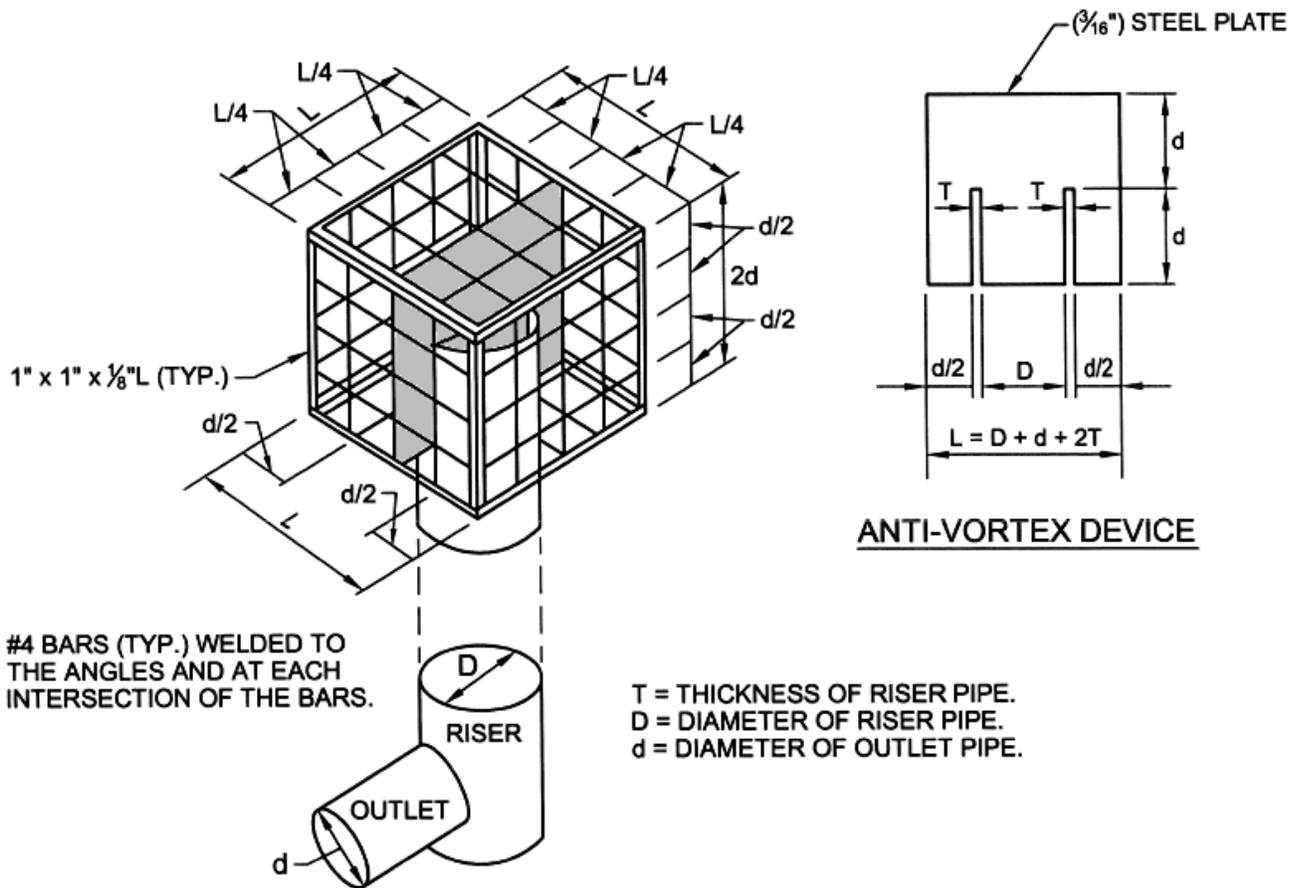
<b>Barrel Length (FT)</b>	<b>Correction Factors for Various Barrel Lengths and Diameters</b>								
	<b>12</b>	<b>15</b>	<b>18</b>	<b>21</b>	<b>24</b>	<b>30</b>	<b>36</b>	<b>42</b>	<b>48</b>
<b>20</b>	1.53	1.47	1.42	1.37	1.34	1.28	1.24	1.20	1.18
<b>30</b>	1.36	1.32	1.29	1.27	1.24	1.21	1.18	1.15	1.13
<b>40</b>	1.23	1.21	1.20	1.18	1.17	1.14	1.12	1.11	1.10
<b>50</b>	1.14	1.13	1.12	1.11	1.10	1.09	1.08	1.07	1.06
<b>60</b>	1.06	1.06	1.05	1.05	1.05	1.04	1.04	1.03	1.03
<b>70</b>	1.00	1.00	1.00	1.00	1.00	1.00	1.00	1.00	1.00
<b>80</b>	0.95	0.95	.095	.096	.096	.096	0.97	0.97	0.97
<b>90</b>	0.90	0.91	0.91	0.92	0.92	0.92	0.93	0.94	0.94
<b>100</b>	0.86	0.87	0.88	0.89	0.89	0.90	0.91	0.92	0.93
<b>120</b>	0.80	0.81	0.82	0.83	0.83	0.85	0.86	0.87	0.89
<b>140</b>	0.75	0.76	0.77	0.78	0.79	0.81	0.82	0.84	0.85
<b>160</b>	0.70	0.71	0.73	0.74	0.75	0.77	0.79	0.80	0.82

USDA NRCS

**THE PRINCIPAL SPILLWAY RISER(S) SHOULD HAVE A TRASH RACK AND AN ANTI-VORTEX DEVICE.** Standard Construction Detail # 7-5 is an acceptable version of a trash rack and anti-vortex device. Other designs that adequately prevent floating debris from plugging the riser and minimize the effects of swirling of water entering the top of the riser may also be approved.

The principal spillway riser should be securely anchored and attached to the outlet barrel with a water-tight seal (Standard Construction Details # 7-7 and # 7-9). Table 7.4 may be used to determine the minimum amount of concrete to anchor risers of typical diameter.

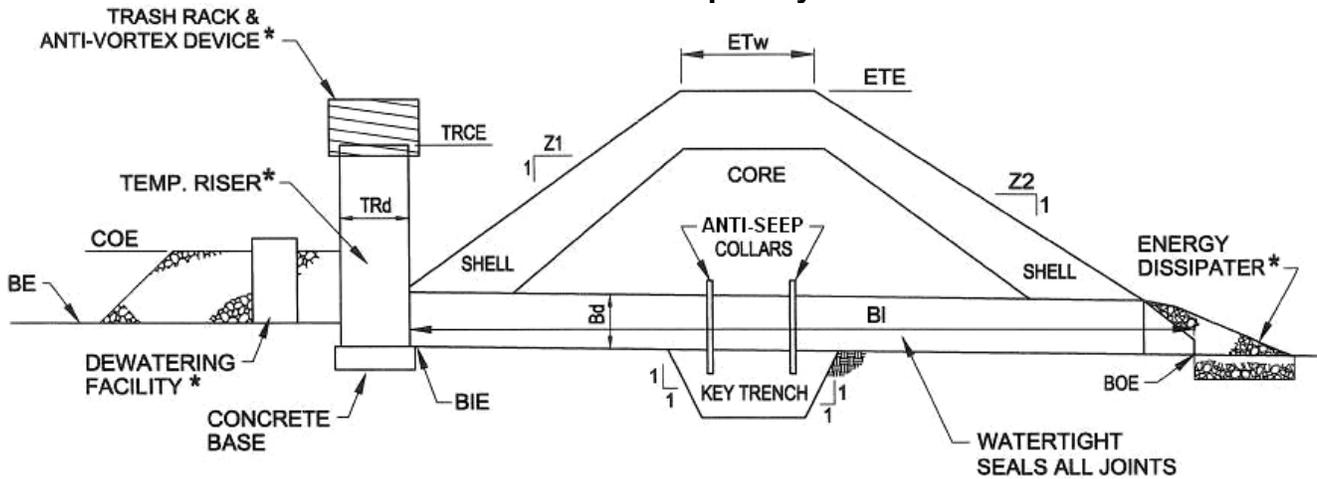
**STANDARD CONSTRUCTION DETAIL # 7-5  
Trash Rack and Anti-vortex Device**



Adapted from PennDOT Pub.RC-72M



**STANDARD CONSTRUCTION DETAIL # 7-6  
Sediment Basin Embankment and Spillway Details - Perforated Riser**



PA DEP

NOTE: This table is intentionally blank and should be filled in by the plan preparer.

BASIN NO.	Z1 (FT)	Z2 (FT)	TEMPORARY RISER			BARREL					
			DIA TRd (IN)	CREST ELEV TRCE (FT)	MAT'L	DIA Bd (IN)	INLET ELEV BIE (FT)	MAT'L	LENGTH BI (FT)	OUTLET ELEV BOE (FT)	

EMBANKMENT				CLEANOUT ELEV COE (FT)	BOTTOM ELEV BE (FT)
TOP ELEV ETE (FT)	TOP WIDTH Etw (FT)	KEY TRENCH DEPTH (FT)	KEY TRENCH WIDTH (FT)		

\*Also refer to sediment basin temporary riser, emergency spillway, energy dissipater, trash rack and anti-vortex device, and sediment storage dewatering facility details.

Sediment basins, including all appurtenant works, shall be constructed to the detail and dimensions shown on the E&S plan drawings.

Area under embankment shall be cleared, grubbed, and stripped of topsoil to a depth of two feet prior to any placement and compaction of earthen fill. Fill material for the embankments shall be free of roots, or other woody vegetation, organic material, large stones, and other objectionable materials. The embankment shall be compacted in layered lifts of not more than 6" to 9". The maximum rock size shall be no greater than 2/3 the lift thickness. Upon completion, the embankment shall be seeded and mulched or otherwise stabilized according to the specifications of the E&S plan drawings. Trees shall not be planted on the embankment.

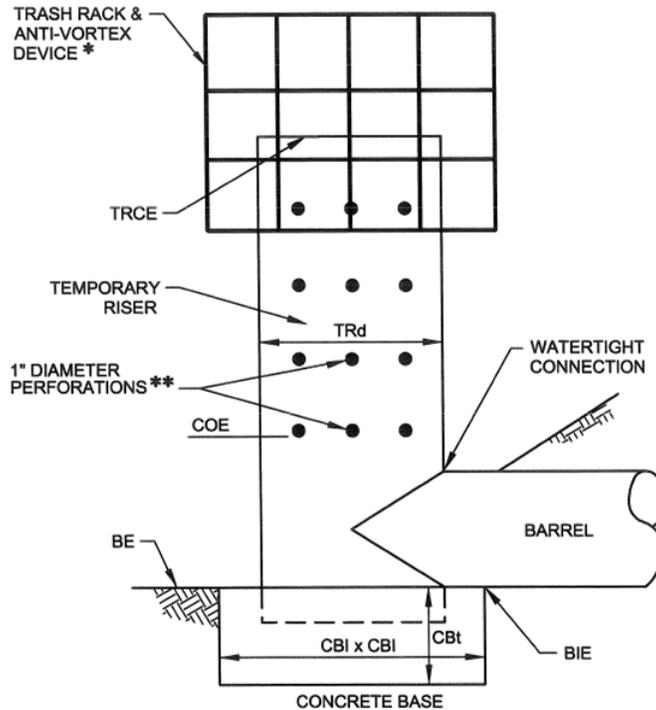
Access shall be provided for sediment removal and other required maintenance activities.

A clean out stake shall be placed near the center of each basin. Accumulated sediment shall be removed when it has reached the clean out elevation on the stake and restore the basin to its original dimensions. Dispose of materials removed from the basin in the manner described in the E&S plan.

Inspect all sediment basins on at least a weekly basis and after each runoff event. Check basin embankments, spillways, and outlets for erosion, piping and settlement. Necessary repairs shall be made immediately. Displaced riprap within the outlet energy dissipater shall be

**replaced immediately. Accumulated sediment shall be removed and disturbed areas shall be stabilized inside the basin before conversion to a stormwater management facility. The device shown in Standard Construction Detail #7-18 may be used to dewater saturated sediment prior to its removal. Rock filters shall be added as necessary.**

**STANDARD CONSTRUCTION DETAIL # 7-7  
Sediment Basin Temporary Riser\***



PA DEP

NOTE: This table is intentionally blank and should be filled in by the plan preparer.

BASIN NO.	TEMPORARY RISER			PERFORATIONS			
	DIA TRd (IN)	CREST ELEV TRCE (FT)	MAT'L	LOWEST ROW OF HOLES ELEV (FT)	NO. ROWS**	NO. HOLES PER ROW	VERTICAL SPACING OF ROWS (FT)

CONCRETE BASE		BARREL
LENGTH and WIDTH CBI (IN)	THICKNESS CBt (IN)	INLET ELEV BIE (FT)

\* See Standard Construction Detail #7-5, Trash Rack and Anti-vortex Device

\*\*Lowest row of holes at sediment clean-out elevation.

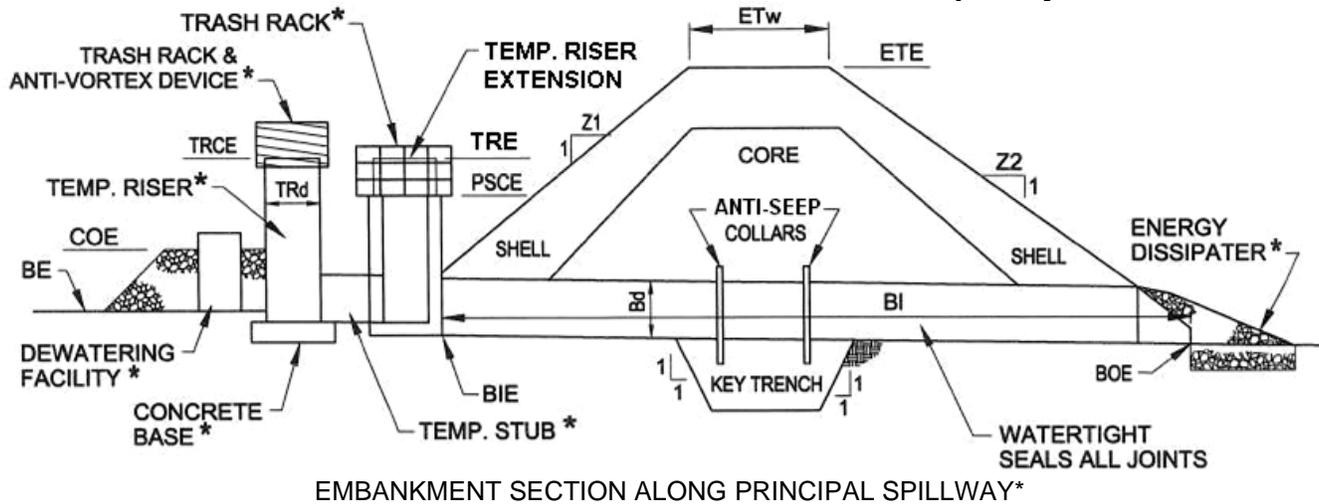
A minimum 2 #8 rebar shall be placed at right angles and projecting through sides of riser to anchor it to concrete base. Rebar shall project a minimum of ¼ riser diameter beyond outside of riser.

Concrete base shall be poured in such a manner so as to insure that concrete fills bottom of riser to invert of the outlet pipe to prevent riser from breaking away from the base. Minimum base width equals 2 times riser diameter.

Embedded section of aluminum or aluminized pipe shall be painted with zinc chromate or equivalent.

**Clogged or damaged spillways shall be repaired immediately. Trash and other debris shall be removed from the basin and riser.**

## STANDARD CONSTRUCTION DETAIL # 7-8 Sediment Basin/Detention Pond Embankment and Spillway Details



PA DEP

NOTE: This table is intentionally blank and should be filled in by the plan preparer.

BASIN NO.	Z1 (FT)	Z2 (FT)	TEMP RISER EXT ELEV TRE (FT)	TEMPORARY RISER			BARREL					
				DIA TRd (IN)	CREST ELEV TRCE (FT)	MAT'L	DIA Bd (IN)	INLET ELEV BIE (FT)	MAT'L	LENGTH BI (FT)	OUTLET ELEV BOE (FT)	

EMBANKMENT		CLEAN OUT ELEV COE (FT)	BOTTOM ELEV BE (FT)
TOP ELEV ETE (FT)	TOP WIDTH Etw (FT)		

\* See sediment basin temporary riser & permanent structure, emergency spillway, trash rack & anti-vortex device, energy dissipater, and sediment storage dewatering facility details.

Sediment basins, including all appurtenant works, shall be constructed to the detail and dimensions shown on the E&S plan drawings.

Area under embankment shall be cleared, grubbed, and stripped of topsoil to a depth of two feet prior to any placement and compaction of earthen fill. Fill material for the embankments shall be free of roots, or other woody vegetation, organic material, large stones, and other objectionable materials. The embankment shall be compacted in layered lifts of not more than 6" to 9". The maximum rock size shall be no greater than 2/3 the lift thickness. Upon completion, the embankment shall be seeded and mulched or otherwise stabilized according to the specifications of the E&S plan drawings. Trees shall not be planted on the embankment.

All sediment basins shall be inspected on at least a weekly basis and after each runoff event.

Access for sediment removal and other required maintenance activities shall be provided.

A clean out stake shall be placed near the center of each basin. Accumulated sediment shall be removed when it has reached the clean out elevation on the stake and the basin restored to its original dimensions. Dispose of materials removed from the basin in the manner described in the E&S plan.

Basin embankments, spillways, and outlets shall be checked for erosion, piping and settlement. Necessary repairs shall be made immediately. Displaced riprap within the outlet energy dissipater shall be replaced immediately. Accumulated sediment shall be removed and

**disturbed areas inside the basin stabilized before conversion to a stormwater management facility. The device shown in Standard Construction Detail #7-18 may be used to dewater saturated sediment prior to its removal. Rock filters shall be added as necessary.**

**TABLE 7.4**  
**Concrete Base Requirements for Various Sizes of Temporary Riser Pipes**

<b>Riser Pipe Diameter (in)</b>	<b>Buoyant Force (lb/V.F. of Riser Height)</b>	<b>Volume of Concrete per Vertical Foot of Riser Height (cf/VF) Needed to Prevent Flotation</b>
12	49.0	0.69
18	110.3	1.54
21	150.1	2.10
24	196.0	2.75
30	306.3	4.29
36	441.1	6.18
48	784.1	10.98
54	992.4	13.90
60	1225.2	17.16

Georgia DNR

EXAMPLE: Find the volume of concrete required to stabilize a 24 inch diameter riser 10 feet high.

$$\text{VOL} = (2.75 \text{ cu. ft./V.F.}) (10 \text{ feet}) = 27.5 \text{ cu. ft.} \approx 1 \text{ cu. yd.}$$

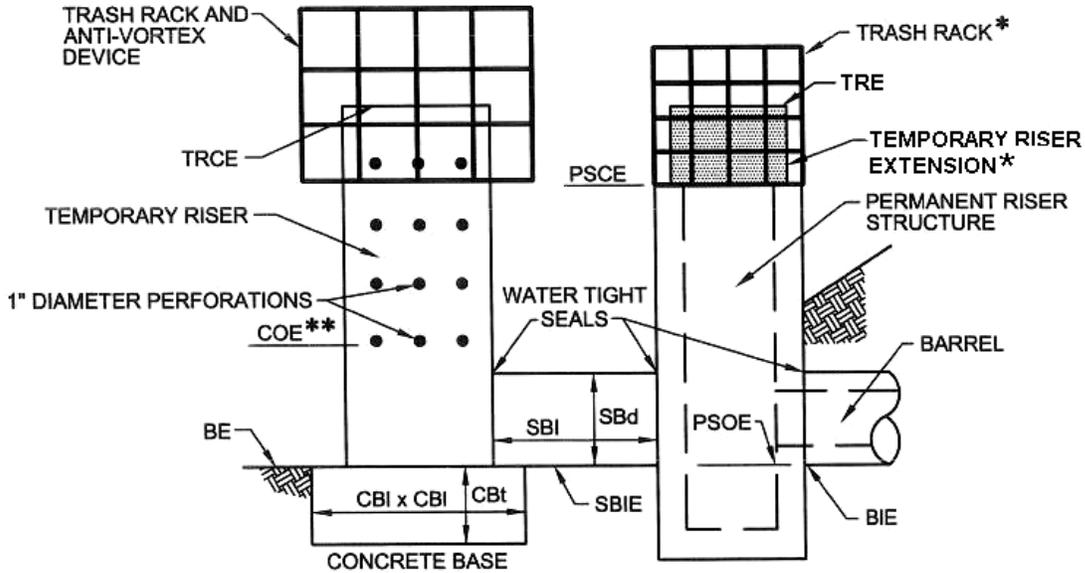
Note: Minimum 2 #8 rebar placed at right angles and projecting through sides of riser to anchor it to concrete base. Rebar should project a minimum of ¼ riser diameter beyond outside of riser.

Concrete bases should be poured in such a manner as to insure that concrete fills the bottom of riser to the invert of the outlet pipe to prevent riser from breaking away from the base. Minimum base width should equal 2 times riser diameter.

The embedded section of aluminum or aluminized pipe should be painted with zinc chromate or equivalent.

In permanent basins, a temporary riser is typically attached to the permanent riser by means of a stub. To promote a tight seal of the temporary stub connection with the permanent riser structure, it is recommended that a flange plate — welded to the end of the stub barrel — be bolted and caulked to the permanent outlet structure. Simply grouting the pipe is often not effective and usually requires constant maintenance.

**STANDARD CONSTRUCTION DETAIL # 7-9  
Sediment Basin/Detention Pond Riser Structures**



PA DEP

NOTE: This table is intentionally blank and should be filled in by the plan preparer.

BASIN NO.	TEMPORARY RISER			PERFORATIONS				CONCRETE BASE	
	DIA TRd (IN)	CREST ELEV TRE (FT)	MAT'L	LOWEST ROW OF HOLES ELEV. (FT)	NO. ROWS**	NO. HOLES PER ROW	VERTICAL SPACING OF ROWS (FT)	LENGTH and WIDTH CBI (IN)	THICK. CBt (IN)

BASIN NO.	TEMPORARY STUB				PERMANENT STRUCTURE			BARREL INLET ELEV BIE (FT)
	DIA SBd (IN)	INVERT ELEV SBIE (FT)	MAT'L	LENGTH SBI (FT)	CREST ELEV PSCE (FT)	CREST ELEV TRE (FT)	OUTLET ELEV PSOE (FT)	

\* See Standard Construction Detail #7-5, Trash Rack and Anti-vortex Device and Standard Construction Detail #7-7, Sediment Basin Temporary Riser. Top of temporary riser extension (TRE) shall be equal to or above temporary riser crest elevation (TRCE) and 6 inches (minimum) below crest of emergency spillway. Remove flat grate from permanent riser for as long as basin functions as a sediment removal BMP.

\*\* Lowest row of holes at sediment clean-out elevation

A minimum 2 #8 rebar shall be placed at right angles and projecting through sides of riser to anchor it to concrete base. Rebar shall project a minimum of ¼ riser diameter beyond outside of riser.

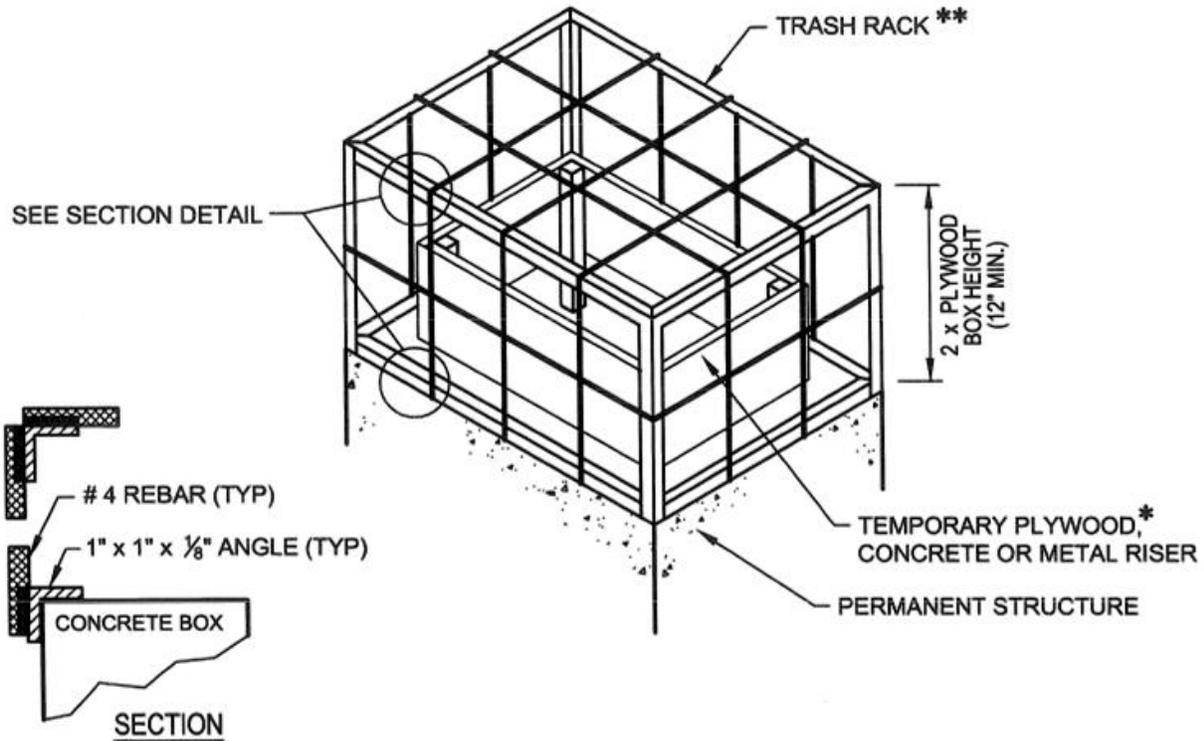
Concrete base shall be poured in such a manner to insure that concrete fills bottom of riser to invert of the outlet pipe to prevent riser from breaking away from the base. Minimum base width equals 2 times riser diameter.



**Embedded section of aluminum or aluminized pipe shall be painted with zinc chromate or equivalent.**

**Clogged or damaged spillways shall be repaired immediately. Trash and other debris from the basin and riser shall be removed.**

**STANDARD CONSTRUCTION DETAIL # 7-10**  
**Temporary Riser Extension and Trash Rack for Permanent Structure**



PA DEP

- \*  $\frac{3}{4}$ " pressure treated plywood box with 2" x 2" pressure treated corner supports, set into 1½" grate offsets, caulk all seams to form watertight seals.
- \*\* Trash rack composed of 1" x 1" x 1/8" L (typ.) and #4 Bars (typ.) welded to the angles and at each intersection of the bars; #4 Bars spaced at half the diameter of the barrel max.

**Box shall be bolted, strapped, or otherwise secured to the permanent riser.**

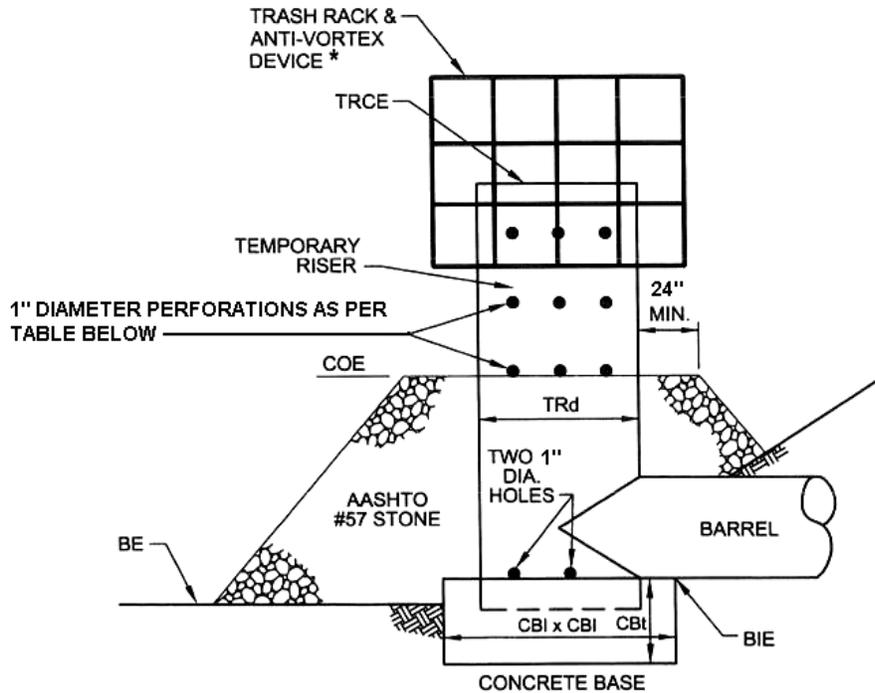
**Top of temporary riser extension shall be at least as high as sediment basin temporary riser and shall be 6" (minimum) below crest of emergency spillway.**

**All joints shall be water tight.**

**Clogged or damaged spillways shall be repaired immediately. Trash and other debris shall be removed from the basin and riser.**

Wherever total basin dewatering is required, two 1" diameter holes should be located at the bottom of the riser and a 2' thick layer of AASHTO #57 stone placed around the riser up to the top of the sediment storage zone. Filter cloth wrapped around the riser is not an acceptable alternative due to its tendency to become clogged. In special protection watersheds, a 6" layer of compost should be placed and securely anchored on top of the stone on all sides to provide increased sediment removal efficiency. Standard Construction Detail # 7-11 should be revised to show the compost layer for all such installations. An acceptable alternative is to replace the stone with a suitable compost filter sock with a 24" minimum diameter securely staked. Include all perforations in dewatering time calculations.

**STANDARD CONSTRUCTION DETAIL # 7-11  
Dry Sediment Basin Temporary Riser\***



PA DEP

NOTE: This table is intentionally blank and should be filled in by the plan preparer.

BASIN NO.	TEMPORARY RISER			PERFORATIONS			CONCRETE BASE		BARREL
	DIA TRd (IN)	CREST ELEV TRCE (FT)	MAT'L	NO. HOLES PER ROW	VERTICAL SPACING (FT)	BOTTOM ROW ELEV COE (FT)	LENGTH and WIDTH CBI (IN)	THICK. CBt (IN)	INLET ELEV BIE (FT)

\* See Standard Construction Detail #7-5, Trash Rack and Anti-vortex Device.

**Clogged or damaged spillways shall be repaired immediately. Trash and other debris shall be removed from the basin and riser.**

**A minimum 2 #8 rebar shall be placed at right angles and projecting through sides of riser to anchor it to concrete base. Rebar shall project a minimum of ¼ riser diameter beyond outside of riser.**

**Concrete base shall be poured in such a manner to insure that concrete fills bottom of riser to invert of the outlet pipe to prevent riser from breaking away from the base. Minimum base width equals 2 times riser diameter.**

**Embedded section of aluminum or aluminized pipe shall be painted with zinc chromate or equivalent.**

### Freeboard

A minimum of 24 inches of freeboard is required above the elevation at which the 2 cfs per acre discharge capacity is provided — or the maximum water surface elevation while routing the anticipated peak flow from the 25-year, 24-hour storm event. If the emergency spillway is being used to discharge part of the design discharge, the 24 inch freeboard should be provided above the design flow elevation through the emergency spillway. **An acceptable alternative is to provide a spillway combination with the capacity to pass the peak flow from a 100-year, 24-hour storm event with 12” of freeboard.**

Emergency Spillway - Every sediment basin should be provided with an emergency spillway.



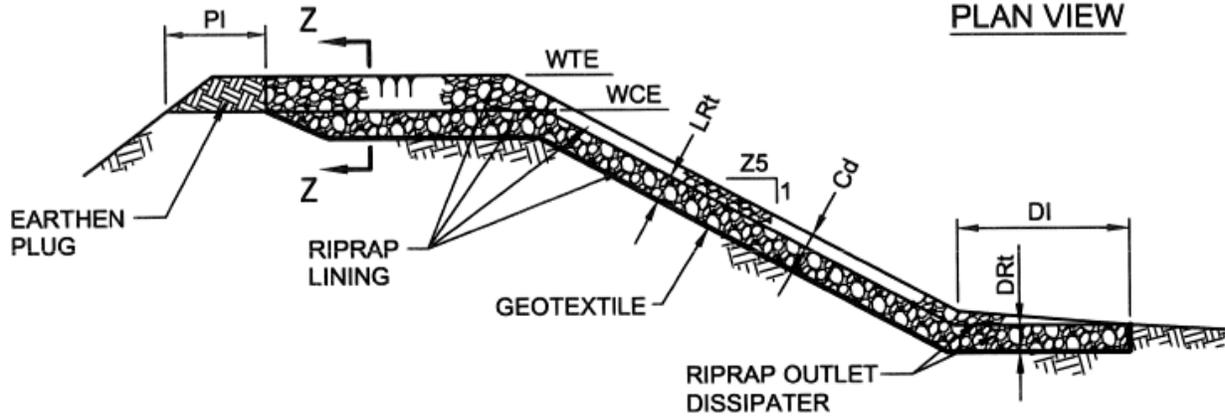
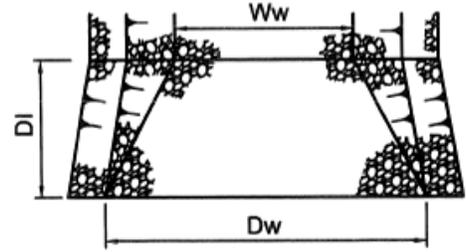
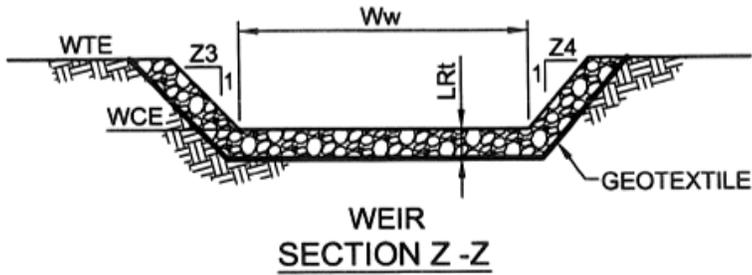
PA DEP

The elevation of the emergency spillway crest should be at least 6” above that of the principal spillway.

Emergency spillways should be located on undisturbed ground, wherever possible. Otherwise, the emergency spillway should have a TRM, riprap or other hard armor protection which extends at least 15 feet beyond the toe of the embankment to the receiving waterway (DI), channel or other non-erosive outlet. Minimum width at the end of the armor protection ( $D_w$ ) should be 0.4 times the length of the apron unless discharging directly into a channel leading away from the apron. Where a TRM is used to line the spillway down the face of the embankment, the channel at the toe of the embankment should be lined with riprap a sufficient length in both directions to prevent scour.

Wherever riprap is used as a protective liner in an emergency spillway, a compacted and stabilized earthen plug should be left in place on the inner side of the spillway to prevent water from discharging through the emergency spillway until the design water elevation is reached, as shown in Standard Construction Detail #7-12). **Note: Provide supporting calculations for the outlet channels of all emergency spillways.**

**STANDARD CONSTRUCTION DETAIL # 7-12  
Sediment Basin Emergency Spillway with Riprap Lining**



**EMBANKMENT SECTION ALONG EMERGENCY SPILLWAY**

PA DEP

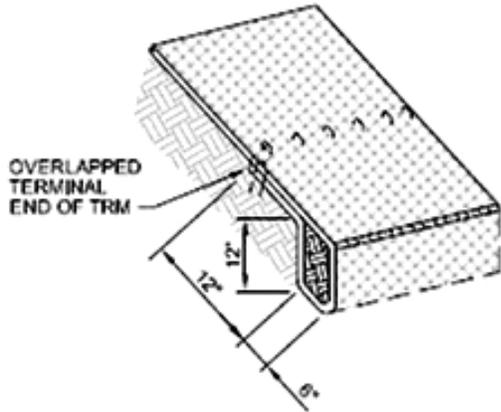
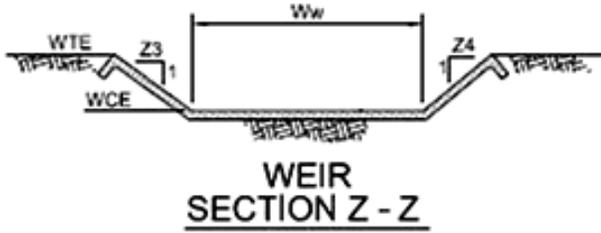
NOTE: This table is intentionally blank and should be filled in by the plan preparer.

BASIN NO.	WEIR					LINING		CHANNEL		DISSIPATER			
	Z3 (FT)	Z4 (FT)	TOP ELEV WTE (FT)	CREST ELEV WCE (FT)	WIDTH Ww (FT)	RIPRAP SIZE (R-___)	RIPRAP THICK. LRt (IN)	Z5 (FT)	DEPTH Cd (FT)	LENGTH DI (FT)	WIDTH Dw (FT)	RIPRAP SIZE (R-___)	RIPRAP THICK. DRt (IN)

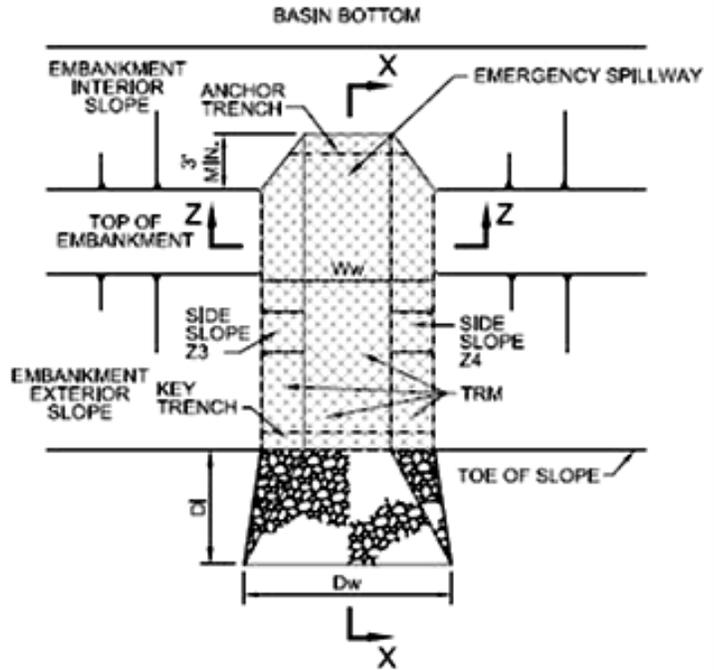
**Dimension PI shall be 5' minimum.**

**Displaced riprap within the spillway and/or outlet channel shall be replaced immediately.**

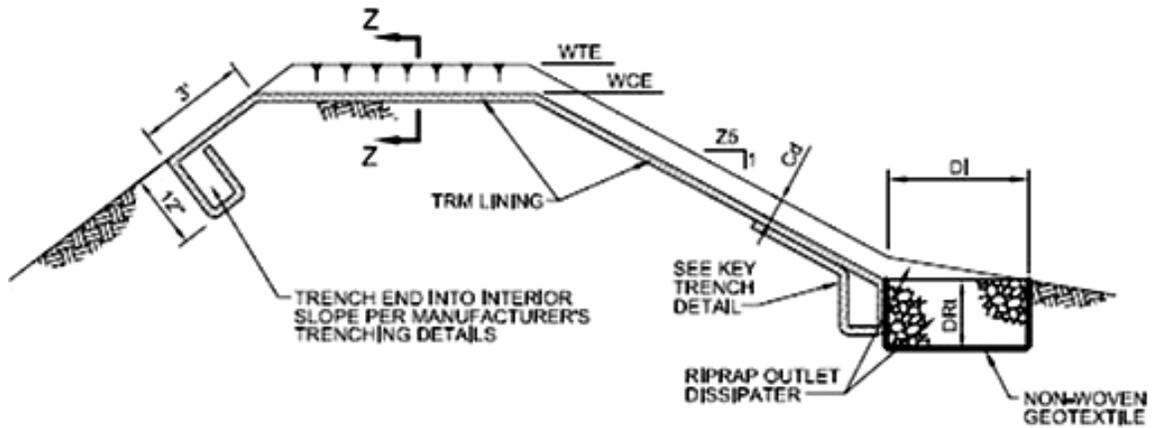
**STANDARD CONSTRUCTION DETAIL # 7-13**  
**Sediment Basin Emergency Spillway with TRM Lining**



**KEY TRENCH AT TOE OF SLOPE OF SPILLWAY**



**PLAN VIEW  
 RIPRAP OUTLET DISSIPATOR**



**EMBANKMENT SECTION ALONG EMERGENCY SPILLWAY  
 SECTION X-X**

East Coast Erosion Blankets, LLC

NOTE: This table is intentionally blank and should be filled in by the plan preparer.

BASIN NO.	WEIR					LINING		CHANNEL		DISSIPATER			
	Z3 (FT)	Z4 (FT)	TOP ELEV WTE (FT)	CREST ELEV WCE (FT)	WIDTH W w (FT)	TRM Type	STAPLE PATTERN	Z5 (FT)	DEPTH C d (FT)	LENGTH Dl (FT)	WIDTH D w (FT)	RIPRAP SIZE (R- )	RIPRAP THICK. DRt (IN)

Heavy equipment shall not cross over spillway without precautions taken to protect TRM lining.

Displaced liner within the spillway and/or outlet channel shall be replaced immediately.

**Riprap at toe of embankment shall be extended a sufficient length in both directions to prevent scour.**

**The use of baffles that require support posts are restricted from use in basins requiring impervious liners.**

**Check the capacity of the emergency spillway.**

1. Tables 7.5, through 7.8 are recommended for determining emergency spillway capacity for grass-lined spillways. Spillways lined with rock will typically have less capacity for the same-sized spillway.

<b>Head (ft)</b>	<b>Bottom Width (ft)</b>											
	<b>8</b>	<b>10</b>	<b>12</b>	<b>14</b>	<b>16</b>	<b>18</b>	<b>20</b>	<b>22</b>	<b>24</b>	<b>26</b>	<b>28</b>	<b>30</b>
<b>0.5</b>	6	7	8	10	11	13	14	15	17	18	20	21
<b>0.6</b>	8	10	12	14	16	18	19	21	23	25	27	29
<b>0.7</b>	10	12	13	17	20	23	24	28	29	31	34	36
<b>0.8</b>	13	15	18	22	25	28	31	35	36	39	42	45
<b>0.9</b>	17	19	23	27	31	35	38	42	45	48	52	55
<b>1.0</b>	18	22	28	32	37	41	46	50	52	56	61	65
<b>1.1</b>	22	26	32	36	42	47	52	57	61	66	72	76
<b>1.2</b>	26	32	37	42	49	54	59	65	71	77	83	89
<b>1.3</b>	30	37	43	48	56	62	70	77	84	90	97	104
<b>1.4</b>	34	41	49	56	65	71	78	87	95	101	109	117
<b>1.5</b>	38	46	56	63	72	80	88	97	105	113	122	131
<b>1.6</b>	42	52	62	71	81	90	98	108	117	126	136	146
<b>1.7</b>	46	57	68	78	89	99	110	118	129	139	150	161
<b>1.8</b>	52	63	75	86	97	108	120	129	141	153	165	176
<b>1.9</b>	56	68	82	93	106	118	129	141	155	167	180	190
<b>2.0</b>	62	75	88	101	115	128	141	154	168	182	196	206
<b>2.1</b>	67	81	95	109	124	136	152	164	180	193	209	222
<b>2.2</b>	72	88	104	119	134	159	164	169	194	209	224	240
<b>2.3</b>	79	93	109	125	144	161	176	193	210	228	241	258
<b>2.4</b>	84	102	119	137	154	172	191	206	225	244	258	276

USDA NRCS Engineering Field Manual



**TABLE 7.6 - GRASS-LINED EMERGENCY SPILLWAY CAPACITY IN CFS  
(Side Slopes 2H:1V)**

Head (ft)	Bottom Width (ft)											
	8	10	12	14	16	18	20	22	24	26	28	30
0.5	6	7	8	10	11	13	14	15	17	18	20	21
0.6	8	10	12	14	16	18	20	22	24	26	28	30
0.7	11	13	16	18	20	23	25	28	30	33	35	38
0.8	13	16	19	22	26	29	32	35	38	42	45	46
0.9	17	20	24	28	32	35	39	43	47	51	53	57
1.0	20	24	29	33	38	42	47	51	56	61	63	68
1.1	23	28	34	39	44	49	54	60	65	70	74	79
1.2	28	33	40	45	51	58	64	69	76	80	86	92
1.3	32	38	46	53	58	65	73	80	86	91	99	106
1.4	37	44	51	59	66	74	82	90	96	103	111	119
1.5	41	50	58	66	75	85	92	101	108	116	125	133
1.6	46	56	65	75	84	94	104	112	122	132	142	149
1.7	52	62	72	83	94	105	115	126	135	145	156	167
1.8	58	69	81	93	104	116	127	138	150	160	171	182
1.9	64	76	88	102	114	127	140	152	164	175	188	201
2.0	71	83	97	111	125	138	153	164	178	193	204	218
2.1	77	91	107	122	135	149	162	177	192	207	220	234
2.2	84	100	116	131	146	163	177	194	210	224	238	253
2.3	90	108	124	140	158	175	193	208	226	243	258	275
2.4	99	116	136	152	170	189	206	224	241	260	275	294

USDA NRCS Engineering Field Manual

**TABLE 7.7 - GRASS-LINED EMERGENCY SPILLWAY CAPACITY IN CFS  
(Side Slopes 3H:1V)**

Head (ft)	Bottom Width (ft)											
	8	10	12	14	16	18	20	22	24	26	28	30
0.5	7	8	9	10	12	14	14	16	17	18	20	21
0.6	8	11	12	14	16	19	20	22	24	26	27	29
0.7	11	14	16	19	21	24	26	29	31	33	36	38
0.9	19	22	25	28	32	36	40	43	47	51	55	59
1.0	20	27	30	35	38	43	48	52	56	61	64	69
1.1	25	31	34	40	45	48	54	60	65	70	74	79
1.2	30	37	42	47	52	59	65	71	76	82	88	92
1.3	35	42	48	55	62	68	75	82	89	95	101	109
1.4	40	48	56	64	70	78	86	93	100	108	114	121
1.5	46	54	63	71	82	88	96	106	113	121	128	136
1.6	52	60	70	81	90	100	110	118	129	137	145	155
1.7	58	68	78	90	100	110	121	132	141	149	160	168
1.8	65	76	88	100	110	122	133	145	155	166	175	188
1.9	72	84	98	110	124	134	148	160	172	182	192	204
2.0	79	94	107	120	133	148	160	172	186	197	212	223
2.1	88	102	118	132	146	160	176	190	202	217	229	241
2.2	95	112	128	143	158	176	192	204	220	234	246	248
2.3	104	120	138	155	172	190	205	222	236	251	266	283
2.4	114	132	150	168	185	205	222	236	252	269	288	303

USDA NRCS Engineering Field Manual

Head (ft)	Bottom Width (ft)											
	8	10	12	14	16	18	20	22	24	26	28	30
0.5	7	8	9	10	12	14	16	18	19	21	23	25
0.6	9	11	12	14	17	19	21	23	25	28	30	32
0.7	11	14	16	19	21	24	26	29	31	34	37	39
0.8	14	17	20	23	26	30	32	35	38	42	45	48
0.9	19	22	25	27	32	36	40	45	49	51	55	59
1.0	22	27	31	35	39	45	48	53	57	61	65	70
1.1	27	32	36	41	47	52	57	60	66	71	76	81
1.2	34	38	45	50	57	61	67	72	78	84	90	96
1.3	38	45	50	57	64	73	79	89	91	98	106	110
1.4	43	51	58	66	75	81	89	95	102	109	117	125
1.5	50	58	67	74	84	93	100	110	118	125	134	143
1.6	57	71	75	83	92	100	113	121	131	141	149	159
1.7	63	75	85	95	106	115	124	133	144	155	164	175
1.8	73	88	95	106	116	129	137	149	160	173	183	194
1.9	80	92	104	114	128	141	152	165	176	188	200	213
2.0	89	102	113	127	140	153	167	180	191	205	217	230
2.1	96	112	125	140	154	168	186	195	207	223	238	253
2.2	105	122	137	153	168	183	198	216	229	244	261	274
2.3	119	134	149	166	183	200	215	232	247	266	282	297
2.4	129	146	162	179	198	217	232	252	266	284	302	319

USDA NRCS Engineering Field Manual

- An acceptable alternative is the equation for a broad-crested weir:

$$Q = CLH^{1.5}$$

Where this option is used, the maximum value of C should be 2.8. — relatively smooth liners. In many cases, a smaller C value should be used. The appropriate C value will vary depending upon the type of liner and anticipated flow depth — usually 2.4 to 2.6. Smaller values should be used for shallower flows over rough surfaces, larger values for deeper flows over smoother surfaces. The designer should indicate the standard reference used to determine the C value. L is the bottom width of the spillway at the crest, and H is the depth of flow above the spillway crest.

**Note: Manning's channel equation should not be used to size the control section of the emergency spillway.** However, it should be used to design the outlet channel below the spillway crest. Include all outlet channel dimensions and specifications on the plan drawings and provide supporting calculations in the narrative.

- The total of the emergency and principal spillway capacities for temporary basins should equal or exceed the required 2 cfs/acre discharge capacity, or be capable of discharging the routed 25-year, 24-hour storm event without encroaching upon the required freeboard. Permanent basins may require spillways with capacities exceeding 2 cfs/acre. An acceptable alternative to the 2 cfs/acre discharge capacity with 24" freeboard is a discharge capacity capable of handling the peak flow from a 100-year, 24-hour storm event — using maximum runoff conditions — while maintaining 12" of freeboard. The principal spillway should be used to handle as much of the required discharge capacity as possible. At a minimum, the principal spillway should be designed to convey the calculated peak flow from a 10-year, 24-hour storm event. Principal spillways of permanent basins may be required to have greater discharge capacities.

4. Once the depth of flow through the emergency spillway has been determined, the minimum elevation of the top of the embankment can be computed. This elevation should be at least 2 feet, or 24", above the water surface elevation at which the design discharge capacity is provided — or 12" above if the capacity is equal to the peak flow from a 100-year, 24-hour storm event.

The discharge from a sediment basin should be safely conveyed to a surface water or other approved alternative, and should be designed, operated, and maintained without causing accelerated erosion or sedimentation to the receiving water. Approved alternatives may include stable constructed channels, storm sewers, and similar facilities that can accept the discharge with no erosion occurring. Outlet channels extending between a sediment basin and a surface water should be designed according to the design discharge from the basin (i.e. 2 cfs/acre or peak flow from 100 year, 24 hour storm). If a portion of that flow discharges directly to a subsurface system, that portion may be subtracted from the design Q for the outlet channel.

Wherever the discharge from a permanent basin — or a temporary basin with a tributary drainage area that is at least 10% greater than the preconstruction condition — is to a flow path other than a surface water (e.g. a natural swale), calculations should be provided to show no net increase in the rate of discharge. If this is not possible, the flow path below the basin should be analyzed to determine whether accelerated erosion is likely to occur, based upon the calculated peak flow from a 10-year, 24-hour storm event. The analysis should be done at the point most vulnerable to erosion (e.g. steepest slope, erodible soil, least protective cover, etc.) between the point of discharge and the receiving surface water. For relatively uniform or extremely long flow paths, a point within 500 feet of the discharge point may be chosen. For discharges increasing the rate of flow onto a neighboring property prior to entering a surface water, an easement should be obtained prior to plan submittal.

Provide a suitable protective lining for each collector channel or other device that discharges to the basin; the lining should extend to the bottom of the basin and at least 10' along the basin bottom to dissipate excess energy.

Stabilize all interior slopes of the basin above the sediment storage zone, or permanent pool, elevation and the interior and exterior slopes of the embankment immediately upon completion of the basin.

#### Flow Length to Width Ratio

The minimum flow length to width ratio is 2L:1W — 4L:1W in special protection watersheds — unless a silt curtain, as shown in Figure 3.15 or 3.16, or sediment forebay, as shown in Figure 7.4, is provided.

The minimum required flow length can be determined as follows:

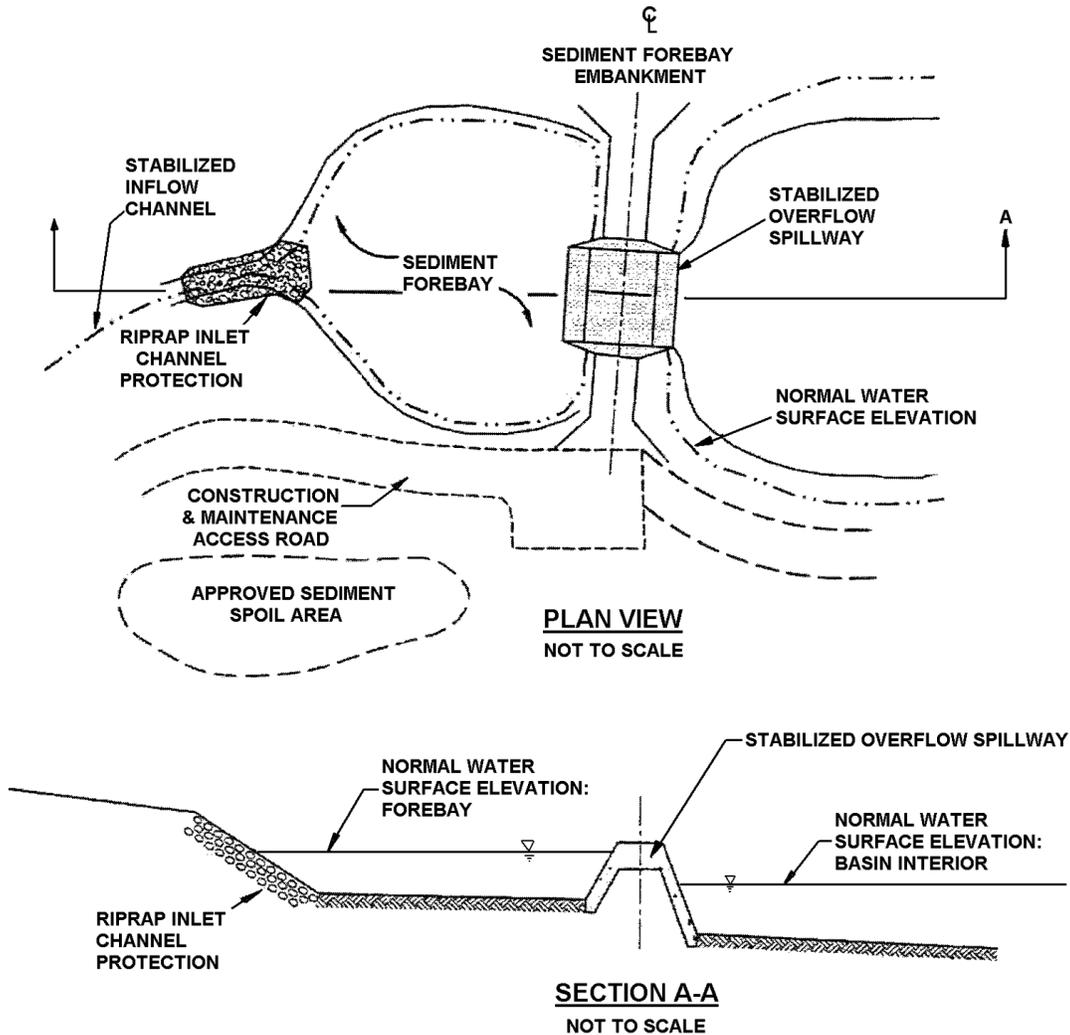
1. Determine the surface area of the basin at the top of the dewatering zone (elevation 3).
2. Divide the surface area by the maximum length of the basin at that elevation. The result is the average width of the basin at elevation 3.
3. Multiply the average width of the basin by 2 to determine the minimum flow length for a 2:1 ratio. If a 4:1 ratio is required, multiply the answer from step 2 by 4.

If the flow length from the outlet of a collector channel or inflow pipe to the principal spillway does not provide the required flow length to width ratio, either the collector alignment should be revised (e.g. moved so that the inlet to the basin is farther away from the principal spillway), or one or more baffles should be used to increase the flow length within the basin, as shown in Figure 7.5 and Standard Construction Detail # 7-13. Flow length is to be measured at the elevation of the top of the dewatering zone as shown on Elevation 3 on Standard E&S Worksheet #13. Note: super silt fence baffles should not be used in basins having storage depths — sediment storage plus dewatering zone — exceeding 5.0 feet. Basins or traps requiring impervious liners should not have baffles that use support posts. Wherever Jersey barriers or other concrete objects are used as baffles in such basins or traps, special care must be taken to prevent puncturing the liner during installation of the baffle. The Department

recommends that consideration be given to use of forebays or turbidity barriers, as discussed in Chapter 3, instead of baffles in such basins and traps.

Where runoff from disturbed areas enters a basin from different directions, it is better to combine flows from the various areas into a single inlet to the basin rather than have multiple inlets to the basin. If a designer chooses to reduce the dewatering zone of a basin by increasing the flow length to width ratio to 4L:1W, the flow length to width ratio for all inlets providing 10% or more of the inflow should be at least 4L:1W.

**FIGURE 7.4**  
**Typical Sediment Forebay**

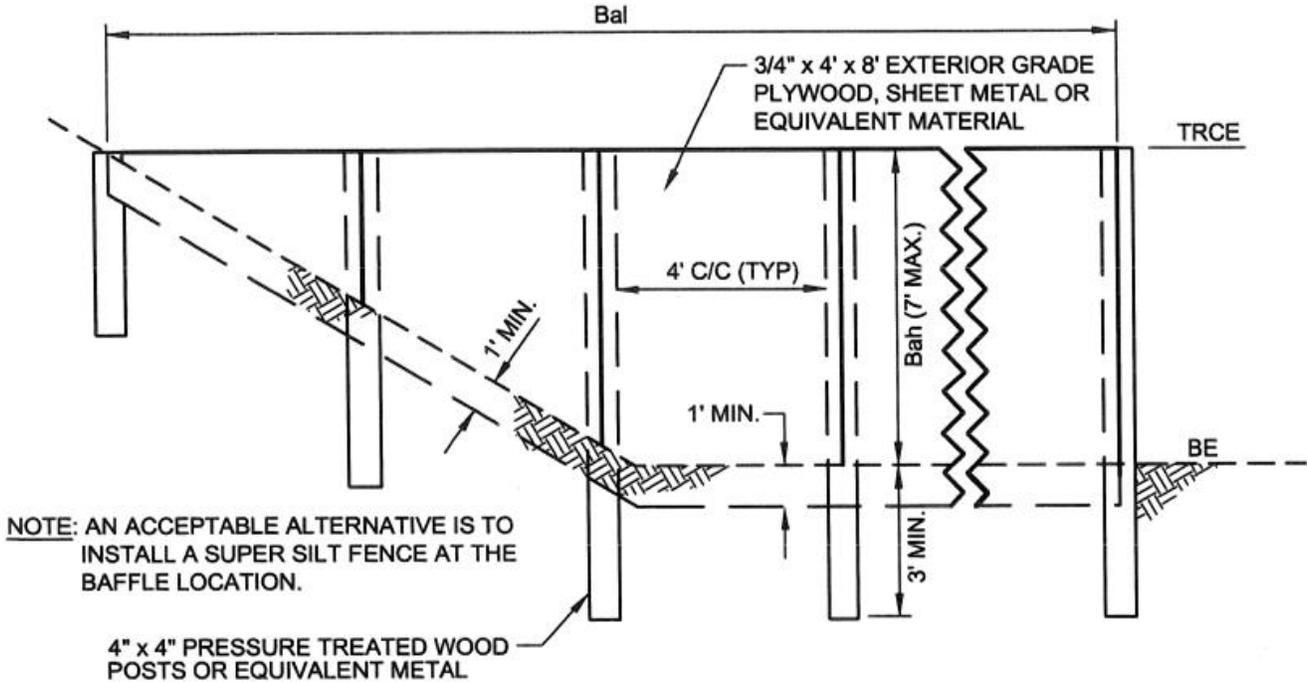


Source Unknown

Note: The overflow spillway of a forebay should not be a flow-through spillway. The berm should be constructed of non-permeable soils or concrete. Where soils are used, a suitable type of hard armor should be provided to prevent scour during overflow.

Where needed, forebay efficiency can often be increased by the proper use of flocculants. Manufacturer's recommendations should be strictly followed to maximize efficiency of the flocculant and prevent chemical contamination.

**STANDARD CONSTRUCTION DETAIL # 7-14  
Baffle**



PA DEP

**In pools with depths exceeding 7', the top of the plywood baffle does not need to extend to the temporary riser crest. Super Silt Fence baffles need not extend to TRCE elevation.**

NOTE: This table is intentionally blank and should be filled in by the plan preparer.

BASIN OR TRAP NO.	BAFFLE		TEMPORARY RISER	BOTTOM
	LENGTH Bal (FT)	HEIGHT Bah (FT)	CREST ELEV TRCE (FT)	BOTTOM ELEV BE (FT)

See appropriate basin detail for proper location and orientation.

Baffles shall be tied into one side of the basin unless otherwise shown on the plan drawings.

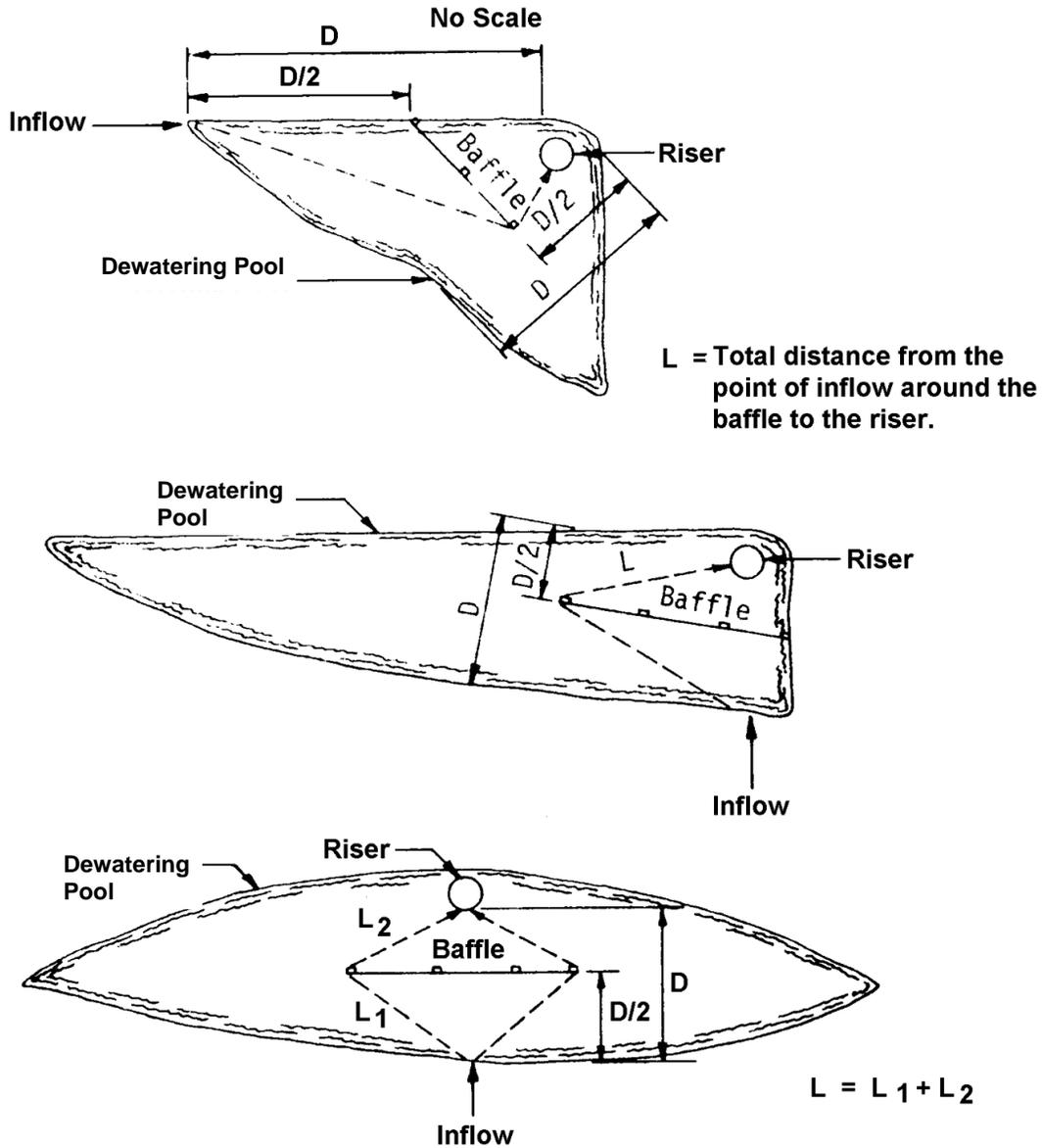
Substitution of materials not specified in this detail shall be approved by the Department or the local conservation district before installation.

Damaged or warped baffles shall be replaced within 7 days of inspection.

Baffles requiring support posts shall not be installed in basins requiring impervious liners.

**FIGURE 7.5**  
**Use of Baffles in Sediment Basins**

**EXAMPLE PLAN VIEWS OF BAFFLE LOCATIONS IN SEDIMENT BASINS**



USDA NRCS

Outlet Barrels

To avoid potential failure, outlet barrels should be installed early in the construction of the embankment rather than after the embankment is completed, and should drain to a stable receiving watercourse. Suitable outlet protection should be provided for all basin outfalls. Basins should not be constructed in locations where subsequent trenching for sewer lines and utilities will disturb the embankment.

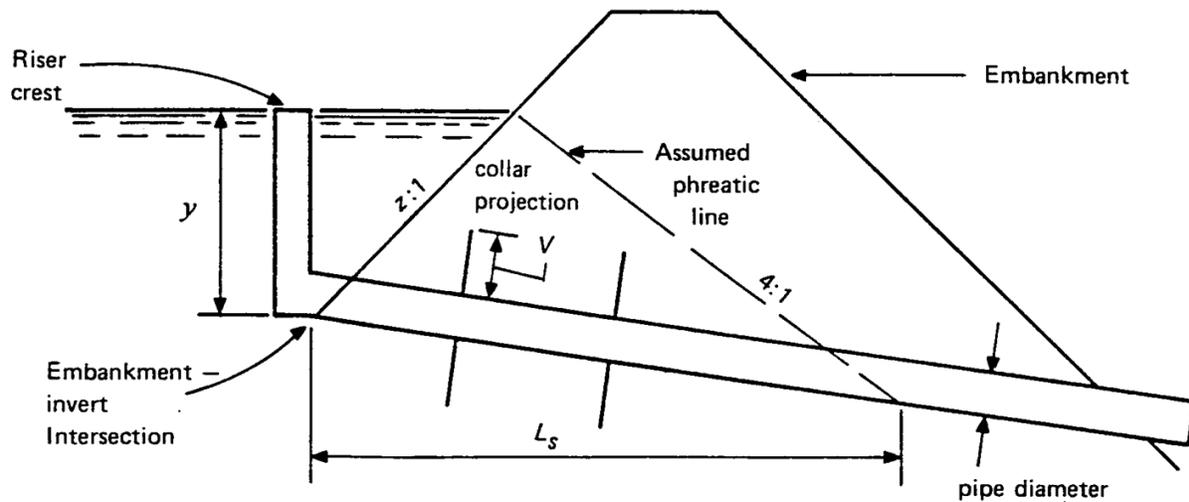
## Anti-seep Collar

Whenever soils susceptible to piping are encountered, anti-seep collars or filter diaphragms should be installed with the outlet barrel. Figure 7.6 shows the critical dimensions for design of anti-seep collars.



PA DEP

**FIGURE 7.6**  
**Anti-seep Collar Design**



EPA - 625/3-76-006

The following procedure may be used to determine the required increase in flow path by anti-seep collars.

1. Determine the length of pipe in the saturated zone ( $L_S$ ). See Figure 7.6.

$$L_S = y ( z + 4 ) \left[ 1 + \frac{\text{pipe slope (ft / ft)}}{0.25 - \text{pipe slope}} \right]$$

where:  $L_S$  = Length of pipe in saturated zone (ft)  
 $y$  = Distance from upstream invert of principal spillway riser to top of dewatering volume.  
 $Z$  = Horizontal component of upstream embankment slope (ft)

To determine  $L_S$  graphically, refer to Figure 7.7.

Example:  $y$  = 8 feet, embankment inside slope = 2.5:1, pipe slope = 10%

$$L_S = 87 \text{ feet}$$

2. Determine the required increase in flow path.
  - a. For a temporary basin, a minimum 10% increase should be provided.

$$L_F = 1.1 L_S = 1.1 \times 87 = 95.7 \text{ feet}$$

- b. For a permanent basin, a minimum of 15% should be provided.

$$L_F = 1.15 L_S = 1.15 \times 87 = 100 \text{ feet}$$

3. The minimum collar projection ( $V$ ) is equal to  $\frac{1}{2}$  the increase in flow length (for one collar). If more than one collar is used, it is the increase divided by twice the number of collars.

For 3 collars on a temporary basin in the example above:

$$V_{\min} = 8.7 \div 6 = 1.45 \cong 1.5 \text{ feet.}$$

For a permanent basin:

$$V_{\min} = 13 \div 6 = 2.17 \cong 2.25 \text{ feet.}$$

Conversely, the minimum number of collars with a given projection that are needed can be determined by the following equation:

$$N = \frac{(L_F - L_S)}{2V} \text{ for temporary and permanent basins}$$

Where  $N$  = Number of anti-seep collars  
 $V$  = Collar projection from pipe (ft)  
 $L_S$  = Length of flow in the saturated zone (ft)  
 $L_F$  = Required minimum length of flow in the saturated zone (ft)



4. The maximum spacing between collars should be  $14 \times V$  or  $L_s \div (\text{number of collars minus } 1)$ .

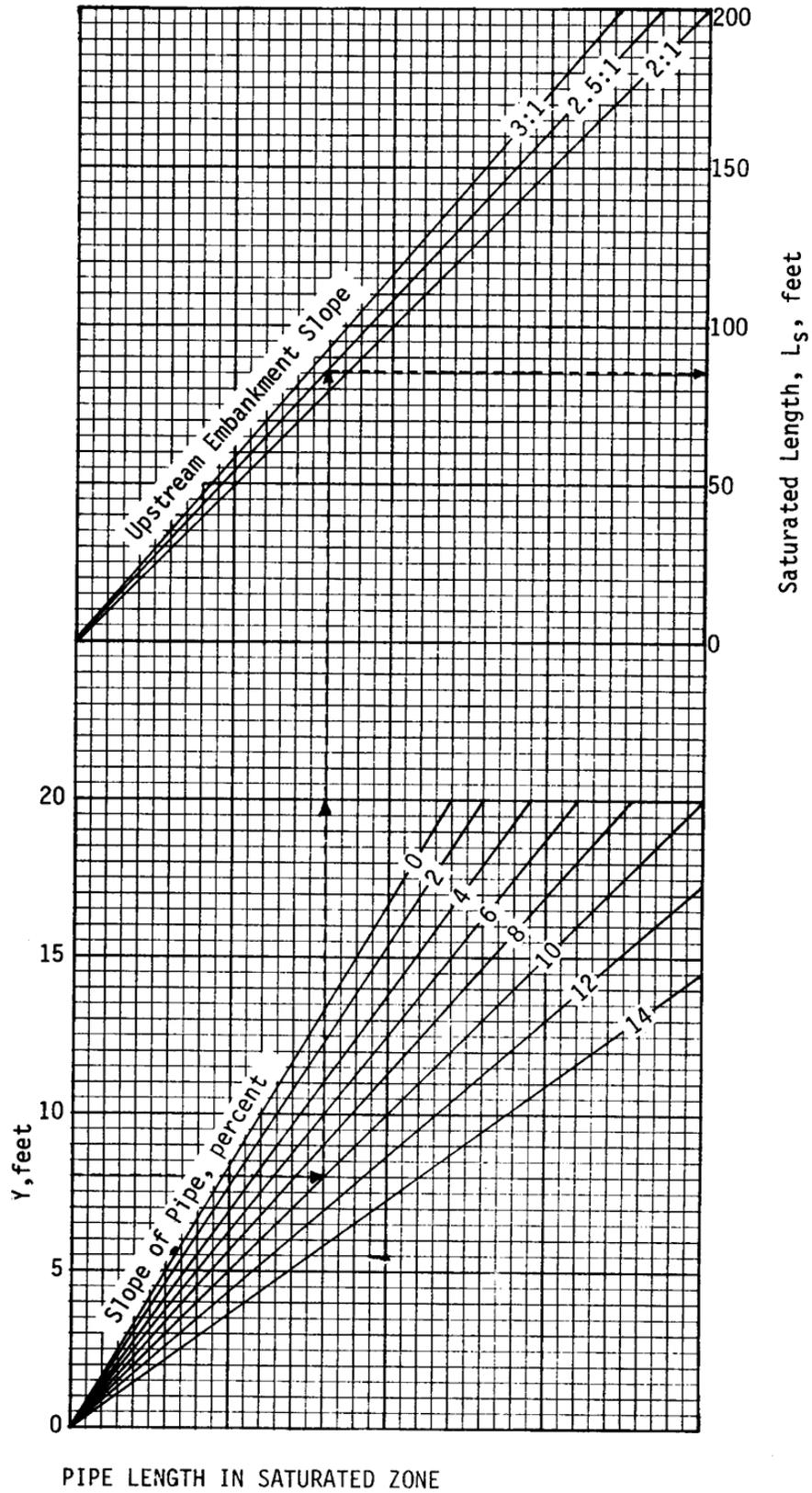
For the example temporary basin, the maximum spacing would be  $14 \times 3 = 42$  feet. This would use 84 feet of the 87 total for  $L_s$ .

Therefore, the maximum spacing for the example permanent basin would be 43.5 feet.

Minimum spacing should be  $5 \times V$ .

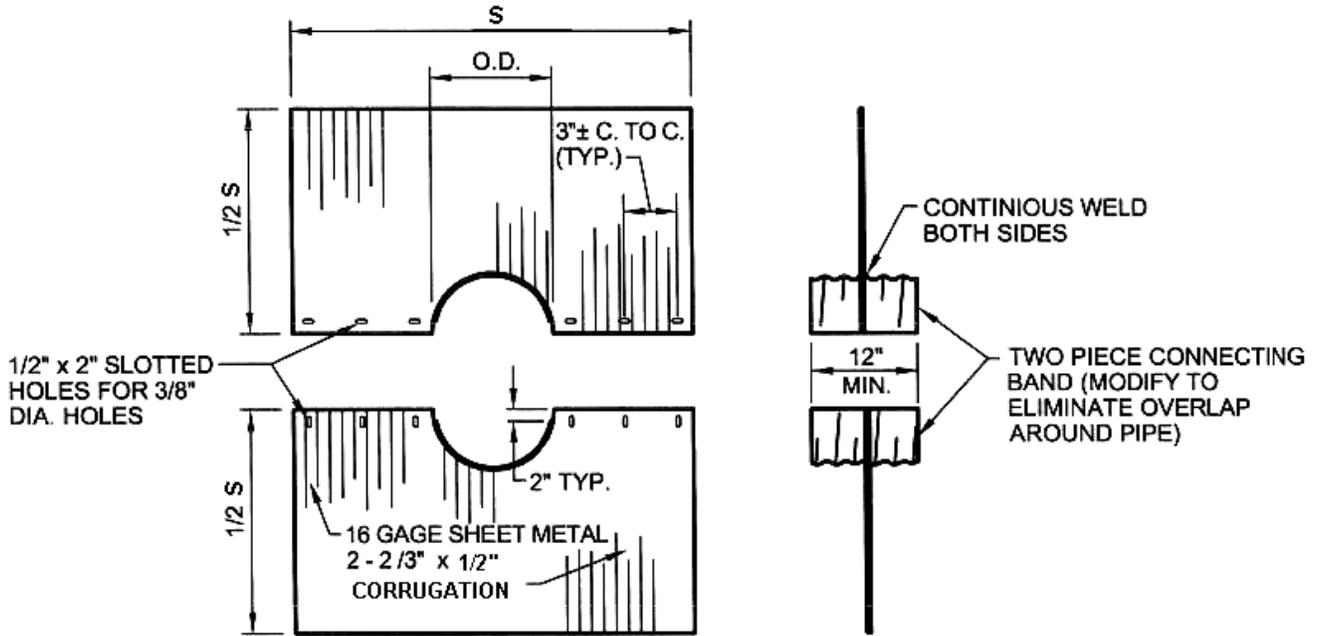
5. Anti-seep collars and their connections to the pipe, or barrel, should be watertight.
6. Anti-seep collars should be located below the phreatic line in the embankment and should be evenly spaced.
7. They should not be located closer than 2 feet to a pipe joint.
8. There should be sufficient distance between collars for hauling and compacting equipment.
9. Metal anti-seep collars may be used on temporary basins and should meet the standards of Standard Construction Detail #7-15. Plastic anti-seep collars may be an acceptable alternative. Concrete anti-seep collars should be used on permanent basins and should meet the standards of Standard Construction Detail #7-16. For most basins, the concrete anti-seep collar shown in PennDOT's RC-71M, dated 2008 is an acceptable alternative. Wood, fabric, and other degradable materials are not acceptable. Other nondegradable materials may be approved on a case-by-case basis.
10. The dimension of one side (S) of each collar is equal to  $2V + \text{Barrel diameter}$ .

**FIGURE 7.7**  
**Graphical Determination of Length of Pipe in the Saturated Zone ( $L_s$ )**



USDA NRCS

**STANDARD CONSTRUCTION DETAIL # 7-15  
Metal Anti-seep Collar for Temporary Basins or Traps**



Adapted from PennDOT RC-70

**Collar shall be of same gage and with same coating as pipe with which it is used. Install with corrugations vertical.**

**Minimum distance to pipe joint shall be 2 feet.**

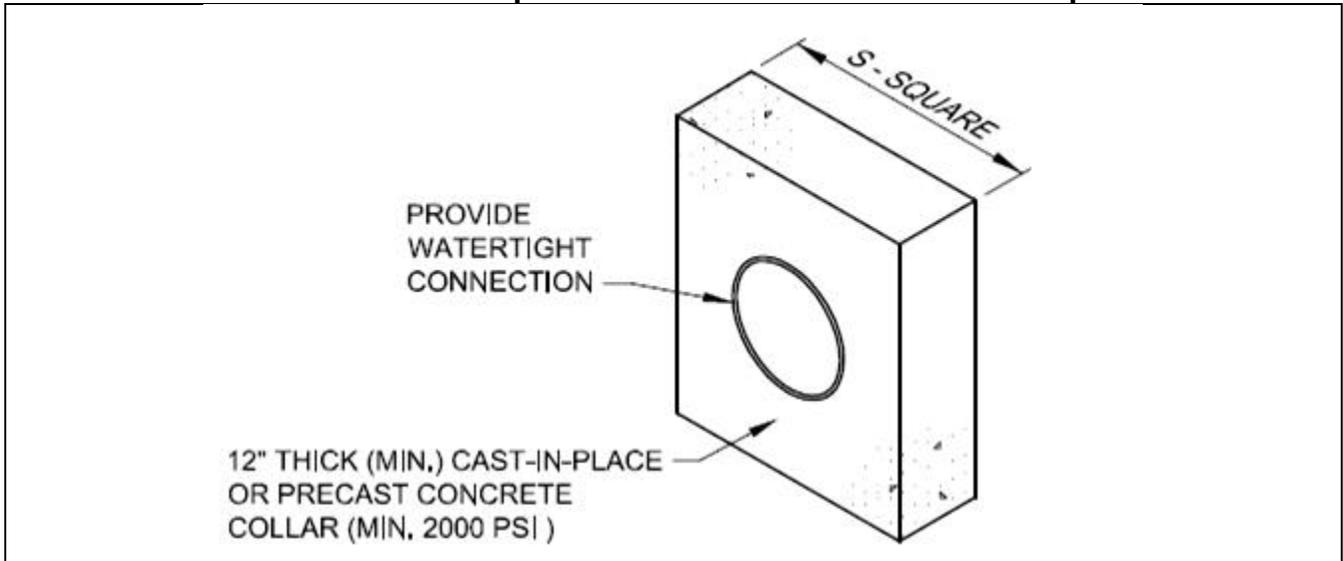
**All collars shall be installed so as to be watertight. The lap between the two half sections and between the pipe and connecting band shall be caulked with asphalt mastic at time of installation.**

**Collar size and spacing shall be as indicated below.**

NOTE: This table is intentionally blank and should be filled in by the plan preparer.

Basin or Trap No.	Pipe Size (in)	S (in)	No. of Collars	Distance Riser to 1 <sup>st</sup> Collar (ft)	Collar Spacing (ft)

**STANDARD CONSTRUCTION DETAIL # 7-16  
Concrete Anti-seep Collar for Permanent Basins or Traps**



Stackhouse Bensinger, Inc.

**All collars shall be installed so as to be watertight.**

**Collar size and spacing shall be as indicated below.**

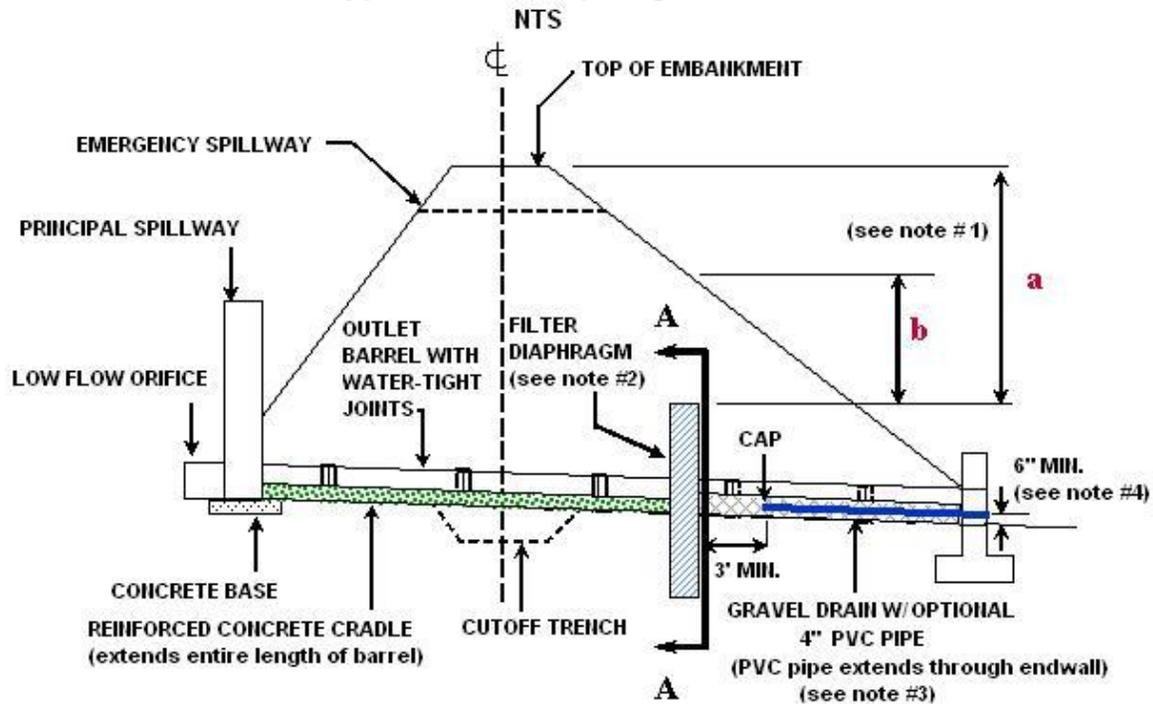
NOTE: This table is intentionally blank and should be filled in by the plan preparer.

<b>Basin or Trap No.</b>	<b>Pipe Size (in)</b>	<b>S (in)</b>	<b>No. of Collars</b>	<b>Distance Riser to 1<sup>st</sup> Collar (ft)</b>	<b>Collar Spacing (ft)</b>

## FILTER DIAPHRAGM

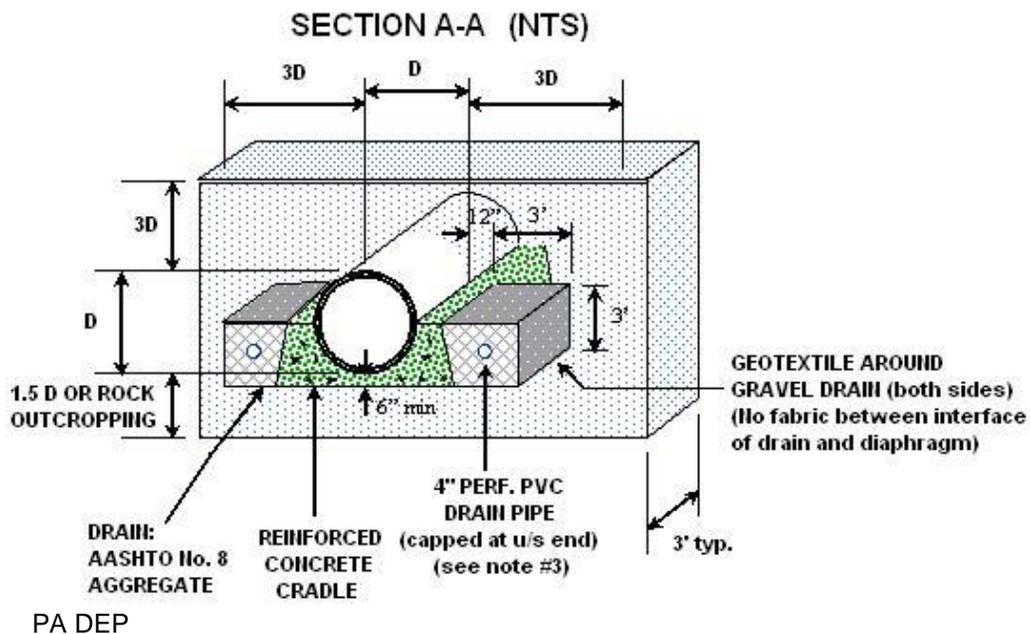
Filter diaphragms may be used in conjunction with anti-seep collars and/or a concrete cradle, as shown in Figure 7.8, or instead of these depending on soil conditions.

**FIGURE 7.8**  
**Typical Filter Diaphragm Installation**



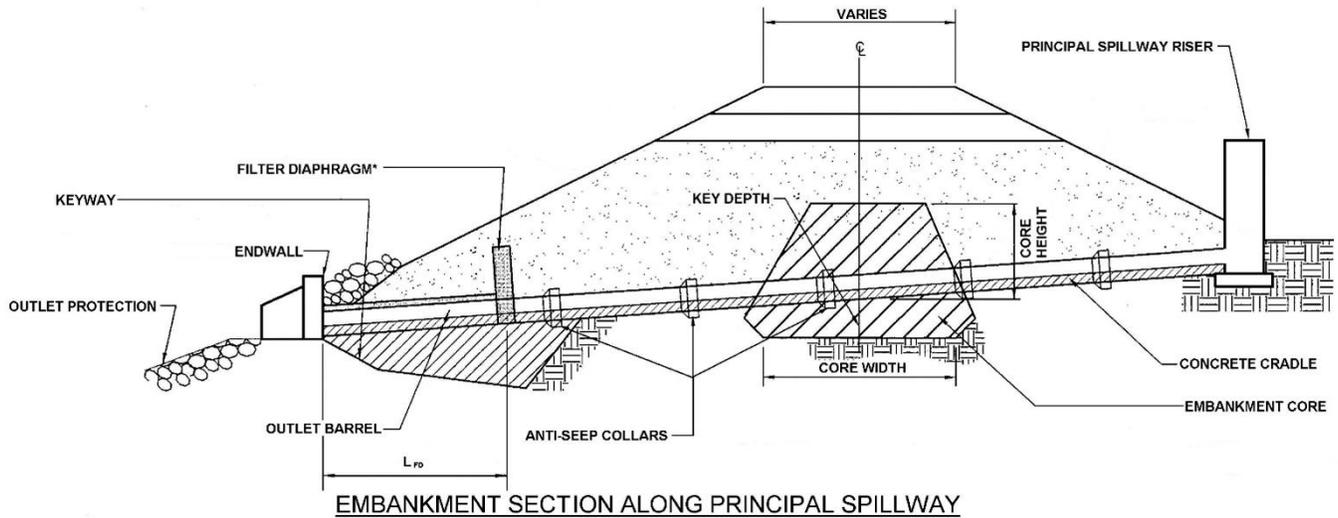
**Notes:**

1. Diaphragm should be located d/s of embankment centerline and cutoff trench and u/s of a point where  $b = 0.5 a$
2. Diaphragm should be constructed using a specially graded sand (Typically Type A concrete sand)
3. Optional drain pipe should have maximum  $3/16"$  perforations if used in AASHTO No. 8 drain.
4. Outlet of drain should be located at least 6" above invert of outlet conduit.

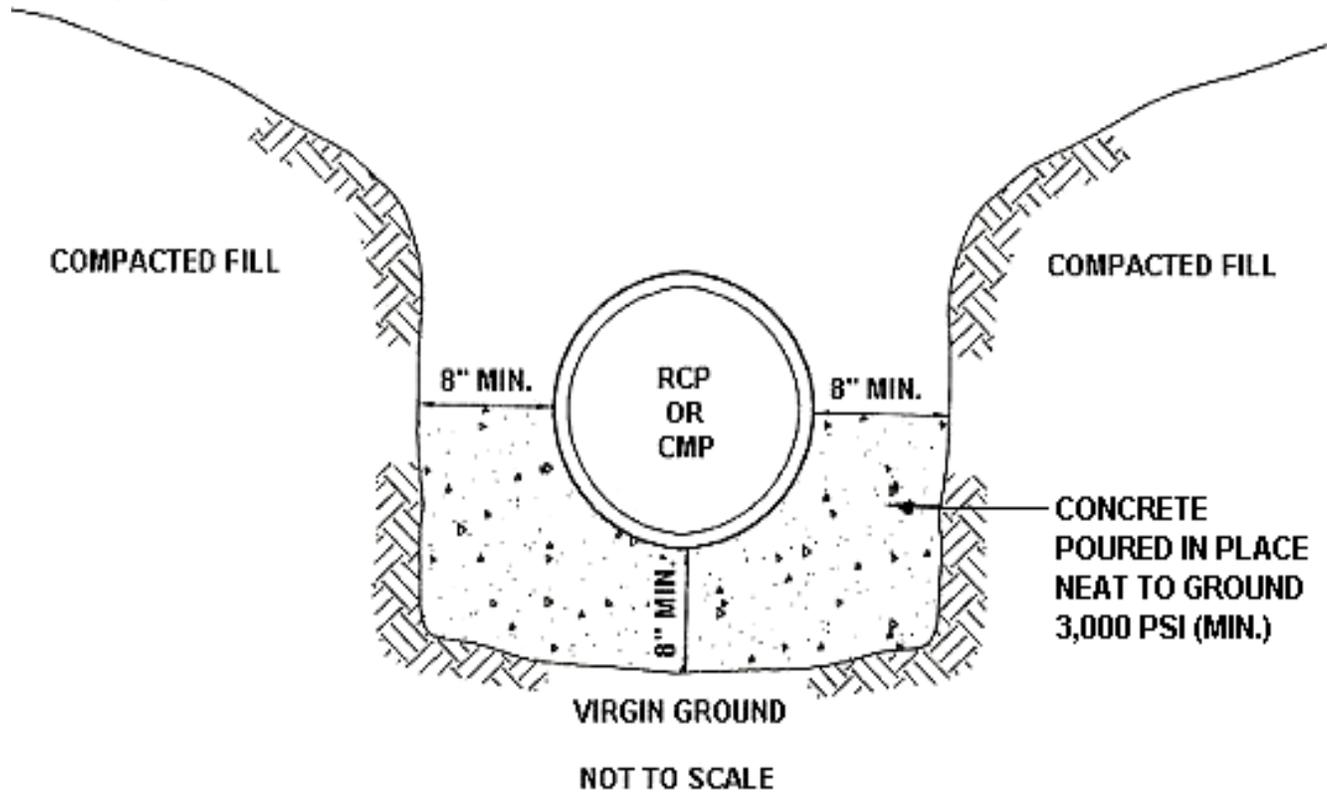


For additional information on filter diaphragm design, contact DEP's Bureau of Clean Water.

**STANDARD CONSTRUCTION DETAIL # 7-17  
Concrete Cradle for Basin or Trap Outlet Barrel**



**\*Where proposed**



Adapted from Westmoreland Conservation District

**Note:** A concrete cradle may be used in conjunction with anti-seep collars and/or filter diaphragm.

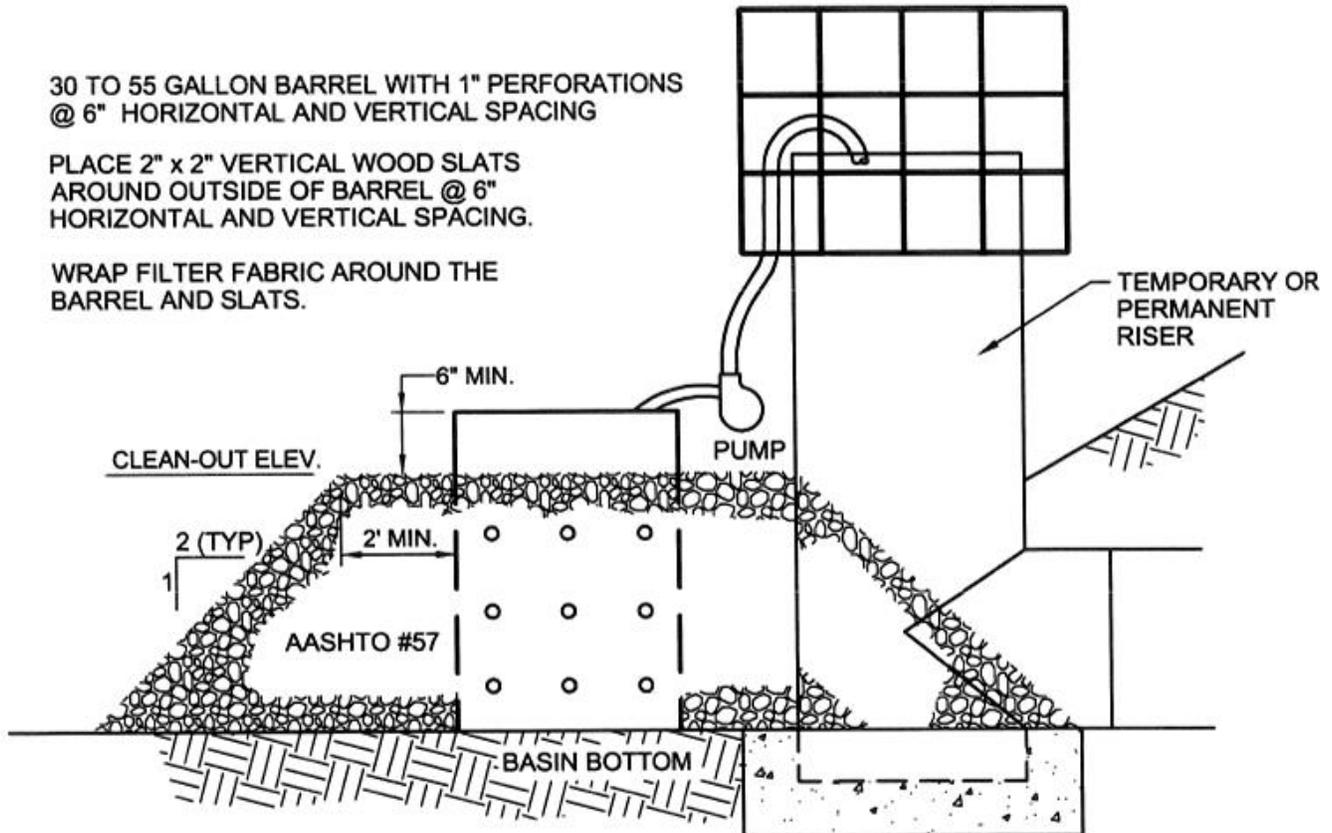
Anti-seep collar number, size and spacing shall be as shown elsewhere in plan.

Filter diaphragm location ( $L_{FD}$ ) shall be as shown in Figure 7.8.

## Sediment Storage Zone Dewatering

Prior to backfilling a sediment basin or converting it to a permanent stormwater facility, the sediment storage zone should be dewatered. This can be done by use of a dewatering facility such as the one shown in Standard Construction Detail #7-18, by pumping through a pumped water filter bag shown in Standard Construction Detail # 3-16, or by pumping to a nearby basin or trap as discussed in Dewatering Work Areas.

### **STANDARD CONSTRUCTION DETAIL # 7-18 Sediment Basin or Sediment Trap Sediment Storage Dewatering Facility**



PA DEP

**Dewatering facility shall be installed immediately upon completion of basin/trap.**

**Prior to initiating operation of dewatering facility, all accumulated sediment shall be cleaned from the inside of the barrel.**

**Dewatering facility shall be continuously monitored during operation. If for any reason the dewatering facility ceases to function properly, it shall be immediately shut down and not restarted until the problem has been corrected.**

Provide construction details for each proposed sediment basin on the E&S plans. The plan view should indicate the principal and emergency spillway locations, the inlets from all pipes and interceptor channels, and any proposed outlet protection. Also provide a construction detail of the principal and emergency spillways showing all critical dimensions and elevations. A summary table showing all critical dimensions and elevation for each basin is recommended for sites having more than one basin.

## CHAPTER 8 - SEDIMENT TRAPS

### GENERAL CONSIDERATIONS

Sediment Traps may be designed to function as temporary facilities, or incorporated into the Stormwater Management System upon completion of the project. In the latter case, the trap should be dewatered, cleaned, and stabilized prior to its conversion to a detention pond. Standard Construction Detail # 7-18, found in Chapter 7 - Sediment Basins, is a detail of a recommended "Sediment Basin or Sediment Trap Sediment Storage Dewatering Facility," which may be used for this purpose.

Field conditions, ease of construction, and trapping efficiency should be considered in choosing the configuration of a sediment trap. There are, however, certain design requirements that should be satisfied for all sediment traps. Standard E&S Worksheet # 19, Sediment Trap Design Data, should be used for organizing and submitting sediment trap data.

Wherever possible, sediment traps should be located below all proposed areas of disturbance. Locating traps within proposed grading areas typically results in a major portion of the earthmoving taking place without benefit of the trap being in place that was designed to handle runoff from the disturbed areas. Collector channels should enter a trap on the upslope side so that they do not adversely affect the storage capacity of the trap.

Consideration should be given to how the location of any proposed trap will be accessed. If a proposed location is not easily accessible, special attention should be given to any access roads that will need to be constructed, as in Chapter 3 on Site Access.

Intersection of a trap by proposed or existing sewer lines, utility lines, roadways, or other structures should be avoided wherever possible. Wherever this is not possible, the plan should address how the integrity/capacity of the trap will be maintained.

Location of traps on steep slopes or on unstable soils should be avoided wherever possible. Where this is not possible, the plan should address how failure of the trap will be avoided. Sediment traps may not be located within stream channels or in wetlands.

Compost filter sock traps may be used for some locations where a temporary sediment trap would be used as long as the installation procedure for such a trap is followed and the type of sock used is suitable for the length of time the trap will be in use. For more information about these types of sediment traps, see Chapter 3 on Site Access.

### DESIGN CRITERIA

1. The maximum permissible drainage area is 5.0 acres.
2. Access to proposed and existing traps should be provided in accordance with the standards provided in Chapter 3. Such accesses should be maintained for the life of the trap. When no longer needed, accesses should be regraded and stabilized in accordance with Chapter 11 – Stabilization Methods and Standards.
3. Sediment traps should have a minimum storage volume of 2,000 cubic feet for each acre of contributing drainage area (disturbed and undisturbed), 700 cubic feet/acre should be considered sediment storage, and 1,300 cubic feet/acre should be considered dewatering zone. Supporting computations should be provided for irregularly shaped traps — Standard E&S Worksheet #14 is recommended for this purpose.



4. Greater surface area increases the trapping efficiency of a sediment trap. For sediment traps located in fine-textured soils (e.g. sandy clay, silty clay, silty clay loam, clay loam, and clay), the minimum surface area in square feet of the storage volume should be 5,300 times the number of contributory drainage acres. For example, a trap with a 5 acre drainage area would need 26,500 square feet of surface area. A trap with a storage volume surface area of approximately 115' X 230' would meet this requirement. Where this is not possible, consideration should be given to the use of a soil stabilizer or compost on disturbed surfaces or using a sediment forebay or a turbidity curtain to increase trap efficiency.
5. Sediment Traps which will be converted into infiltration basins should be constructed in compliance with the Pennsylvania Stormwater Best Management Practices Manual.
6. A stone berm similar to that shown in Standard Construction Detail # 7-3 is recommended for traps that will be converted to stormwater basins. The volume of the berm should be subtracted from the calculated storage volume of the trap.
7. A minimum flow length to width ratio of 4L:1W should be provided for all traps located in special protection watersheds (HQ or EV). A minimum ratio of 2:1 should be provided for all other traps. Minimum length (L) of flow through a trap is 10 feet unless the trap is constructed around an inlet structure. If baffles are needed to achieve this flow length to width ratio, Figure 7.5 and Standard Construction Detail # 7-14 in Chapter 7 may be used for their design. An acceptable alternative is the use of a sediment forebay or turbidity curtain.
8. Sediment traps should discharge to stable, erosion resistant areas and not create offsite stormwater problems. Wherever a trap must discharge down a long or steep slope, consideration should be given to using a barrel/riser or skimmer type spillway in conjunction with a temporary slope pipe. Suitable outlet protection should be provided at the pipe outfall. **NOTE: Any trap not outletting directly to a waterway should not increase rate of runoff onto an adjoining property without an easement from the property owner. Supporting evidence should be provided to show that the discharge will not cause accelerated erosion.**
9. Minimum trap storage depth is 2.0 feet. (Minimum 1' for sediment and 1' minimum for dewatering zone)
10. Traps should be able to dewater the dewatering zone completely. Wherever total dewatering is desired, adequate filtering should be provided.
11. Maximum constructed embankment height is 5.0 feet unless the berm is constructed as a permanent stormwater management basin with a corresponding increase in top width. For any sediment trap that will be converted to a permanent stormwater facility, consideration should be given to whether a key trench is needed. See Chapter 7 for more information regarding key trenches.
12. Minimum embankment top width is 5.0 feet.
13. Maximum embankment side slopes are 2H:1V.
14. Minimum freeboard above maximum design water level is 12 inches.

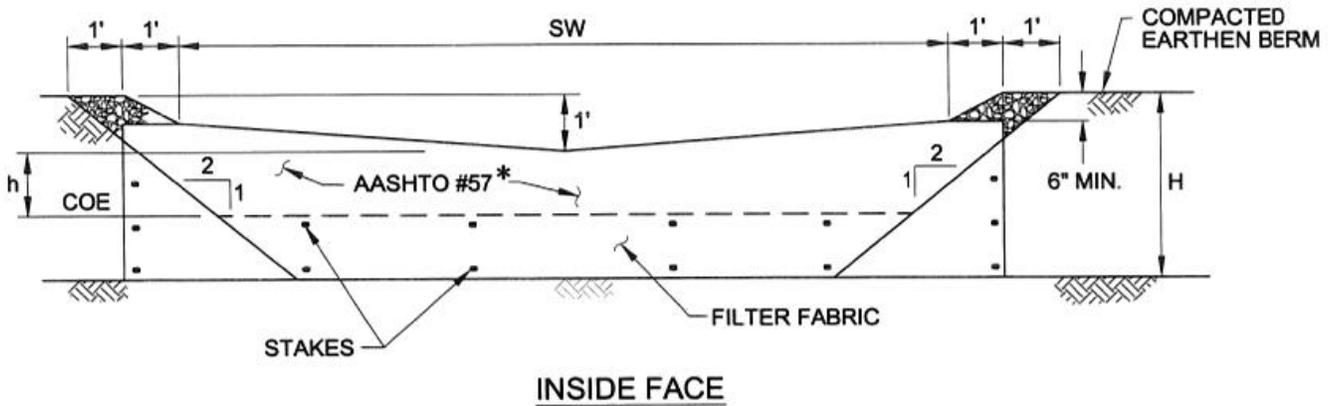
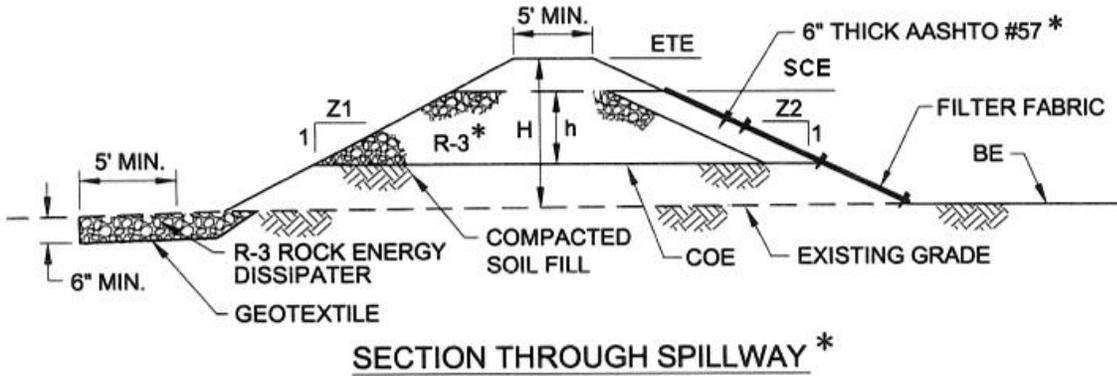
Embankment Sediment Trap - This device has **LOW** sediment removal efficiency and is not an **ABACT** for special protection watersheds. However, sediment removal efficiency can be raised to **MODERATE** by adding a 6" layer of compost on the inside face of the spillway and anchoring it with a suitable netting. In that case it would be an **ABACT** for HQ watersheds. A **HIGH** efficiency rating — **ABACT** for HQ and EV watersheds — may be obtained by replacing the filter cloth with 24" diameter compost socks staked across the inside face of the spillway.



York County Conservation District

For traps with embankment spillways, the minimum embankment spillway width (in feet) is 2 times the number of acres of contributing drainage area. If not discharging directly into a waterway, the minimum spillway width (feet) should be 6 times the number of contributory drainage acres. The minimum spillway crest elevation is the elevation at which the required 2,000 cubic feet per contributing drainage acre storage capacity is provided. The maximum spillway side slope is 2H:1V. The minimum rock size for construction of the spillway is R-3. R-4 or larger rock is recommended for drainage areas greater than 3.0 acres. The entire spillway should be constructed with rock — above the clean out elevation, (see Standard Construction Detail # 8-1). The inside face of the spillway should be covered with a 6" (minimum) thick layer of filter stone (maximum size = AASHTO #57). Filter fabric should be securely staked on top of the filter stone up to the top of the spillway. Any excess fabric should be staked to the bottom of the trap.

**STANDARD CONSTRUCTION DETAIL # 8-1  
Embankment Sediment Trap**



PA DEP

Embankment outlet shall be composed entirely of rock above clean out elevation (COE); main body R-3 or larger — R-4 to be used for drainage areas greater than 3.0 acres, inside face AASHTO # 57 stone or smaller. A 6" thick layer of compost, compost sock, or clean sand shall be installed on top of the AASHTO #57 stone and securely anchored in HQ watersheds. 24" diameter compost sock(s) shall be used in place of filter fabric and AASHTO #57 stone in EV watersheds.

Fill material for the embankments shall be free of roots, or other woody vegetation, organic material, large stones, and other objectionable materials. The embankment shall be compacted in layered lifts of not more than 9". The maximum rock size shall be no greater than 6".

Upon completion, the embankment shall be seeded and mulched or otherwise stabilized according to the specifications of the E&S plan drawings.

All sediment traps shall be inspected at least weekly and after each runoff event.

Access for sediment removal and other required maintenance activities shall be provided.

A clean out stake shall be placed near the center of each trap. Accumulated sediment shall be removed when it has reached the clean out elevation on the stake and the trap restored to its original dimensions. Dispose of materials removed from the trap in the manner described in the E&S Plan.

Check embankments, spillways, and outlets for erosion, piping and settlement. Clogged or damaged spillways and/or embankments shall be immediately restored to the design specifications.

Displaced riprap within the spillway or outlet protection shall be replaced immediately.

Accumulated sediment shall be removed and disturbed areas inside the trap shall be stabilized before conversion to a stormwater management facility. To assist in removing sediment, which may be saturated, a device such as is shown in Standard Construction Detail #7-18 may be used to dewater the sediment prior to its removal.

NOTE: This table is intentionally blank and should be filled in by the plan preparer.

TRAP NO.	Z1 (FT)	Z2 (FT)	H (FT)	h (FT)	EMBANK. TOP ELEV. ETE (FT)	SPILLWAY CREST ELEV. SCE (FT)	CLEAN OUT ELEV. COE (FT)	BOTTOM ELEV. BE (FT)	SPILLWAY WIDTH SW (FT)

Barrel/Riser Sediment Trap - This device has MODERATE sediment removal efficiency and is an ABACT for HQ watersheds but not for EV watersheds. The efficiency can be raised to HIGH, meeting ABACT for HQ and EV watersheds, by substituting a skimmer dewatering device for the perforated riser.



PA DEP

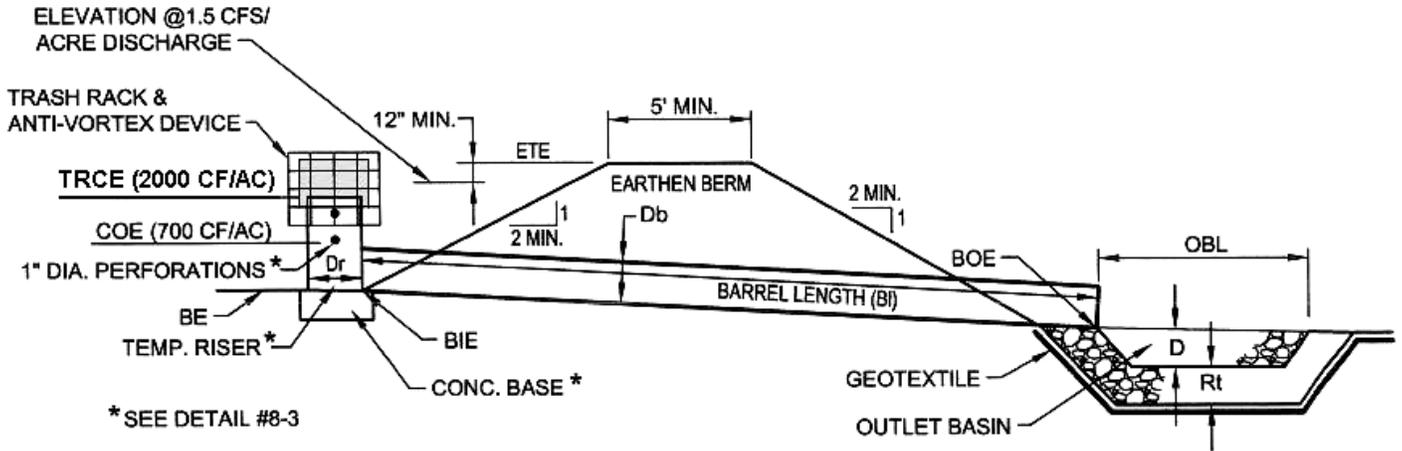
For traps with barrel/riser spillways, the crest of the riser should be set at the elevation at which the required 2,000 cubic feet/acre storage capacity is provided. The riser and outlet barrel should be sized to provide a discharge capacity of 1.5 cfs/acre. Recommended minimum barrel and riser diameters are contained in Table 8.1. Supporting calculations should be provided. The embankment should provide at least 12" of freeboard above the maximum design water elevation — the elevation at which the 1.5 cfs/acre discharge capacity is provided. Perforations in the riser to dewater the trap should be limited to one 1" diameter hole per vertical foot of riser with the lowest perforation at the sediment storage elevation as shown in Standard Construction Detail # 8-2.

**TABLE 8.1**  
**Recommended Minimum Pipe Sizes for Barrel/Riser Sediment Traps**

Barrel Diameter (in.)	Riser Diameter (in.)	Drainage Area (Acres)
12	15	1
15	18	2
18	21	3
21	24	4
21	27	5

New York DEC

## STANDARD CONSTRUCTION DETAIL # 8-2 Barrel/Riser Sediment Trap



PA DEP

NOTE: This table is intentionally blank and should be filled in by the plan preparer.

Trap NO.	Z1 (FT)	Z2 (FT)	RISER			BARREL				EMBANKMENT		CLEAN OUT ELEV COE (FT)	BOTTOM ELEV BE (FT)
			MAT'L	DIA Dr (IN)	CREST ELEV TRCE (FT)	BOT. PERF. ELEV (FT)	MAT'L	DIA Db (IN)	INLET ELEV BIE (FT)	LENGTH BI (FT)	OUTLET ELEV BOE (FT)		

TRAP NO.	CONCRETE BASE			OUTLET BASIN				
	LENGTH CBI (IN)	WIDTH CBw (IN)	THICKNESS CBt (IN)	RIPRAP SIZE (R-___)	Rock Thickness Rt (IN)	DEPTH D (IN)	WIDTH OBW (FT)	LENGTH OBL (FT)

Fill material for the embankments shall be free of roots, or other woody vegetation, organic material, large stones, and other objectionable materials. The embankment shall be compacted in layered lifts of not more than 6" to 9". The maximum rock size shall be no greater than 2/3 the lift thickness.

Upon completion, the embankment shall be seeded and mulched or otherwise stabilized according to the specifications of the E&S plan drawings.

All sediment traps shall be inspected at least weekly and after each runoff event.

Access for sediment removal and other required maintenance activities shall be provided.

A clean out stake shall be placed near the center of each trap. Accumulated sediment shall be removed when it has reached the clean out elevation on the stake and the trap restored to its original dimensions. Dispose of materials removed from the trap in the manner described in the E&S plan.

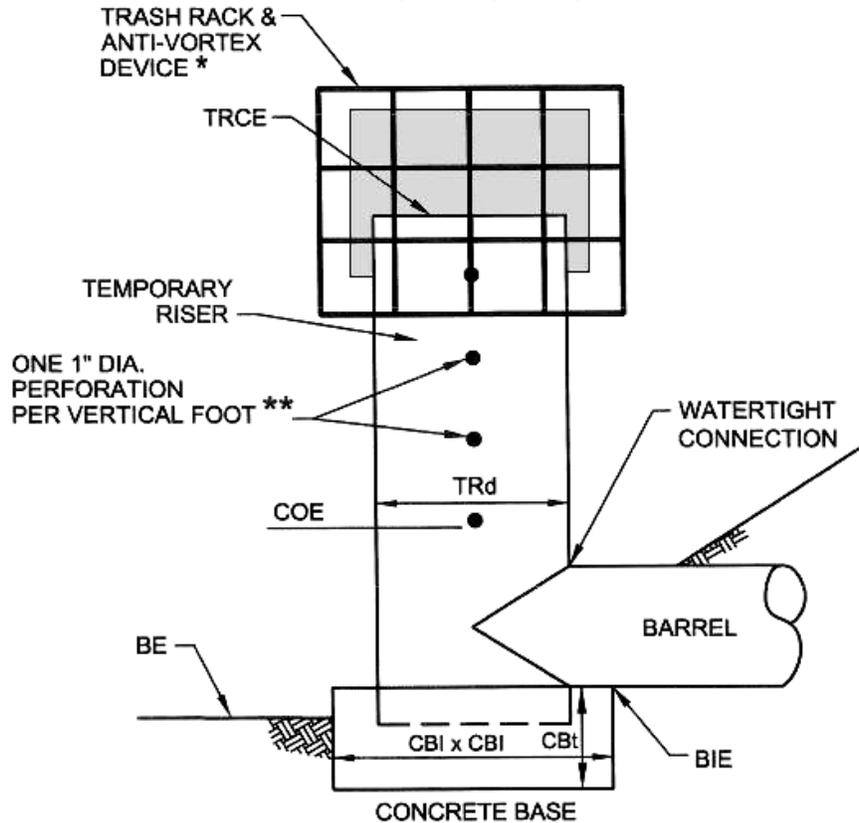
Check embankments, spillways, and outlets for erosion, piping and settlement. Clogged or damaged spillways and/or embankments shall be immediately restored to the design specifications.

Displaced riprap within the outlet protection shall be replaced immediately.

**Accumulated sediment shall be removed and disturbed areas inside the trap shall be stabilized before conversion to a stormwater management facility. To assist in removing sediment, which may be saturated, a device such as is shown in Standard Construction Detail #7-18 may be used to dewater the sediment prior to its removal.**

## STANDARD CONSTRUCTION DETAIL #8-3

### Sediment Trap Temporary Riser



- \* SEE TRASH RACK & ANTI-VORTEX DEVICE DETAIL
- \*\* LOWEST HOLE AT SEDIMENT CLEAN-OUT ELEVATION  
PA DEP

NOTE: This table is intentionally blank and should be filled in by the plan preparer.

TRAP NO.	TEMPORARY RISER				CONCRETE BASE			BARREL
	DIA TRd (IN)	CREST ELEV TRCE (FT)	MAT'L	CLEAN OUT ELEV COE	LENGTH CBI (IN)	WIDTH CBw (IN)	THICK CBt (IN)	INLET ELEV BIE (FT)

**Clogged or damaged spillways shall be repaired immediately. Trash and other debris from the trap and riser shall be removed.**

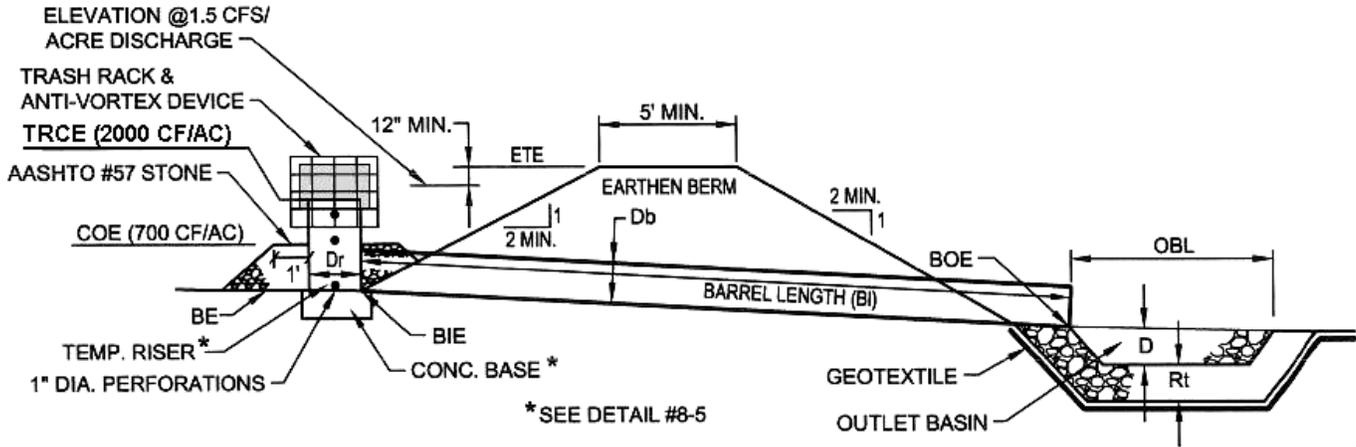
**Place a minimum of 2 #8 rebar at right angles and projecting through sides of riser to anchor it to concrete base. Rebar shall project a minimum of ¼ riser diameter beyond outside of riser.**

**Concrete base shall be poured in such a manner as to insure that concrete fills bottom of riser to invert of the outlet pipe to prevent riser from breaking away from the base. Minimum base width equals 2 times riser diameter.**

**Embedded section of aluminum or aluminized pipe shall be painted with zinc chromate or equivalent.**



## STANDARD CONSTRUCTION DETAIL # 8-4 Dry Barrel/Riser Sediment Trap



PA DEP

NOTE: This table is intentionally blank and should be filled in by the plan preparer.

TRAP NO.	Z1 (FT)	Z2 (FT)	RISER				BARREL				EMBANK TOP ELEV ETE (FT)	CLEAN OUT ELEV COE (FT)	BOTT'M ELEV BE (FT)	
			MAT'L	DIA Dr (IN)	CREST ELEV TRCE (FT)	BOT. PERF. ELEV (FT)	MAT'L	DIA Db (IN)	INLET ELEV BIE (FT)	LENGTH BI (FT)				OUTLET ELEV BOE (FT)

TRAP NO.	CONCRETE BASE			OUTLET BASIN				
	LENGTH CBI (IN)	WIDTH CBw (IN)	THICKNESS CBt (IN)	RIPRAP SIZE (R-___)	ROCK THICKNESS Rt (IN)	DEPTH D (IN)	WIDTH OBW (FT)	LENGTH OBL (FT)

In special protection — HQ or EV — watersheds, add 6" layer of compost on top of stone or replace stone with suitable compost filter sock.

Fill material for the embankments shall be free of roots, or other woody vegetation, organic material, large stones, and other objectionable materials. The embankment shall be compacted in layered lifts of not more than 6" to 9". The maximum rock size shall be no greater than 2/3 the lift thickness.

Upon completion, the embankment shall be seeded, mulched, and blanketed or otherwise stabilized according to the specifications of the E&S plan drawings.

All sediment traps shall be inspected at least weekly and after each runoff event.

Access for sediment removal and other required maintenance activities shall be provided.

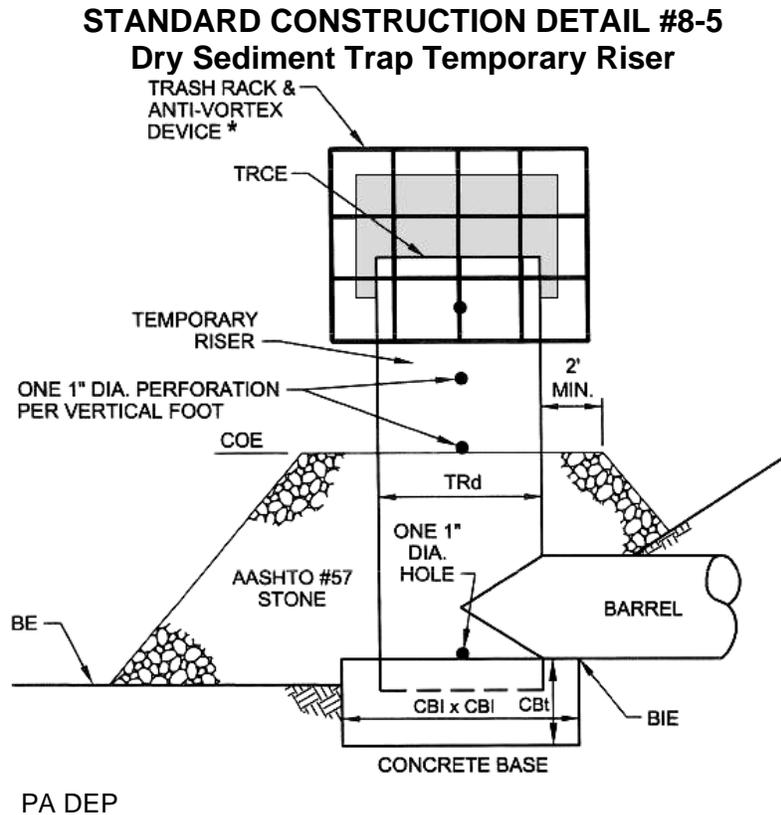
A clean out stake shall be placed near the center of each trap. Accumulated sediment shall be removed when it has reached the clean out elevation on the stake and the trap restored to its original dimensions. Dispose of materials removed from the trap in the manner described in the E&S plan.

Check embankments, spillways, and outlets for erosion, piping and settlement. Clogged or damaged spillways and/or embankments shall be immediately restored to the design specifications.

Displaced riprap within the outlet protection shall be replaced immediately.

**Accumulated sediment shall be removed and disturbed areas inside the trap shall be stabilized before conversion to a stormwater management facility. To assist in removing sediment, which may be saturated, a device such as is shown in Standard Construction Detail #7-18 may be used to dewater the sediment prior to its removal.**

Wherever total trap dewatering is required, one 1" diameter hole should be located at the bottom of the riser and a 2' thick layer of AASHTO #57 stone placed around the riser up to the top of the sediment storage zone. Filter cloth wrapped around the riser is not an acceptable alternative due to the potential for clogging. **A dry sediment trap riser has low sediment removal efficiency. It is not an ABACT for special protection watersheds. However, the efficiency can be raised to MODERATE by anchoring a 6" layer of compost around the outside of the AASHTO #57 stone.**



NOTE: This table is intentionally blank and should be filled in by the plan preparer.

TRAP NO.	TEMPORARY RISER				CONCRETE BASE			BARREL
	DIA TRd (IN)	CREST ELEV TRCE (FT)	MAT'L	CLEAN OUT ELEV COE	LENGTH CBI (IN)	WIDTH CBw (IN)	THICK CBT (IN)	INLET ELEV BIE (FT)

\* See Standard Construction Detail #7-5, Trash Rack and Anti-vortex Device.

**Clogged or damaged spillways shall be repaired immediately. Trash and other debris from the trap and riser shall be removed.**

**In special protection watersheds, anchor a 6" layer of compost shall be securely anchored on top of stone (HQ) or replace stone with suitable compost filter sock (HQ or EV).**

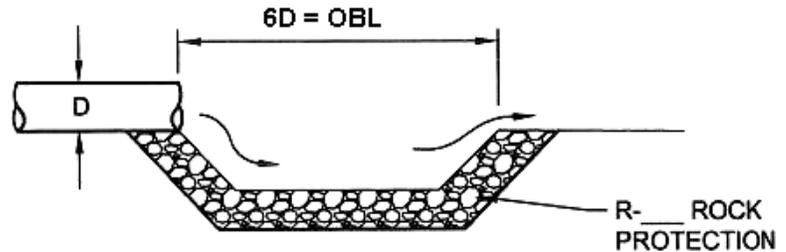
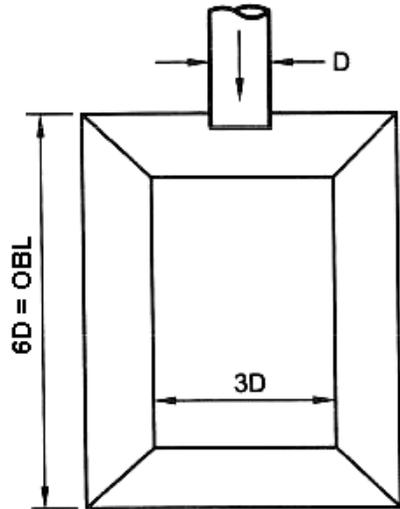
**Place a minimum of 2 #8 rebar at right angles and projecting through sides of riser to anchor it to concrete base. Rebar shall project a minimum of 1/4 riser diameter beyond outside of riser.**

**Concrete base shall be poured in such a manner as to insure that concrete fills bottom of riser to invert of the outlet pipe to prevent riser from breaking away from the base. Minimum base width equals 2 times riser diameter.**

**Embedded section of aluminum or aluminized pipe shall be painted with zinc chromate or equivalent.**

At a minimum, outlet protection should consist of a rock outlet basin with dimensions conforming to those shown in Standard Construction Detail #8-6. An acceptable alternative is a riprap apron designed according to the dimensions derived from Figure 9.3 or Figure 9.4. Where excessive discharge velocity is a problem, consideration should be given to use of a drop inlet structure or other velocity reduction device prior to outletting to the basin or apron.

### STANDARD CONSTRUCTION DETAIL # 8-6 Sediment Trap Outlet Basin Detail



**NOTE:**  
BASIN DEPTH = D  
BASIN MUST BE OVEREXCAVATED BY  
MAXIMUM STONE SIZE TO ALLOW  
FOR RIPRAP PLACEMENT

Adapted from EPA-625/3-76-006

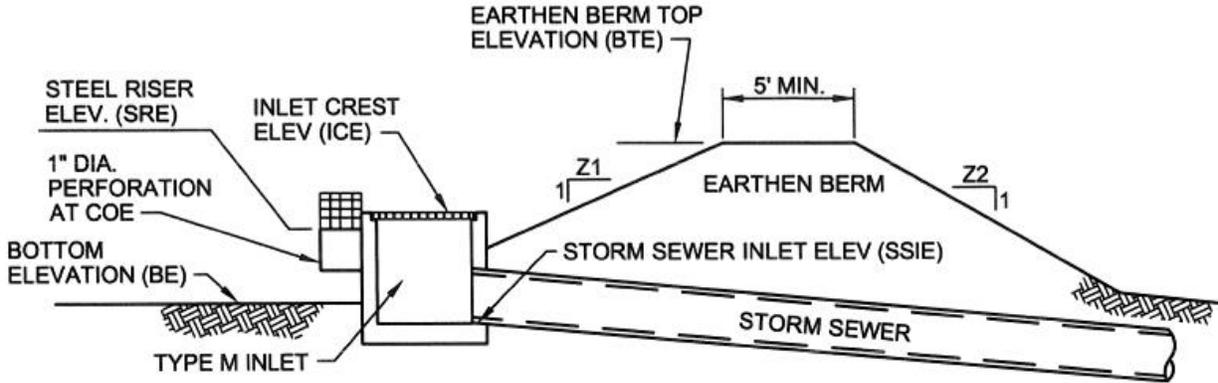
**All sediment trap outlet basins shall be inspected on at least a weekly basis and after each runoff event.**

**Displaced riprap within the outlet basin shall be replaced immediately.**

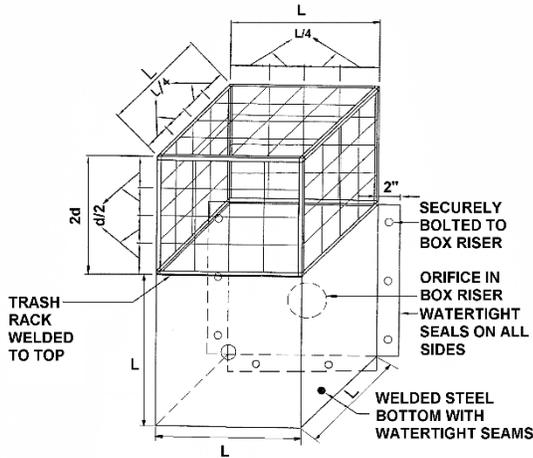
**Side slopes shall not exceed 1.5H:1V.**

# STANDARD CONSTRUCTION DETAIL # 8-7

## Type M Inlet Sediment Trap



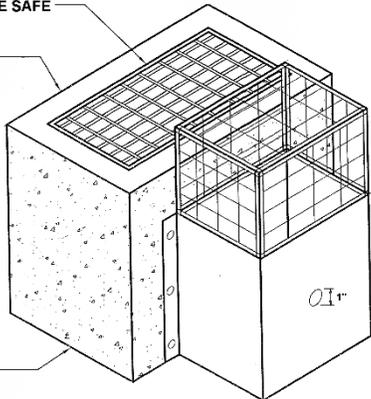
PA DEP



**FABRICATED STEEL RISER DETAIL**

STRUCTURAL STEEL GRATE BICYCLE SAFE

CONCRETE TYPE "M" INLET TOP UNIT WITH 2' X 4' OPENING



**TYPE M INLET WITH E & S RISER DETAIL**

Fill material for the berm shall be free of roots, or other woody vegetation, organic material, large stones, and other objectionable materials. The berm shall be compacted in layered lifts of not more than 6" to 9". The maximum rock size shall be no greater than 2/3 the lift thickness. Elevation BTE shall be minimum 24" above inlet crest elevation (ICE).

Upon completion, the berm shall be seeded, mulched, blanketed or otherwise stabilized according to the specifications of the E&S plan drawings. All sediment traps shall be inspected at least weekly and after each runoff event.

Access for sediment removal and other required maintenance activities shall be provided.

A clean out stake shall be placed near the center of each trap. Accumulated sediment shall be removed when it has reached the clean out elevation on the stake and the trap restored to its original dimensions. Dispose of materials removed from the trap in the manner described in the E&S plan.

Check berms for erosion, piping and settlement. Clogged or damaged inlets shall be immediately restored to the design specifications.

Remove accumulated sediment and stabilize disturbed areas inside the trap before conversion to a stormwater management facility.

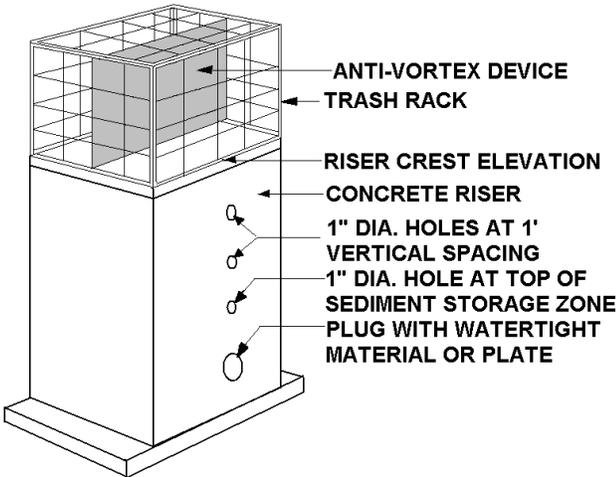
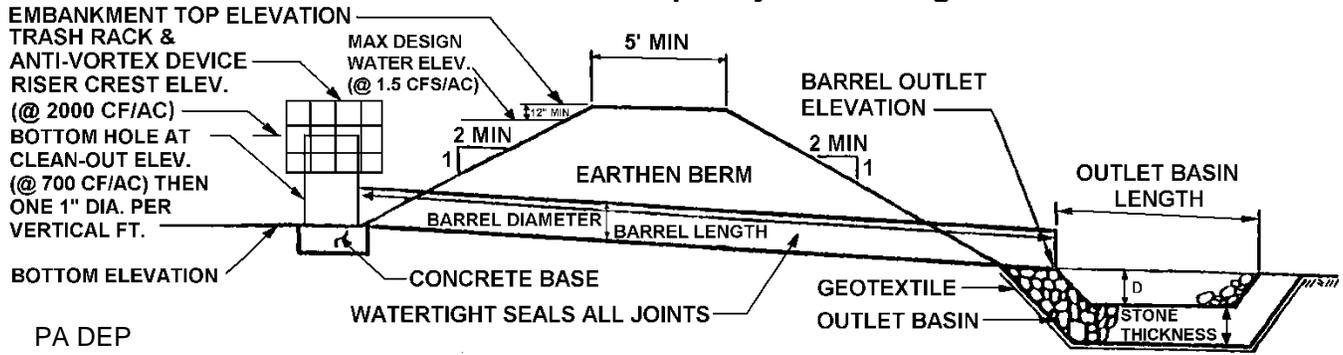
NOTE: This table is intentionally blank and should be filled

in by the plan preparer.

TRAP NO.	Z1 (FT)	Z2 (FT)	RISER		MAT'L	BARREL			OUTLET ELEV. BOE (FT)	EMBANKMENT		CLEAN OUT ELEV. COE (FT)	BOTTOM ELEV. BE (FT)
			BOT. PERF. ELEV. (FT)	CREST ELEV. (FT)		DIA. Db (IN)	INLET ELEV. BIE (FT)	LENGTH BI (FT)		TOP ELEV. ETE (FT)	TOP WIDTH ETW (FT)		

**STANDARD CONSTRUCTION DETAIL # 8-8**

**Concrete Riser with Temporary Dewatering Holes**



Fill material for the berm shall be free of roots, or other woody vegetation, organic material, large stones, and other objectionable materials. The berm shall be compacted in layered lifts of not more than 6" to 9". The maximum rock size shall be no greater than 2/3 the lift thickness.

Upon completion, the berm shall be seeded, mulched, blanketed or otherwise stabilized according to the specifications of the E&S plan drawings.

All sediment traps shall be inspected at least weekly and after each runoff event.

Access for sediment removal and other required

maintenance activities shall be provided.  
PA DEP

A clean out stake shall be placed near the center of each trap. Accumulated sediment shall be removed when it has reached the clean out elevation on the stake and the trap restored to its original dimensions. Dispose of materials removed from the trap in the manner described in the E&S plan.

Check berms for erosion, piping and settlement. Clogged or damaged inlets shall be immediately restored to the design specifications. Accumulated sediment shall be removed and disturbed areas inside the trap shall be stabilized before conversion to a stormwater management facility. Anti-vortex device is optional for this trap.

NOTE: This table is intentionally blank and should be filled in by the plan preparer.

TRAP NO.	Z1 (FT)	Z2 (FT)	RISER		BARREL				EMBANKMENT		CLEAN OUT ELEV. COE (FT)	BOTTOM ELEV. BE (FT)
			BOT. PERF. ELEV. (FT)	MAT'L	DIA. Db (IN)	INLET ELEV. BIE (FT)	LENGTH BI (FT)	OUTLET ELEV. BOE (FT)	TOP ELEV. ETE (FT)	TOP WIDTH ETW (FT)		

TRAP NO.	OUTLET BASIN			
	RIPRAP SIZE (R-___)	DEPTH D (FT)	WIDTH OBW (FT)	LENGTH OBL (FT)



## CHAPTER 9 - OUTLET PROTECTION

As a rule, outlet protection has little, if any, sediment removal potential. Therefore, **outlet protection by itself is not an ABACT. However, it should be used in all watersheds to prevent erosion due to concentrated discharges.**

**General** - Discharge velocities from pipe outfalls, outlet channels, or similar structures should not cause erosion in downstream channels. The conditions in the downstream channel should be analyzed to determine if existing conditions will be stable or if a protective lining is necessary. When designing outlet protection for a channel or swale, use the guidance for a pipe having an equivalent cross-sectional area and design discharge to the channel or swale.

When a pipe is flowing full, the anticipated velocity can be calculated from the continuity equation:

$$V = Q/A$$

where  $V$  = Velocity (fps)  
 $Q$  = Design Discharge (cfs)  
 $A$  = Cross-sectional Area of the Pipe (ft<sup>2</sup>)

When a pipe is not flowing full, a different procedure should be used to determine the velocity. Due to the increased friction that occurs along the wetted perimeter, full flow does not represent the greatest flow capacity of a pipe. For circular pipes, peak flow actually occurs at 93% of the total inside diameter. Likewise, the average velocity of a pipe flowing 1/2 full is equal to that for one flowing full. Therefore, the anticipated velocity should be determined either by use of Manning's equation for circular channels, standard design nomographs, or by use of Figure 9.1 — limited to pipes with gradients <0.05 ft/ft.

To use Figure 9.1, the full flow capacity of the pipe should be determined from the following equation.

$$Q_f = \frac{0.464}{n} D^{8/3} S^{1/2}$$

Use the Continuity Equation to determine the full-flow velocity:

$$V_f = \frac{Q_f}{A}$$

Calculate the ratio of partial to full-flow discharge:

$$d/D = \frac{Q_d}{Q_f}$$

where  $d/D$  = Ratio of Part-Full to Full-Flow Discharge  
 $Q_d$  = Design Discharge (cfs)  
 $Q_f$  = Full-Flow Discharge (cfs)  
 $D$  = Diameter (ft)  
 $S$  = Slope of pipe

Using Figure 9.1, find the value for  $d/D$  ratio. Project a vertical line from the  $d/D$  ratio upward to the FLOW curve, then a horizontal line to the VELOCITY curve, and then follow a vertical line downward to determine the velocity ratio.

Multiply the velocity ratio by the velocity calculated from the Continuity Equation to determine the less than full velocity.

EXAMPLE: Calculate the anticipated discharge velocity for a 24" diameter circular concrete pipe with a 0.5% slope and a design discharge of 12.7 cfs.

Full-Flow Discharge

$$Q_f = \frac{0.464}{0.015} (2)^{8/3} (0.005)^{1/2}$$

$$Q_f = 30.93 \times 6.35 \times 0.07 = 13.7 \text{ cfs}$$

Full-Flow Velocity

$$V_f = \frac{13.7 \text{ cfs}}{3.14 \text{ ft}^2} = 4.4 \text{ fps}$$

Ratio of Part-Full to Full-Flow Discharge:

$$d / D = \frac{12.7}{13.7} = .93$$

From Figure 9.1, the Velocity ratio is 1.13

$$V_d = 4.4 \text{ fps} \times 1.13 = 5.0 \text{ fps}$$

The downstream channel lining should be able to withstand a velocity of 5.0 fps.

**For pipes with slopes equal to or greater than 0.05 ft/ft, Manning's equation should be used.**

The velocity is calculated for full flow conditions even though the pipe is typically flowing only partially full. Partial flows will be very close to the full flow velocity for depths of flow between 30 percent and 100 percent of the pipe diameter in steep slope conditions. Manning's equation for full pipe flow is as follows:

$$V = \frac{1.486}{n} \left[ \frac{D}{4} \right]^{\frac{2}{3}} \sqrt{S}$$

where:            V = Velocity in fps  
                      D = Pipe diameter in feet  
                      S = Pipe slope in ft/ft

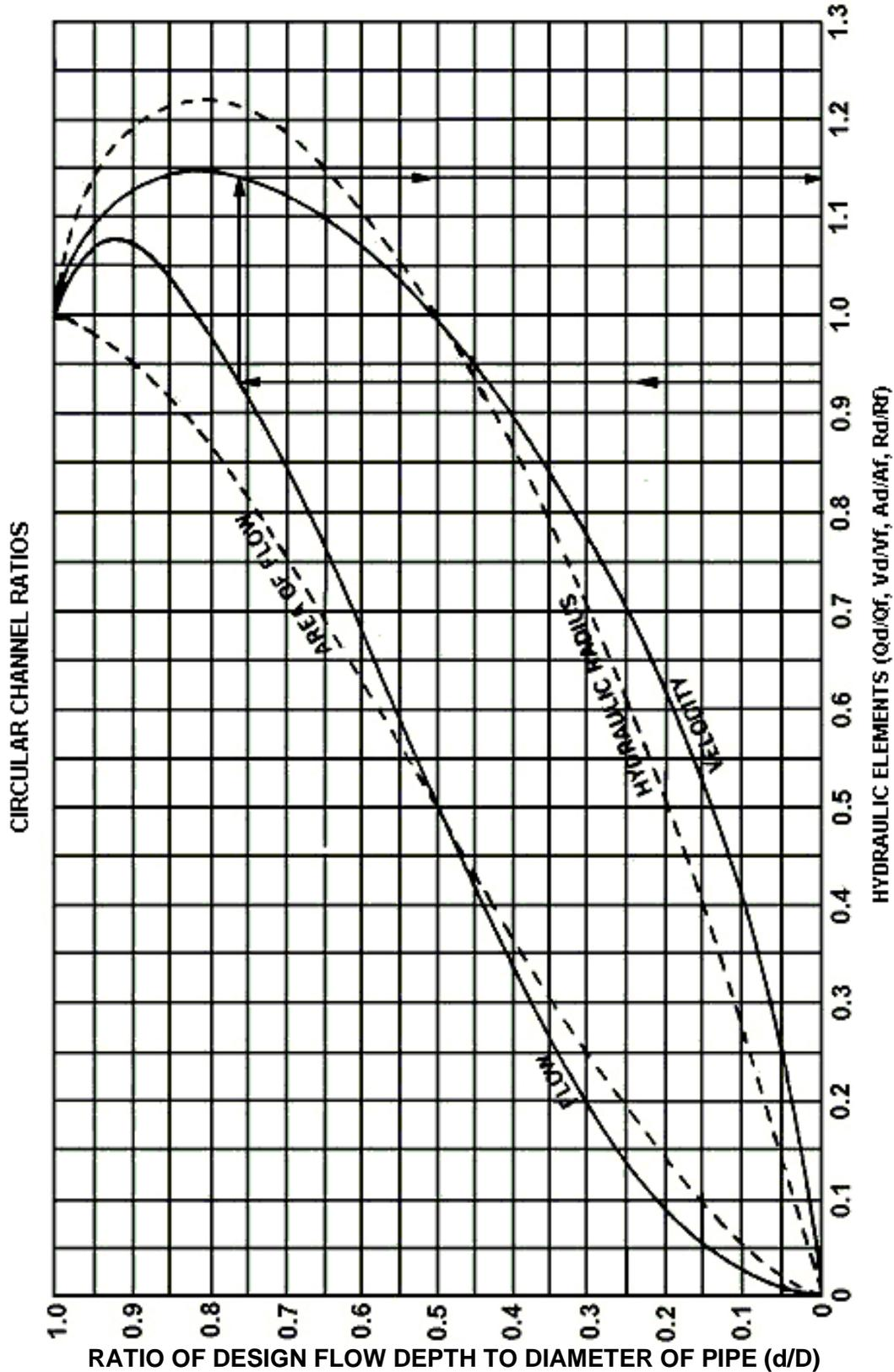
Example: For a 24-inch diameter CMP pipe at a 10% slope.

$$V = \frac{1.486}{.024} \left[ \frac{2}{4} \right]^{\frac{2}{3}} \sqrt{0.10}$$

$$V = 61.9 \times 0.63 \times 0.32 = 12.5 \text{ fps}$$

For pipes with high anticipated velocities (>13.0 FPS), drop structures or other energy reducing structures are recommended to reduce velocity prior to discharge.

**FIGURE 9.1**  
**Velocity Adjustment Nomograph for Less Than Full Pipe Flow**



Adapted from *Design and Construction of Sanitary and Storm Sewers*, p. 87, ASCE, 1969

Do not use this nomograph to determine “equivalent pipe sizes” for discharges ( $Q_d$ ) that do not intersect curves corresponding to proposed pipe sizes on Figures 9.3 and 9.4.

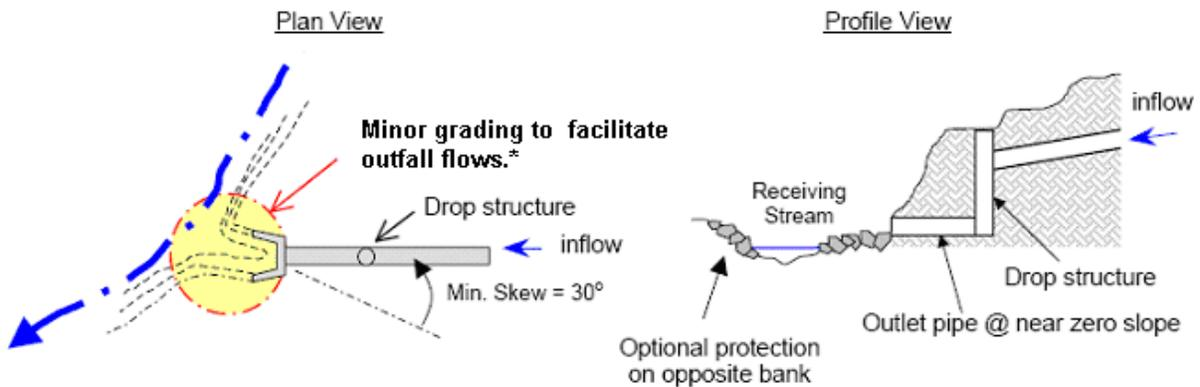
**RIPRAP APRON** - Riprap aprons may be used to prevent scour at pipe or channel outfalls where anticipated discharge velocities do not exceed 17.0 feet per second, there is sufficient room to construct the apron, and where the aprons can be installed on a level grade. In cases where discharge velocities exceed 17.0 fps, a suitable means of velocity reduction (e.g. drop structure) should be used prior to discharging significant flows onto a riprap apron.



PA DEP

Aprons should be oriented so that the discharge enters the receiving channel at less than 90 degrees to the channel flow direction, as shown in Figure 9.2. In no case should the discharge enter the channel at an angle greater than 90 degrees to the channel flow direction.

**FIGURE 9.2  
PROPER OUTFALL ORIENTATION TO RECEIVING STREAM**



**\*Chapter 105 permit(s) required. Provide sediment barrier to protect stream and outfall channels.**

Riprap aprons should be constructed according to the dimensions shown in Standard Construction Detail # 9-1 for outfalls having an endwall, or Standard Construction Detail #9-2 for outfalls with no

endwall. For discharges directly into a downslope channel, use Standard Construction Detail #9-3. They should be constructed at or near zero grade from back to front and side to side. Where aprons are constructed with a gradient back to front, the rock size and/or apron length should be adjusted upwards to compensate. **In no case should riprap aprons be constructed with a back to front gradient exceeding 0.05 ft/ft.**

Determine whether the maximum or minimum tailwater conditions exist at the outfall for the design discharge.

Minimum tailwater exists when the depth of the flow in the receiving watercourse, as calculated by Manning's equation, is less than  $\frac{1}{2}$  the diameter of the discharge pipe, or where no channel or swale exists at the point of discharge. Where this condition exists, use Figure 9.3. If the resulting apron width is wider than the existing channel width and discharge is directly into a downslope channel, as shown in Standard Construction Detail # 9-3, use the channel width as the width of the apron.

Maximum tailwater exists when the depth of flow in the receiving watercourse, as calculated by Manning's equation, is greater than  $\frac{1}{2}$  the diameter of the discharge pipe. Where this condition exists, use figure 9.4. If the resulting apron width is wider than the existing channel width and discharge is directly into a downslope channel, as in Standard Construction Detail # 9-3, use the channel width as the width of the apron.

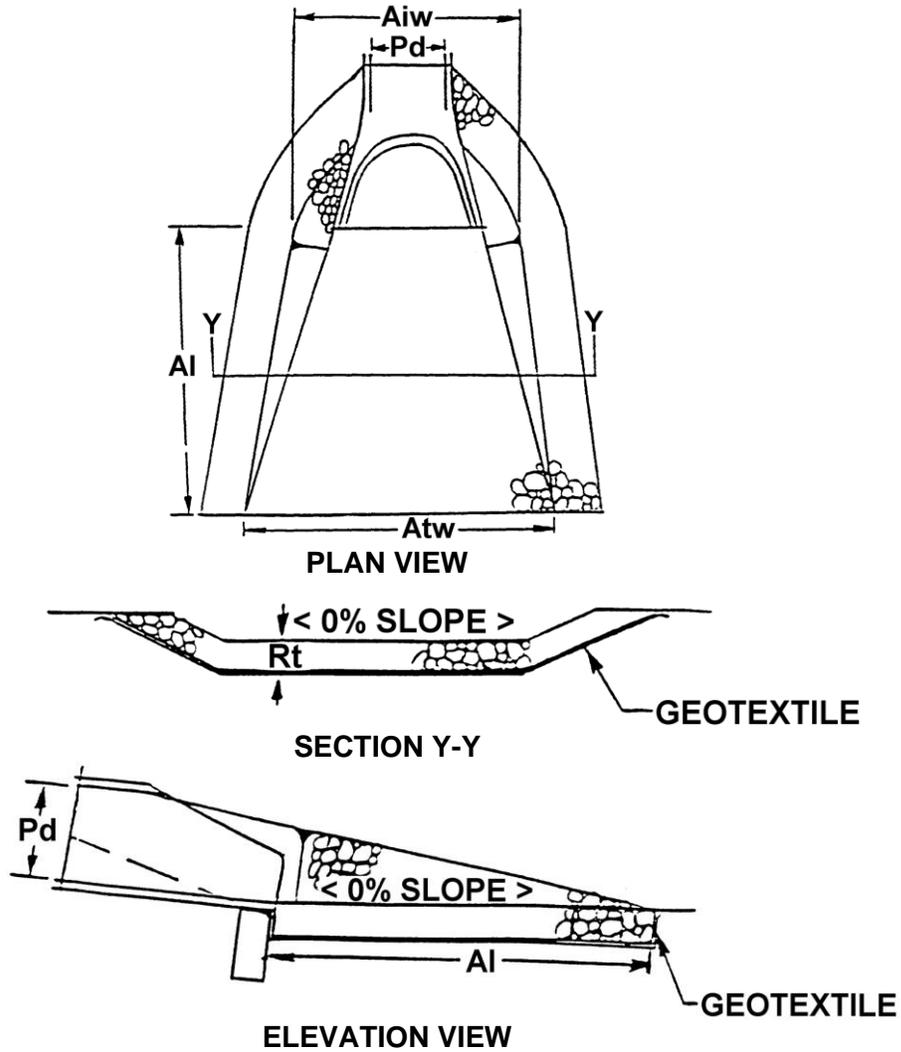
**Note: Figure 9.3 and 9.4 should not be used for designing outlet protection below box culverts.**

If the anticipated discharge velocity exceeds the maximum allowable in Table 6.6 for the riprap size taken from Figure 9.3 or 9.4, the size of the riprap should be increased to a size whose permissible velocity is not exceeded. If the velocity exceeds the maximum permissible for riprap, a suitable method of reducing the velocity prior to discharge onto the rock (e.g. drop structure or dissipater) should be incorporated into the design. Should a design discharge not intersect the curve corresponding to the pipe diameter, use the lowest point on that curve to determine apron dimensions.

Grouting of riprap is not recommended for most installations. Where riprap is grouted, the following applies:

1. Precautions must be taken to prevent uncured concrete from coming in contact with any surface waters.
2. Grout should be placed in a layer with thickness equivalent to the d50 stone size over the entire extent of the apron prior to rock placement.
3. After stone placement, void spaces should be filled with grout.

**STANDARD CONSTRUCTION DETAIL # 9-1**  
**Riprap Apron at Pipe Outlet with Flared End Section or Endwall**



PA DEP

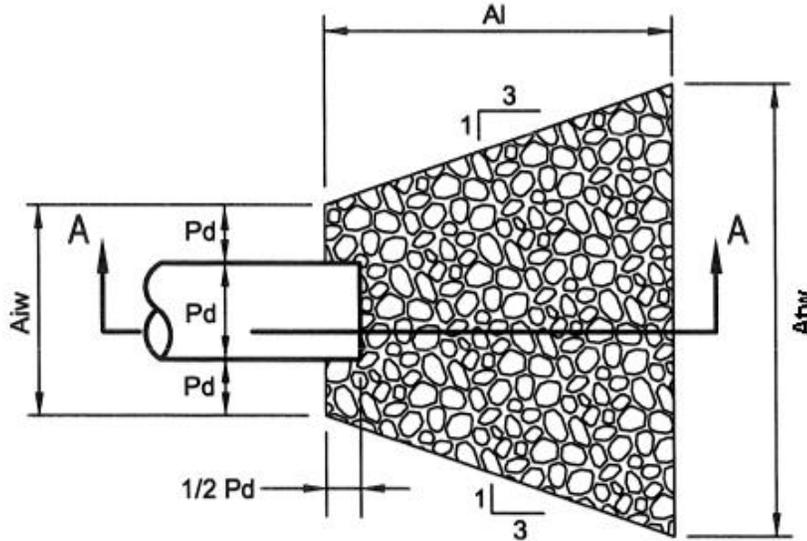
NOTE: This table is intentionally blank and should be filled in by the plan preparer.

OUTLET NO.	PIPE DIA Pd (IN)	RIPRAP		LENGTH Al (FT)	APRON	
		SIZE (R-___)	THICK. Rt (IN)		INITIAL WIDTH Aiw (FT)	TERMINAL WIDTH Atw (FT)

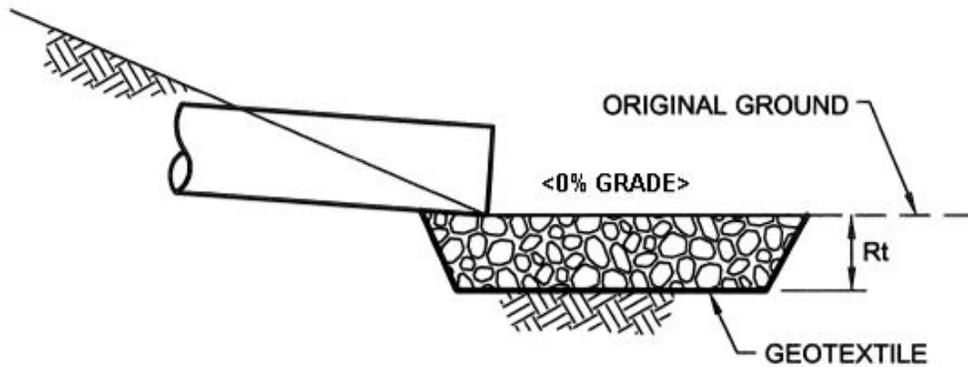
All aprons shall be constructed to the dimensions shown. Terminal widths shall be adjusted as necessary to match receiving channels.

All aprons shall be inspected at least weekly and after each runoff event. Displaced riprap within the apron shall be replaced immediately.

**STANDARD CONSTRUCTION DETAIL # 9-2  
Riprap Apron at Pipe Outlet without Flared Endwall**



PLAN VIEW



SECTION A - A

Adapted from USDOT, FHA HEC-14

NOTE: This table is intentionally blank and should be filled in by the plan preparer.

OUTLET NO.	PIPE DIA Pd (IN)	RIPRAP		APRON		
		SIZE (R-__)	THICK. Rt (IN)	LENGTH Al (FT)	INITIAL WIDTH Aiw (FT)	TERMINAL WIDTH Atw (FT)

All aprons shall be constructed to the dimensions shown. Terminal widths shall be adjusted as necessary to match receiving channels.

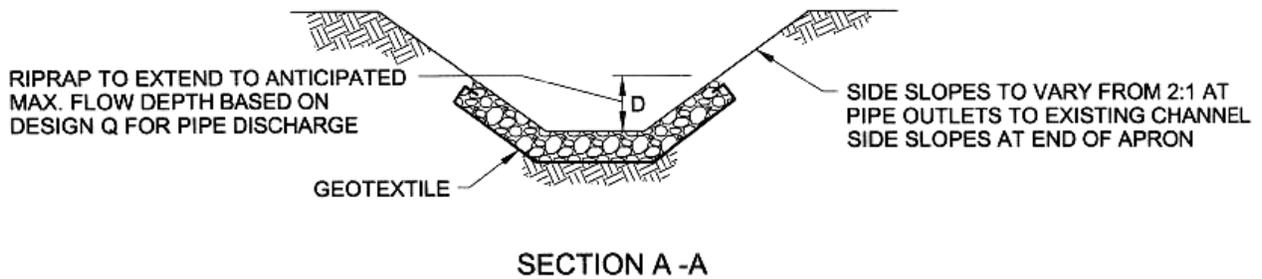
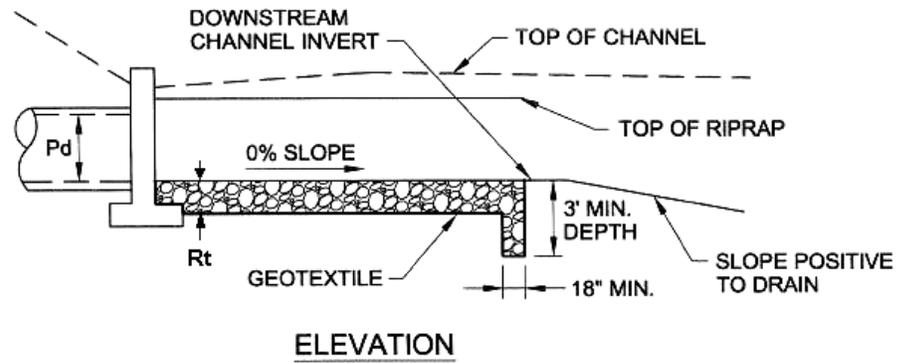
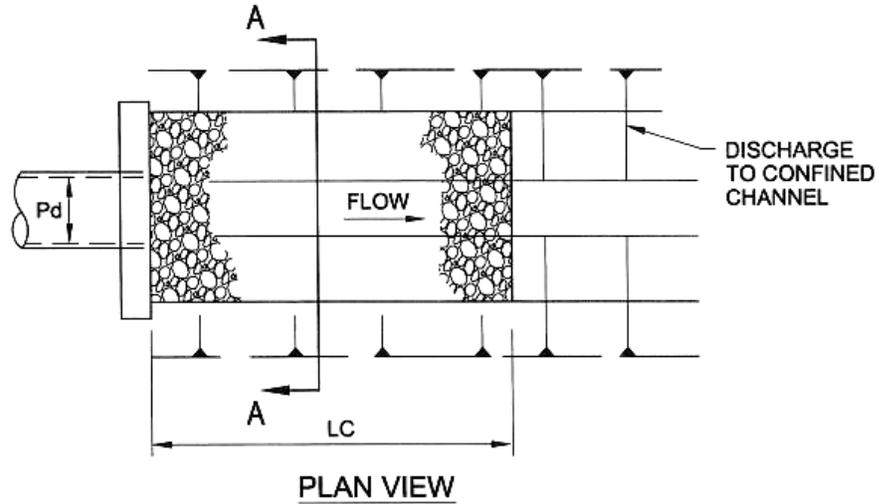
All aprons shall be inspected at least weekly and after each runoff event. Displaced riprap within the apron shall be replaced immediately.

Extend riprap on back side of apron to at least ½ depth of pipe on both sides to prevent scour around the pipe.





**STANDARD CONSTRUCTION DETAIL # 9-3  
Riprap Apron at Pipe Outlet to an Existing Channel**



Adapted from USDA NRCS

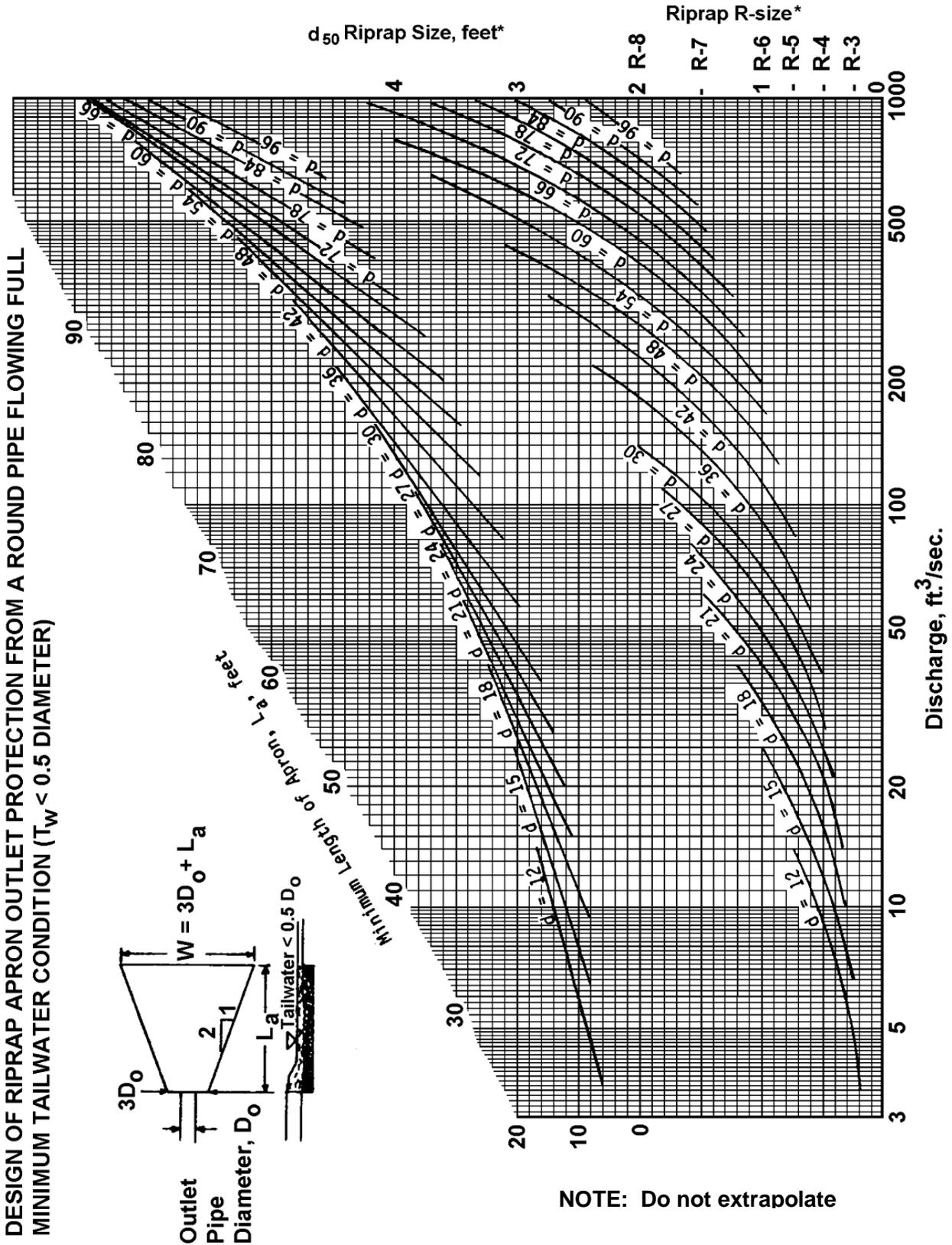
NOTE: This table is intentionally blank and should be filled in by the plan preparer.

OUTLET NO.	PIPE DIA Pd (IN)	RIPRAP		LENGTH LC (FT)	INITIAL BOTTOM WIDTH (at Endwall)(FT)	APRON				
		SIZE (R-__)	THICK. Rt (IN)			END WIDTH (FT)	INITIAL TOP WIDTH (at Endwall) (FT)	END TOP WIDTH (FT)	SIDE SLOPES H:V	

All aprons shall be constructed to the dimensions shown. Terminal widths shall be adjusted as necessary to match receiving channels.

**All aprons shall be inspected at least weekly and after each runoff event. Displaced riprap within the apron shall be replaced immediately.**

**FIGURE 9.3**  
**Riprap Apron Design, Minimum Tailwater Condition**

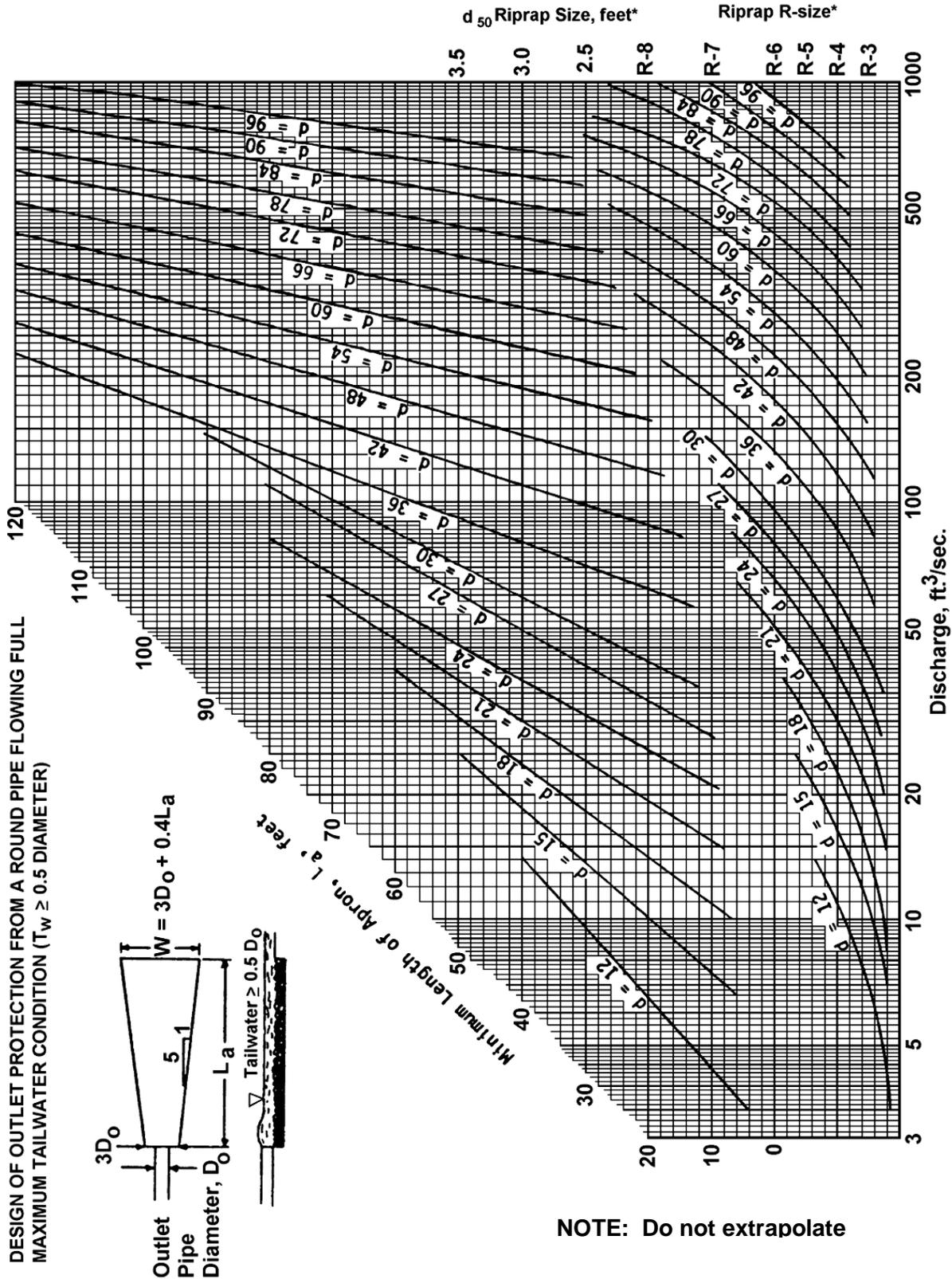


\* For discharge velocities exceeding Maximum Allowable for Riprap indicated, increase  $d_{50}$  stone size and/or provide velocity reduction device.

Adapted from USDA - NRCS

Not to be used for Box Culverts

**FIGURE 9.4**  
**Riprap Apron Design, Maximum Tailwater Condition**



Adapted from USDA - NRCS

Not to be used for Box Culverts

Determine whether maximum or minimum tailwater conditions exist at the outfall for the design discharge.

Minimum tailwater exists when the depth of flow in the receiving watercourse, as calculated by Manning's equation, is less than  $\frac{1}{2}$  the diameter of the discharge pipe, or where no channel or swale exists at the point of discharge. Where this condition exists, use Figure 9.3. If the resulting apron width is wider than the existing channel width and discharge is directly into a downslope channel, as in Standard Construction Detail #9-3, use the channel width as the width of the apron.

Maximum tailwater exists when the depth of flow in the receiving watercourse, as calculated by Manning's equation, is greater than  $\frac{1}{2}$  the diameter of the discharge pipe. Where this condition exists, use Figure 9.4. If the resulting apron width is wider than the existing channel width and discharge is directly into a downslope channel, as in Standard Construction Detail #9-3, use the channel width as the width of the apron.

For less than full-pipe flow conditions, calculate anticipated velocity as described at the beginning of this chapter and adjust riprap size where necessary to comply with Table 6.6. Locate the design discharge along the bottom of Figure 9.3 or 9.4. Follow a vertical line to the point where it intersects the first curve corresponding to the diameter of the discharge pipe. From that point follow a horizontal line to the right to determine the minimum R-size of the riprap. **Do not extrapolate the curve lines.** Where flows fall below the curve for a specific size of pipe, use the minimum rock size and apron dimensions indicated at the lower ends of the curves for the proposed pipe size.

Check Table 6.6 to make sure that the anticipated discharge velocity does not exceed the maximum permissible velocity for the size of riprap obtained in this step. If the anticipated discharge velocity exceeds the maximum permissible velocity, increase the size of the riprap to a size whose permissible velocity is not exceeded.

Follow the same vertical line mentioned above to the point where it intersects the second curve corresponding to the diameter of the discharge pipe. From that point, follow a horizontal line to the left and read the minimum length of the apron ( $L_a$ ) in feet.

For minimum tailwater conditions, the apron width ( $W$ ) may be calculated by the formula:

$$W = 3D_o + L_a$$

where  $D_o$  = Outlet pipe diameter  
 $L_a$  = Length of the apron

For maximum tailwater conditions, the apron width ( $W$ ) may be calculated by the formula:

$$W = 3D_o + 0.4 L_a$$

Where the apron design width ( $W$ ) exceeds the downstream watercourse bottom width and the apron is directly in line with the channel, the maximum width of the apron should be the channel width.

Grouting of riprap is not recommended for most installations. Where riprap is grouted, the following applies:

1. Precautions must be taken to prevent uncured concrete from coming into contact with any surface waters.
2. Grout should be placed in a layer with thickness equivalent to the d50 stone size over the entire extent of the apron prior to rock placement.
3. After stone placement, void spaces should be filled with grout.

**FLOW TRANSITION MAT** - Transition mats may be used to prevent scour below pipe outfalls where the anticipated flow depth of the tailwater is less than or equal to  $1/3$  the pipe diameter (D). The mats should be placed at the pipe outlet, preferably in contact with the pipe and centered laterally with the pipe (see Figure 9.5).

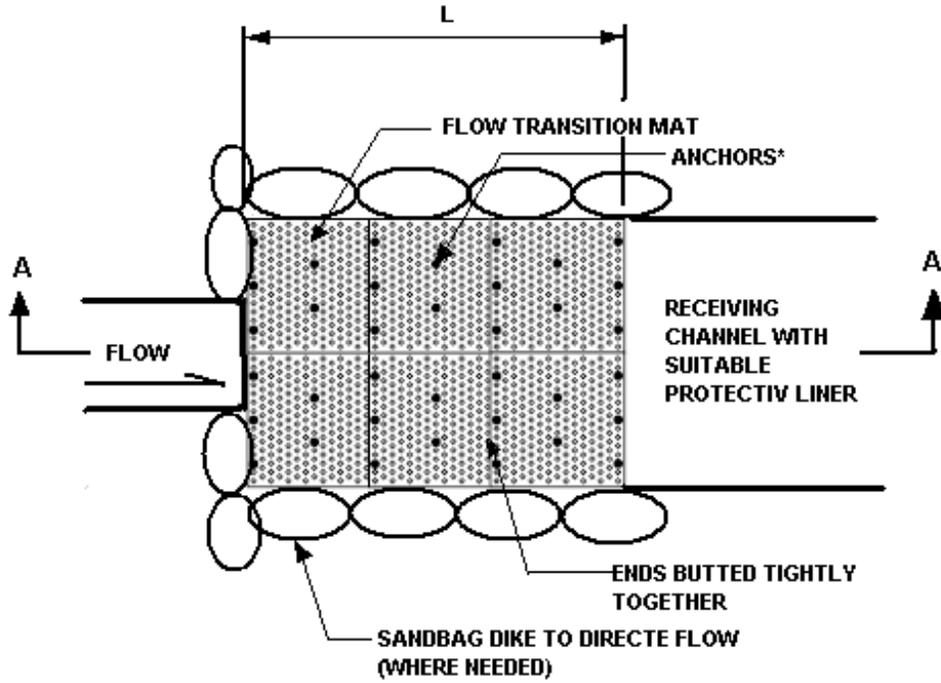


ScourStop

The surface on which the mats are to be placed should be smooth and uniform. If a thick uniform sod is not present, a Turf Reinforcement Mat (TRM) or High Performance TRM (HPTRM) should be installed as an underlayment for the mats. The TRM (or HPTRM) should be capable of withstanding a velocity of at least 5.5 fps in the unvegetated condition.

Since transition mats do not dissipate energy, the receiving channel should be capable of handling the design discharge without accelerated erosion. Wherever this is not the case, additional energy dissipation should be provided. Transition mats may also be used for other applications (e.g. streambank stabilization) if manufacturer's recommendations are followed.

**FIGURE 9.5  
Typical Transition Mat Installation**

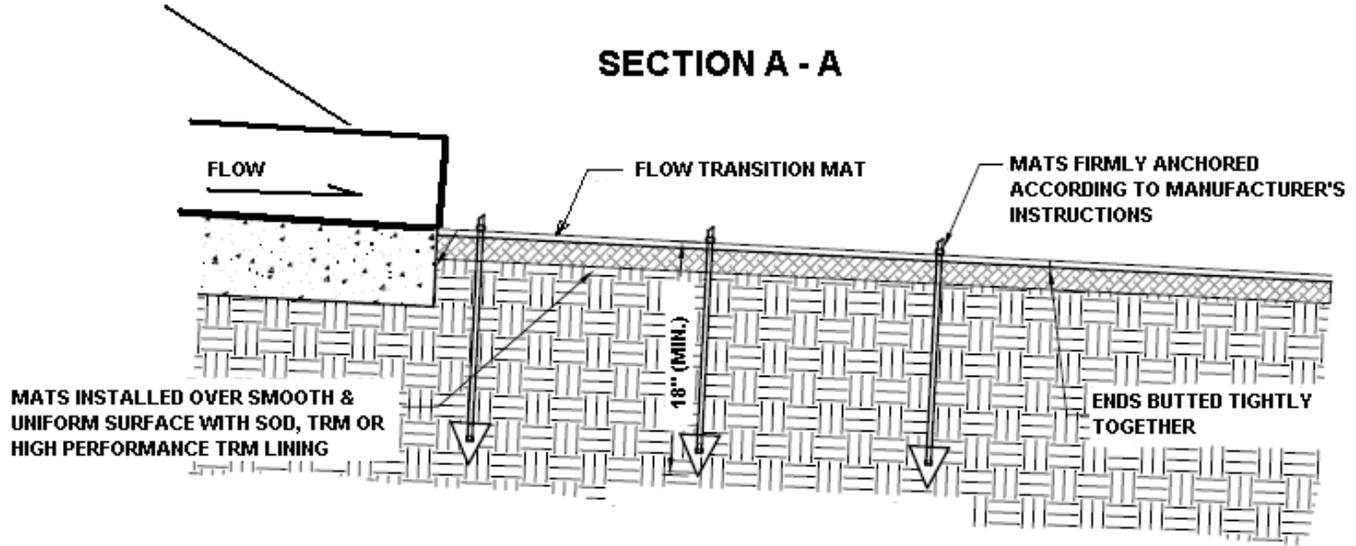


\*INSTALLED ACCORDING TO MANUFACTURER'S RECOMMENDATIONS

NOTE: ADD AN ADDITIONAL ROW OF MATS ALONG EACH SIDE WHERE NEEDED FOR LARGER FLOWS

**PLAN VIEW**

**SECTION A - A**



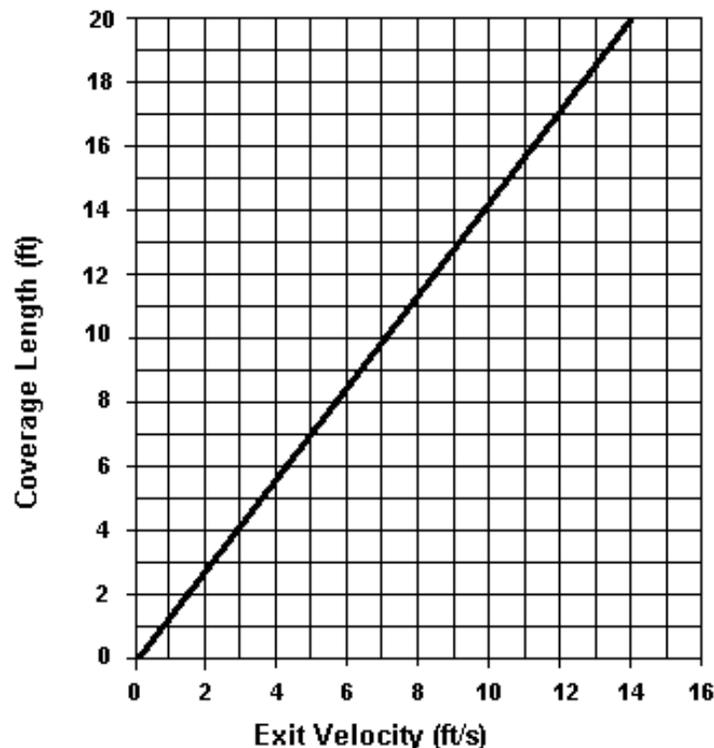
Adapted from ScourStop

**NOTE: For permanent installations, replace sandbags with concrete or rock.**

## Design Considerations

- Flow transition mats should be installed on a smooth, level, side-to-side surface to avoid water concentration. Where necessary, the surface should be graded to remove any unevenness. Transition mats should not be used where a change in slope greater than 25% will be encountered.
- Wherever a thick sod is not present, a TRM underlayment should be installed. For slopes greater than 10H:1V, an HPTRM should be used. The TRMs should be capable of withstanding velocities of at least 5.5 fps.
- The finish elevation of the top of the mats should be at or slightly below — 3” maximum — the pipe outlet.
- The width of the mats should be equal to the downstream channel. Where discharging directly into a surface water, the design should allow for as much expansion of flow width as possible to reduce velocities and promote infiltration.
- The downstream slope should be as flat as possible to avoid increasing the velocity.
- The length of the mat should be determined from Figure 9.6. A double layer of mats, with the open area of the second layer offset from those of the first layer, should be used where any of the following conditions apply:
  - The installation is located on erodible soils
  - The installation is located in a special protection watershed
  - The anticipated discharge velocity exceeds 7 fps
  - The slope on which the mat is placed is 10H:1V or steeper.
- Anchor transition mats to achieve consistent contact with the underlying surface and prevent seepage underneath the mat.
- Locate the outlet and transition mat where adequate sunlight is available to promote healthy vegetation.
- Failure of a transition mat has occurred when a rill forms under the mat. Wherever that occurs, the mat should be removed, the rill graded, and a higher form of protection provided.

**FIGURE 9.6**  
**Minimum Coverage Length vs. Exit Velocity for Flow Transition Mat**



Adapted from Robeson, Colorado State University



**STILLING BASIN (Plunge Pool)** - Stilling basins may be used at pipe outfalls where the discharge is at or near horizontal, and sufficient room exists to construct the basin between the pipe and the receiving watercourse. The size and shape of stilling basins is based upon the anticipated scour hole below a pipe outfall due to a design discharge. Experience has shown that the size and amount of the riprap required for a stilling basin are often less than would be required for a riprap apron.



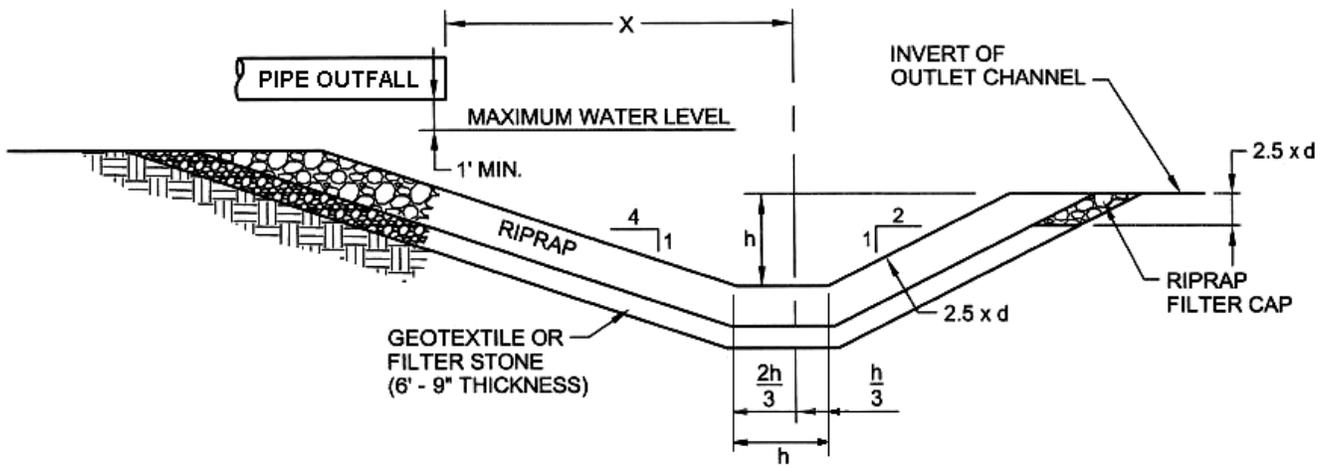
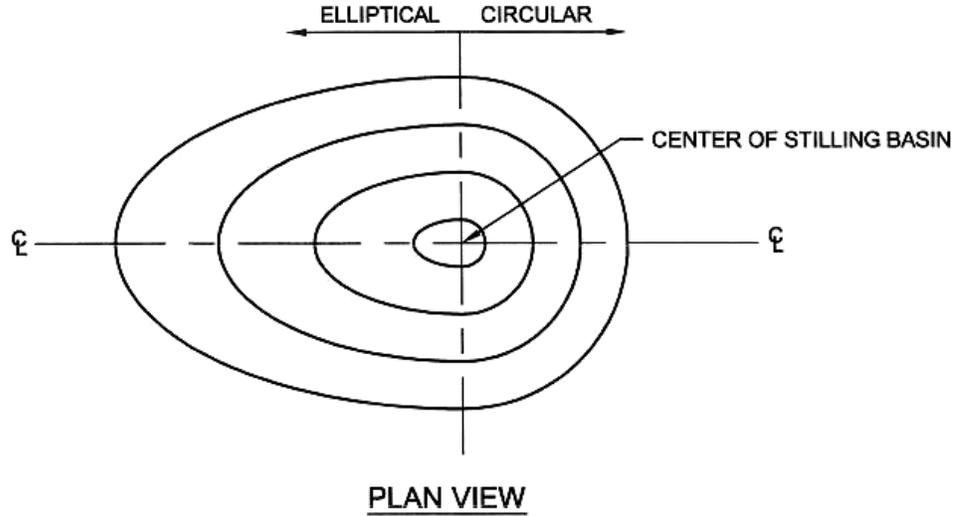
Vernon County Land and Water Conservation

Stilling basins should be designed and constructed according to the details shown in Standard Construction Detail # 9-4. Geotextile may be substituted for the filter stone underlayment.

The minimum vertical distance from the bottom of the pipe to the maximum water surface elevation is 12 inches.

# STANDARD CONSTRUCTION DETAIL # 9-4

## Stilling Basin



### SECTION ALONG CENTERLINE

Adapted from USDOT, FHWA HEC 14

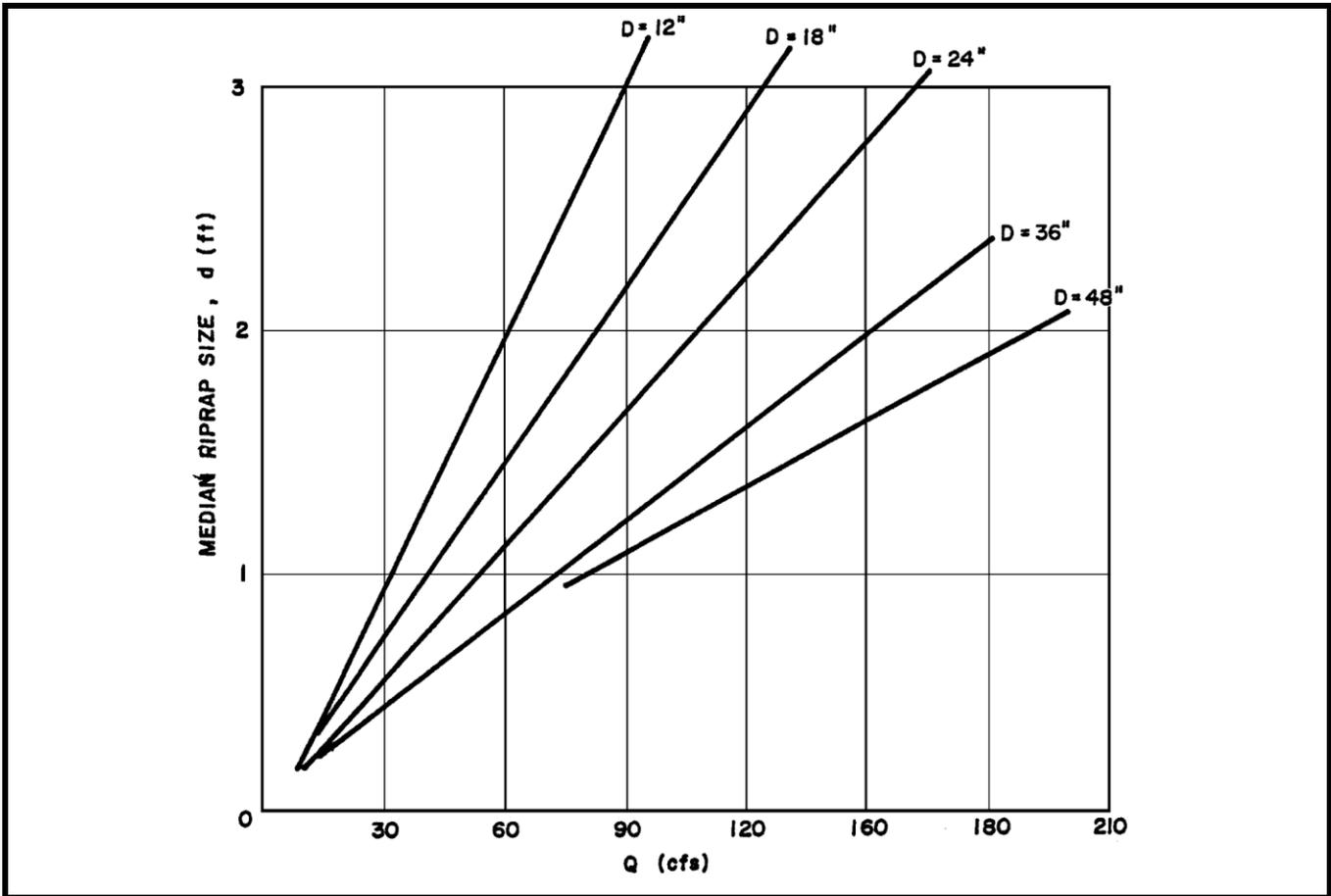
NOTE: This table is intentionally blank and should be filled in by the plan preparer.

OUTLET NO.	X (ft)	h (ft)	Riprap Size (R <sub>50</sub> )	d <sub>50</sub> Stone Size d (in)

**Riprap thickness shall be 1.5 times the maximum stone size.**

Determine the d<sub>50</sub> stone size (d) for the stilling basin from Figure 9.7 using the design discharge and the pipe diameter.

**FIGURE 9.7**  
**d<sub>50</sub> Stone Size for Stilling Basins**



Adapted from USDOT, FHWA HEC 14

Calculate the required basin depth (h) by the formula:

$$h = D^{1/3} \left[ 0.148 \frac{Q}{Dd^{1/2}} - 1.82 (d) \right]^{2/3}$$

- where: h = Basin depth (ft)  
 D = Inside diameter of the pipe (ft)  
 d = d<sub>50</sub> stone size of the riprap (ft)  
 Q = Design discharge (cfs)

Calculate the distance (X) in feet from the end of the discharge pipe to the "center" of the basin by using the following formula:  $X = (V^2/2g)^{0.5} [(1+m/p)^{0.5} + 1+m/2p] p^{0.5}$

- where: v = Discharge velocity (fps)  
 g = Acceleration due to gravity (32.2 ft/sec<sup>2</sup>)  
 m = Depth of water (ft) in the basin during maximum pipe discharge (i.e. h + channel flow depth)  
 p = Vertical distance (ft) from inside crown of the pipe to the maximum water surface

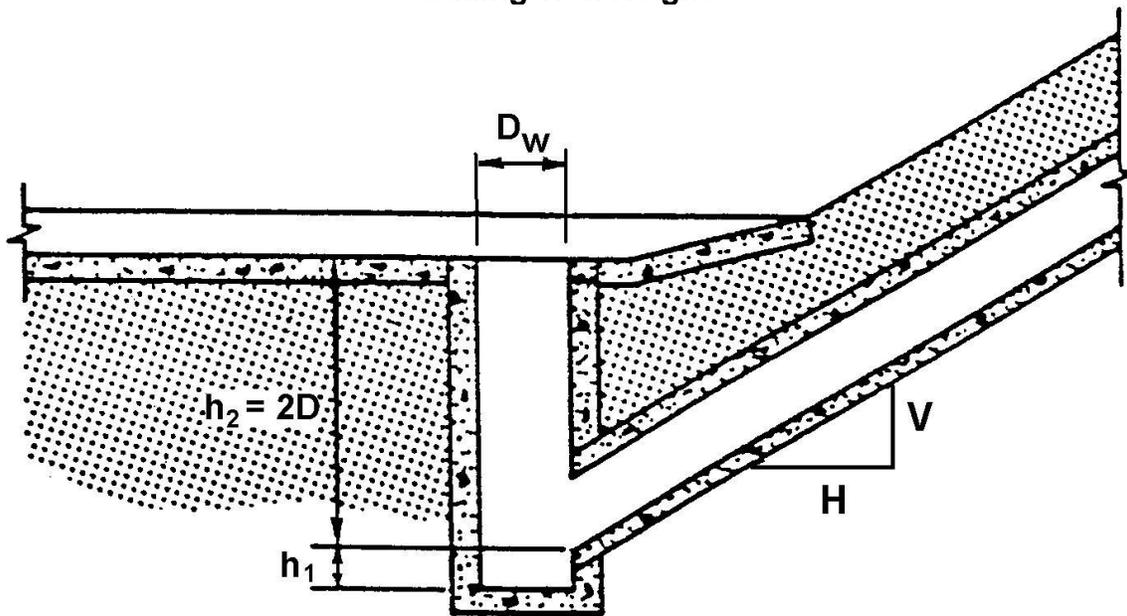
**STILLING WELL** - Stilling wells may be used where little floating or rolling debris is expected. Since tailwater increases the efficiency of a stilling well, whenever possible, it should be located in a sump or depressed area. Riprap or other scour protection should be provided for a distance of at least three times the well diameter downstream.



Source Unknown

Stilling wells should be constructed according to the details shown in Figure 9.8.

**FIGURE 9.8**  
**Stilling Well Height**



USDOT, FHWA HEC 14

Using the pipe diameter ( $D$ ) in feet and design discharge ( $Q$ ) in cfs, determine the well diameter ( $D_w$ ) from Figure 9.9.

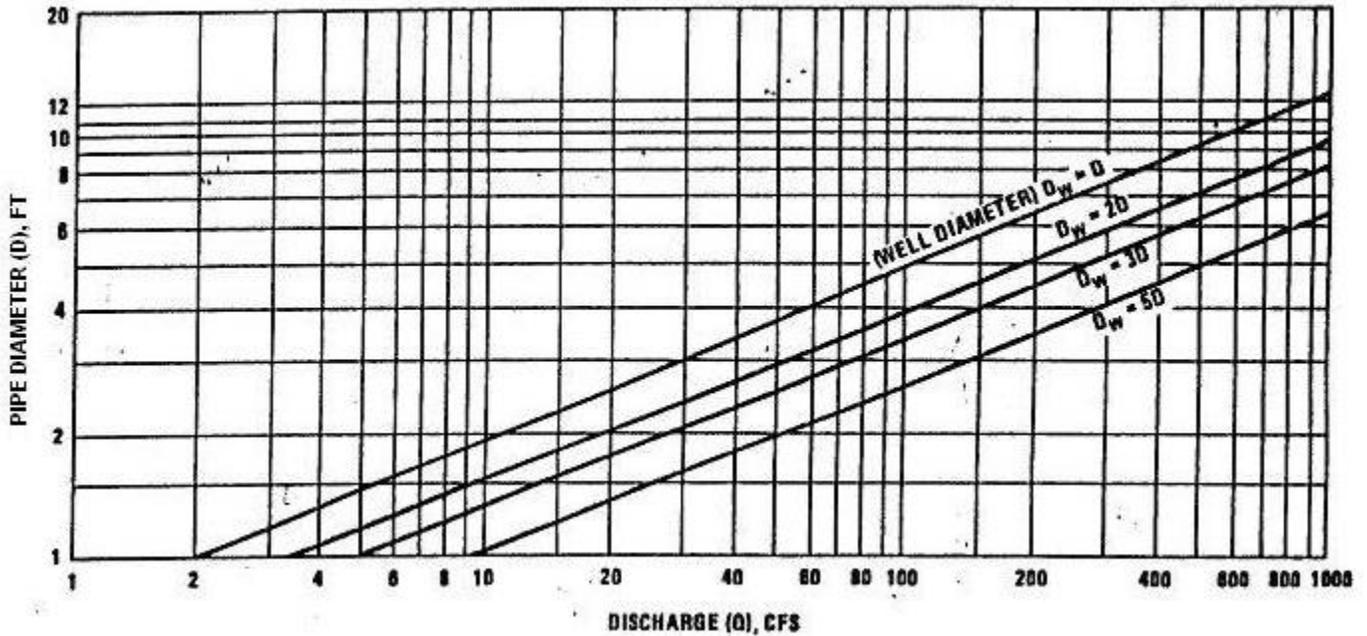
Using the pipe slope (V:H) determine  $h_1/D_w$  from Figure 9.10.

Calculate the depth of well below invert ( $h_1$ ) in feet by multiplying  $h_1/D_w$  by the diameter of the well ( $D_w$ ).

Minimum depth of the well ( $h_2$ ) above the pipe invert is  $2(D)$ . Note: Increasing this depth will increase the efficiency of the well.

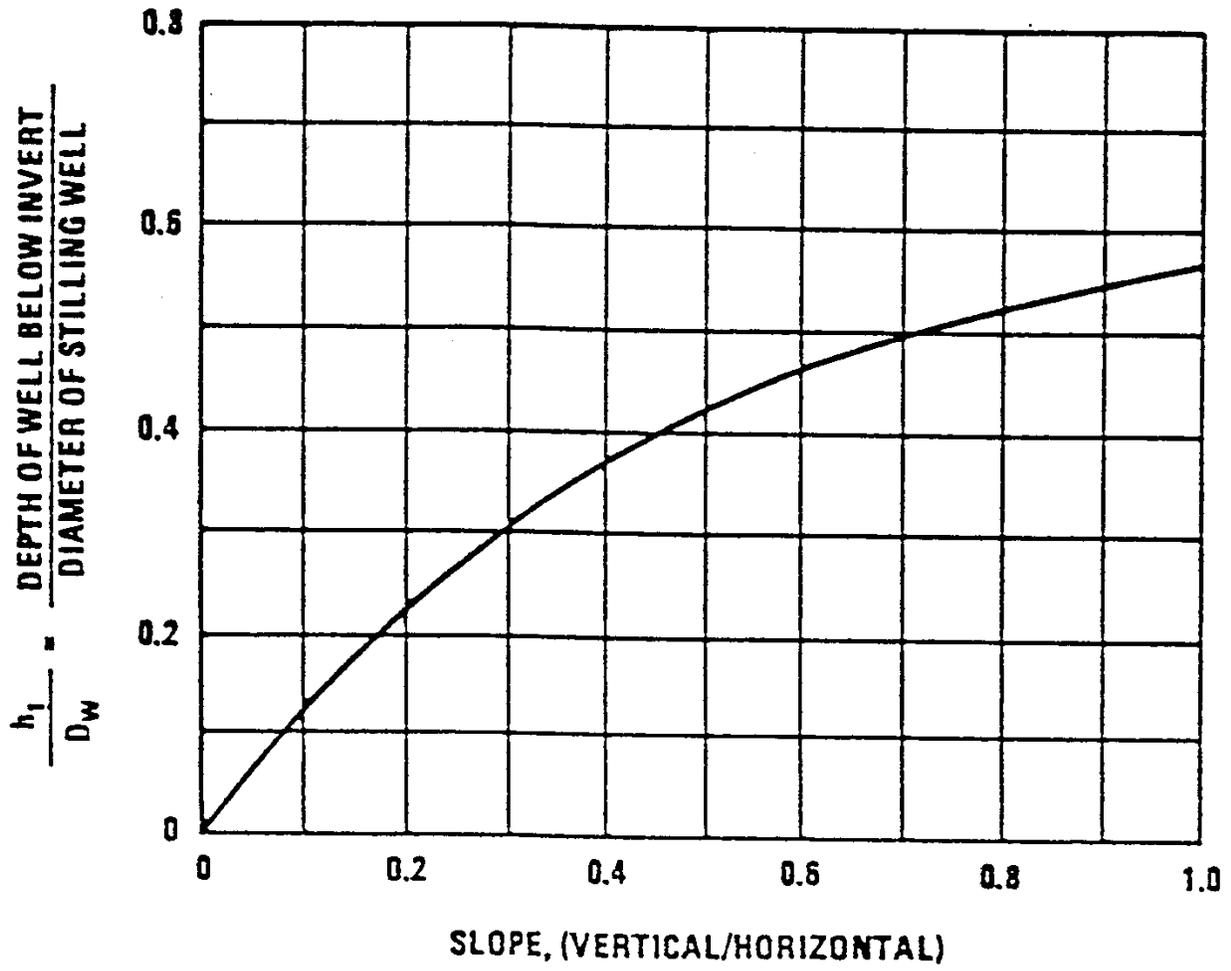
Total depth of the well ( $h_w$ ) =  $h_1 + h_2$ .

**FIGURE 9.9**  
**Stilling Well Diameter**



USDOT, FHWA HEC 14

FIGURE 9.10  
Depth of Well Below Invert



USDOT, FHWA HEC 14

## ENERGY DISSIPATER

Energy dissipaters are often used to reduce outlet velocity from pipe outfalls and box culverts where anticipated velocities exceed the maximum permissible for other types of outlet protection. Design procedures for two typical energy dissipaters are provided in Appendix F. Many other types of dissipaters may be approved as long as supporting calculations are provided that show anticipated velocities have been reduced to acceptable levels and details showing all critical dimensions are provided on the plan drawings. Wherever dissipaters are proposed, they should be in place and functional prior to directing any proposed discharge to that point.

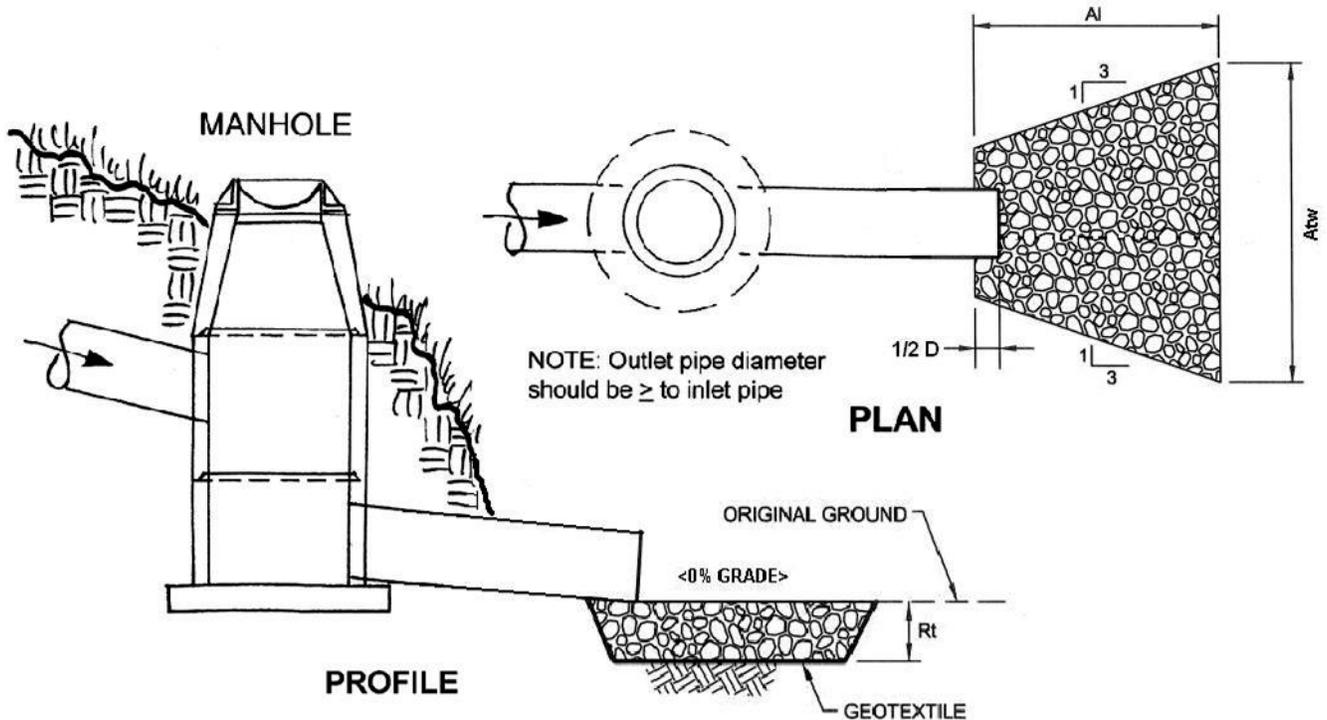


PA DEP

## DROP STRUCTURE

In many cases, significant energy reduction can be accomplished by using drop structures within a piped outfall system (Figure 9.11). The resulting velocities at the discharge point are often within those allowable for typical apron protection. Consideration should be given to incorporating drop structures wherever anticipated velocities exceed 13.0 fps. They may also be desirable for lower velocities to reduce the size of rock in an apron or its overall dimensions. To avoid potential problems with backup of water within the manhole, the depth of the manhole should be at least 2 times the inflow pipe diameter. The outlet pipe diameter should be larger than the inflow unless hydraulic calculations show that a pipe of equal diameter is sufficient to convey the design discharge without backup.

**FIGURE 9.11**  
**Typical Drop Structure**



Adapted from Westmoreland Conservation District



## EARTHEN LEVEL SPREADER

**LOCATION** - Earthen level spreaders are normally used where diversion ditches or dikes outlet onto areas of established vegetation — grass, typically not brush or forested. They are **not** to be used below sediment traps, sediment basins, or stormwater pipes.

Earthen level spreaders may be used for drainage areas less than or equal to 1 acre where sediment-free stormwater runoff can be released in sheet flow down a stabilized slope without causing erosion. Where the downstream slope is stabilized with grass, a minimum uniform cover of 90% is required. Wooded areas, with little or no grass cover, are not considered stabilized areas for this purpose. Earthen level spreaders should only be used where there will be no construction traffic over the level spreader.

To avoid reconcentrating flow downstream of the spreader, the maximum distance from the earthen level spreader to an existing or constructed defined drainage course is 100 feet with a 6% maximum slope and where very uniform and very stable site conditions exist. Greater distances may be considered on a case-by-case basis for very mild slopes and heavily vegetated areas but should not normally exceed 150 feet.

Earthen level spreaders should be constructed on soil, not on fill.

**MAXIMUM DRAINAGE AREA** - Maximum drainage area to an earthen level spreader should not exceed 1 acre.

**MAXIMUM DISCHARGE and MINIMUM LENGTH** - The maximum discharge for earthen level spreaders should be 1 cfs per foot of length based on the peak rate of flow from a ten-year frequency rainfall event. An acceptable simplified method to determine the length ( $L_{min}$ ) is that  $L_{min}$  is equal to five feet per acre of drainage area.

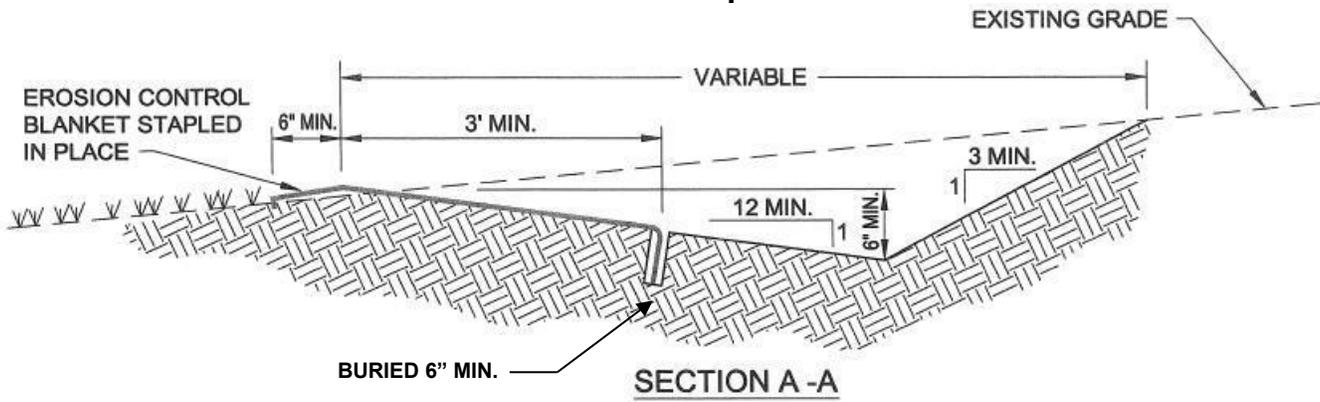
**DESIGN** - The grade of the last 20 feet of the diversion channel that feeds the earthen level spreader should create a smooth transition from the channel grade to the earthen level spreader and, where possible, should be less than or equal to 1 percent. Construct earthen level spreaders on zero percent grades to insure uniform spreading of sediment-free runoff. Minimum width of earthen level spreaders should be 6 feet. A transition section should be constructed between the diversion channel and the earthen level spreader if the widths are different.

Protect the lip of an earthen level spreader with an erosion-resistant material, such as a reinforced erosion control blanket or TRM, to prevent erosion and enable vegetation to become established. For a permanent installation, a rigid lip of non-erodible material, such as pressure-treated timbers or concrete curbing, should be used. A smooth transition should be provided between the level spreader and the native ground downslope.

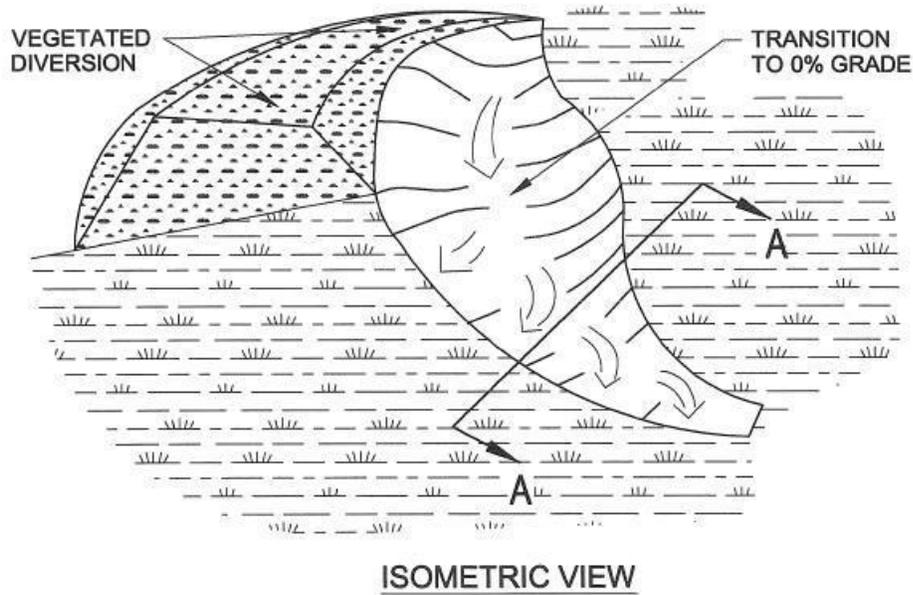
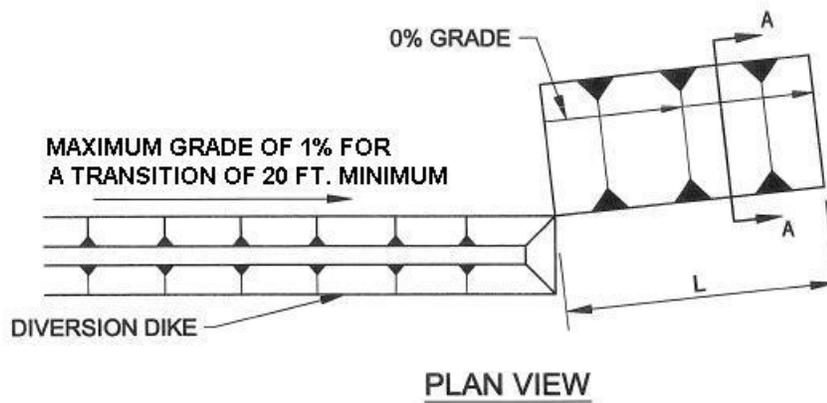
For a vegetated lip, the erosion-control matting should be a minimum of 4 feet wide and extend 6 inches over the level lip. The upstream edge should be buried at least six inches deep in a vertical trench. The downstream edge should be securely held in place with closely spaced, heavy-duty staples, at least 12 inches long. A rigid level lip should be entrenched at least 2 inches below the ground surface and securely anchored to prevent displacement. Immediately after the earthen level spreader is constructed, the entire area of the spreader should be appropriately seeded and mulched.

Typical details of earthen level spreaders are shown on Standard Construction Detail # 9-5.

## STANDARD CONSTRUCTION DETAIL # 9-5 Earthen Level Spreader



Adapted from North Carolina DENR



Adapted from EPA-625/3-76-006

## STRUCTURAL LEVEL SPREADER

**LOCATION** - Structural level spreaders are usually individually designed to accommodate specific site conditions. These types of spreaders may be used below sediment traps, sediment basins, or stormwater pipes where no other means is available to discharge into a surface water.

Structural level spreaders are often desirable where basins discharge to wetlands, to encourage sheet flow rather than channel flow to the wetlands. Other applications include sites where groundwater recharge is the objective. Because each site will be different, design criteria need to be flexible. However, the plan preparer should use sound engineering judgment, and provide documentation for the design criteria selected.

Structural level spreaders should be constructed according to the standards provided in Appendix G or approved alternative.

## CHAPTER 10 - LOW HAZARD INDIVIDUAL LOT E&S PLAN



Low hazard sites are those with limited disturbance (< 1 acre), slopes of 5% or less, and at a distance of 100' or more from surface water.

Chapter 102 requires a written E&S plan for all earth disturbances of 5,000 square feet or more as well as any earth disturbances (of any size) in HQ or EV watersheds. For a low hazard individual lot this plan must be developed before the start of construction and must be available on site at all times during construction. Local municipalities may require the E&S plan to be submitted to them or the local conservation district for review and approval prior to start of construction or issuance of building permits. Therefore, the appropriate

agency should be contacted before the plan is developed.

York County Conservation District

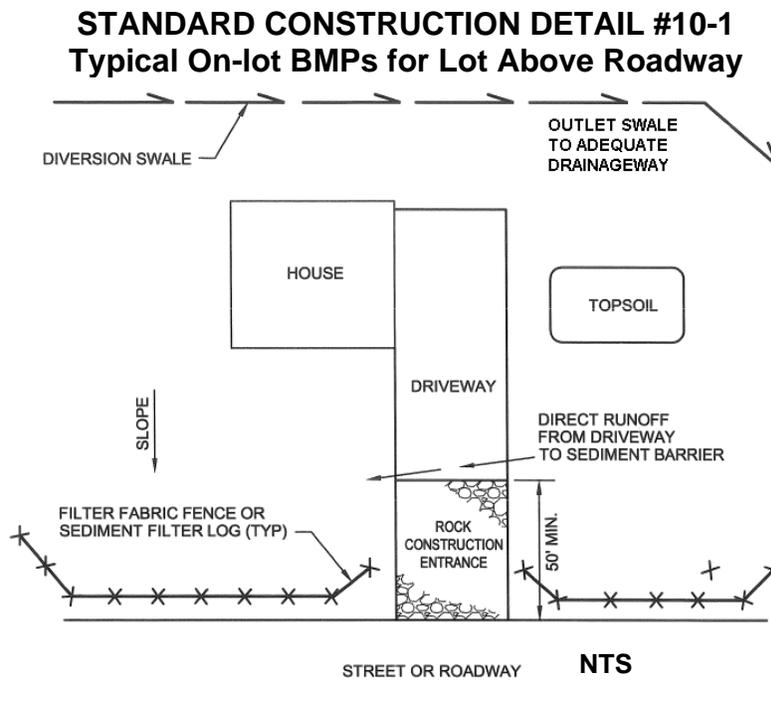
General steps to be taken in developing a plan for an individual low hazard site include:

1. Prepare a sketch plan of the site and indicate general land slopes, limits of the proposed project and existing features such as roads, property boundaries and streams. Select appropriate erosion control BMPs such as compost socks, fiber logs, or silt fence and a stabilized stone construction entrance and show their location on the sketch plan of the site. The compost socks, fiber logs, silt fence, and/or straw bale barriers should be located to filter the stormwater runoff from the disturbed areas before it leaves the site and enters a surface water (e.g. storm sewer). A stabilized construction entrance is usually placed at the location where a driveway will be installed and when properly maintained, minimizes the tracking of mud from the site by construction vehicles. It becomes the base for a permanent driveway to be installed near the completion of construction. A note on the sketch plan should indicate that the various BMPs are to be installed as the first step in project construction. Details for installation of the BMPs are found in the Standard E&S Worksheets and Standard Details section of this manual. Those details should be included on the E&S plan drawings.
2. Hold site grading to the minimum necessary to allow the construction of desired improvements. Construction equipment should be restricted from proposed PCSM infiltration BMP locations (e.g. rain gardens, dry wells, etc.). Access roads should avoid gradients in excess of 10%. Buildings should be located so there is positive drainage away from them. Any topsoil from areas where cuts or fills occur should be stockpiled for redistribution after grading to help establish vegetation.
3. Save existing vegetation to the maximum extent possible, especially trees because of their ability to reduce or prevent erosion. Protect trees and shrubs from damage during earthmoving operations (See Appendix I).
4. Minimize the size and time of exposure for areas to be disturbed. The plan should call for restabilizing disturbed areas by seeding, sodding, or paving as soon as possible. Chapter 102 requires disturbed areas, regardless of size, within HQ or EV watersheds to be stabilized immediately upon reaching final grade.
5. Upslope runoff should be diverted around work areas wherever possible. If diversion is not practical, the runoff should be conveyed through the area of disturbance in such a way that it is protected from sediment pollution.

The E&S plan should include such information as the name, address, and phone number of the person(s) responsible for the project. A brief description of the project including the estimated time frame for its installation should also be included. If this information cannot be provided on the sketch plan of the site, a supplemental sheet with this information should be attached. Published USGS topographic maps should be consulted to determine the name of the nearest stream receiving runoff from the site. If the stream is in a special protection watershed, nondischarge or ABACT BMPs must be used. The NRCS website should be consulted to determine what soil use limitations can be expected on the site. A means to deal with those limitations should be included in the E&S plan. USGS maps, lists of special protection watersheds, and other useful information are available at the local conservation district office. The conservation districts can also provide valuable assistance in E&S plan development. The BMPs used to control runoff from disturbed areas on a single residential housing lot during house construction are often referred to as “on-lot Controls.” Depending on the size of the lot and the amount of disturbance, they may range from sediment barriers to channels and traps. **On-lot controls may not be used instead of perimeter controls such as sediment basins or sediment traps** where such facilities are appropriate, such as housing developments, industrial parks, etc. However, on-lot controls can increase the effectiveness of perimeter controls by reducing the sediment load conveyed to them. They can also reduce the need for street cleaning, flushing of storm sewer lines, and repairs to adjacent lots damaged by uncontrolled runoff. On-lot BMPs are typically not considered as ABACT for permitted housing projects or industrial parks. They may, however, be used in conjunction with other BMPs that are considered ABACT, as described in Chapter 17. Where on-lot controls are proposed as part of the overall E&S plan for a multi-unit development, the appropriate typical details should be placed on the plan drawings. Where this is done, it is not necessary to show on-lot controls for each individual lot on the plan map(s).

## TYPICAL CONFIGURATIONS

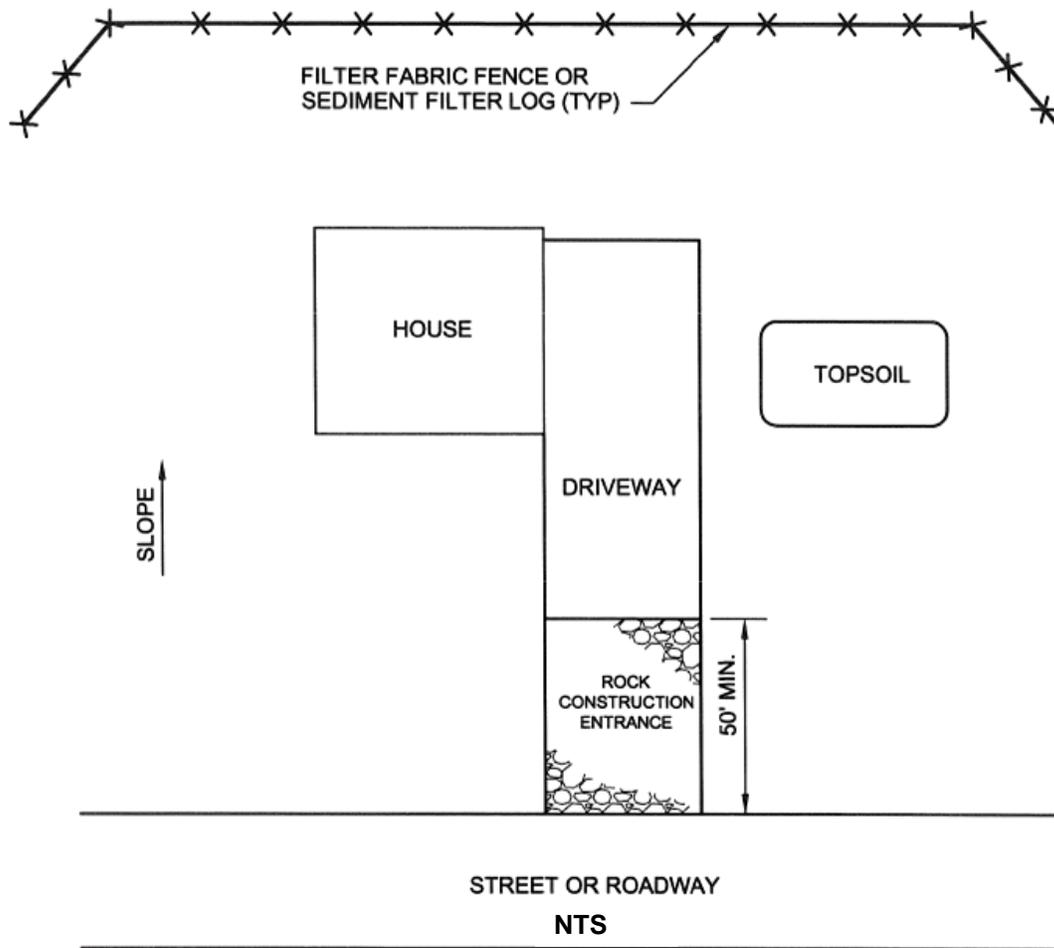
Wherever a lot is sloping toward the roadway, a layout as shown in Standard Construction Detail #10-1 should be used.



THE UPSLOPE DIVERSION CHANNEL SHOULD BE INSTALLED WHEREVER THE LOT EXTENDS MORE THAN 150 FEET ABOVE THE ROADWAY OR WHERE RUNOFF FROM AREAS ABOVE THE LOT IS NOT OTHERWISE DIVERTED AWAY FROM THE LOT. THE CHANNEL SHOULD BE PROPERLY SIZED AND PROVIDED WITH A SUITABLE PROTECTIVE LINING. THE DESIGNER MUST EXERCISE CAUTION TO PROTECT ALL DOWNSTREAM PROPERTY OWNERS WHEN SELECTING THE DISCHARGE POINT FOR THIS CHANNEL.  
PA DEP

Wherever a lot is sloping away from the roadway, a layout as shown in Standard Construction Detail #10-2 should be used.

### STANDARD CONSTRUCTION DETAIL #10-2 Typical On-lot BMPs for Lot Below Roadway

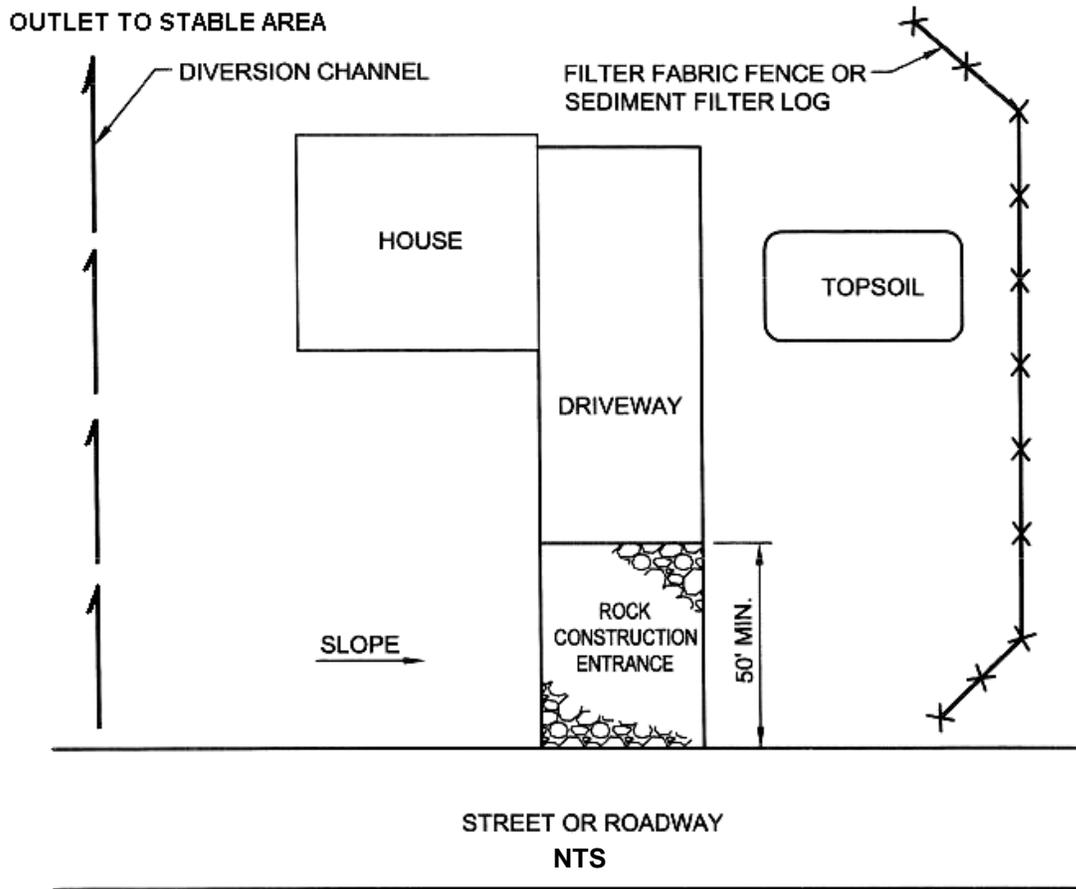


THE AREA DOWNSLOPE FROM THE FILTER FABRIC FENCE MAY NOT BE UNDER DEVELOPMENT OR OTHERWISE DISTURBED .

PA DEP

Wherever the slope parallels the roadway, a layout as shown in Standard Construction Detail #10-3 should be used.

**STANDARD CONSTRUCTION DETAIL #10-3  
Typical On-lot BMPs for Lot Along Ascending or Descending Roadway**



THE AREA DOWNSLOPE FROM THE FILTER FABRIC FENCE MAY NOT BE UNDER DEVELOPMENT OR OTHERWISE DISTURBED .

THE UPSLOPE DIVERSION CHANNEL SHOULD BE INSTALLED WHEREVER RUNOFF FROM AREAS ABOVE THE LOT IS NOT OTHERWISE DIVERTED AWAY FROM THE LOT. THE CHANNEL SHOULD BE PROPERLY SIZED AND PROVIDED WITH A SUITABLE PROTECTIVE LINING.

PA DEP

**In areas where slope is at an oblique angle to the roadway, BMPs shall be adjusted accordingly.**

**Diversion channel may outlet to roadside ditch or storm sewer system, but not onto street or roadway.**

## CHAPTER 11 - STABILIZATION METHODS AND STANDARDS

**GENERAL** - As soon as slopes, channels, ditches, and other disturbed areas reach final grade they must be stabilized. Upon completion or temporary cessation of the earth disturbance activity in a special protection watershed, that portion of the project site tributary to the special protection waters must be immediately stabilized. In all other watersheds, cessation of activity for at least 4 days requires temporary stabilization. Keeping stabilization current with earthmoving is recommended for all projects, regardless of watershed classification. This chapter is intended to provide guidance and specifications for stabilization as well as information that is useful in achieving stabilization in the least amount of time.



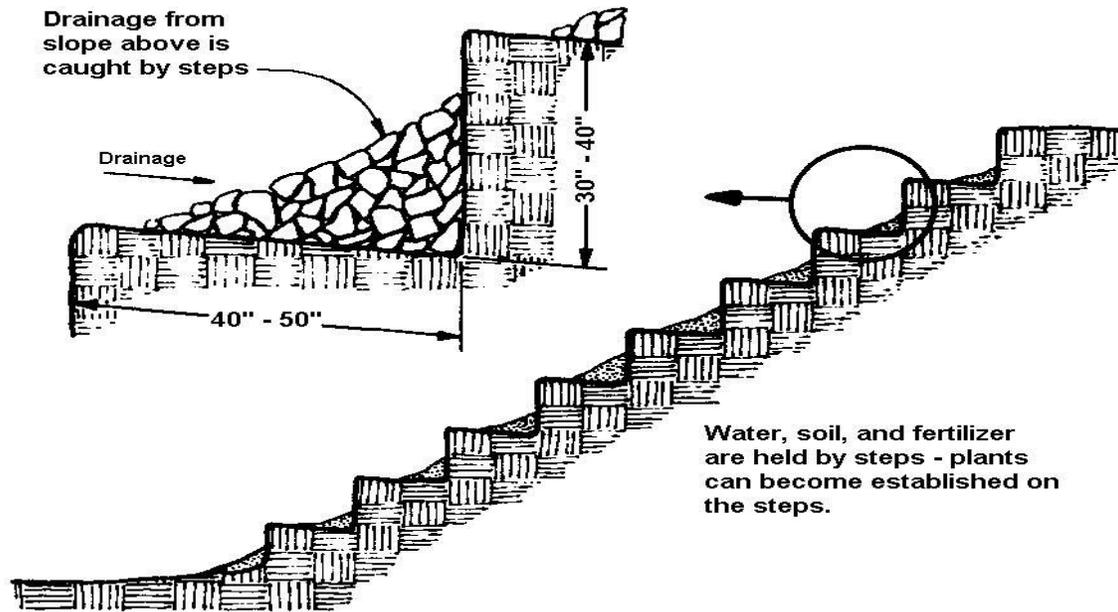
PA DEP

**SURFACE ROUGHENING** is the practice of providing a rough soil surface with horizontal depressions for the purpose of reducing runoff velocity, increasing infiltration, aiding the establishment of vegetation, and reducing erosion. Surface roughening should be applied to slopes 3H:1V or steeper unless a stable rock face is provided or it can be shown that there is not a potential for sediment pollution to surface waters. For roughened surfaces within 50 feet of a surface water, and where blanketing of seeded areas is proposed as the means to achieving permanent stabilization, spray-on type blankets are recommended. Details for stair stepping, grooving, and tracking are provided below.

**Stair step grading**, as shown in Figure 11.1, may be conducted on slopes having bedrock soft enough to be ripped by a bulldozer. It is appropriate for cut slopes 3H:1V or steeper that will not be mowed. Wherever stair step grading is used, the size of the horizontal cut should exceed that of the vertical cut by at least 10 inches. Individual vertical cuts should not exceed 30 inches in soft materials or 40 inches in harder rock. The horizontal cut should be graded toward the vertical cut (i.e. into the cut).



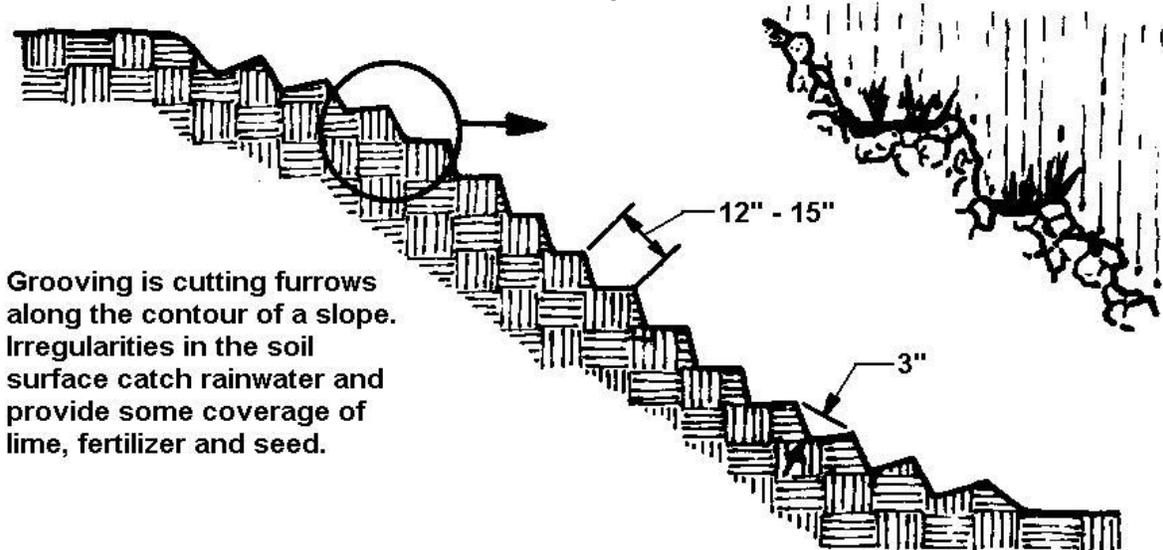
**FIGURE 11.1**  
**Stair Step Grading of Cut Slopes**



VA SWCC

**Grooving slopes** (Figure 11.2) consists of using machinery to create depressions parallel to contour along the slope. In softer materials, this may be done with discs, tillers, or harrows. The teeth of a wheeled or tracked loader may be used for harder materials. Grooves should be at least 3 inches deep and no more than 15 inches apart. Grooving is typically used on fill slopes gentler than 3H:1V.

**Figure 11.2**  
**Grooved Slope Details**

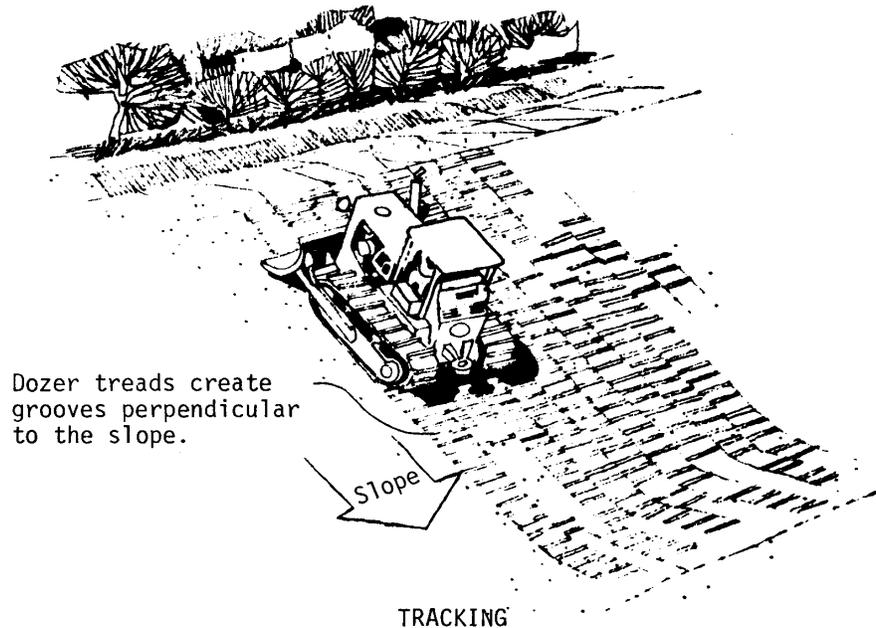


Grooving is cutting furrows along the contour of a slope. Irregularities in the soil surface catch rainwater and provide some coverage of lime, fertilizer and seed.

VA SWCC

**Tracking slopes**, as shown in Figure 11.3, is done by running tracked machinery up and down the slope, leaving tread marks parallel to the contour. Note: If a bulldozer is used, the blade should be up.

**FIGURE 11.3**  
**Tracking a Fill Slope**



Michigan Soil Erosion and Sedimentation Control Guidebook

## VEGETATIVE STABILIZATION

All disturbed areas that have not otherwise been stabilized and have significant potential for erosion should be stabilized with vegetation. This includes graded areas where it is anticipated that future earthmoving will take place within the coming year. Areas that will be subject to earthmoving within 12 months may be stabilized with temporary seed mixtures, predominantly annual grasses. All others should be stabilized with permanent seed mixtures — predominantly perennial grasses. When final grade is achieved during non-germinating months, the area should be mulched until the beginning of the next planting season. However, the area will not be considered stabilized until a minimum **uniform 70% vegetative cover of erosion resistant perennial species** has been achieved. Critical areas — erodible soils, within 50 feet of a surface water, etc. — should be blanketed. Temporary erosion control BMPs that were installed for the earthmoving phase of the project must remain in place and be maintained in working order until permanent stabilization is achieved. **NOTE: Areas that do not receive sufficient sunlight to support vegetation (e.g. under bridge decks) should be stabilized by some means other than vegetation.**

As disturbed areas within a project approach final grade, preparations should be made for seeding and mulching to begin (i.e. anticipate the completion date and schedule the seeder). In no case should an area exceeding 15,000 square feet, which is to be stabilized by vegetation, reach final grade without being seeded and mulched. Waiting until earthmoving is completed before making preparations for seeding and mulching is not acceptable. This requirement should be clearly stated in the seeding and mulching specifications contained on the plan drawings.

Before the seeding begins, topsoil should be applied and any required soil amendments worked into the soil to a depth of 4 to 6 inches. If compost is to be added to the topsoil, it should be worked into the soil with the other soil amendments unless it is being applied as an erosion control BMP.

## TOPSOIL APPLICATION

Graded areas should be scarified or otherwise loosened to a depth of 3 to 5 inches to permit bonding of the topsoil to the surface areas and to provide a roughened surface to prevent topsoil from sliding down slope.

Topsoil should be uniformly distributed across the disturbed area to a depth of 4 to 8 inches minimum — 2 inches on fill outslopes. Spreading should be done in such a manner that sodding or seeding can proceed with a minimum of additional preparation or tillage. Irregularities in the surface resulting from topsoil placement should be corrected in order to prevent formation of depressions unless such depressions are part of the PCSM plan.

Topsoil should not be placed while the topsoil or subsoil is in a frozen or muddy condition, when the subsoil is excessively wet, or in a condition that may otherwise be detrimental to proper grading and seedbed preparation. Compacted soils should be scarified 6 to 12 inches along contour wherever possible prior to seeding.

**TABLE 11.1**  
**Cubic Yards of Topsoil Required for Application to Various Depths**

<b>Depth (in)</b>	<b>Per 1,000 Square Feet</b>	<b>Per Acre</b>
1	3.1	134
2	6.2	268
3	9.3	403
4	12.4	537
5	15.5	672
6	18.6	806
7	21.7	940
8	24.8	1,074

Adapted from VA DSWC

**SEEDING** - Seed mixtures appropriate for site conditions (e.g. soil pH and fertility, slope, available sunlight, anticipated use, etc.) should be specified. Tables 11.3, 11.4 and 11.5, adapted from the Penn State Erosion Control and Conservation Plantings on Noncropland Manual, should be used for selection of species, seed specifications, mixtures, liming and fertilizing, time of seeding, and seeding methods. Specifications for these items may also be obtained from PennDOT's Publication # 408, Section 804 or from the local conservation district. Other sources can be approved on a case-by-case basis. Upon selection of a reference, that reference should be used to provide all specifications for seeding, mulching, and soil amendments unless otherwise approved. Indicate the reference being used in the plan submittal. Seed mixtures that contain potentially invasive species or species that may be harmful to native plant communities should be avoided. Standard E&S Worksheet #21 should be used to provide seeding, mulching and soil amendment specifications in the E&S plan. This information should be placed on one of the plan drawings.



Finn

Seeding rates are stated as pounds per acre (lb/A) of pure live seed (PLS). PLS is the product of the percentage of pure seed times the percentage of germination divided by 100 (e.g. [85% pure seed × 72% germination] ÷ 100 = 61% PLS). Seed should not be used later than one year after the test date that appears on the label. Use of seed older than one year could result in less than satisfactory vegetative coverage and the need to re-seed the disturbed area.

Actual seeding rates may be determined by dividing the PLS seeding rate by the %PLS shown on the seed tag, or calculated as shown above (e.g. for a PLS seeding rate of 12 lb/A from a seed lot with a PLS of 35%, the actual seeding rate is equal to  $12 \div 0.35 = 34.3$  lb/A). If more than one species is used, indicate the application rate for each species. A nurse crop may be necessary if the selected species do not rapidly germinate. If a nurse crop is used in conjunction with permanent seeding, the nurse crop should not hinder the establishment of the permanent vegetation. A nurse crop should not be applied at a rate exceeding 50% of its temporary seeding rate.

Legumes should be inoculated in accordance with the supplier's recommendations. Inoculants should not be mixed with liquid fertilizer.

The Department also recommends that soil testing be done prior to seeding and mulching to determine the proper soil amendments and application rates for the proposed seed mixture(s). Soil test kits are inexpensive and may be obtained from the county Cooperative Extension Service offices. When done properly, soil tests can actually save money that would otherwise be lost on improper soil amendments, unsuccessful seeding, and damage caused by erosion of unstabilized areas. In the absence of a soil test, soil amendments should be added at the rates specified by the selected seeding reference.

Site conditions such as soil limitations, wetness, steepness of slope, sun vs. shade, proximity to natural plant communities, proximity to nuisance, noxious and/or invasive species, site history, previous herbicide applications, and proposed land use should be considered in selecting seed mixtures.

Tables contained on the website maintained by the NRCS provide valuable information regarding soil use limitations. Soils designated as “infertile,” “wet,” “droughty,” “acid,” etc. should be given special attention when selecting seed mixtures. Table 11.3 identifies plant species which are tolerant or intolerant of these soil conditions.

Wherever seeding is to be done on steep slopes ( $\geq 3H:1V$ ), seed mixtures should be selected that are appropriate for steep slopes. Table 11.5 in this manual and Table A (Section 804.2(b)) in PennDOT’s publication 408 identify seed mixtures suitable for steep slope conditions. These tables also provide information regarding seed selection for various proposed land uses (e.g. mowed vs. unmowed, high traffic, etc.).

Fill slopes should be seeded and mulched at regular vertical increments — 15 to 25 feet maximum — as the fill is being constructed. This will allow the bottom of the fill to progress toward stabilization while work continues on the upper portion, making final stabilization easier to achieve and providing some vegetative buffering at the bottom of the slope.

Wherever seed and mulch is applied by hydroseeding methods, the seed and mulch should be applied in separate applications with the seed being applied first and the mulch sprayed on top of the seed. This is to ensure that the seed makes contact with the underlying soil. Soil preparation should be completed prior to adding seed to the hydroseeding equipment. Running seed through the pumping system can result in excessive abrasion of the seed and reduce the percentage of pure live seed in the application. Therefore all site preparation should be completed prior to the arrival of the hydroseeder.

In critical areas (e.g. adjacent to or within 50 feet of streams, ponds, or wetlands) a protective blanket should be provided for all seeded areas. Consideration should be given to use of mulch with netting or protective blankets for all seeded areas on slopes 3H:1V or steeper.

When wetland areas are temporarily disturbed, isolate and stockpile topsoil for replacement after grading is completed. In most cases, no seeding of the disturbed area is necessary after the topsoil is replaced. The soil contains sufficient seed and root material to reestablish vegetation. If temporary vegetative stabilization is necessary, apply annual ryegrass at the rate not exceeding 48 lb PLS/acre. Apply clean straw as a mulch at the rate of 3T /acre. No soil amendments should be used on wetland areas.

Show all seeding, mulching, and soil amendment specifications on a detail sheet. References to a standard seed mixture are not acceptable. The exception to this is for PennDOT, Pennsylvania Turnpike Commission, or Bureau of Abandoned Mine Reclamation or other agency projects using a standard seed mixture which is contained in the bid package. A copy of the seed mixture used in the bid package should be made available to the reviewing agency upon request.

The beginning and ending of the germination season for each of the proposed seed mixtures should be provided as well as directions for temporary stabilization of disturbed areas that achieve finished grade during non-germinating seasons.

Vehicular traffic should be restricted from areas to be seeded to prevent soil compaction.

**TABLE 11.2**  
**Soil Amendment Application Rate Equivalents**

Soil Amendment	Permanent Seeding Application Rate			Notes
	Per Acre	Per 1,000 sq. ft.	Per 1,000 sq. yd.	
Agricultural lime	6 tons	240 lb.	2,480 lb.	Or as per soil test; may not be required in agricultural fields
10-20-20 fertilizer	1,000 lb.	25 lb.	210 lb.	Or as per soil test; may not be required in agricultural fields
	Temporary Seeding Application Rate			
Agricultural lime	1 ton	40 lb.	410 lb.	Typically not required for topsoil stockpiles
10-10-10 fertilizer	500 lb.	12.5 lb.	100 lb.	Typically not required for topsoil stockpiles

Adapted from Penn State, "Erosion Control and Conservation Plantings on Noncropland"

**NOTE: A compost blanket which meets the standards of this chapter may be substituted for the soil amendments shown in Table 11.2.**

**TABLE 11.3**  
**Plant Tolerances of Soil Limitation Factors**

Species	Growth Habit <sup>1</sup>	Tolerates				Minimum Seed Specifications <sup>3</sup>				
		Wet Soil	Dry Site	Low Fertility	Acid Soil (pH 5-5.5) <sup>2</sup>	Purity (%)	Ready Germ (%)	Hard Seed (%)	Total Germ (%)	Seeds/lb (1,000s)
<b>Warm-Season Grasses</b>										
Deertongue	bunch	yes	yes	yes	yes	95	75		75	250
Weeping lovegrass	bunch	no	yes	yes	yes	97	75		75	1,500
Switchgrass <sup>4</sup>	bunch	yes	yes	yes	yes	(60 PLS)			390	
Big bluestem	bunch	no	yes	yes	yes	(60 PLS)			150	
<b>Cool-Season Grasses</b>										
Fine fescues	sod	no	no	yes	no	95	80		80	400
Perennial ryegrass	bunch	yes	no	no	no	95	85		85	227
Annual ryegrass	bunch	yes	no	yes	no	95	85		85	227
Kentucky bluegrass	sod	no	no	no	no	85	75		75	2,200
Reed canarygrass	sod	yes	yes	yes	no	95	70		70	520
Orchardgrass	bunch	yes	yes	yes	yes	95	80		80	654
Timothy	bunch	yes	no	yes	yes	95	80		80	1,230
Smooth bromegrass	sod	no	yes	yes	no	95	80		80	136
<b>Legumes<sup>5</sup></b>										
Flatpea	sod	no	no	yes	yes	98	55	20	75	10
Serecia lespedeza	bunch	no	yes	yes	yes	98	60	20	80	335
<b>Cereals</b>										
Winter wheat	bunch	no	no	no	no	98	85		85	15
Winter rye	bunch	no	no	yes	yes	98	85		85	18
Spring oats	bunch	no	no	no	no	98	85		85	13
Sundangrass	bunch	no	yes	no	no	98	85		85	55
Japanese millet	bunch	yes	no	yes	yes	98	80		80	155

- <sup>1</sup> Growth habit refers to the ability of the species to either form a dense sod by vegetative means (stolons, rhizomes, or roots) or remain in a bunch or single plant form. If seeded heavily enough, even bunch formers can produce a very dense stand. This is sometimes called a sod, but not in the sense of a sod formed by vegetative means.
- <sup>2</sup> Once established, plants may grow at a somewhat lower pH, but cover generally is only adequate at pH 6.0 or above.
- <sup>3</sup> *Minimum seed lots are truly minimum, and seed lots to be used for revegetation purposes should equal or exceed these standards.* Thus, deertongue grass should germinate 75% or better. Crownvetch should have at least 40% readily germinable seed and 30% hard seed. Commonly, seed lots are available that equal or exceed minimum specifications. Remember that disturbed sites are adverse for plant establishment. Ready germination refers to seed that germinates during the period of the germination test and that would be expected, if conditions are favorable, to germinate rapidly when planted. The opposite of ready germination is dormant seed, of which hard seed is one type.
- <sup>4</sup> Switchgrass seed is sold only on the basis of PLS.
- <sup>5</sup> Need specific legume inoculant. Inoculant suitable for garden peas and sweetpeas usually is satisfactory for flatpea.
- <sup>6</sup> Birdsfoot trefoil is adapted over the entire state, except in the extreme southeast where crown and root rots may injure stands.

Penn State, "Erosion Control and Conservation Plantings on Noncropland,"

**TABLE 11.4  
Recommended Seed Mixtures**

Mixture Number	Species	Seeding Rate - Pure Live Seed <sup>1</sup>	
		Most Sites	Adverse Sites
1 <sup>2</sup>	Spring oats (spring), or	64	96
	Annual ryegrass (spring or fall), or	10	15
	Winter wheat (fall), or	90	120
	Winter rye (fall)	56	112
2	Birdsfoot trefoil, plus	6	10
	Reed canarygrass	10	15
3	Deertongue, plus	15	20
	Birdsfoot trefoil	6	10
4 <sup>3</sup>	Switchgrass, or	15	20
	Big Bluestem, plus	15	20
	Birdsfoot trefoil	6	10
5	Orchardgrass, or	20	30
	Smooth bromegrass, plus	25	35
	Birdsfoot trefoil	6	10

Penn State, "Erosion Control and Conservation Plantings on Noncropland"

1. PLS is the product of the percentage of pure seed times percentage germination divided by 100. For example, to secure the actual planting rate for switchgrass, divide 12 pounds PLS shown on the seed tag. Thus, if the PLS content of a given seed lot is 35%, divide 12 PLS by 0.35 to obtain 34.3 pounds of seed required to plant one acre. All mixtures in this table are shown in terms of PLS.
2. If high-quality seed is used, for most sites seed spring oats at a rate of 2 bushels per acre, winter wheat at 1.5 bushels per acre, and winter rye at 1 bushel per acre. If germination is below 90%, increase these suggested seeding rates by 0.5 bushel per acre.
3. Do not mow shorter than 9 to 10 inches.

**TABLE 11.5  
Recommended Seed Mixtures for Stabilizing Disturbed Areas**

Site Condition	Nurse Crop	Seed Mixture (Select one mixture)
<b>Slopes and Banks (not mowed)</b>		
Well-drained	1 plus	3, 5, 8, or 12 <sup>1</sup>
Variable drainage	1 plus	3 or 7
<b>Slopes and Banks (mowed)</b>		
Well-drained	1 plus	2 or 10
<b>Slopes and Banks (grazed/hay)</b>		
Well-drained	1 plus	2, 3, or 13
<b>Gullies and Eroded Areas</b>	1 plus	3, 5, 7, or 12 <sup>1</sup>
<b>Erosion Control Facilities (BMPs)</b>		
Sod waterways, spillways, frequent water flow areas	1 plus	2, 3, or 4
Drainage ditches		
Shallow, less than 3 feet deep	1 plus	2, 3, or 4
Deep, not mowed	1 plus	5 or 7
Pond banks, dikes, levees, dams, diversion channels, And occasional water flow areas		
Mowed areas	1 plus	2 or 3
Non-mowed areas	1 plus	5 or 7
For hay or silage on diversion channels and occasional water flow areas	1 plus	3 or 13
<b>Highways <sup>2</sup></b>		
Non-mowed areas		
Pure crownvetch <sup>3</sup>	1 plus	5 or 6
Well-drained	1 plus	5, 7, 8, 9, or 10



Variable drained	1 plus	3 or 7
Poorly drained	1 plus	3 or 4
Areas mowed several times per year	1 plus	2, 3, or 10
<b>Utility Right-of-way</b>		
Well-drained	1 plus	5, 8, or 12 <sup>1</sup>
Variable drained	1 plus	3 or 7
Well-drained areas for grazing/hay	1 plus	2, 3, or 13
<b>Effluent Disposal Areas</b>	1 plus	3 or 4
<b>Sanitary Landfills</b>	1 plus	3, 5, 7, 11 <sup>1</sup> , or 12 <sup>1</sup>
<b>Surface mines</b>		
Spoils, mine wastes, fly ash, slag, settling basin		
Residues and other severely disturbed areas (lime to soil test)	1 plus	3, 4, 5, 7, 8, 9, 11 <sup>1</sup> , or 12 <sup>1</sup>
Severely disturbed areas for grazing/hay	1 plus	3 or 13

Penn State, "Erosion Control and Conservation Plantings on Noncropland"

1. For seed mixtures 11 and 12, only use spring oats or weeping lovegrass (included in mix) as nurse crop.
2. Contact the Pennsylvania Department of Transportation district roadside specialist for specific suggestions on treatment techniques and management practices.
3. Seed mixtures containing crown vetch should not be used in areas adjacent to wetlands or stream channels due to the invasive nature of this species.

**MULCHING** - Mulches absorb rainfall impact, increase the rate of infiltration, reduce soil moisture loss due to evaporation, moderate soil temperatures, provide a suitable environment for germination, and protect the seedling from intense sunlight. All seeded areas should be mulched or blanketed to minimize the potential for failure to establish an adequate vegetative cover. Mulching may also be used as a temporary stabilization of some disturbed areas in non-germinating seasons.

**FIGURE 11.4**  
**Straw Mulch Applied at 3 Tons/Acre**



PA DEP

**Rule of thumb: If you are seeing a lot of bare ground, there is not enough straw.  
(Caution: Too much straw can be as harmful as too little straw.)**

Mulches should be applied at the rates shown in Table 11.6

Straw and hay mulch should be anchored or tackified immediately after application to prevent being windblown. A tractor-drawn implement may be used to “crimp” the straw or hay into the soil — about 3 inches. This method should be limited to slopes no steeper than 3H:1V. The machinery should be operated on the contour. Note: Crimping of hay or straw by running over it with tracked machinery is not recommended.

Polymeric and gum tackifiers mixed and applied according to manufacturer’s recommendations may be used to tack mulch. Avoid application during rain and on windy days. A 24-hour curing period and a soil temperature higher than 45° F are typically required. Application should generally be heaviest at edges of seeded areas and at crests of ridges and banks to prevent loss by wind. The remainder of the area should have binder applied uniformly. Binders may be applied after mulch is spread or sprayed into the mulch as it is being blown onto the soil. Applying straw and binder together is generally more effective.

Synthetic binders, or chemical binders, may be used as recommended by the manufacturer to anchor mulch provided sufficient documentation is provided to show they are non-toxic to native plant and animal species.

Mulch on slopes of 8% or steeper should be held in place with netting. Lightweight plastic, fiber, or paper nets may be stapled over the mulch according to manufacturer's recommendations.

Shredded paper hydromulch should not be used on slopes steeper than 5%. Wood fiber hydromulch may be applied on steeper slopes provided a tackifier is used. The application rate for any hydromulch should be 2,000 lb/acre at a minimum.

**TABLE 11.6  
Mulch Application Rates**

Mulch Type	Application Rate (Min.)			Notes
	Per Acre	Per 1,000 sq. ft.	Per 1,000 sq. yd.	
Straw	3 tons	140 lb.	1,240 lb.	Either wheat or oat straw, free of weeds, not chopped or finely broken
Hay	3 tons	140 lb.	1,240 lb.	Timothy, mixed clover and timothy or other native forage grasses
Wood Chips	4 - 6 tons	185 - 275 lb.	1,650 - 2,500 lb.	May prevent germination of grasses and legumes
Hydromulch	1 ton	47 lb.	415	See limitations above

**COMPOSTING** - Compost has been shown to be an effective means of temporary stabilization for some areas that are to be vegetated. In addition to holding soil particles in place while vegetation becomes established, it has the added benefits of providing filtering of water infiltrating the soil, increased retention of soil moisture, and providing some plant nutrients.



Source Unknown

## **MATERIAL**

Compost material should be as described in Table 4.2.

### **COMPOST FOR EROSION CONTROL**

When used as a mulch replacement, the application rate (thickness) of the compost should be  $\frac{1}{2}$ " to  $\frac{3}{4}$ ". Compost is not recommended for slopes steeper than 2H:1V unless a netting or confinement system is used in conjunction with the compost.

Compost should be placed evenly and should provide 100% soil coverage. No soil should be visible. On highly unstable soils, use compost in conjunction with appropriate structural measures. Spread the compost uniformly, and then track, or compact, the compost layer using a bulldozer or other appropriate equipment. Alternatively, apply compost using a pneumatic, or blower, unit. Project compost directly at soil, thereby preventing water from moving between the soil-compost interface. Apply compost layer approximately 3 feet beyond the top of the slope or overlap it into existing vegetation. Follow by seeding or ornamental planting.

Where planning immediate grass, wildflower, or legume seeding or ornamental planting, use only a well-composted product that contains no substances toxic to plants. Very coarse composts should be avoided if the slope is to be landscaped or seeded, as it will make planting and crop establishment more difficult. Composts containing fibrous particles that range in size produce a more stable mat.

Note: Compost should not be used instead of erosion control blanketing.

**EROSION CONTROL BLANKETS** - There are many varieties of erosion control blankets on the market. They range from rolls of natural and artificial materials, which are typically installed by hand, to liquid, spray-on, materials that make use of a bonding agent to hold natural or artificial fibers in place until vegetation becomes established. Erosion control blankets should be used on all slopes that are 3H:1V or steeper and where potential exists for sediment pollution to receiving surface waters. Since rock slopes pose little, if any, potential for erosion, cut slopes in competent bedrock and rock fill slopes need not be blanketed. Erosion control blankets should be used for all seeded areas within 50 feet of a surface water — 100 feet of a special protection water — regardless of slope.



Source Unknown

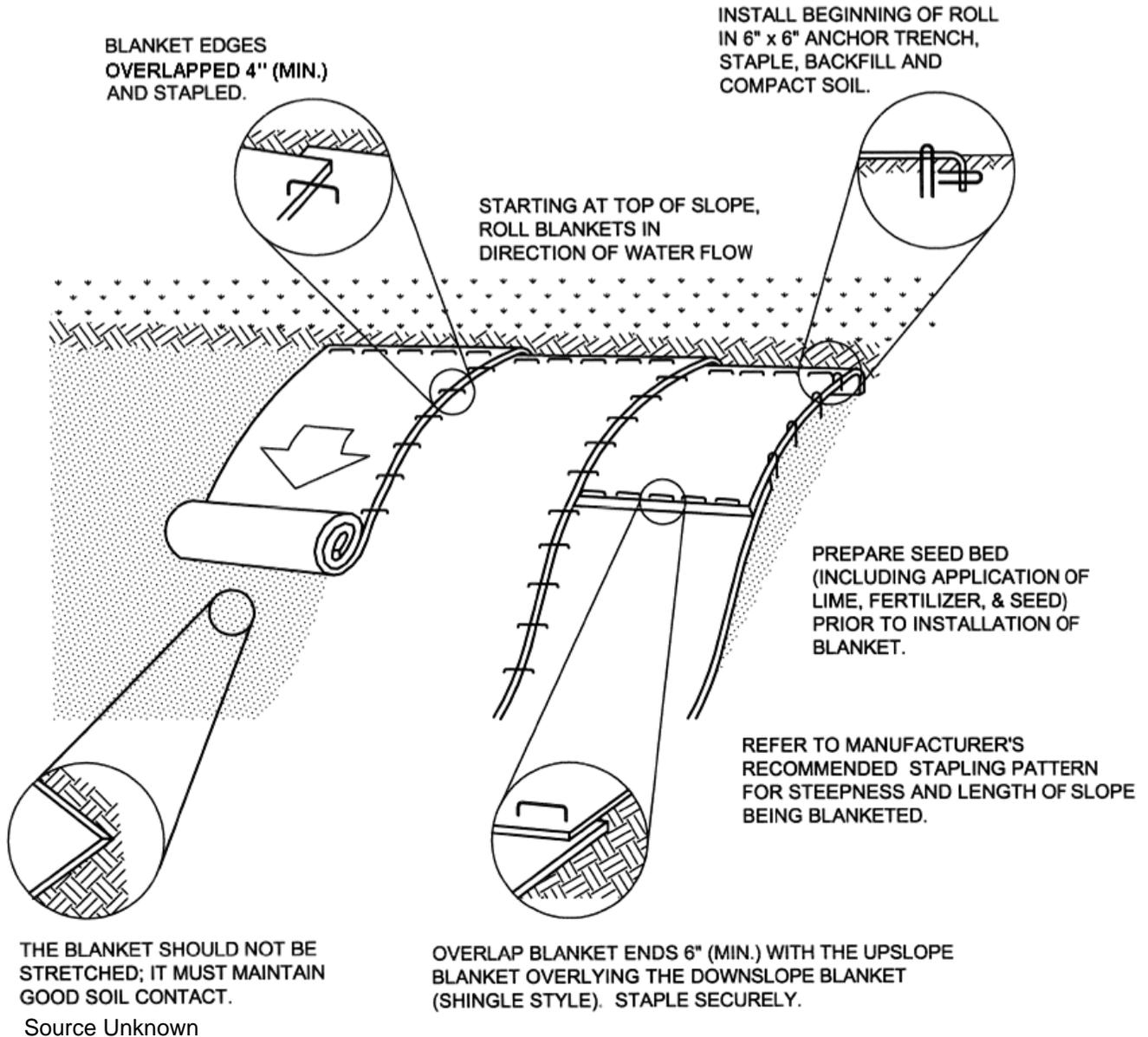
The E&S plan should address how runoff from disturbed areas will be handled prior to the erosion control blanket being installed. Erosion control blankets should also be considered where soil conditions (e.g. low fertility, droughty conditions, erodibility, etc.) make revegetation difficult. When properly installed, erosion control blankets can help hold soil particles in place and retain soil moisture, promoting seed germination. The blanket also provides the seedlings protection from intense sunlight during early stages of growth. A temporary blanket is necessary where vegetation is proposed as the protective lining for waterways.

Erosion control blankets are NOT effective in preventing slope failures. Wherever slope stability problems are anticipated or encountered, appropriate measures such as reducing steepness of slope, diverting upslope runoff, reducing soil moisture, loading the toe, or buttressing the slope should be considered.

Wherever erosion control blankets are specified, they should be installed or applied according to the manufacturer's recommendations. For rolled blankets, the areas to be blanketed should be smooth and uniform to ensure continuous contact between the blanket and the underlying soil. Smoothing the surface is not required for spray-on blankets. However, extra care is necessary for extremely rough surfaces to ensure continuous coverage.

A copy of the installation/application procedure should be included in the E&S Plan on a detail sheet. If the specific product that will be used cannot be identified in the E&S plan, the minimum standards for the product that will be used should be provided.

## STANDARD CONSTRUCTION DETAIL # 11-1 Erosion Control Blanket Installation



Seed and soil amendments shall be applied according to the rates in the plan drawings prior to installing the blanket.

Provide anchor trench at toe of slope in similar fashion as at top of slope.

Slope surface shall be free of rocks, clods, sticks, and grass.

Blanket shall have good continuous contact with underlying soil throughout entire length. Lay blanket loosely and stake or staple to maintain direct contact with soil. Do not stretch blanket.

The blanket shall be stapled in accordance with the manufacturer's recommendations.

Blanketed areas shall be inspected weekly and after each runoff event until perennial vegetation is established to a minimum uniform 70% coverage throughout the blanketed area. Damaged or displaced blankets shall be restored or replaced within 4 calendar days.

## HYDRAULICALLY APPLIED BLANKETS

**Hydraulically applied blankets should not be used in areas of concentrated flow (e.g. channels).**

A **Bonded Fiber Matrix (BFM)** can be an effective method of stabilizing steep slopes when used properly. BFMs make use of a cross-linked hydrocolloid tackifier to bond thermally processed wood fibers. Application rates vary according to site conditions. For slopes up to 3H:1V the BFM should be applied at a rate of 3,000 lb/acre. Steeper slopes may need as much as 4,000 lb/acre. In any case, manufacturer's recommendations should be followed.



PA DEP

BFMs should only be used when no rain is forecast for at least 48 hours following the application. This is to allow the tackifier sufficient time to cure properly. Once properly applied, a BFM is typically 90% effective in preventing accelerated erosion. **Bonded Fiber Matrix should not be applied between September 30 and April 1.**

Other fiber matrices that have been shown to be effective in preventing erosion on disturbed surfaces may be used in accordance with manufacturer's recommendations if sufficient supporting documentation is provided.

A **Flexible Growth Medium (FGM)** has the added component of ½ inch long, crimped organic or manmade fibers which add a mechanical bond to the chemical bond provided by BFMs. This increases the blanket's resistance to both raindrop impact and erosion due to runoff. Unlike BFMs, a flexible growth medium typically does not require a curing time to be effective. Properly applied, an FGM may be as much as 99% effective.

A **Polymer Stabilized Fiber Matrix (PSFM)** can also be an effective method of stabilizing steep slopes when used properly. PSFMs make use of a linear soil stabilizing tackifier that works directly on soil to maintain soil structure, maintain pore space capacity and flocculate dislodged sediment that will significantly reduce runoff turbidity. Properly applied, a PSFM may be as much as 99% effective.

PSFMs can be used in re-vegetation applications and for site winterization and/or dormant seeding — fall planting for spring germination — applications. Application rates vary according to site conditions

and the following application rates are suggested. In any case, manufacturer's recommendations should be followed. The following are typical application rates:

**TABLE 11.7  
Typical Polymer Stabilized Fiber Matrix Application Rates**

<b>Maximum Rainfall of ≤ 20"</b>							
<b>SLOPE</b>	6:1	5:1	4:1	3:1	2:1	1.5:1	1:1
<b>Soil Stabilizer (gals/acre)</b>	4	5	6	7	8	9	10
<b>Fiber (lb/acre)</b>	1,500	1,500	1,500	1,800	2,000	2,500	3,000

<b>Maximum Rainfall of &gt; 20" and for Site Winterization</b>			
<b>SLOPE</b>	≤5:1	4:1	≥3:1
<b>Soil Stabilizer (gals/acre)</b>	6	8	10
<b>Fiber (lb/acre)</b>	2,000	2,500	3,000

Unlike rolled blankets, there is no need to smooth the slope prior to application of hydraulically applied blankets. In fact some roughening of the surface, either natural or mechanically induced, is preferable. However, large rocks, those ≥ 9 inches, and existing rills should be removed prior to application. Tracking or grooving of slopes should be considered to slow water flows during a storm event. Slope interruption devices such as stair step grading or benching should be applied prior to the application. Mixing and application rates should follow manufacturer's recommendations.

Hydraulically applied blankets are typically applied in two stages. Unless specifically recommended to be applied in one application by the manufacturer, the seed mixture and soil amendments should be applied first. If the seed is applied at the same time as the hydraulically applied blanket, the bonded fibers may keep the seed from making sufficient contact with the soil to germinate. After the seed mixture is applied, the BFM, FGM, or PSFM should be sprayed over the area at the required application rate.

**SOIL BINDERS**

There are a number of soil binders, chemical stabilizers, or soil palliatives available from various manufacturers that provide temporary stabilization. Most of these are designed to be sprayed onto the soil surface with little or no preparation. When using a spray-on soil binder, care should be taken to make sure that the product is nontoxic and that it will allow any proposed vegetation to penetrate the binder. Product test data should be included in the narrative and specifications provided on the detail sheets of the E&S plan. Follow manufacturer's recommendations for application method and rate of application.

Water-soluble anionic polyacrylamide (PAM) may be applied to a disturbed area as a temporary soil-binding agent to reduce erosion due to wind and water. This practice is recommended for areas where timely establishment of a vegetative cover is not feasible (e.g. non-germinating season), wherever soils have high clay content, or where the vegetative cover is inadequate to provide protection from erosion. Wherever used, the application must comply with all federal, state and local laws and regulations governing anionic PAM.



## **PAM Specifications**

- Anionic PAM mixtures must be environmentally safe and non-toxic to fish and other aquatic species, wildlife, and plants. It should also be non-combustible.
- Cationic PAM may not be used due to its toxicity to aquatic species.
- Anionic PAM mixtures must have  $\leq 0.05\%$  free acrylamide monomer by weight as established by the Food and Drug Administration (FDA) and the Environmental Protection Agency (EPA).
- Acute toxicity test data should be provided from each manufacturer or supplier.
- The manufacturer should provide a product expiration date for anionic PAM based upon expiration of PAM in the pure form.

## **Application**

- Anionic PAM should be applied in accordance with the recommended methods provided by the manufacturer or supplier for the specific site conditions (e.g. slope and soil type). A record of the application, including the date of application, product type, weather conditions, method of application, and the name of the applicator, should be kept on site.
- Application rates should not exceed the manufacturer's recommendations. Repeated applications may be made if necessary to ensure adequate coverage.
- The application method used should provide uniform coverage to the target area while avoiding drift to non-target areas, especially paved areas.
- Manufacturer's recommendations for safe storage, mixing, and use of the product should be followed.
- Use of anionic PAM should be in conjunction with the other BMPs specified in the approved E&S Plan.
- Anionic PAM may not be used instead of a protective liner in a channel or in place of mulch on a seeded area. However, seed may be added to the mixture at the time of application.
- Disposal of excess material must be in accordance with manufacturer's recommendations as well as federal, state, and local laws and regulations.
- Anionic PAM may not be applied within the floodway of a receiving stream channel or within 25 feet of other water bodies.
- Anionic PAM may be used to temporarily stabilize topsoil stockpiles. However, anionic PAM may lose its effectiveness in as little as two months. Therefore, it might become necessary to reapply the mixture.
- Anionic PAM is not recommended for application on surfaces of pure sand or gravels with no fines or on snow-covered surfaces.
- A visible tracer or colorant may be added to the mixture to visually track its application.

SODDING is the laying of a continuous cover of grass sod over exposed soils. It can be an effective means of quickly establishing vegetative cover over a disturbed area. Sodding is appropriate for:

- Residential or commercial lawns and golf courses where prompt use and aesthetics are important
- Steep slopes (up to 2H:1V if not mowed, 3H:1V if mowed)
- Waterways and channels having intermittent flows
- Areas around drop inlets

Sod can be laid during times of the year when seeded grasses are likely to fail. The sod should be watered frequently during the first few weeks after installation. The type of sod used should be composed of plants adapted to the site conditions (e.g. dry or wet, full sun or shade, gentle slopes or steep, etc.). Care must be taken to ensure that the sod is free of noxious weeds, diseases, and insects. It should be machine cut at a uniform soil thickness of 0.5 to 1.0 inch — excluding top growth or thatch — at the time of installation. For best results, the sod should be harvested, delivered, and installed within 36 hours. Avoid planting when subject to frost heave.



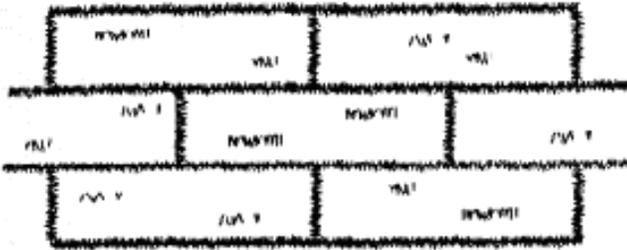
Source Unknown

Topsoil should be applied and prepared as described on page 263 prior to sod placement. Failure to properly prepare the soil before sod is placed could result in failure of the sod itself. Soils with excessive sand content might not provide sufficient moisture holding capacity. Sodding should not be done when the underlying soil is excessively wet. The sod type should consist of plant materials suitable to the site conditions as listed in Table 11.5.

Sod strips should be laid in a staggered pattern, as shown in Figure 11.5, with the ends butted tightly together. Sod strips cut by an automatic sod cutter should have the ends matched correctly as shown. Once the sod is placed, it should be rolled or tamped to achieve firm contact with the underlying soil. After rolling, the sod should be pegged or stapled to hold it in place if located on a slope. Before mowing, the sod should be carefully inspected to ensure no pegs or staples are protruding.

After the first growing season, the sod should be inspected to determine if additional fertilization or liming is needed. Permanent fine turf areas require yearly maintenance fertilization. Warm season grasses should be fertilized in late spring to early summer, while cool-season grasses should be fertilized in late winter and again in early fall.

**FIGURE 11.5  
Sodding**



**LAY SOD IN A STAGGERED PATTERN. BUTT THE STRIPS TIGHTLY AGAINST EACH OTHER. DO NOT LEAVE SPACES AND DO NOT OVERLAP.**

**INCORRECT**



**BUTTING** - ANGLED ENDS CAUSED BY THE AUTOMATIC SOD CUTTER MUST BE MATCHED CORRECTLY.

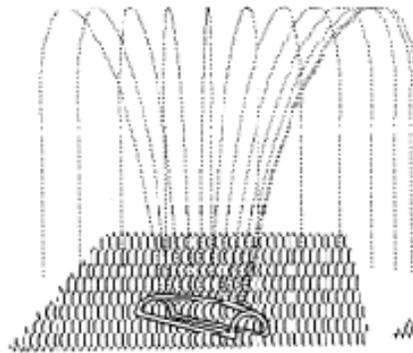
**CORRECT**



**SOD SHOULD BE PEGGED OR STAPLED TO HOLD IT IN PLACE IF LOCATED ON A SLOPE. BEFORE MOWING, THE SOD SHOULD BE CAREFULLY INSPECTED TO ENSURE NO PEGS OR STAPLES ARE PROTRUDING.**



**ROLL SOD IMMEDIATELY TO ACHIEVE FIRM CONTACT WITH THE SOIL**

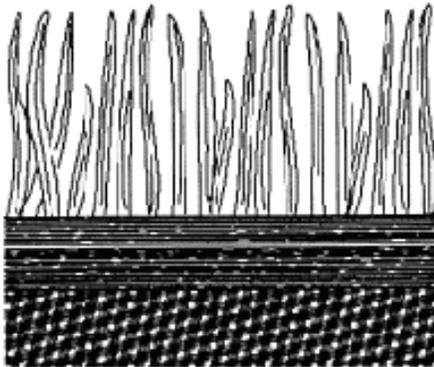


**WATER TO A DEPTH OF 1" AS NEEDED. WATER WELL AS SOON AS THE SOD IS LAID.**



**MOW WHEN THE SOD IS ESTABLISHED - IN 2-3 WEEKS. SET THE MOWER HIGH (2" - 3")**

**APPEARANCE OF GOOD SOD**



**SHOOTS** OR GRASS BLADES. GRASS SHOULD BE GREEN AND HEALTHY, MOWED AT A 2" - 3" CUTTING HEIGHT.

**THATCH** - GRASS CLIPPINGS AND DEAD LEAVES, UP TO 1/2" THICK.

**ROOT ZONE** - SOIL AND ROOTS. SHOULD BE 1/2" - 3/4" THICK. WITH DENSE ROOT MAT FOR STRENGTH

Adapted from VA DSWC

CELLULAR CONFINEMENT SYSTEMS are three-dimensional, honeycombed sheets, mats, or interlocking structures filled with soil, gravel, concrete, or other material. They are used to stabilize the surface of cut and fill slopes, streambanks, or natural slopes. They may also be used to increase the load-bearing capacity of a roadway or to create a permeable pavement system. The honeycomb-shaped cells encapsulate and prevent erosion of the infill material, making it an appropriate method of stabilizing high volume or high velocity channels.

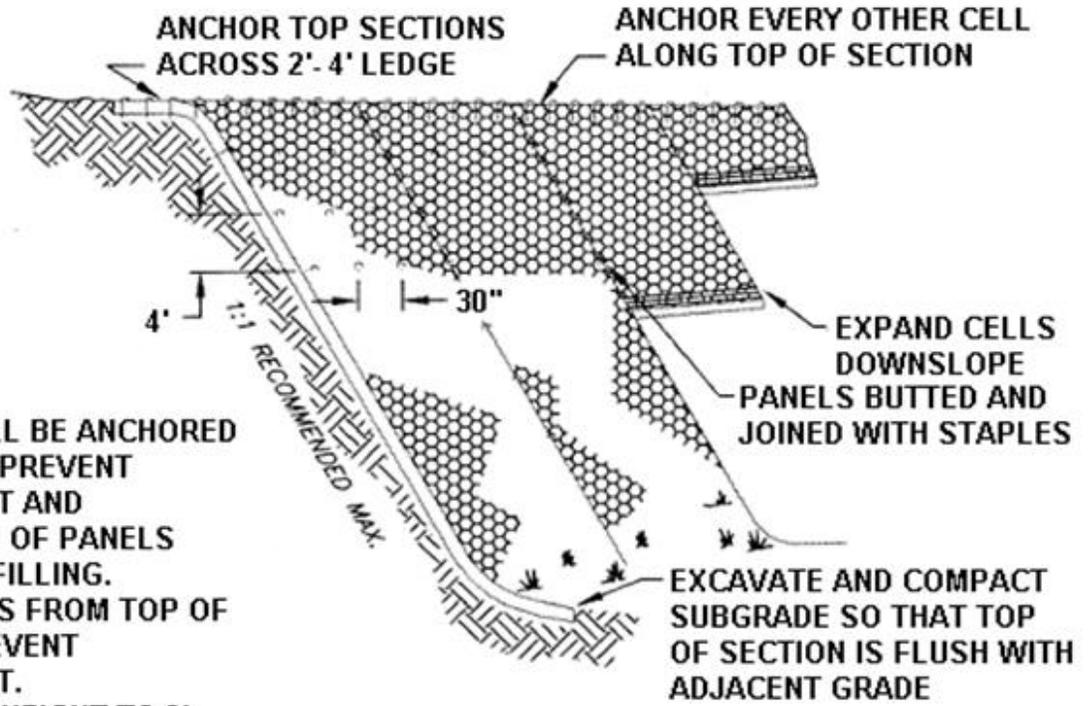


Geosynthetics

Manufacturer's recommendations should be followed regarding application, slope limits, installation procedure and appropriate fill material. It is important that the cells be properly anchored in order to prevent deformation or sliding of the panel. Therefore, cellular confinement systems should not be used where soil or rock conditions prevent installation of the anchoring pins in the required pattern.

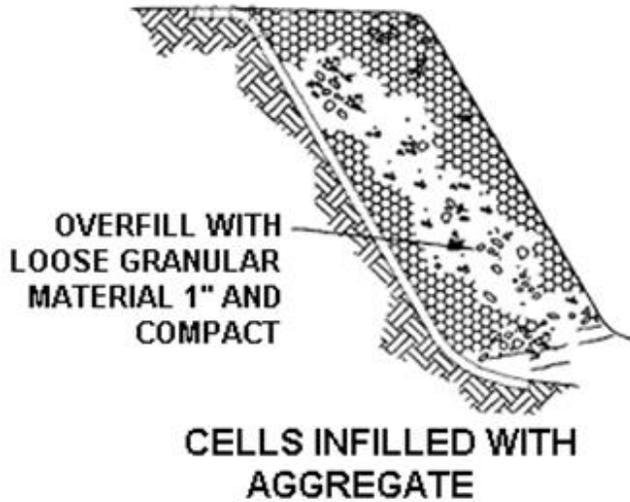
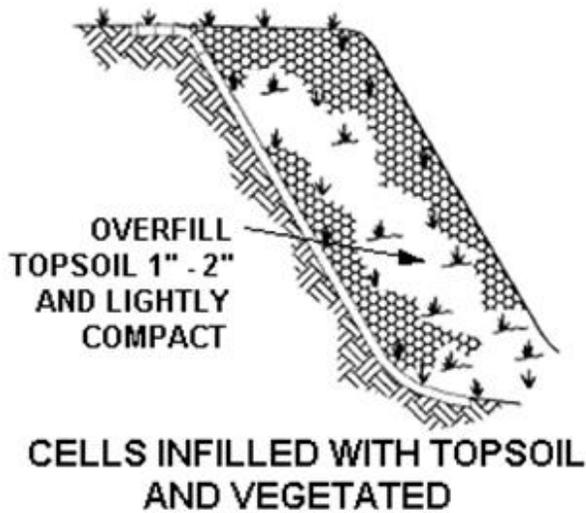
When filling the cells, care should be taken to avoid damaging them. Limit drop heights to 3 feet or less.

**FIGURE 11.6**  
**Typical Cellular Confinement System Installation**



- NOTES:**
1. CELLS SHALL BE ANCHORED SECURELY TO PREVENT DISPLACEMENT AND DEFORMATION OF PANELS DURING BACKFILLING.
  2. INFILL CELLS FROM TOP OF SLOPE TO PREVENT DISPLACEMENT.
  3. LIMIT DROP HEIGHT TO 3' MAX.

**DRAWINGS NOT TO SCALE**



## CHAPTER 12 - NEW PRODUCTS AND PROCEDURES

The BMPs set forth in this manual should be appropriately incorporated into all E&S plans unless the designer shows that alteration of these BMPs or inclusion of other BMPs will effectively minimize accelerated erosion and sedimentation as well as, or better than, the BMPs in this manual. Since the burden of proof concerning the effectiveness of a proposed new product or procedure lies with the designer, all necessary information required to approve the use of the new product or procedure should be submitted as part of the application. At a minimum, this should include:

1. The name of the product and type of control if a brand name is used.
2. Proposed use (e.g. storm sewer inlet protection). If this product or procedure has the potential to minimize accelerated erosion and sedimentation more effectively or efficiently than current methods, this should be stated and the reason given (e.g. same protection for less cost, less maintenance required, etc.). It should be demonstrated that the proposed use meets with any manufacturer's recommendations (e.g. copy of manufacturer's brochure showing such use, test data, limitations, etc.).
3. Where the proposed use is in a special protection watershed or a critical area (e.g. within 50 feet of a stream channel or wetland, or where no vegetative filter exists between the work area and the receiving surface water), an alternative conventional BMP should be specified for immediate installation should the innovative product or procedure fail. The definition of a product failure should be clearly stated.
4. Sufficient installation information should be provided to ensure its proper use. This should include a clear, concise sequence as well as a typical detail showing all critical dimensions and/or elevations.
5. The plan maps should show all locations where the proposed new product or procedure will be used. All receiving surface waters should be identified. Any downstream public water supplies, fish hatcheries, or other environmentally sensitive facilities should be noted.
6. A suitable maintenance program should be provided. Specific instructions, which identify potential problems and recommended remedies, should be included.

New products and procedures which meet the above criteria will be reviewed on a case-by-case basis until their effectiveness has been sufficiently demonstrated by successful use in the field.

Applicants seeking approval to use a new product or procedure should submit their request along with all pertinent drawings, details, supporting calculations, manufacturer's recommendations, etc. to the local conservation district, the appropriate regional Department office — Waterways Engineering and Wetlands, and the Department area engineer responsible for the part of the state in which the project is located (i.e. California, Altoona, or Reading office).

## CHAPTER 13 - UTILITY LINE PROJECTS

Since utility line construction tends to be repetitive, the construction sequence can usually be generalized. However, enough information should be provided to identify the BMPs that will be in place during each of the following phases of construction: clearing and grubbing, initial grading, trenching operations, backfilling, and during final stabilization. A time frame should be provided for construction from initial disturbance to seeding and mulching at any station along the right-of-way. The length of right-of-way disturbed at any one time should be the minimum required to efficiently construct the proposed utility line. This allowable length of disturbance should be specified in the E&S plan.



Source Unknown

Utility lines with joints that allow a manufactured length of pipe to be placed in the trench with the pipe joint assembled/made in the trench require an open trench that is only slightly longer than the length of pipe being installed. The total length of excavated trench open at any one time should not be greater than the total length of utility line that can be placed in the trench and back-filled in one working day. No more than 50 lineal feet of open trench should exist when utility line installation ceases at the end of the workday. Soil supplements, seed and mulch must be applied according to 25 Pa. Code §102.22.

Steel pipelines with welded joints typically require a relatively long open trench. For such installations, the length of time required for open trench operations at any station along the right-of-way should be specified in the E&S Plan. This time period should be the minimum time necessary to efficiently excavate the trench, install the pipe, backfill the trench and begin stabilization of the disturbed areas. For most installations, this time period should not exceed 30 calendar days. Longer time periods may be approved on a case-by-case basis where sufficient justification is provided (e.g. tie-ins, crossovers, interconnects and junctions). Stream and wetland crossings have different standards addressed below.

The locations, spacing, etc. of proposed BMPs should be shown on the plan drawings, maps, and/or profile sections.

All surface waters, as defined in 25 Pa. Code § 102.1, which could be affected by the proposed earthmoving should be shown on the plan maps. Trench plugs should be installed on both sides of all crossings to prevent draining streams or wetlands, and to prevent changes to their hydrology. Specific instructions should be provided for each type of water crossing anticipated, such as major streams, minor streams, swales, wetlands, etc. Site specific wetland and stream crossing may be requested by the Department or conservation district for review. All appropriate Chapter 105 permits must be obtained prior to initiating any stream or wetland crossing by pipeline, utility line, or access road.

### ROADWAY CROSSINGS

The types and locations of control measures needed at roadway crossings depends upon the slope of the land and types of roadway drainage systems present at that location. Upslope runoff should be diverted around the work area by use of waterbars. Sediment barriers should be located downslope of trench or boring pit storage piles. Such storage piles may not be located in any roadway swale or ditch or within 10 feet of a stream. Runoff from existing roadway culverts, storm sewers, swales, and ditches should be safely conveyed over any open trench. Suitable inlet protection should be provided for any storm sewer inlet that may receive runoff from a disturbed area.

Specific instructions should also be given for each type of roadway crossing with particular attention given to roadway drainage structures, such as channels, ditches, sewer lines, etc. A typical detail should be provided for each type of roadway crossing, such as trench, boring, etc.

### STREAM CROSSINGS



Source Unknown

**Horizontal directional drilling (HDD)** has been used as an effective technique for the installation of pipelines and other utilities in sensitive or congested areas, including streams and wetlands. As the drainage area for a waterway increases, open-cut methods become less practical and HDD becomes



more viable. HDD may be considered an ABACT BMP in special protection watersheds when implemented properly. However, HDD has its risks and there are certain erosion and sediment control issues that need to be properly addressed. The two major E&S issues with HDD are associated with the drilling mud and the exposure of the workspace, which is often in close proximity to sensitive areas such as streams and wetlands.

- Drilling mud must be properly managed through appropriate sediment removal BMPs such as a pumped water filter bag, as described in Standard Construction Detail #3-16, or Compost Sock Trap, as described in Standard Construction Detail #3-11. If the volume of drilling mud is too great or the composition such that it cannot be treated by either method, which may include HDD operations utilizing bentonite, it must be captured and removed from site or otherwise directed to a suitable treatment facility. If chemicals other than water are added to the drilling mud, all fluids must be captured and removed from site to a suitable treatment facility.
- Dry material removed from the drill hole must be placed out of the floodway of the stream or set back at least 10 feet from a wetland. A sediment barrier must be placed between the stockpile and the water body.
- Workspace for an HDD may require clearing and grading, depending on the entry and exit sites selected for the drill. Since the drill entry location has to accommodate the drill rig and supporting equipment, the entry side location requires satisfactory access as well as stable ground conditions to support heavy equipment. The drill exit side is usually the location for the fabrication of the pipe string as well as the location where the pipe string is inserted into the bore hole. The workspace required is typically longer to accommodate the pipe string and may require extra temporary workspace. Proper E&S BMPs must be incorporated into both disturbed areas. Depending upon the need for temporary staging, these areas can be larger than the permanent pipeline/utility line right-of-way.

Due diligence should be performed prior to initiating the drilling to determine whether geologic or hydro-geologic conditions at the proposed crossing could result in an inadvertent return (discharge) of drilling mud to the water body being crossed during drilling operations. Where such conditions exist, proper precautions must be taken to prevent such discharges. HDD operations should include an inadvertent return response plan. The site should also have the necessary materials and equipment readily available to quickly respond in the event of an inadvertent return which may include isolating the area and pump bypassing the stream. The methods used to accomplish this are beyond the scope of this manual but are recognized in the HDD industry.

If horizontal directional drilling is not a viable option in any watershed, the following guidance should be followed. Minor streams, those less than or equal to 10 feet wide at normal flow depth, swales, ditches, channels, and waterways should be flumed, as described in Standard Construction Detail #13-1, or pumped, as shown in Standard Construction Detail #13-2, past the open trench at the time the crossing is made. Major stream channels may be flumed or pumped where feasible. However, it is often more practical to use a cofferdam, as shown in Standard Construction Detail # 13-3, to affect the crossing, especially for utility lines with jointed assembly. For welded steel pipe installations, the preferred method is directional drilling, or boring. However, open trench installations may be approved on a case-by-case basis.

If there is an existing base flow or runoff at the time of the trenching, this flow should be flumed or otherwise diverted (e.g. pump around or coffer dam) around the work area to the existing channel below. Where stream flow is flumed, the flume shall be installed prior to trench excavation at that location. The flume should be of sufficient size to convey normal stream flow over the open trench. Sandbags may be used to direct flow into the flume. If no base flow or runoff exists, the flume may be installed immediately following backfilling of the trench. In cases where the utility line is completed — from initial disturbance to final stabilization — within one day, no flume is required for water courses with no base flow at the time of the crossing. The disturbed waterway shall be re-established and stabilized as part of the final stabilization. Note: Drainage swales should be blanketed as part of the stabilization process.

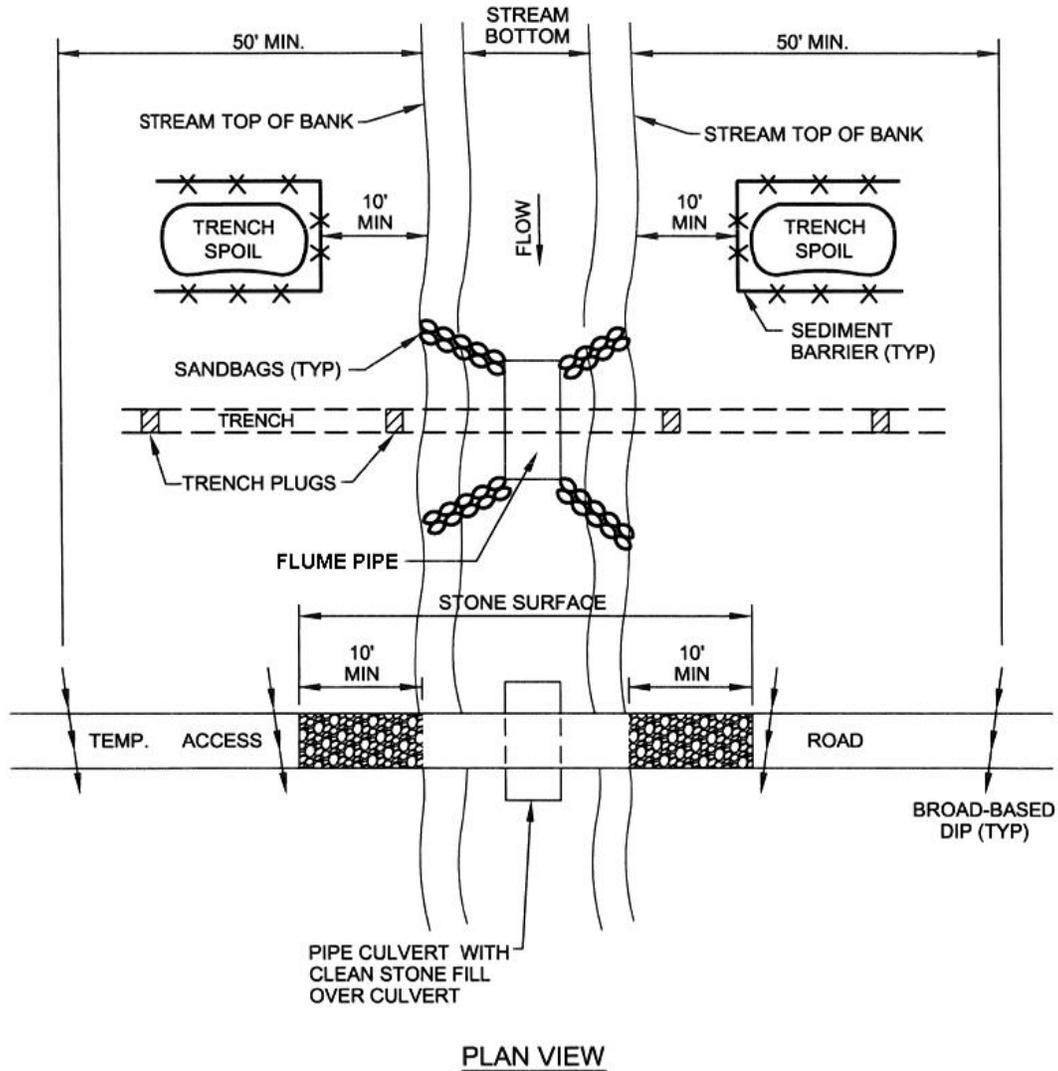
A utility line crossing of a stream channel 10 feet in bottom width or less should be completed within 24 hours from start to finish, including the trench backfilling, stabilization of stream banks and stabilization of the area 50 feet back from the top of each stream bank. Stream channels between 10 and 100 feet in width should be completed within 48 hours or as approved in writing from the Department.

Facilities for removing sediment from pumped water should be available at the stream-crossing site before trenching commences and maintained until trench backfilling is completed. Assembly areas, temporary equipment and non-hazardous material storage areas should be located at least 50 feet back from the top of stream bank.

### **Preserving groundwater hydrology**

Projects with utility lines, including stormwater, often involve piping alignments along a stream corridor to avoid or minimize direct impacts to a stream, wetland or riparian zone. Maintaining the natural mechanisms for groundwater movement in these areas is often very important for sustaining baseflow to receiving streams and for preserving riparian vegetation. In order to avoid creating a preferential pathway for groundwater flow (i.e. "French Drain" effect within the utility trench backfill - usually permeable aggregate), the use of trench plugs at a maximum spacing of 1,000 feet is warranted. Properly installed trench plugs will block the flow of groundwater along the path of the utility pipe/trench and maintain the natural groundwater path.

**STANDARD CONSTRUCTION DETAIL #13-1**  
**Typical Utility Line Flumed Stream Crossing with Optional Access Road**



PA DEP

Grubbing shall not take place within 50 feet of top-of-bank until all materials required to complete crossing are on site and pipe is ready for installation.

Pipe culvert for access road and flume pipe may be one continuous pipe.

Trench plugs shall be installed within the trench on both sides of the stream channel (Standard Construction Detail #13-4).

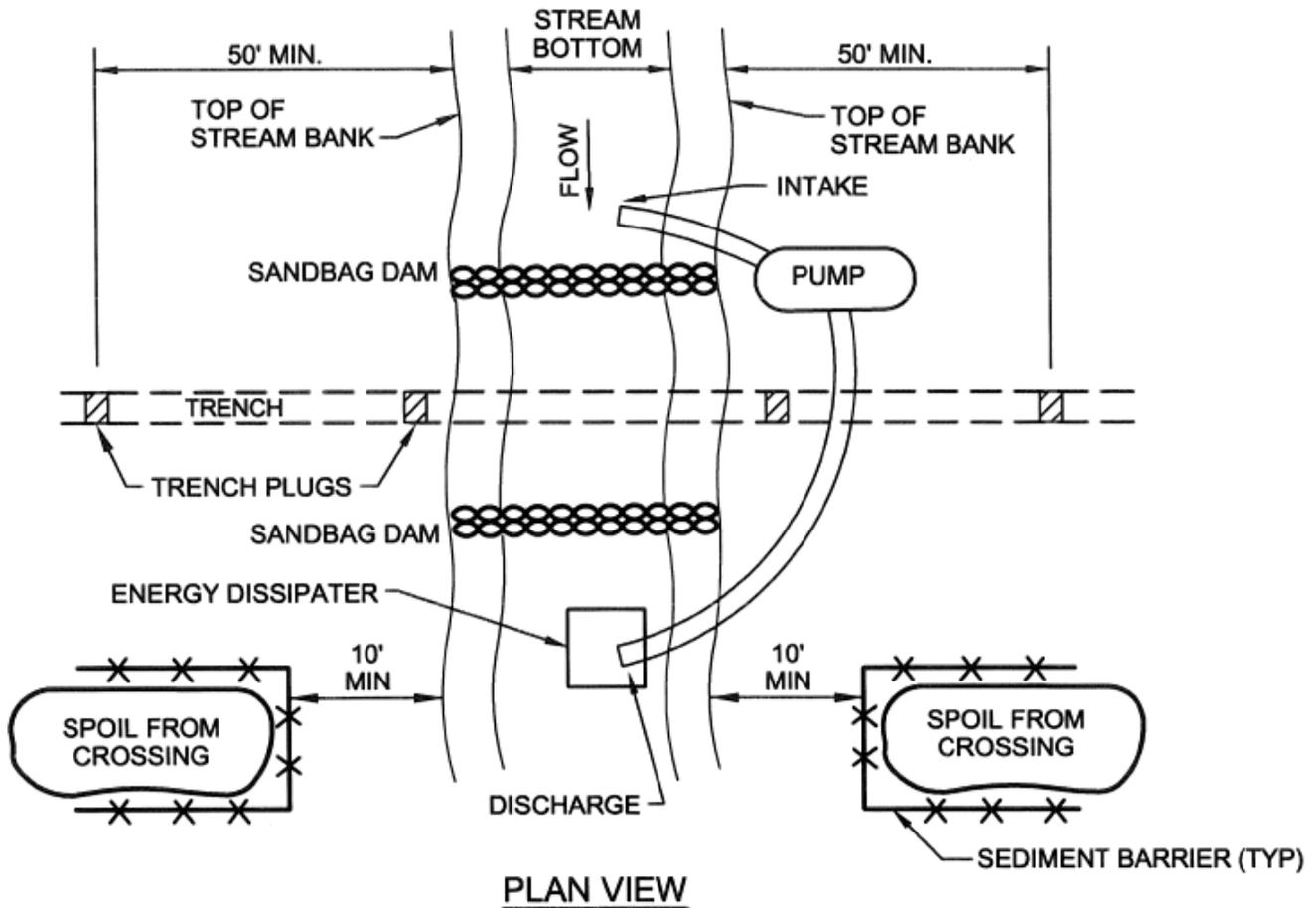
Water accumulating within the work area shall be pumped to a pumped water filter bag or sediment trap prior to discharging into any surface water.

Hazardous or pollutant material storage areas shall be located at least 100 feet back from the top of streambank.

All excess excavated material shall be immediately removed from the stream crossing area.

All disturbed areas within 50 feet of top-of-bank shall be blanketed or matted within 24 hours of initial disturbance for minor streams or 48 hours of initial disturbance for major streams unless otherwise authorized. Appropriate streambank protection shall be provided within the channel.

**STANDARD CONSTRUCTION DETAIL #13-2  
Typical Utility Line Stream Crossing with Pump Bypass**



PA DEP

Grubbing shall not take place within 50 feet of top-of-bank until all materials required to complete crossing are on site and pipe is ready for installation.

Bypass pump intake shall be maintained a sufficient distance from the bottom to prevent pumping of channel bottom materials.

Trench plugs shall be installed within the trench on both sides of the stream channel (Standard Construction Detail #13-4).

Water accumulating within the work area shall be pumped to a pumped water filter bag or sediment trap prior to discharging into any receiving surface water.

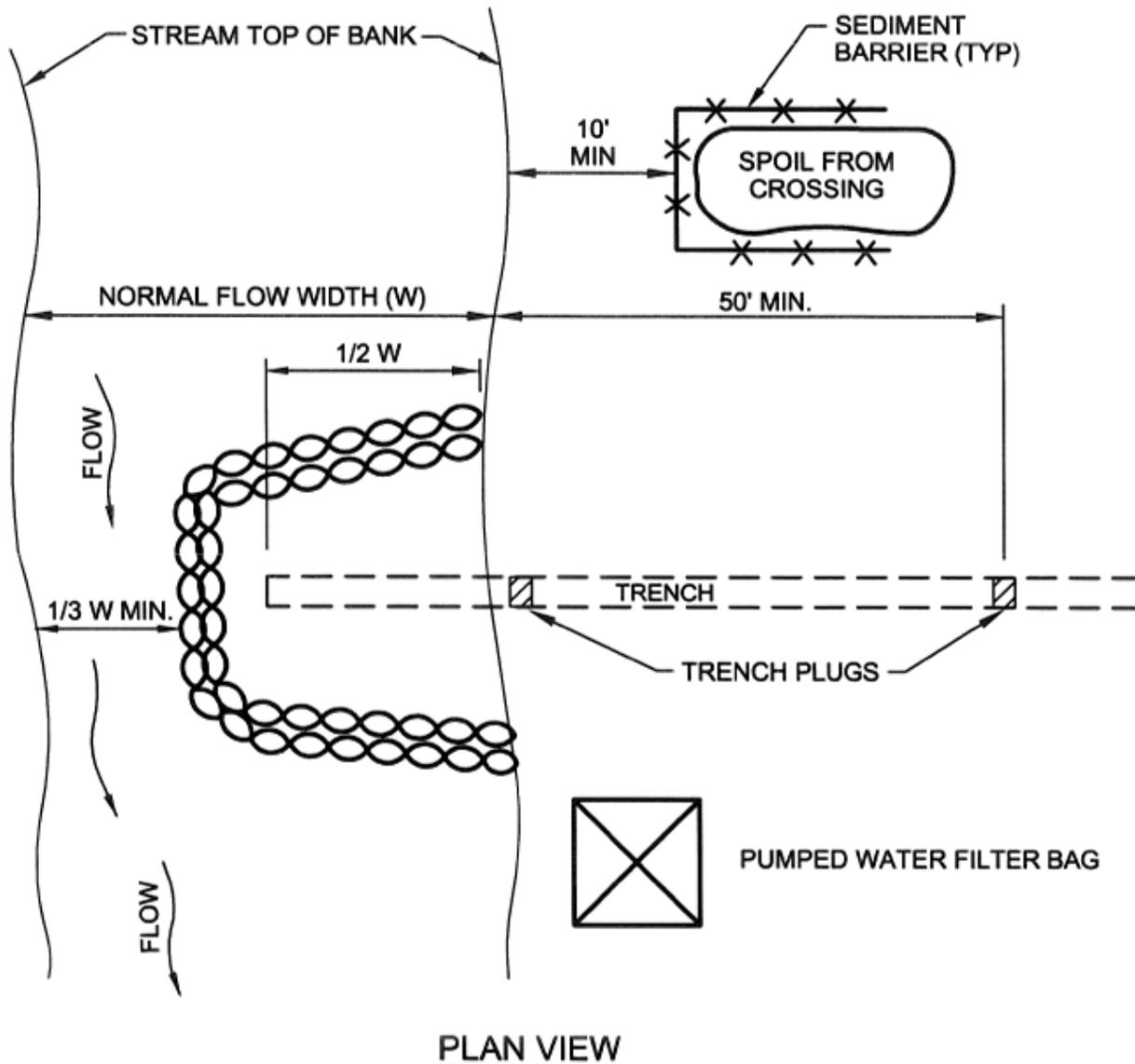
Hazardous or pollutant material storage areas shall be located at least 100 feet back from the top of streambank.

All excess excavated material shall be immediately removed from the stream crossing area.

All disturbed areas within 50 feet of top-of-bank shall be blanketed or matted within 24 hours of initial disturbance for minor streams or 48 hours of initial disturbance for major streams unless otherwise authorized.

Appropriate streambank protection shall be provided within the channel.

**STANDARD CONSTRUCTION DETAIL #13-3  
Typical Utility Line Stream Crossing with Cofferdam**



PA DEP

Grubbing shall not take place within 50 feet of top-of-bank until all materials required to complete crossing are on site and pipe is ready for installation.

Trench plugs shall be installed within the trench on both sides of the stream channel (Standard Construction Detail #13-4).

Water accumulating within the work area shall be pumped to a pumped water filter bag or sediment trap prior to discharging into any receiving surface water.

Hazardous or pollutant material storage areas shall be located at least 100 feet back from the top of streambank.

All excess excavated material shall be immediately removed from the stream crossing area.

All disturbed areas within 50 feet of top-of-bank shall be blanketed or matted within 24 hours of initial disturbance for minor streams or 48 hours of initial disturbance for major streams unless otherwise authorized.

**Appropriate streambank protection shall be provided within the channel.**

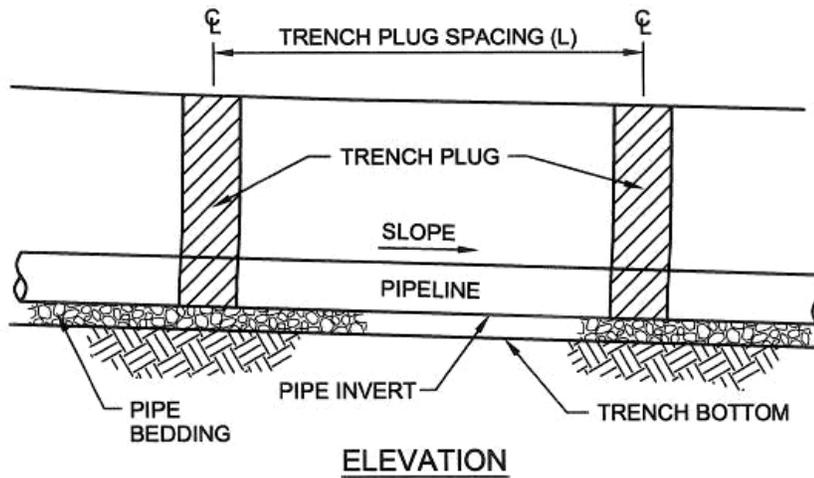
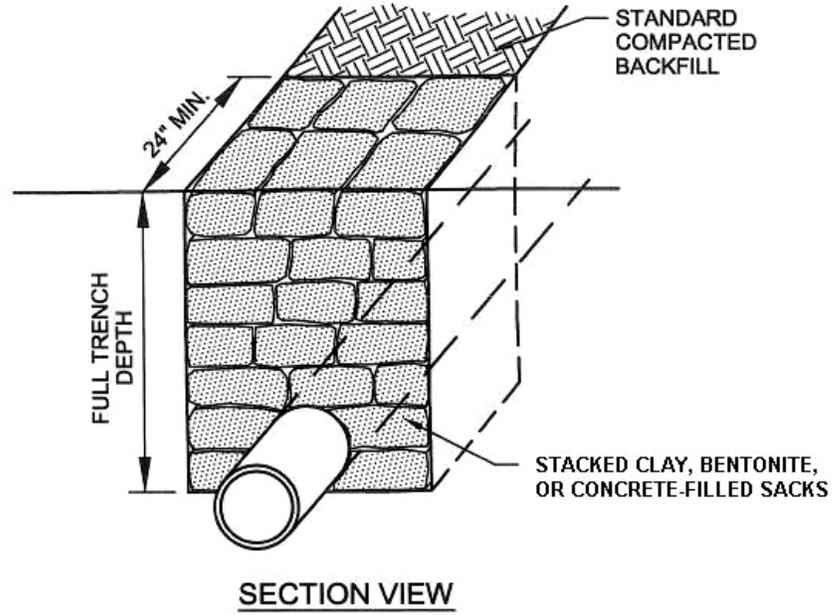
**WETLAND CROSSINGS** Wherever soils that have major hydric components or have hydric inclusions are present on, or adjacent to, an existing or proposed right-of-way, a determination should be conducted to determine if wetlands that could be affected by the proposed earthwork exist on or near the project site. Where such wetlands exist, they are to be delineated and shown on the plan map(s). Wetland crossings must be avoided wherever possible. Where avoidance is not possible, the alignment must be such that the smallest possible disturbance is made. All appropriate permits/authorizations must be obtained prior to crossing wetlands.

Staging areas should be located at least 50 feet from the edge of the wetland. Wherever wetland crossings can be affected by boring, that is the preferred method. This method may be considered an ABACT in special protection watersheds. If boring is not a viable option in any watershed, the following guidance should be followed. Movement of vehicles across the wetland must be minimized. Where vehicles need to cross wetlands, the use of temporary pads or mats, as shown in Figures 3.5, 3.6 and 3.7, shall be used due to the potential for rutting. Excavated topsoil with the vegetative root mass shall be carefully removed and stockpiled separately from the subsoil, unless there is standing water or the soil is too saturated to segregate. BMPs, including trench plugs, shall be installed to prevent the trench from draining the wetlands or changing its hydrology. Lime and fertilizer are not to be applied to the backfilled trench. Annual ryegrass may be applied at the rate of 40 lb/acre where needed to areas without standing water. Straw mulch should be used at the rate of 3 T/acre and without binding agents.



Lycoming County Conservation District

**STANDARD CONSTRUCTION DETAIL # 13-4  
Typical Trench Plug Installation**



PA DEP

**TABLE 13.1  
Maximum Spacing and Materials for Trench Plugs**

Trench Slope (%)	Spacing L (FT)	Plug Material
< 5	1,000	* Clay, Bentonite, or Concrete Filled Sacks
5 - 15	500	* Clay, Bentonite, or Concrete Filled Sacks
15 - 25	300	* Clay, Bentonite, or Concrete Filled Sacks
25 - 35	200	* Clay, Bentonite, or Concrete Filled Sacks
35 - 100	100	* Clay, Bentonite, or Concrete Filled Sacks
> 100	50	Cement Filled Bags (Wetted) or Mortared Stone

**\*TOPSOIL MAY NOT BE USED TO FILL SACKS.**

**Impervious trench plugs are required for all stream, river, wetland, or other water body crossings.**

## WATERBARS

Waterbars, including slope breakers and interceptor dikes, should be installed across the entire right-of-way on all slopes.



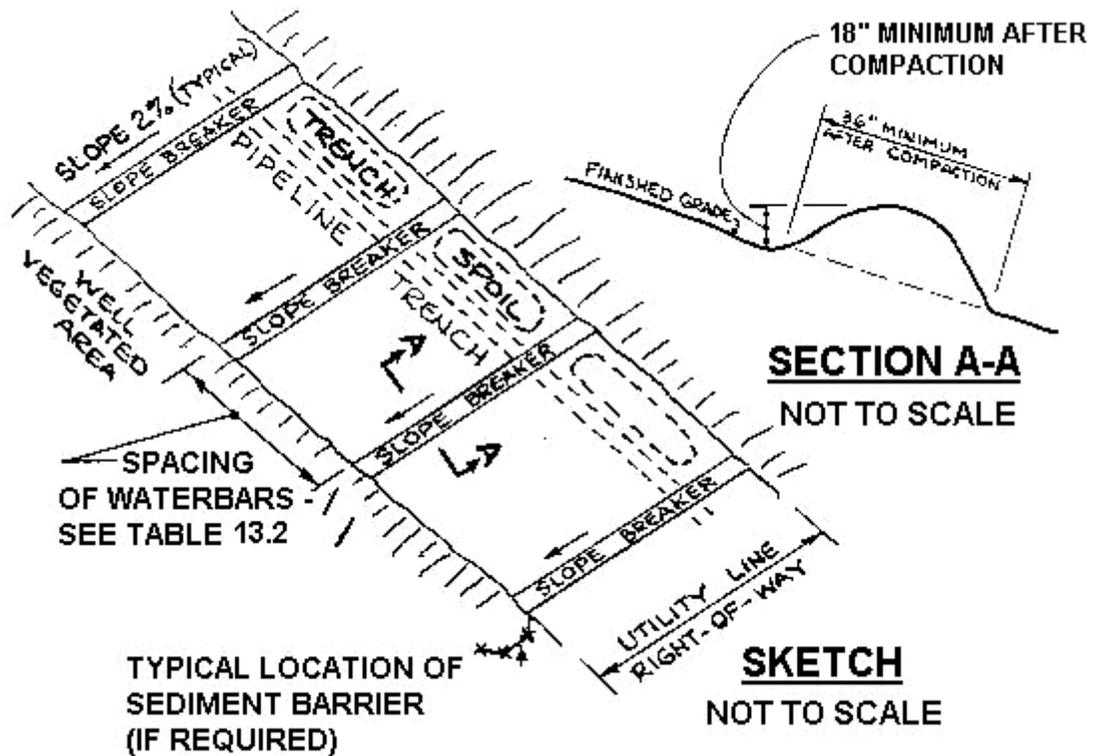
PA DEP

Waterbars should be constructed at a slope of 2% and discharge to a well-vegetated area on the downslope side of the right-of-way. This may include wooded areas if the recommended spacing provided in Table 13.2 is followed. Waterbars should not discharge into an open trench. Obstructions, such as straw bales, silt fence, rock filters, compost socks etc. should not be placed in any waterbars. Where needed, they may be located below the discharge end of the waterbar.

Waterbars need not be installed on residential lawns or in agricultural fields.



**FIGURE 13.1**  
**Waterbar Installation on a Utility Line Right-of-way**



PA DEP

**TABLE 13.2**  
**Maximum Spacing for Permanent Waterbars on a Utility Line Right-of-way**

Percent Slope	Spacing (FT)
< 5	250
5 - 15	150
15 - 30	100
> 30	50

Permanent waterbars are required at all stream, river, and other water-body crossings as well as upslope from roadway and railroad cut slopes.

## CHAPTER 14 - TIMBER HARVESTING



Timber harvesting involves cutting trees for sale. It may be done as part of the initial clearing and grubbing process for future development or independent of any future activity on the site. Although timber harvesting is exempted from the necessity of obtaining an NPDES construction permit, removal of trees, even if those trees are subsequently sold, in preparation for future development is not exempt. Timber harvesting projects not done as preparation for future development that disturb 25 acres or more, including the sum of all haul roads, skid trails, landing areas, etc. are required to obtain an Erosion and Sediment Control Permit (ESCP) prior to beginning the

harvest. In either case, the BMPs are very similar in the initial stages. The difference is that BMPs approved for the future development should be under construction as clearing progresses, while a site that is simply undergoing a timber harvest will typically not have sediment basins, traps, storm sewer inlets, etc. The Department's Timber Harvesting Packet is recommended for development and submittal of E&S plans for timber harvesting.

Since access is as important to timber harvesting as it is to development, the BMPs described in Chapters 3 and 4 are recommended for use on timber harvest sites.

The principal areas of disturbance associated with a timber harvest are the haul roads, skid trails, and landing areas.

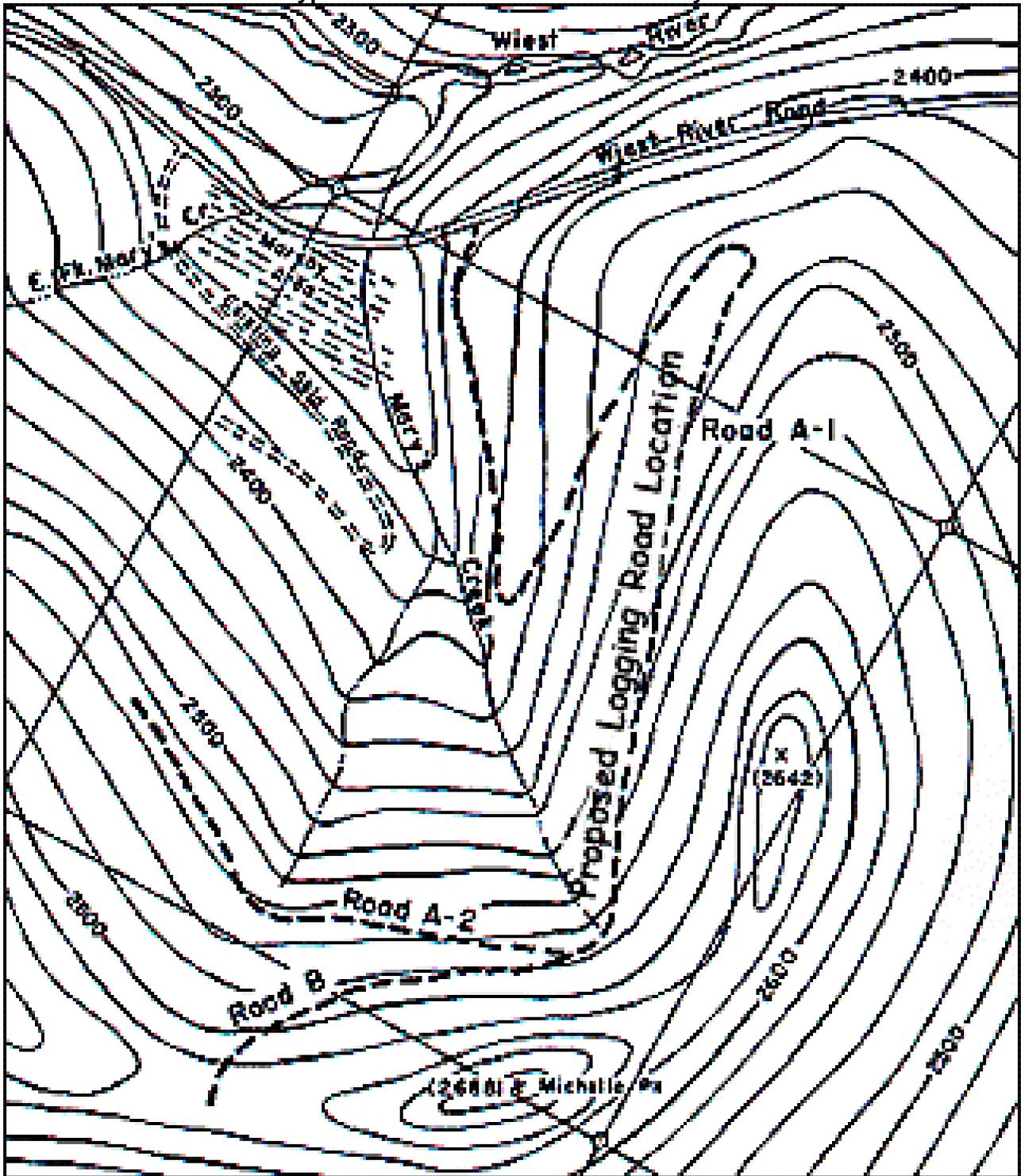
### HAUL ROADS

Haul roads for a timber harvest project typically run from the landings to the entrance(s). Every road system should be planned and developed as if it will be permanent. Many roads are initially considered to be temporary, but often these temporary roads are used again and again. Therefore, the entire road system should be designed before any road construction begins. This process may seem to take more time, but a well-planned road system will be more efficient, less costly, and easier to maintain.

The following points should be considered when laying out a road system:

1. **Construct only as much road as necessary.** Minimize clearing. Keep road width to the minimum necessary for safe and efficient operation.
2. **Terminal Points** - Locate the start and end of the road system using the best access that is safe and visible from public roads. Locate landings away from streams and wet areas. Install stabilized entrances, as shown in Standard Construction Detail # 3-1, at all exit points onto a public roadway. Install an entry gate or barricade to keep potentially damaging and unwanted traffic off the haul road. **NOTE: A highway occupancy permit may be required.**
3. **Grades** - Roads with a maximum slope of 10 percent and a minimum of 2 percent are usually the easiest to maintain. Where absolutely necessary, grades of 15 to 20 percent can be used for short distances. Follow the contour as much as possible.
4. **Topography** - Roads on moderate side hills are easiest to build and maintain. Avoid steep slopes wherever possible.
5. **Drainage** - Construct roads to drain at all times, such as using crowned or insloped surfaces. Install ditch relief culverts at specified intervals, as shown in Table 3.3 or 3.4. Provide outlet protection at all culvert outfalls. Turnouts, as shown in Figure 3.3, may be used on low-side ditches to direct flow into vegetative filter areas.
6. **Grading** - Minimize cut and fill work, and keep slopes at stable angles. Remove trees from tops of cuts, and seed and mulch cut and fill slopes promptly. Do not place fill into open sinkholes, waterways, wetlands, floodways, or other sensitive areas.
7. **Obstacles** - Design the road system to go around springs, seeps, wetlands, poor drainage areas, ledges, and rocky areas wherever possible.
8. **Soils** - Be aware of soil texture, drainage class, and slope position as outlined in Appendix E. Some soils are poorly drained or seasonally wet and are difficult to log. Others are unstable when support is removed to make a road cut or when used as fill. The NRCS soils website should be consulted to identify soil limitations. Minimize the traffic areas. Running equipment over soil compacts it and damages its ability to infiltrate runoff.
9. **Distances from Streams** - Buffer areas should be maintained along stream corridors to provide sediment filtration and maintain stream temperatures. Wherever sufficient filter strips are not possible between roadways and receiving waters, install BMPs, such as wood chip berms, silt fence, etc., as the roadway progresses. See Table 14.1 for minimum filter strip widths.
10. **Stream Crossings** - Minimize the number of stream crossings. Cross at a 90 degree angle and approach the stream at as gentle a slope as possible. Consider all stream crossings temporary. Only bridge crossings, as shown in Figure 3.5, or culvert type crossings, as shown in Standard Construction Details 3-11, 3-12 and 3-13, may be used. Ford crossings are not acceptable. **NOTE: An encroachment permit or Army Corps of Engineers (ACOE) permit will be required.**
11. **Old roads** - It is often possible to use existing roads and thereby lessen the soil disturbance. However, to avoid problems, carefully evaluate the road's suitability for upgrading.
12. **Size and duration of sale** and the anticipated season of harvest.
13. **Floodways and wetlands** - Avoid encroaching on wetlands. Roadway construction within floodways — typically 50 feet from top of streambank — and wetlands require encroachment permits.
14. **Water control structures** - Carefully plan the use of broad-based dips, waterbars, culverts, and ditches to maintain existing flow patterns and minimize the amount of runoff being conveyed by roadways and roadside ditches. Figure 14.1 shows a typical haul road layout.

FIGURE 14.1  
Typical Timber Harvest Haul Road Layout



Source Unknown

## SKID ROADS AND SKID TRAILS

The primary difference between a skid road and a skid trail is the degree of preparation for use. Main skid roads should be flagged, cleared, and graded. Skid trails, which are used for transporting logs from stump to main skid road, are usually not graded and need only minimal clearing. In developing a skid road and trail system, pay special attention to proper drainage and soil stabilization. The following items should be considered:



Source Unknown

1. **Landings** - Locate landings in relation to the main haul road. Then lay out the skid road and trail approaches on a low grade to the landings.
2. **Grades** - Keep grades as low as the topography will permit. Do not go straight up the slope; proceed across the slope as much as possible. Grades of 20% or more should be avoided. Where unavoidable, they should be kept to short distances and make use of waterbars.
3. **Avoid Streams, Wetlands, Rocky Slopes, and Steep Grades.** Skid trails and skid roads should be located at least 50 feet from stream channels and wetlands wherever possible.
4. **Stream Crossings** - Use temporary bridges or culverts and obtain all appropriate permits/authorizations.
5. **Use Waterbars** wherever it is not possible to avoid going straight up or down slopes.
6. **NEVER SKID THROUGH OR ACROSS STREAM CHANNELS, WETLANDS, SPRINGS, OR SEEPS.**

## LOG LANDINGS

The number and size of landings should be kept to the minimum necessary to operate safely and efficiently.



Source Unknown

Few erosion problems are associated with a properly located landing. Problems will occur, however, when water control is not considered in selecting a location. Only sites that will hold up under the anticipated use by heavy equipment should be chosen. Avoid sensitive areas such as riparian management zones, waterways, wetlands, caves, springs, seeps, and open sinkholes. Allow adequate undisturbed buffer strips between the landing and streams or sensitive areas, as shown in Table 14.1.

**TABLE 14.1**  
**Minimum Vegetative Filter Strip Widths for Timber Harvesting**

Land Slope (%)	Minimum Filter Strip Width (ft.)	
	Meadow	Forest*
< 10	50	75
20	65	100
30	85	125
40	105	160
50	125	190
60	145	220
70	165	250

\*A sediment barrier (e.g. wood chip berm, silt fence, straw bales, etc.) should be placed immediately below the disturbed area due to minimal sediment removal on typical forest floors.

Disturb only the area needed for safe operations. If the topography warrants, use a diversion channel, as described in Chapter 6, above the landing to keep upslope runoff from entering the landing area.

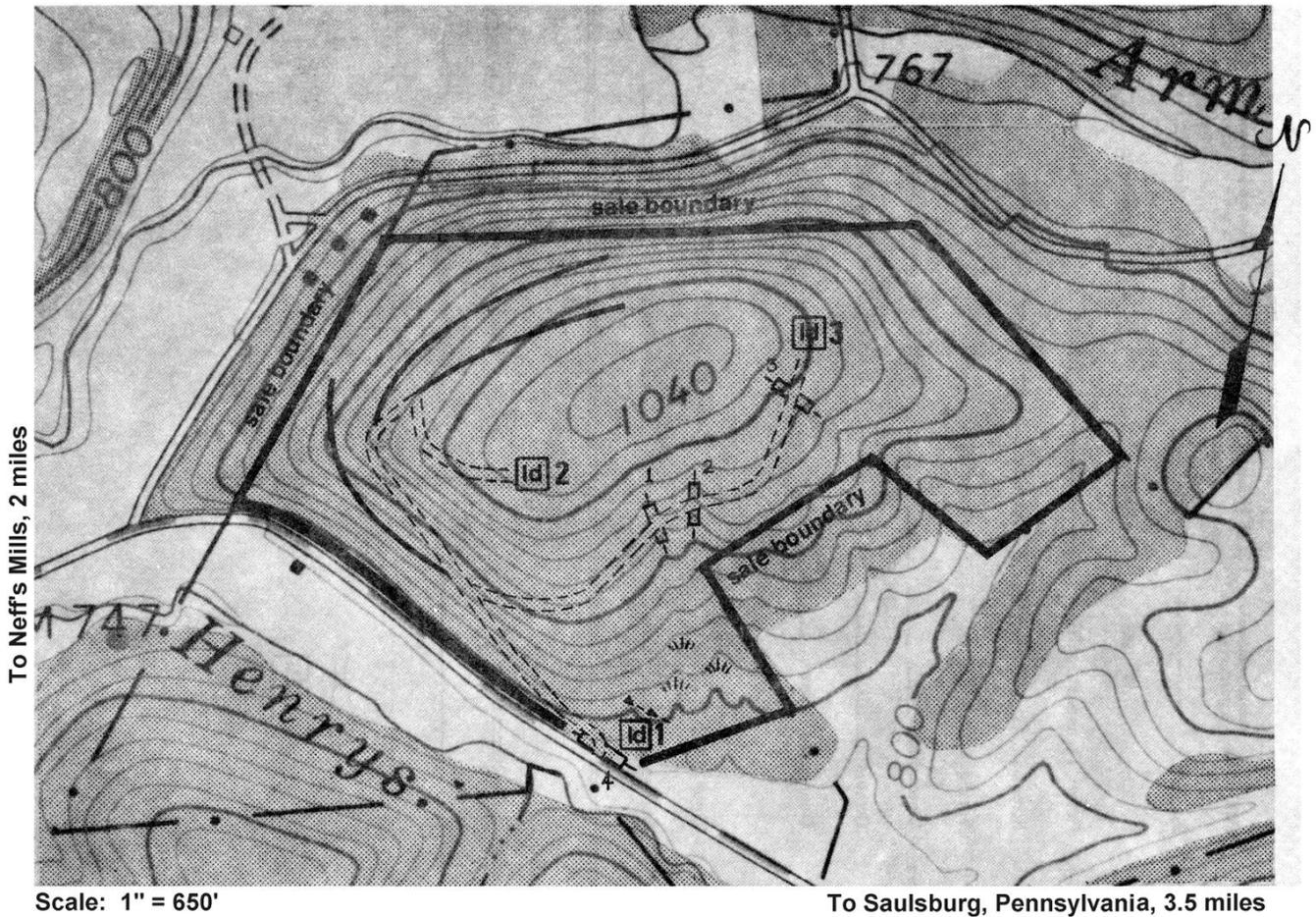
The diversion channel should have a suitable protective liner and outlet to an existing waterway wherever possible. If no waterway exists, the discharge should be directed to a stable area. If leveling is necessary, cut and fill should not alter the natural drainage pattern of the area.

Heavy equipment quickly compacts soils on landings, preventing water from infiltrating. Therefore, the landing should be sloped so as to direct runoff to a sediment removal BMP such as a wood chip berm, silt fence, straw bales, etc.

Skid roads, skid trails, and haul roads approaching the landing from above should have a waterbar, broad-based dip, or other means of diverting flow into a stable area before it reaches the landing.

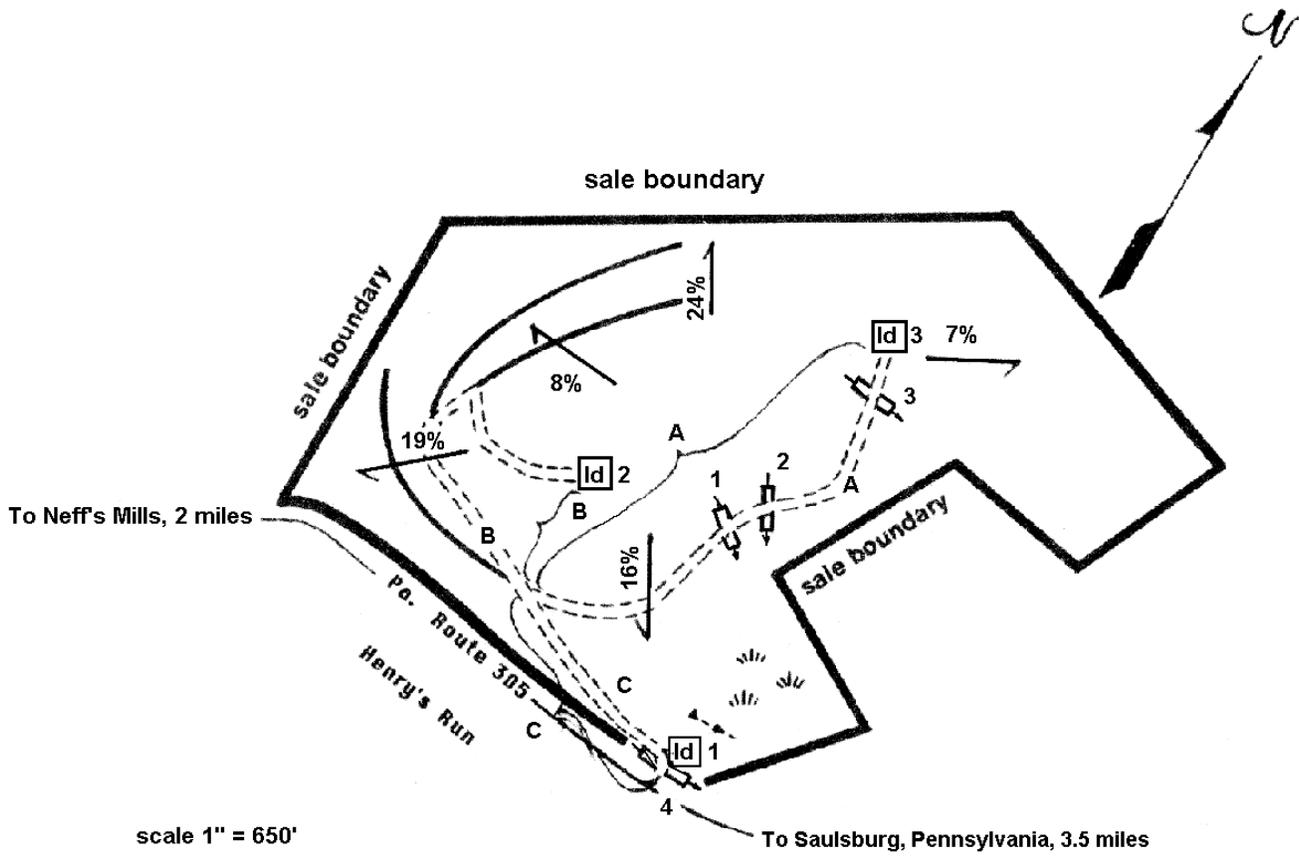
Figure 14.2 is an example of a typical timber harvest site plan and Figure 14.3 is an alternative timber harvest site plan. If a legible photocopy of a USGS topographic quad map is submitted as a location map for the E&S plan, as specified in the Timber Harvesters Action Packet, the contours need not be duplicated on the site plan.

**FIGURE 14.2**  
**Typical Timber Harvest Site Plan**



PA Timber Harvest Packet

**FIGURE 14.3**  
**Alternative Timber Harvest Site Plan**



Adapted from PA Timber Harvest Packet

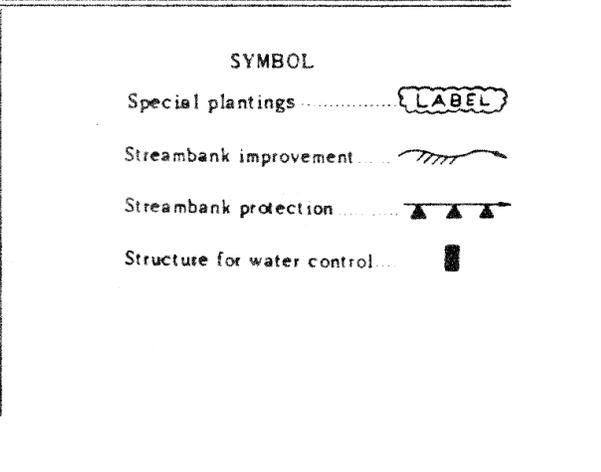
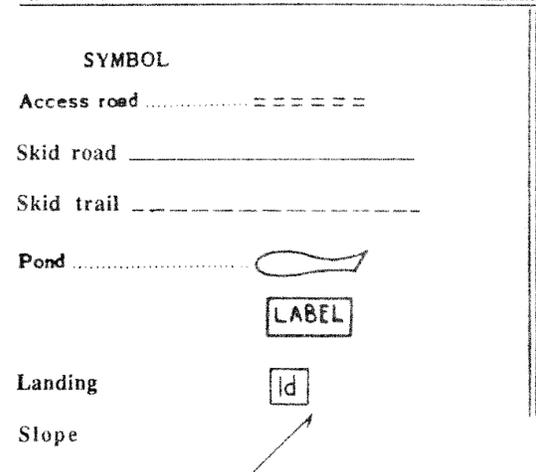
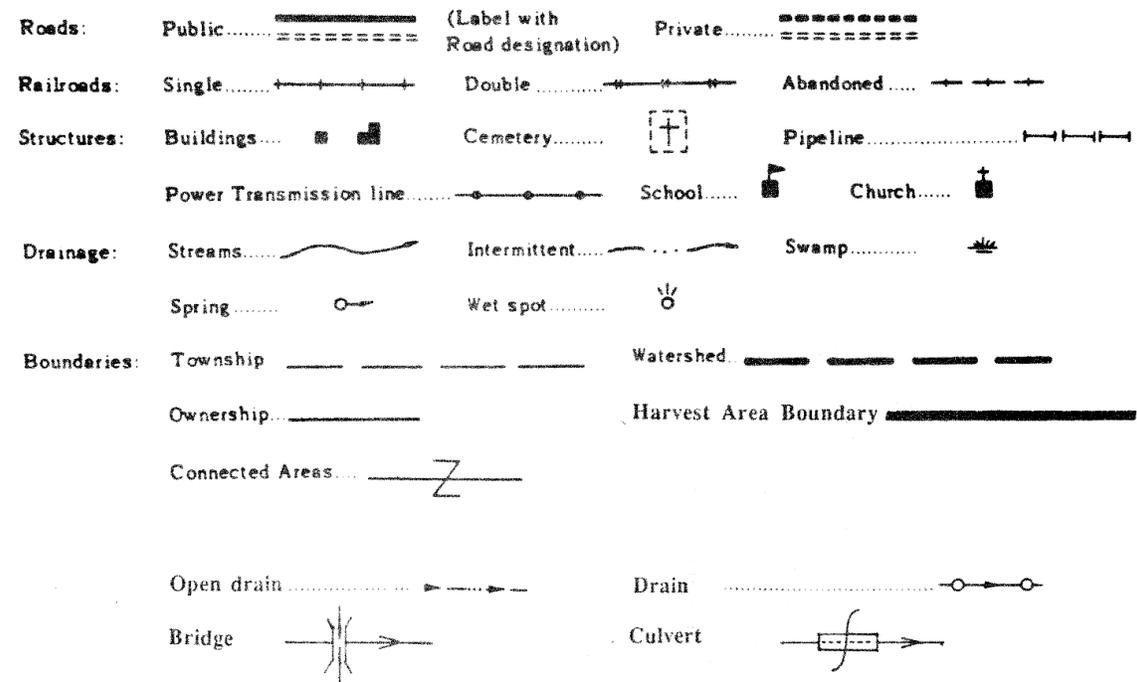
WINTER HARVESTS

Timber harvests are often conducted during the winter months to take advantage of frozen ground. While this practice is encouraged, there are a few concerns that should be addressed:

1. Before it snows, mark existing culverts and other drainage structures as well as waterways and wetlands, which can be obscured by snowfall. Keep all drainage structures open and functioning properly.
2. Wherever haul roads and skid roads are constructed over soils with low strength, as identified in Appendix E, hauling and skidding should be limited to periods when temperatures are below freezing unless these roads have been engineered to withstand the equipment weights involved.
3. During cold weather, snow should be plowed from haul roads and skid roads to facilitate freezing of the road grade before hauling.
4. Operations should be suspended during thaw cycles, winter rains, and during times of heavy snow melt when soils tend to be saturated.
5. During times of heavy snow, provide breaks in snow berms along plowed roads to facilitate drainage.
6. Compact skid trail snow before skidding logs. This will help protect soils that are not completely frozen.



**FIGURE 14.4**  
**Typical Timber Harvest Plan Mapping Symbols**



PA Timber Harvesting Packet

## RETIREMENT OF HAUL ROADS, SKID ROADS, SKID TRAILS, AND LANDINGS

When a tract or parcel within a harvest area has been completed, all haul roads, skid trails, and landings associated with that tract or parcel should be retired; even while timbering continues on other tracts and parcels. To do so, the following guidelines are recommended:

1. Regrade all road and landing surfaces to approximate original contour. Scarify compacted soils in preparation for seeding.
2. Remove ditch relief culverts and replace them with waterbars or broad-based dips.
3. Remove all temporary stream and wetland crossings and stabilize disturbed areas. Install or restore waterbars at appropriate distances on the approaches to the stream crossings.
4. Seed and mulch disturbed areas with seed mixtures appropriate for site conditions, such as shade tolerant, steep slope mixture, acid tolerant, etc. and further identified in Tables 11.3, 11.4 and 11.5. Blanket disturbed areas within 50 feet of stream channels or wetlands.



Armstrong Conservation District

## CHAPTER 15 - STREAMBANK STABILIZATION

Upon completion of work within a stream channel, disturbed areas must be stabilized to prevent erosion before diverted flows are redirected into the disturbed area of the channel. The type of stabilization to be used depends upon the size of the stream channel, its flow conditions, soils, and considerations for migration of aquatic life. The form of bank protection should mimic the natural conditions as much as possible, while providing sufficient protection for the anticipated flows from the design storm events. There are many products and methods available to the designer. This chapter addresses some of the most commonly used methods. These methods are also useful for lake shore restoration. Other methods, unless specifically ruled out, will be considered on a case-by-case basis. For additional information on the proper selection, design, and installation of streambank protection, the Department recommends searching for “streambank protection” on the NRCS website <http://directives.sc.egov.usda.gov>.



Source Unknown

Bank stabilization projects are often located on the outside banks of meanders. In such cases, it is usually necessary to extend the protection a certain distance upstream and downstream of the affected areas to prevent future scour. The minimum distances that the protection should be extended are shown in Figure 15.2. Upstream and downstream ends must be keyed into the bank per General Permit 3. Consideration should also be given to keying the bottom into the stream bed.

**VEGETATION** Seeding disturbed areas with a perennial grass seed mixture is a relatively inexpensive means of achieving stabilization. In many cases, heartier vegetation, such as shrubs or other woody plants, will be required to provide scour protection. The seed mixture and other vegetation chosen

should be suitable for the site conditions, such as wetness, soils, sunlight, etc. Please see Tables 11.3, 11.4 and 11.5 for recommended seed mixtures. Selection of woody plants should typically be based upon a visual survey of existing vegetation in the surrounding area. Due to the proximity to receiving waters, soil amendments are not recommended. Seeded areas should be covered with an erosion control blanket appropriate for the anticipated flow conditions. In most cases a jute or curled wood blanket should be sufficient. However, if high velocity flows are a frequent occurrence, a more substantial blanket or TRM might be needed. Only native seed mixes should be utilized within 50 feet of the stream channel.

Seeding should not be attempted below the normal flow depth of the channel. If scour protection is needed at that level, consideration should be given to using staked fiber rolls or a form of hard armor such as riprap, concrete jacks, or other products designed for such use.

RIPRAP Stream channels typically have bed slopes less than 0.10 feet/foot. Therefore, the riprap protection can be sized either by maximum velocity or shear stress. At a minimum, the stone should be sized to withstand the anticipated peak flow from a 10-year storm event. The ability to withstand flows from larger storms may be required for some streams or in certain locations.

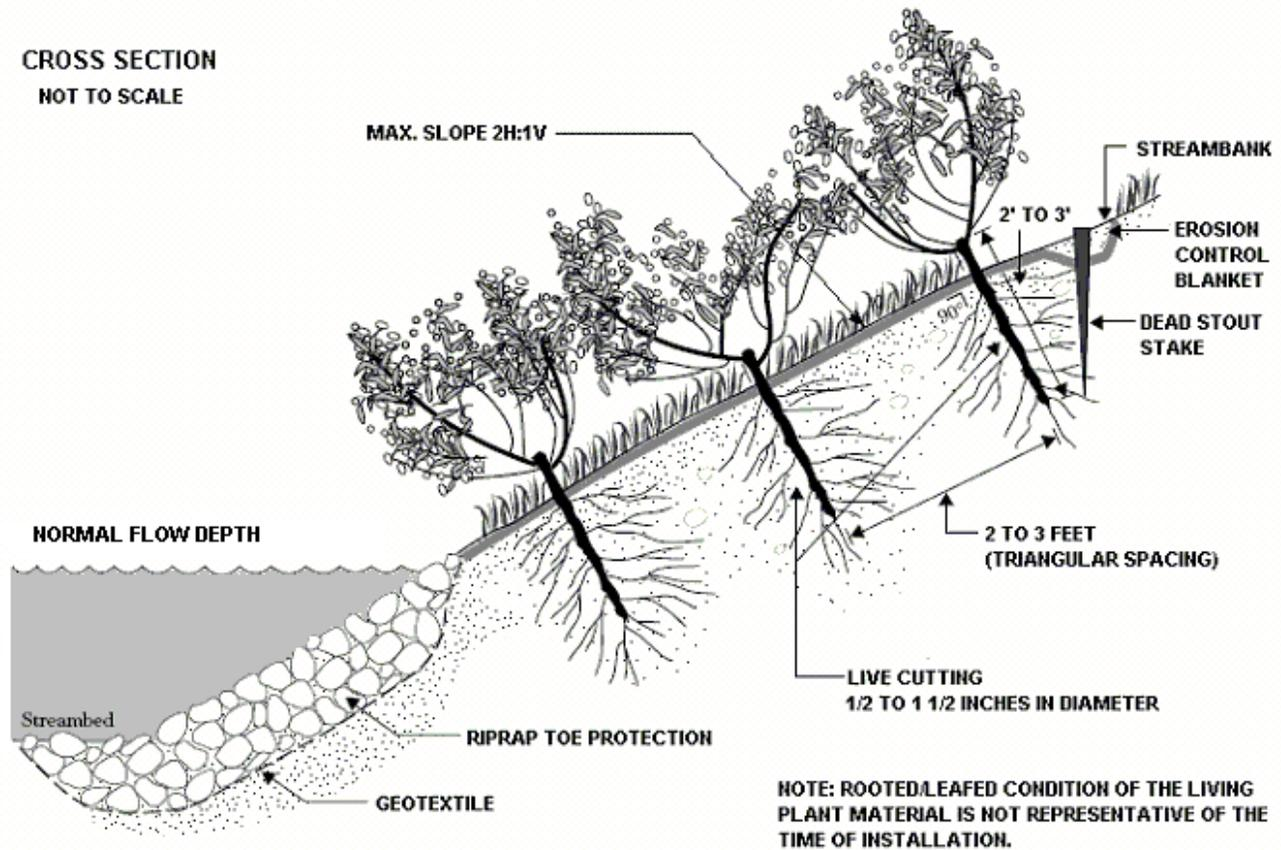


PA DEP

Where riprap is proposed for streambank protection, it should be installed as shown in Figure 15.1. The dimensions in the detail will depend upon the size of the riprap that is required. Provision should be made for passage of aquatic life through the stabilization area once the stone is in place.

In most cases, the riprap need not extend more than 12" above the normal flow depth, often evidenced by a lack of vegetation or a strand line. If additional stream bank above that elevation has been disturbed, consideration should be given to using a perennial vegetative cover.

**Figure 15.1**  
**Riprap Streambank Protection with Optional Live Stakes**

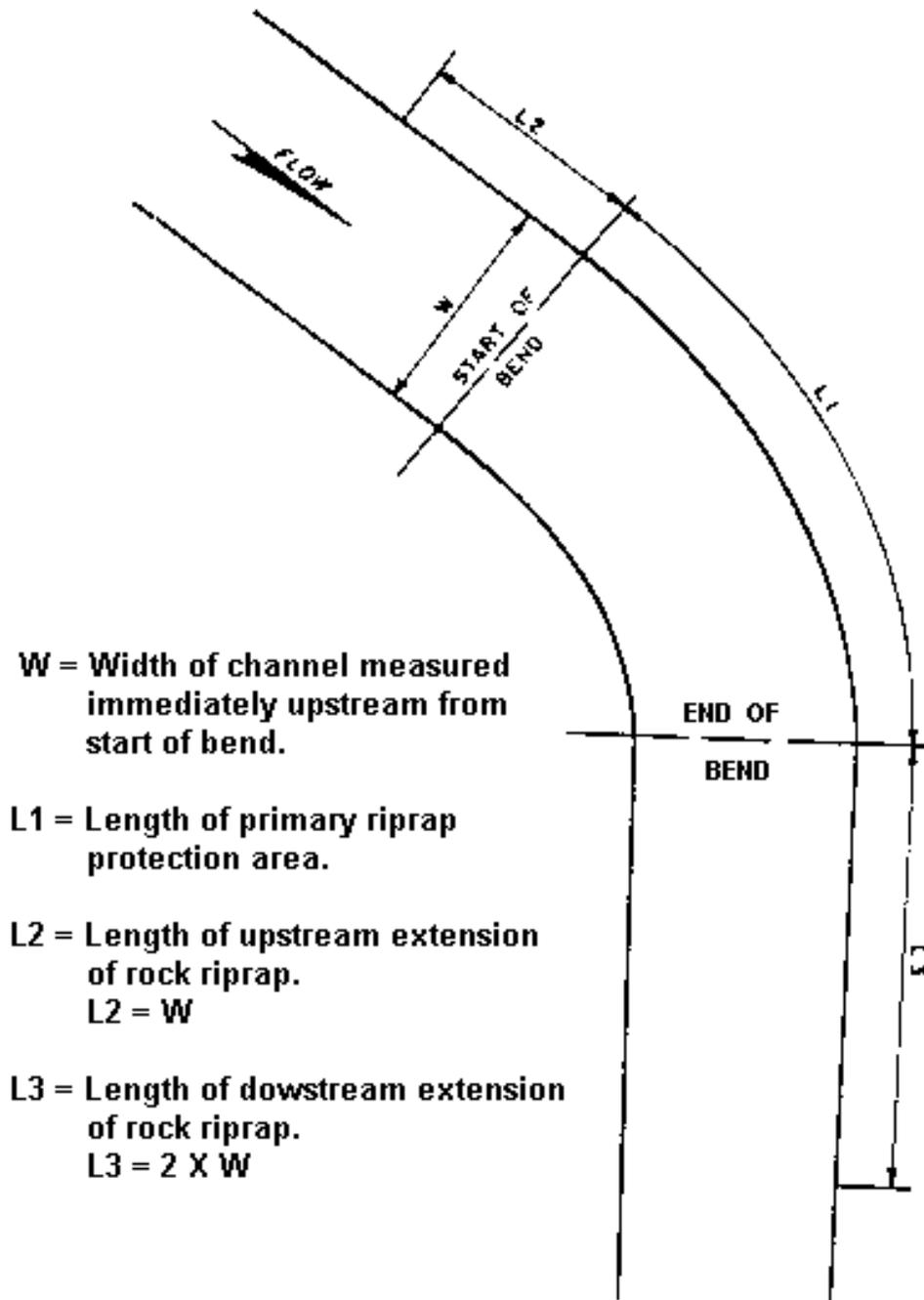


Adapted from USDA NRCS, *Engineering Field Handbook*, Chapter 16

**Filter stone, as specified in Table 6.6, may be substituted for the geotextile where site and soil conditions warrant.**

**NOTE: Extend riprap into streambed only as far as required to provide proper toe support.**

**FIGURE 15.2**  
**Extension of Primary Rock Riprap Protection Area**



PA DEP

**NOTE: Upstream and downstream ends must be keyed into the bank as per GP-3 requirements.**

GABIONS and Reno mattress have been used to stabilize stream banks for many years. Results have been mixed. While successful in many locations, gabions have failed where undermined or where the wire baskets have been damaged by abrasion or corrosion. Therefore, before specifying gabions for streambank stabilization, consideration should be given to the available substrate, pH, and anticipated sediment transport of the water. If these are not suitable, another form of stabilization should be considered.

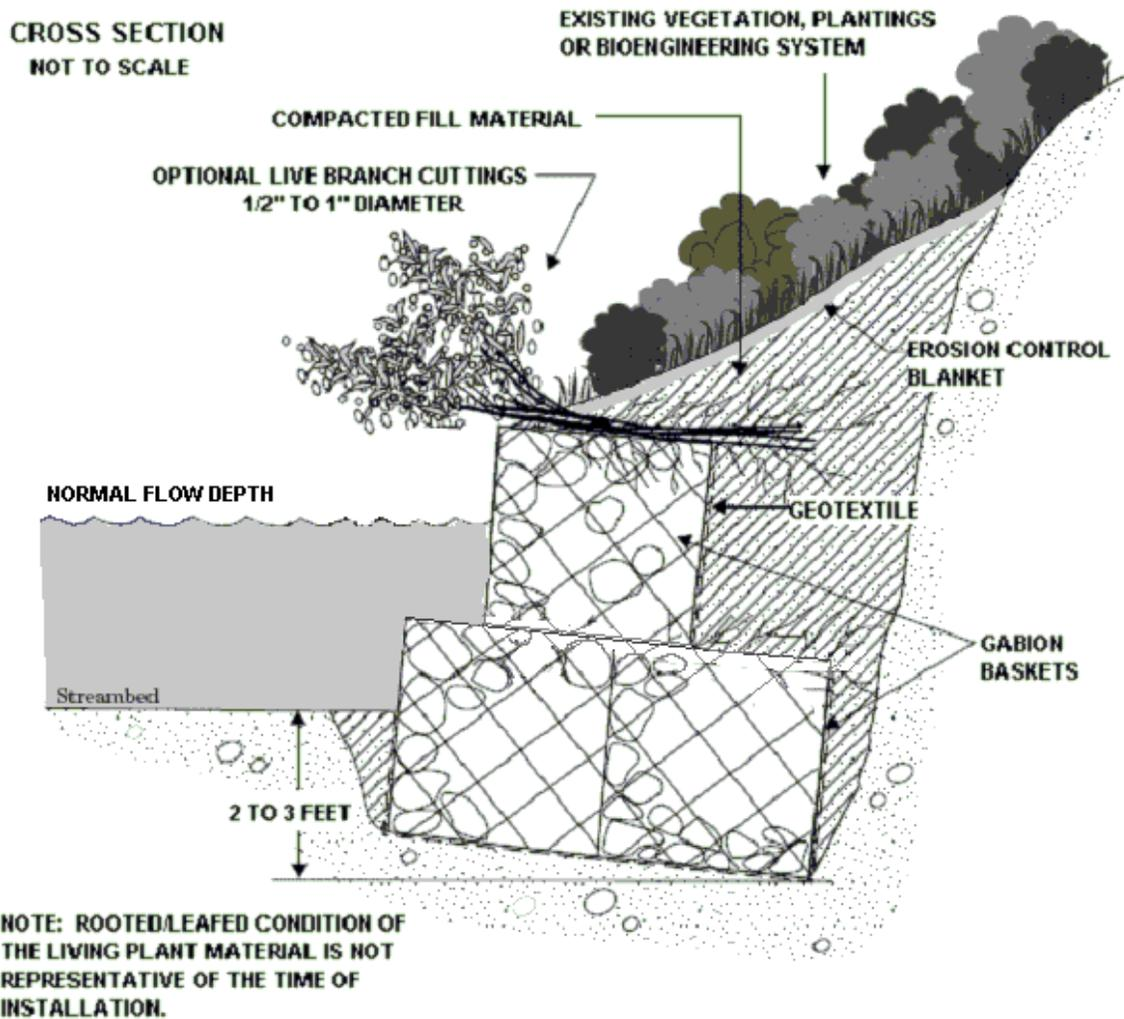


York County Conservation District

Where gabions or Reno mattresses are proposed, they are typically installed as shown in Figure 15.3 or 15.4. As with other types of stabilization, sufficient details should be provided on the detail sheets to ensure their proper installation, and supporting calculations should be included in the narrative to show they are properly sized. Gabion and Reno mattress installations should be designed according to manufacturers' specifications.

Special attention should be given to preventing scour at the upstream and downstream ends of the baskets. Appropriate means to prevent undermining should also be taken.

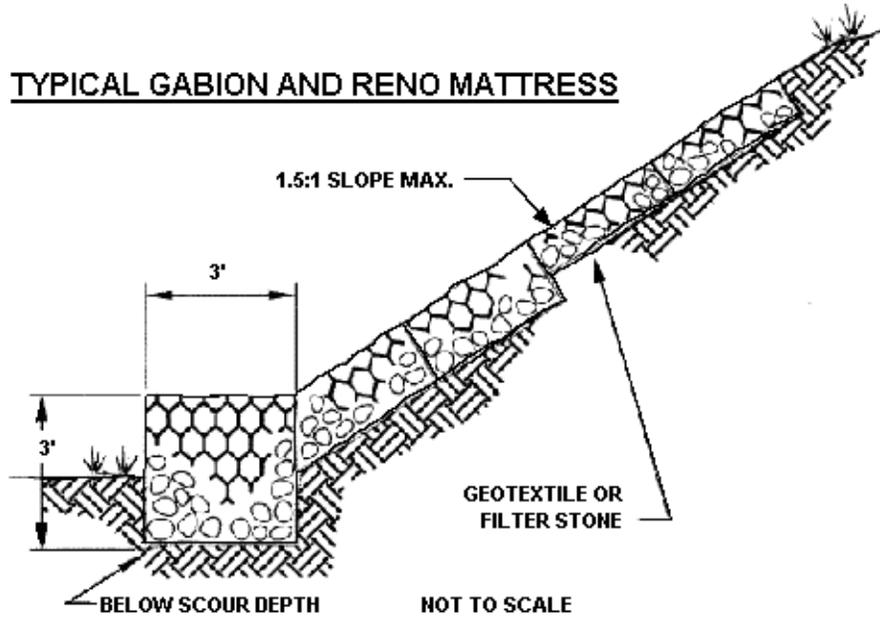
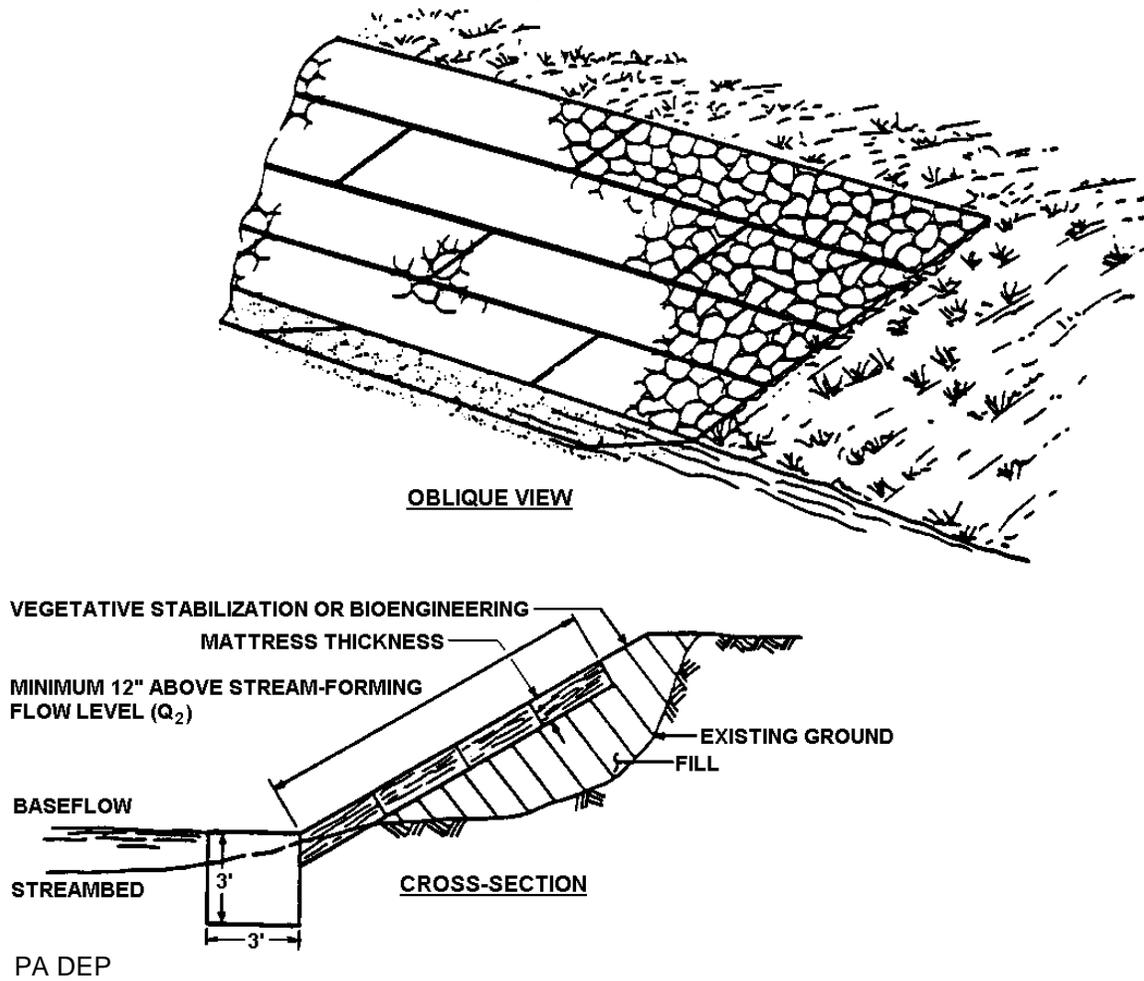
**FIGURE 15.3**  
**Gabion Streambank Protection**



Adapted from USDA, NRCS, *Engineering Field Handbook*, Chapter 16



**FIGURE 15.4  
Reno Mattress Streambank Protection**



Adapted from Portland, Oregon *Erosion Control Manual*

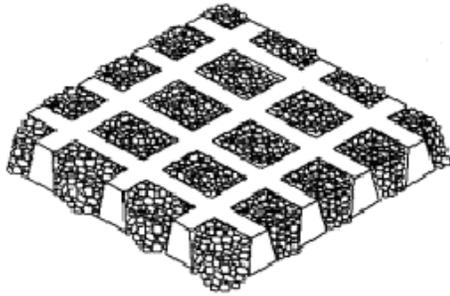
**NOTE: Gabion and Reno mattress streambank protection may not be grouted.**

GRID PAVERS may be used where anticipated velocities and shears are such that greater protection is needed than can be provided by other types of hard armor. Some types of grid pavers also offer the potential of establishing vegetation within the latticework, making the final product more aesthetically pleasing. Bank preparation and installation of the grid pavers should comply with the standards provided by the manufacturer. As with gabions and Reno mattress, care should be taken to adequately protect the upstream and downstream ends of the installation from scour. Figure 15.5 shows a typical installation. Construction details should conform to the manufacturer's specifications.

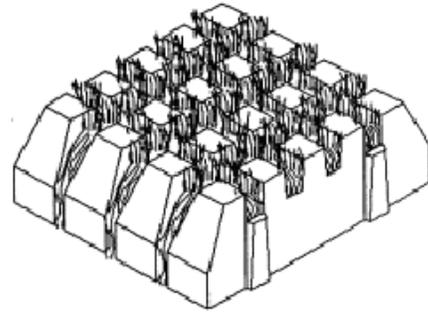


Source Unknown

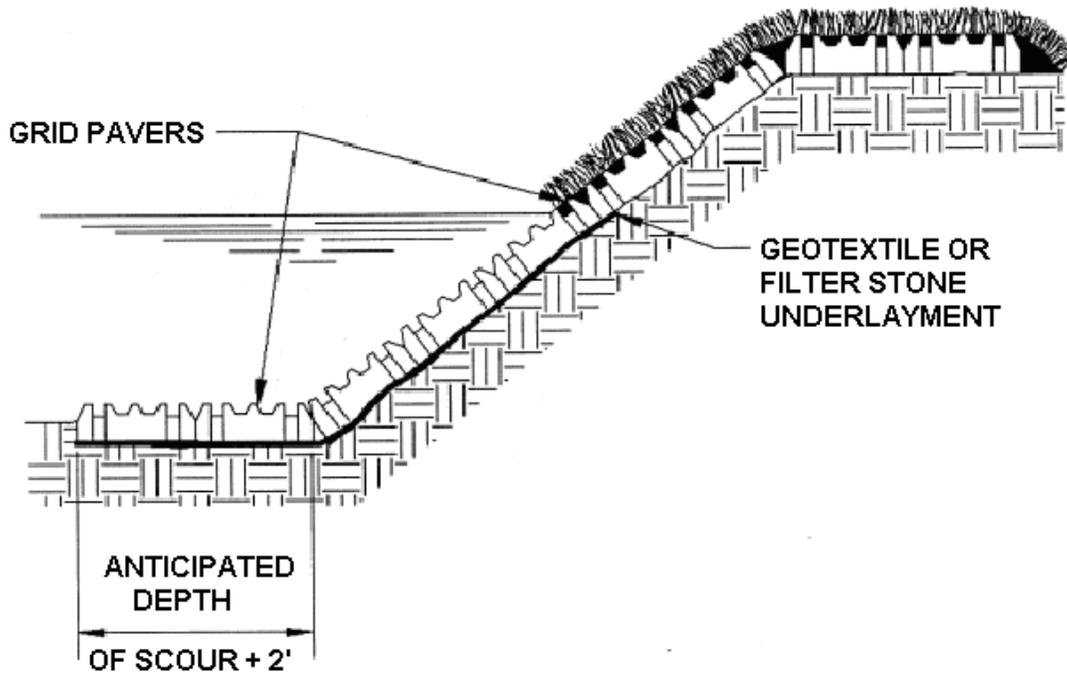
**FIGURE 15.5**  
**Grid Pavers**



**LATTICE UNIT**



**CASTELLATED  
UNIT**



Adapted from VA DSWC

## CELLULAR CONFINEMENT SYSTEMS

Cellular confinement systems may be used to stabilize streambanks when the manufacturer's recommendations are followed. The area of installation should be excavated as necessary so that the top of the panels is flush with, or slightly lower than, the adjacent terrain or final grade. The surface of the slope should be leveled, with stones and debris removed. Gullies should be filled and compacted. Unsuitable material should be replaced, the subgrade shaped and compacted, and an underlayment suitable for water bodies installed prior to stretching and anchoring the panel(s).



Bedford County Conservation District

## MISCELLANEOUS HARD ARMOR TECHNIQUES

Various other products exist on the market that may be suitable for streambank stabilization. These include but are not necessarily limited to: cable concrete, articulated concrete, and concrete jacks. Where such products are proposed, consideration should be given to specific site conditions such as access by construction equipment, anticipated flows, soil limitations, site dimensions, public use, and aesthetics, which might make some products less desirable than others. The manufacturer's recommendations, product limitations, cost, and project life are other factors that should be taken into account when choosing a suitable stabilization method.



Source Unknown

In each case, product specifications, installation details and sequencing, and maintenance standards should be included in the E&S Plan for each product proposed.

## FLUVIAL GEOMORPHOLOGY (FGM) TECHNIQUES



Stream channel stabilization using structures which mimic natural features (e.g. rock vanes, W rock weirs, J-hooks, etc.) have been shown to be quite effective when done correctly. They can also be very ineffective when the proper stream assessments, design, or construction practices have not been followed. The Department recognizes "Applied River Morphology" by Dave Rosgen and the NRCS website referenced at the beginning of this chapter for information regarding FGM techniques. The advantage for many of the methods described in these references is that flow is directed to the center of the channel, away from erodible banks.

## BIOENGINEERING

A number of bioengineering techniques have been developed in recent years that effectively stabilize streambanks while providing a more natural appearance than is afforded by hard armor. The following are a few examples:

**Live stakes** are woody vegetative cuttings, typically willow, dogwood or other species tolerant of occasional flooding, that are capable of rooting when inserted into the ground. When properly prepared, handled, and placed, the stakes will root, grow, and form a stabilizing root mat. This mat reinforces the soil by binding soil particles, extracting excess moisture, and providing a protective cover.



Source Unknown

Stakes should be freshly cut, healthy, straight, and at least 1 year old with side branches removed and bark intact. Cuttings should be ½” to 1 ½” diameter and 2 to 3 feet long. Bases should be cut cleanly at an angle to facilitate insertion into the soil. Tops should be square to aid in tamping.

### APPLICATIONS

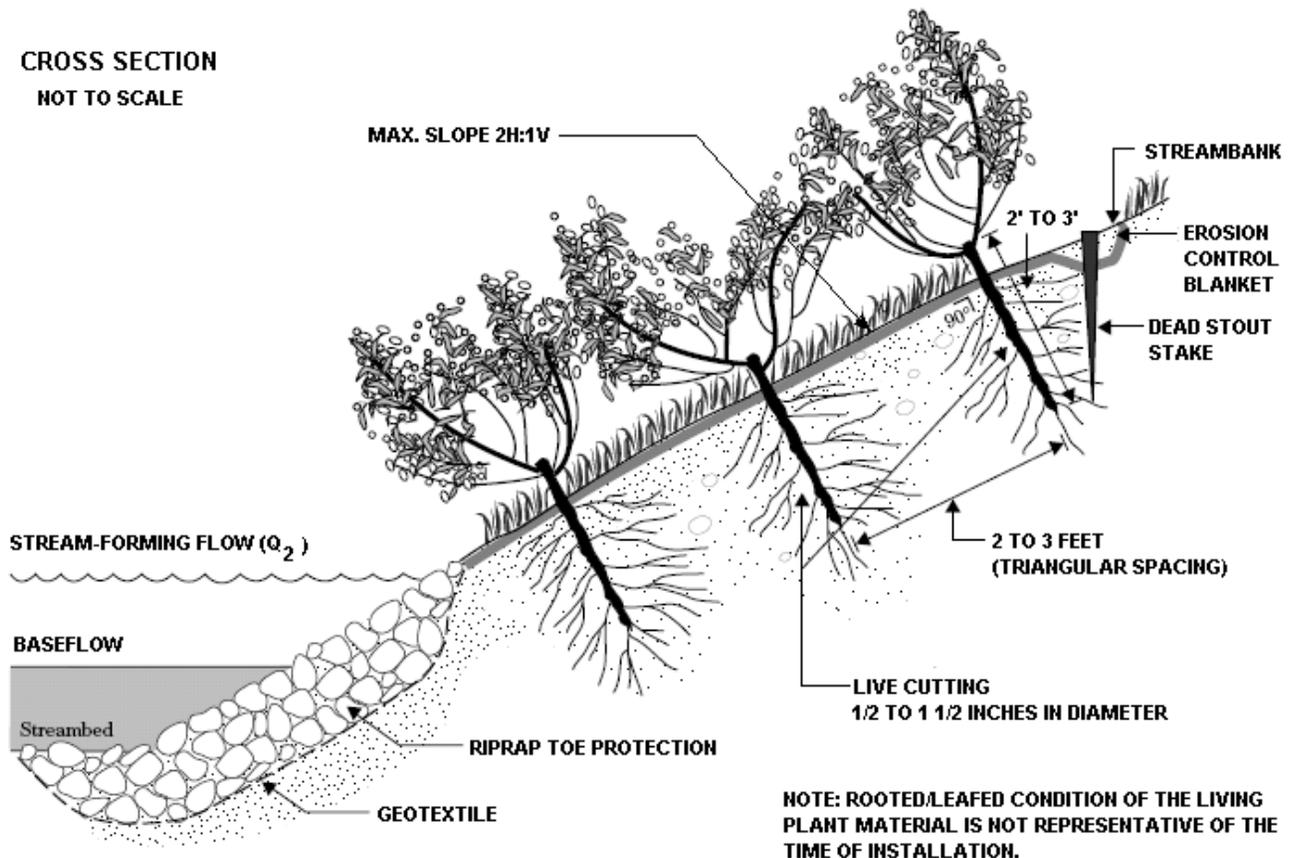
- Live Stakes should be installed during the dormant period.
- They are an effective streambank protection where site conditions are uncomplicated, construction time is limited, and an inexpensive method is desired.
- Live Stakes can be used to repair small earth slips and slumps in frequently wet areas.
- They can be used to peg down some erosion control blankets.

- Natural colonization by surrounding plant communities can be enhanced by the installation of live stakes.
- Intervening areas between other bioengineering techniques can be stabilized with live stakes.
- Live stakes enhance natural habitat.

#### INSTALLATION GUIDELINES

- Grade slopes to 2H:1V, or flatter for less cohesive soils or presence of sand lenses. Install suitable toe protection, such as properly sized riprap, below the stream-forming flow elevation (2-year storm =  $Q_2$ , often marked by a lack of vegetation).
- Erodible slopes should be blanketed prior to inserting cuttings.
- Keep cuttings fresh and moist after they have been cut into appropriate lengths. Cuttings should be installed the same day that they are prepared. If this is not possible, it is recommended that they be soaked 24 hours prior to installation.
- Tamp cuttings into the ground at 90 degrees to the slope and angled downstream. Approximately 4/5 of the cutting should be inserted into the ground. 2 to 5 bud scars should remain above ground. Buds should be oriented up, and soil should be firmly packed around the stake.
- Care should be taken to avoid splitting the stakes during installation. Split stakes should be replaced. If there is difficulty in tamping the stakes, an iron bar can be used to make a pilot hole.
- Stakes should be placed 2 to 3 feet apart using triangular spacing.

**FIGURE 15.6**  
**Live Stakes**



Adapted from USDA, NRCS, *Engineering Field Handbook*, Chapter 16

**Live fascines** are long bundles of branch cuttings bound together. They are typically placed in shallow trenches on slopes and streambanks to reduce erosion and shallow sliding.



Source Unknown

Cuttings should be ¼" to 1" in diameter cut from species that root easily and have long, straight branches, such as willow or dogwood. They should be tied together with untreated twine to form a live fascine ranging from 5 to 10 feet long depending upon site conditions and handling limitations. Diameters of the bundles should be 6 to 8 inches. All buds should be oriented in the same direction. Cuttings should be staggered so that tops are evenly distributed length wise along the bundle.

#### APPLICATIONS

- Live fascines are an effective streambank stabilization technique. When properly installed, there is a minimum of site disturbance.
- Live fascines can be used to protect slopes from shallow — 1 to 2 foot depth — slides.
- Typically, live fascines are placed above the bankfull elevation, although for small watersheds (< 2,000 acres) they may be placed below the bankfull elevation.
- Live fascines offer immediate protection from surface erosion.
- Conditions for native plant colonization are enhanced.



## INSTALLATION GUIDELINES

- Prepare the live fascine bundle and live stakes immediately prior to installation.
- Dig a 10" X 10" trench along contour at the base of the slope just above stream-forming flow, 2-year-24-hour peak flow elevation =  $Q_2$ . Note: A suitable toe protection such as, properly sized riprap, should be installed below the trench. See Figure 15.7.
- Additional trenches should be spaced on the slope at intervals shown in Table 15.1.
- Intervals between trenches should be seeded, mulched, and covered with a suitable erosion control blanket.
- Place live fascine into the trench as shown in Figure 15.7.
- Drive dead stakes directly through the live fascine until flush with the top of the bundle. Use extra stakes at bundle overlaps.
- Tamp in live stakes immediately downslope (adjacent to) the bundle leaving the top 3" of the live stake exposed.
- Place moist soil along the sides of the bundles leaving the top of the live fascine slightly exposed.

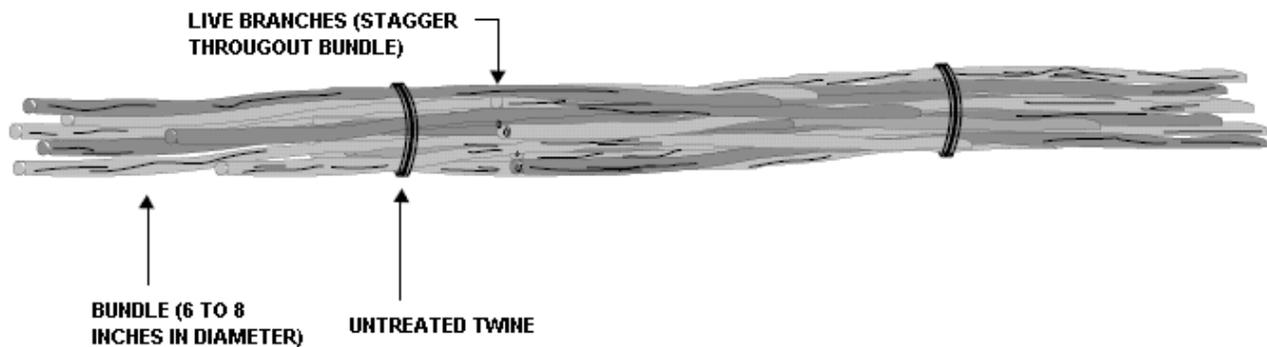
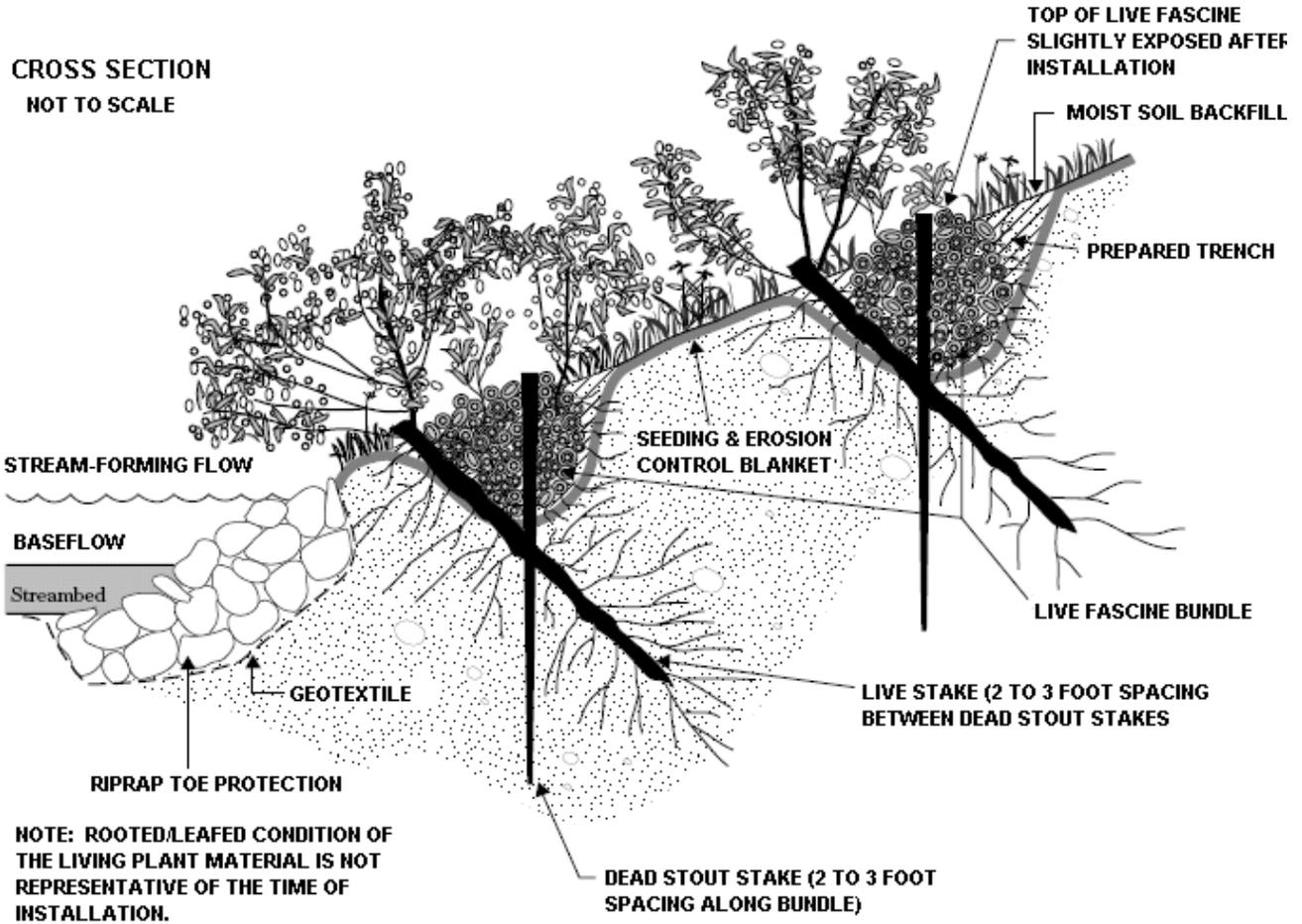
**TABLE 15.1**  
**Live Fascine Spacing (ft)**

Slope Steepness	Predominant Soils		
	Erosive	Non-erosive	Fill
3H:1V or flatter	3 to 5	5 to 7	3 to 5 *
Up to 1H:1V	3*	3 to 5	Not recommended

\* Not recommended alone

Adapted from USDA, NRCS, *Engineering Field Handbook*, Chapter 16

**FIGURE 15.7**  
**Live Fascines**



Adapted from USDA, NRCS, *Engineering Field Handbook*, Chapter 16

**Branchpacking** is the alternating of layers of live branches and compacted backfill to repair small scour holes and slips in streambanks. It provides a filter barrier that prevents erosion from bankfull and overbank flows. Branchpacking rapidly establishes a vegetated streambank and enhances colonization by native vegetation.



Source Unknown

Soil is immediately reinforced. The live branches serve as tensile reinforcement. Once the plant tops begin to grow, the branchpacking system becomes increasingly effective in retarding runoff and minimizing erosion. Sediment trapped by the vegetation refills the hole, while the roots spread throughout the surrounding soil to form a unified mass.

The live branches should range from ½” to 2” in diameter and be long enough to reach from the undisturbed soil at the back of the trench and extend slightly from the rebuilt streambank.

#### APPLICATIONS

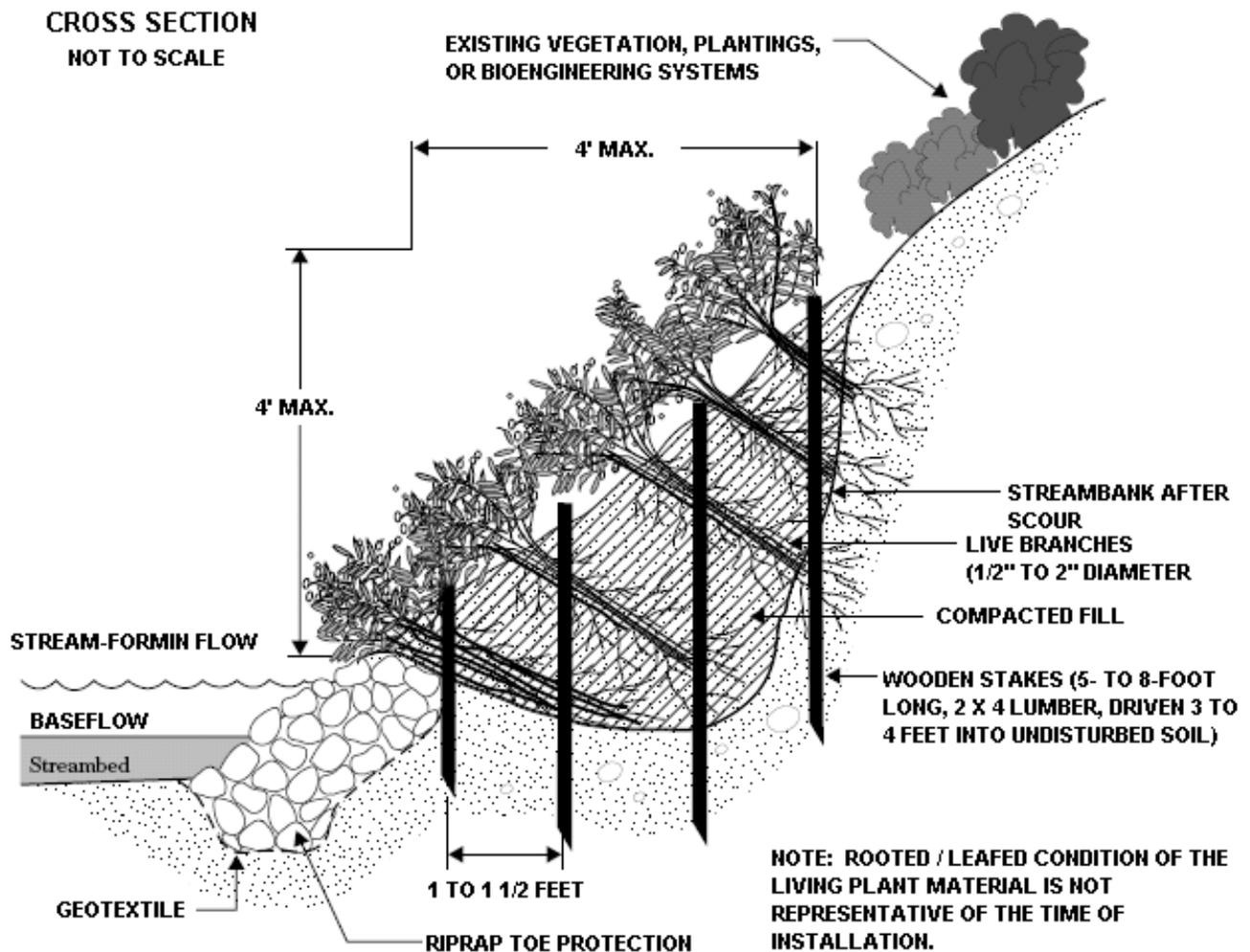
- Branchpacking is an effective means of repairing holes in streambanks ranging from 2 to 4 feet in height and depth.
- It is typically not effective in repairing slump areas greater than 4 feet high or 4 feet deep.

#### INSTALLATION GUIDELINES

- Divert any concentrated upslope runoff away from the repair area.
- Prepare the cuttings immediately prior to installation.
- Install suitable toe protection, such as properly sized riprap or fiber log, below the stream-forming flow elevation (2-year storm elevation =  $Q_2$ ).

- Beginning at the lowest point just above the  $Q_2$  elevation, drive wooden stakes vertically 3 to 4 feet into the ground. Stakes should be spaced 1 to 1 ½ feet apart as shown in Figure 15.8.
- Place initial layer of branches 4" to 6" thick in the bottom of the hole, between the vertical stakes and perpendicular to the slope face. Branches should be placed in a crisscross pattern with buds generally pointing toward the slope face. Basal ends of the branches should touch the undisturbed soil at the back of the hole.
- Cover each layer of branches with a layer of compacted soil to ensure soil contact with the branches.
- Subsequent layers of branches should be installed with the basal ends lower than the growing tips.
- The final layer should conform to the existing slope.

**FIGURE 15.8  
Branchpacking**



Adapted from USDA, NRCS, *Engineering Field Handbook*, Chapter 16

**Fabric encapsulated soil** is often used along with branchpacking to stabilize eroded streambanks. In this application, the soil layers between the branch layers are wrapped in a natural fabric like jute, which provides additional protection from erosion, especially when newly installed. Because of this, it can be placed on a 1H:1V slope.



Source Unknown

The system should be built during low flow conditions. It can be complex and relatively expensive, but it does produce a well-reinforced streambank. The system captures sediment, which rebuilds and further stabilizes the streambank. It produces rapid vegetative growth and enhances colonization by native vegetation.

The branches should be 4 to 6 feet long and cut from species that root easily.

#### APPLICATIONS

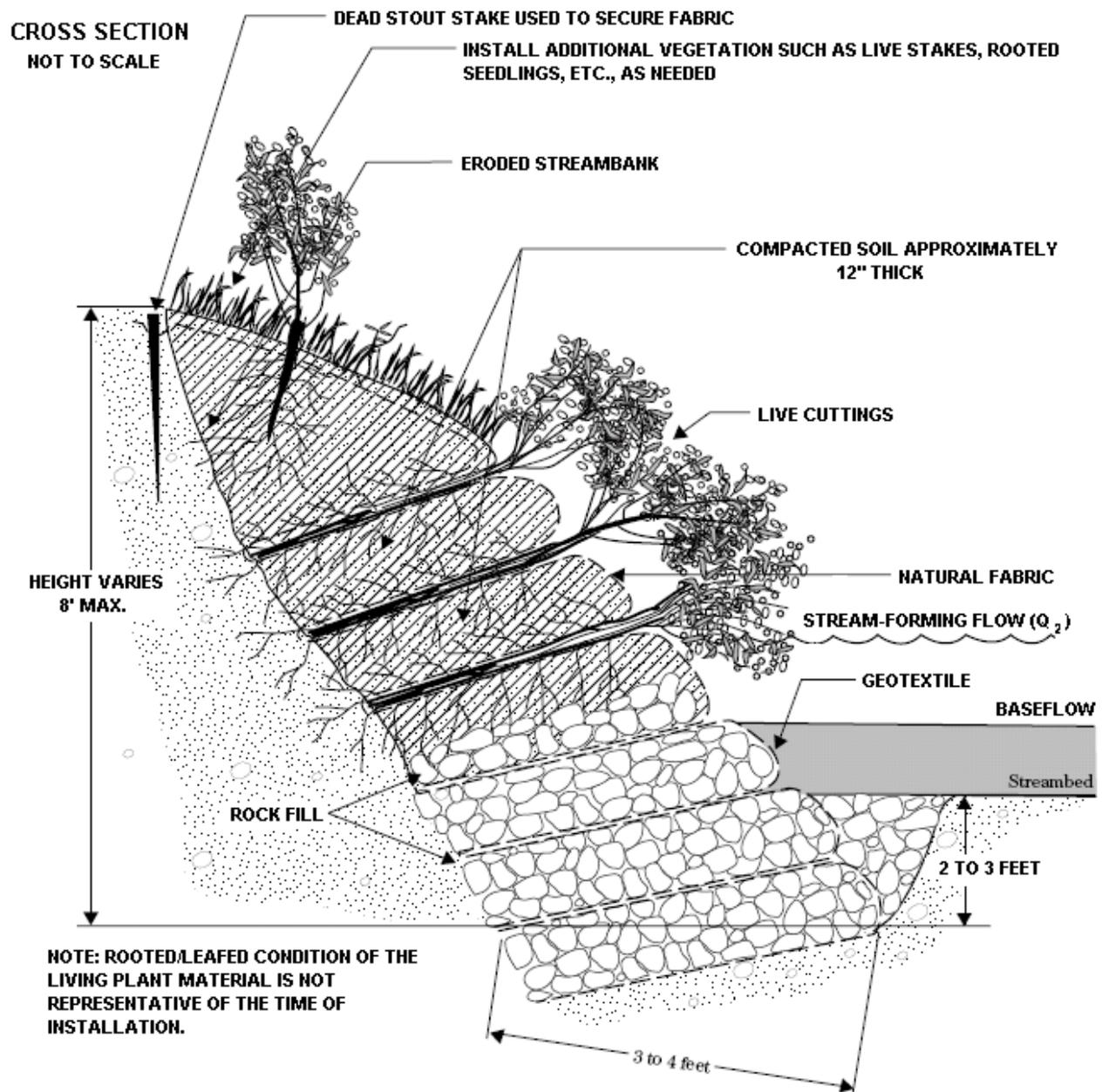
- Fabric encapsulated soil may be used above and below the stream-forming flow elevation (2-year storm elevation =  $Q_2$ ).
- Drainage areas should be less than 2,000 acres with stable streambeds.
- Useful in restoring eroded outside banks.
- Maximum bank height is 8 feet, including the 2 to 3 foot excavation below the streambed.
- Maximum length should not exceed 20 feet for any one unit.

#### INSTALLATION GUIDELINES

- Divert any concentrated upslope runoff away from the repair area.
- Excavate a trench 2 to 3 feet below the streambed elevation and 3 to 4 feet wide. Place geotextile in the trench, leaving a foot or two overhanging on the streamside face. Fill the trench with successive layers of rocks 2 to 3 inches in diameter encapsulated by the fabric. See Figure 15.9.

- Place a layer of soil on the top of the last layer of rock at the stream-forming flow elevation.
- At the stream-forming flow level, place a 6- to 8-inch layer of live branch cuttings on top of the last rock-filled capsule with the growing tips at right angles to the stream flow. The basal ends of the branches should touch the back of the excavated slope.
- Cover this layer of cuttings with the natural fabric, leaving an overhang. Place a 12-inch layer of soil suitable for plant growth on top of the fabric, and compact it to provide good contact with the underlying branches. Wrap the overhanging fabric over the soil to complete the capsule.
- Continue the process of alternating layers of cuttings and soil wrapped in fabric until the bank is restored to its original height.
- The final installation should match the existing bank slope. Branch cuttings should protrude only slightly from the fabric wraps.

**FIGURE 15.9**  
**Fabric Encapsulated Soil with Branchpacking**



Adapted from USDA, NRCS, *Engineering Field Handbook*, Chapter 16

**Fiber rolls**, or coir logs, are cylindrical structures composed of natural materials, such as coconut husk, bound together with twine. It is commonly manufactured in 12" and 18" diameters with lengths of 20 feet. Fiber rolls are often staked at the toe of slope (stream-forming elevation,  $Q_2$  level) below bioengineering systems (e.g. live stakes).



PA DEP

Fiber rolls encourage plant growth within the roll by trapping sediment.

Prefabricated rolls can be expensive. When wet, they can be rather heavy and cumbersome to handle.

Some manufacturers have estimated their effective life to be 6 to 10 years.

#### APPLICATIONS

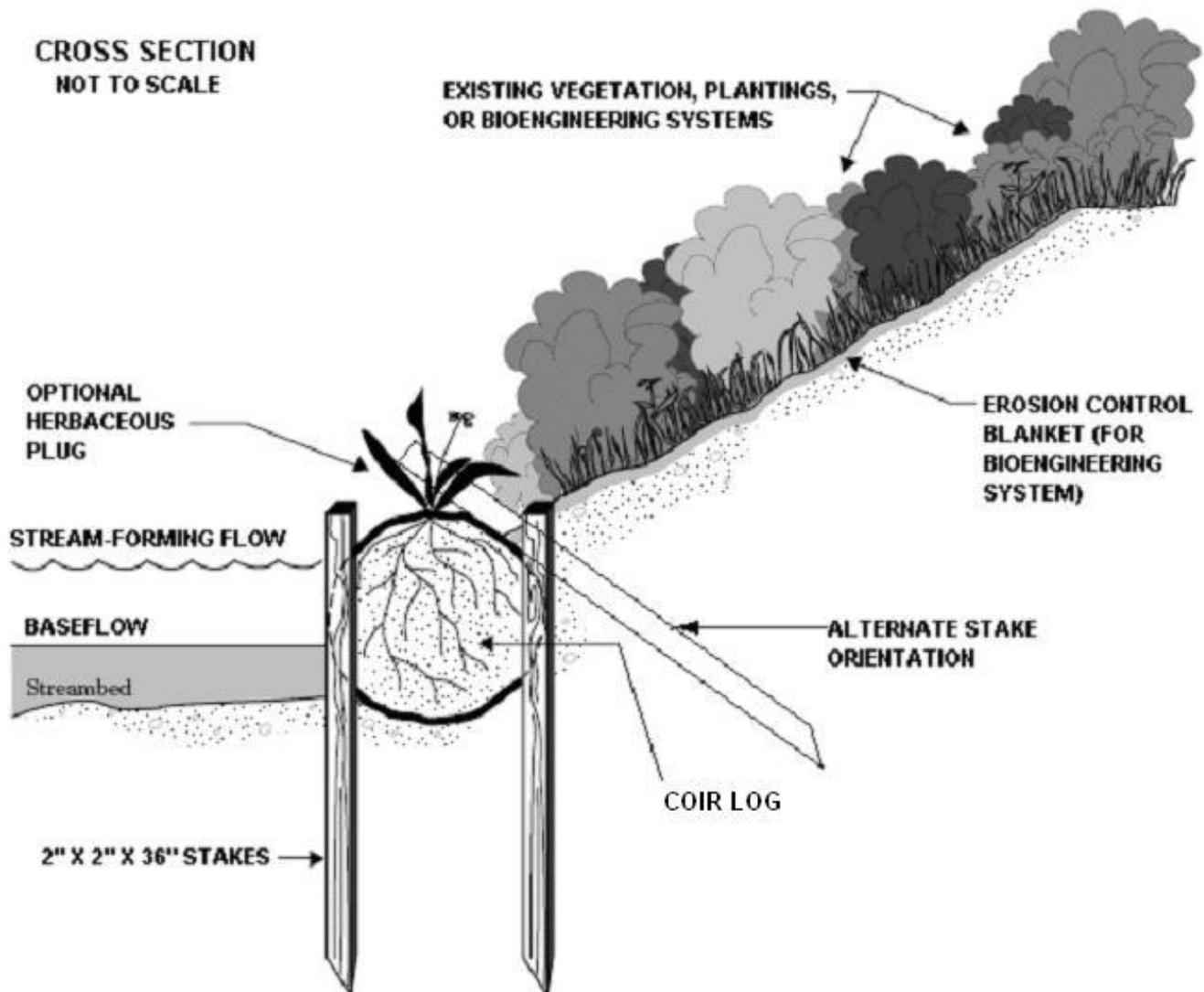
- Fiber rolls can be used to protect slopes from shallow slides or undermining.
- Because of their flexibility, they can be molded to the existing curvature of the streambank.

#### INSTALLATION GUIDELINES

- It is recommended that the fiber roll be saturated prior to installation to minimize floatation.
- Excavate a shallow trench at the toe of slope to a depth slightly below the channel grade.
- Place the fiber roll in the trench.
- Drive 2" X 2" X 36" stakes between the binding and the fiber, as shown in Figure 15.10. Stakes should be placed on 2 to 4 foot centers depending upon anticipated flow velocities. Tops of stakes should not extend above fiber roll. Where floatation is a possibility, the landward stakes may be driven perpendicular to the bank slope.

- In areas that experience ice or wave action, rolls may be secured with 16-gage wire tied around notched stakes.
- Backfill the soil behind the fiber roll.

**FIGURE 15.10**  
**Fiber Rolls**



Adapted from USDA, NRCS, *Engineering Field Handbook*, Chapter 16

For more information about these and other bioengineering techniques, Chapter 16 of the USDA, NRCS *Engineering Handbook* is recommended.



## CHAPTER 16 - GRADING STANDARDS



PA DEP

In order to ensure that these standards are incorporated into the earthmoving at a project site, the standard notes in Appendix C should be added to the plan drawings. Where these notes are already incorporated into bid packages, such as PennDOT projects, they need not be duplicated on the plan drawings. Items 11 and 13 should be incorporated into the overall plan design. Wherever low soil strength is indicated, Item 12 should be completed. The report should be included in the narrative unless the reviewing agency agrees that one copy may be provided separately.

Grading should comply with the following specifications for all sites:

1. Areas to be filled should be cleared, grubbed, and stripped of topsoil to remove trees, vegetation, roots and other objectionable material.
2. Areas which are to be topsoiled should be scarified to a depth of 3 to 5 inches, or 6 to 12 inches on compacted soils, prior to placement of topsoil. Areas to be vegetated should have a minimum 4 inches of topsoil in place prior to seeding and mulching. Fill outslopes should have a minimum of 2 inches of topsoil.
3. All earthen fills should be compacted as required to reduce erosion, slippage, settlement, subsidence or other related problems. Fill intended to support buildings, roadways, structures and conduits, etc. should be compacted in accordance with local requirements or codes.
4. All earthen fills should be placed in compacted layers not to exceed 9 inches in thickness.
5. Fill materials should be free of frozen particles, brush, roots, sod, or other foreign or objectionable materials that would interfere with or prevent construction of satisfactory fills.
6. Frozen materials or soft, mucky, or highly compressible materials should not be incorporated into fills.
7. Fill should not be placed on saturated or frozen surfaces.
8. Seeps or springs encountered during construction should be handled in accordance with standards and specifications for subsurface drains or other approved method.
9. All graded areas shall be permanently stabilized immediately upon reaching finished grade. Cut slopes in competent bedrock and rock fills need not be vegetated.
10. Stockpiles, borrow areas and spoil areas should be shown on the plan maps and should be subject to the provisions of these standards as well as those of the approved E&S plan. All appropriate permits/authorization should be obtained prior to earth disturbance activities within these areas

11. Wherever possible, fills should not be constructed from or built upon soils known to have low shear strength or that have been identified as “landslide prone” unless it can be shown that it can be done with an acceptable safety factor.
12. Wherever fills are to be constructed out of or onto soils identified as having low shear strength or are “landslide prone,” a report should be prepared by a professional geotechnical engineer or professional geologist which addresses the following:
  - a. The character of the bedrock and any adverse geologic condition in the area of the fills including previous slope failures.
  - b. A survey of all springs, seeps, and groundwater flow observed or anticipated during wet periods in the areas of the fills.
  - c. The maximum steepness of slope and height of fill to be constructed on the site.
  - d. A stability analysis including, but not limited to, strength parameters, pore pressures, and long-term seepage conditions. These data should be accompanied by a description of all engineering design assumptions and calculations as well as the alternatives considered in selecting the design specifications and testing methods.
  - e. The estimated factor of safety used to design the slopes. At a minimum, the long-term safety factor should be 1.5 for cuts or fills within 50 feet of public highways, railroads, surface waters, or where failure could endanger public safety. The safety factor should be a minimum of 1.25 for all other fills.
13. To avoid endangering regulated waters or public transportation facilities, a minimum setback should be maintained according to Table 16.1.

**TABLE 16.1**  
**Recommended Minimum Setbacks for Fill Placement in the Vicinity of Regulated Waters, Highways, Railroads, and Other Public Transportation Facilities\***

Height of Fill (ft)	Minimum Setback (ft)
< 10	10
10 - 25	25
25 - 50	50
> 50	1 ft of setback per ft of height

\* Greater setback distances might be needed if soil/bedrock, runoff, or groundwater conditions are such that a significant threat to public health and safety is posed or in special protection watersheds. Lesser setbacks may be considered by the Department in cases where special slope stability measures are undertaken or it can be shown that the desired long-term safety factor is provided.

## CHAPTER 17 - AREAS OF SPECIAL CONCERN

### SINKHOLE REPAIR



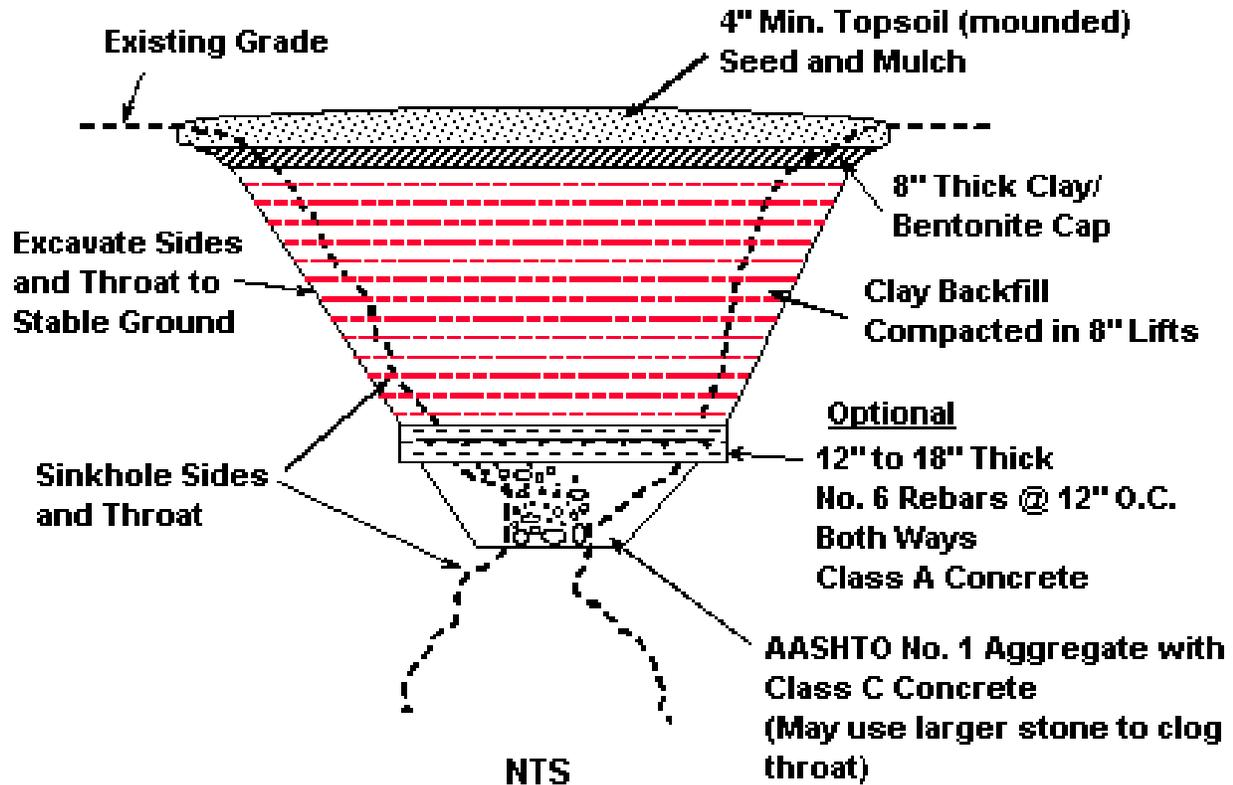
Source Unknown

Sinkholes vary greatly in size and nature. Therefore, specific methods of repairing sinkholes will depend on site conditions including but not necessarily limited to:

- Sinkhole diameter and depth
- Surface slope
- Presence or absence of surface runoff
- Soil type
- Connectivity to public or private water supplies
- Proximity of surface waters
- Ease of access by construction equipment
- Potential danger to the public or damage to structures

Due to the variable nature of sinkholes, they should be repaired under the direct observation and supervision of a professional geologist or licensed geotechnical engineer. Figures 17.1 through 17.4 are provided as general guidelines for the repair of sinkholes. They may be modified as necessary to accommodate specific site conditions. Site specific sinkhole repair plans will be reviewed on a case-by-case basis.

**FIGURE 17.1**  
Sinkhole Repair with a Bentonite Cap

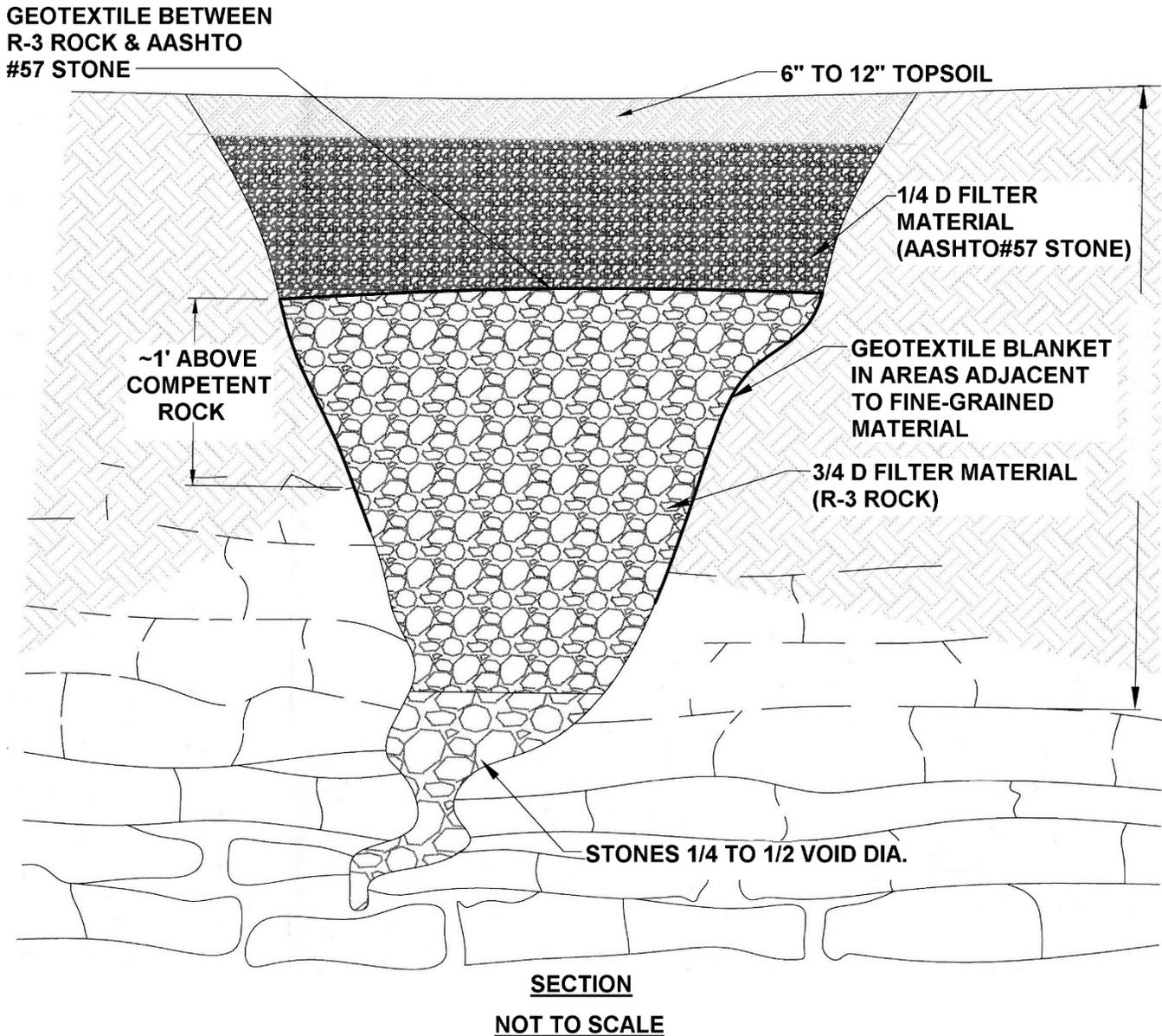


PA DEP

Loose material shall be excavated from the sinkhole and expose solution void(s) if possible. Enlarge sinkhole if necessary to allow for installation of filter materials. Occupational Safety and Health Administration (OSHA) regulations must be followed at all times during excavation.

Stones used for the "bridge" and filters shall have a moderately hard rock strength and be resistant to abrasion and degradation. Shale and similar soft and/or non-durable rock are not acceptable.

**FIGURE 17.2**  
**Sinkhole Repair with a Pervious Cover**

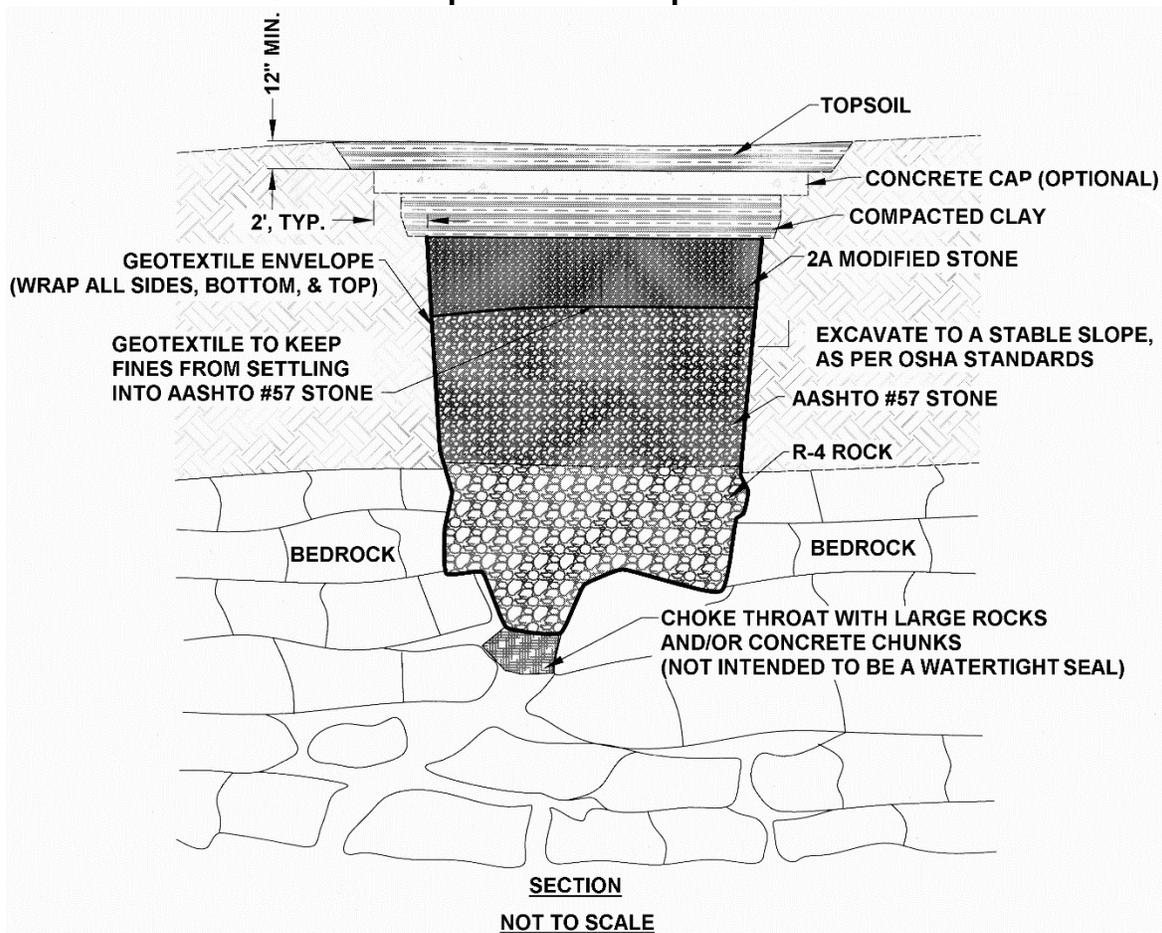


Adapted from USDA NRCS

Loose material shall be excavated from the sinkhole and expose solution void(s) if possible. Enlarge sinkhole if necessary to allow for installation of filter materials. OSHA regulations must be followed at all times during excavation.

Stones used for the "bridge" and filters shall have a moderately hard rock strength and be resistant to abrasion and degradation. Shale and similar soft and/or non-durable rock are not acceptable.

**FIGURE 17.3**  
**Sinkhole Repair with an Impervious Cover**



Adapted from USDA NRCS

**Loose material shall be excavated from the sinkhole and expose solution void(s) if possible. Enlarge sinkhole if necessary to allow for installation of filter materials. OSHA regulations must be followed at all times during excavation.**

**Geotextile shall be non-woven with a burst strength between 100 and 200 psi.**

**Select field stone(s) about 1.5 times larger than solution void(s) to form “bridge.” Place rock(s) so no large openings exist along the sides. Stones used for the “bridge” and filters shall have a moderately hard rock strength and be resistant to abrasion and degradation. Shale and similar soft and/or non-durable rock are not acceptable.**

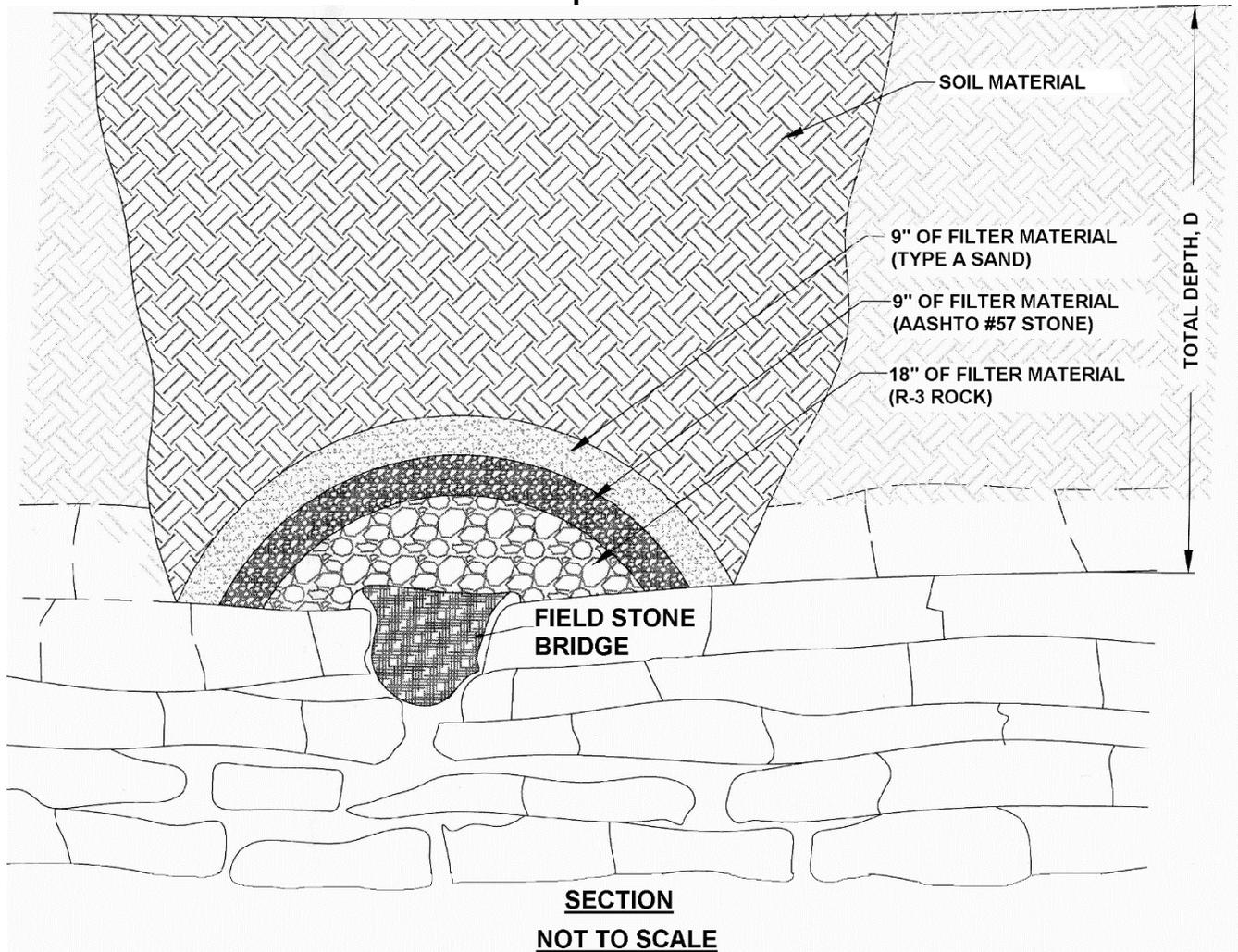
**Minimum thickness of R-4 rock is 18.” AASHTO #57 stone thickness shall be ¼ to ½ that of the R-4 rock. Minimum thickness of 2A modified crushed stone shall be 9”.** AASHTO #57 stone and 2A modified crushed stone shall be compacted after each placement.

**Compacted clay seal shall be a minimum of 12” thick. Clay shall be placed in 6” to 9” lifts and thoroughly compacted.**

**Concrete cap, which is optional, shall be a minimum of 8” thick. Use 4,000 psi concrete with 6” X 6” - 6 gauge welded wire fabric, or # 3 rebar on 18” O.C. both ways.**

**Topsoil shall be a minimum of 12” thick. Grade for positive drainage away from sinkhole area.**

**FIGURE 17.4**  
**Sinkhole Repair with Soil Cover**



Adapted from USDA NRCS

**Loose material shall be excavated from the sinkhole and expose solution void(s) if possible. Enlarge sinkhole if necessary to allow for installation of filter materials. OSHA regulations must be followed at all times during excavation.**

**Select field stone(s) about 1.5 times larger than solution void(s) to form “bridge.” Place rock(s) so no large openings exist along the sides. Stones used for the “bridge” and filters shall have a moderately hard rock strength and be resistant to abrasion and degradation. Shale and similar soft and/or non-durable rock are not acceptable.**

**Minimum thickness of R-3 rock is 18.” AASHTO #57 stone thickness shall be a minimum of 9” thick. Minimum thickness of type A sand shall be 9”. NOTE: A non-woven geotextile with a burst strength between 100 and 200 psi may be substituted for the AASHTO#57 stone and type A sand.**

**Soil shall be mineral soil with at least 12 % fines and overfilled by 5% to allow for settlement. Suitable soil from the excavation may be used. Any available topsoil shall be placed on top surface.**

## EROSION AND SEDIMENTATION CONTROL PRACTICES FOR CONTAMINATED SITES



Source Unknown

### **Background:**

A contaminated site is anywhere hazardous substances occur at a concentration sufficiently above background levels to cause an immediate or long-term hazard to human health or the environment. Experience has shown that sites previously used as industrial, agricultural or horticultural land are more likely than others to contain areas of contamination. Land can become contaminated when hazardous substances are leaked, spilled or disposed of. In some cases, the contamination was unintentional and occurred despite following recommended management practices. In the past, the use, handling and storage of hazardous chemicals were often of a lesser standard than is required today.

Contaminated sites are also commonly referred to as “Brownfield” sites. The EPA definition of a brownfield site is “*real property, the expansion, redevelopment, or reuse of which may be complicated by the presence or potential presence of a hazardous substance, pollutant, or contaminant*”. These sites can have a wide range of complexity, primarily dependent on previous, existing and proposed land use. For example, a contaminated site can range from a large former industrial site to the small former fuel station. It can also be a former orchard site. Further complications can arise when a contaminated site involves a proposed use with a higher risk of direct human contact, such as a residential development or a school site. This section of the manual is intended to cover and provide guidance on all these situations. It is recommended that the reader also cross reference Section 7.2 in the Pennsylvania Stormwater Best Management Practices Manual regarding stormwater best management practices for “Brownfields.” More specific guidance for remediation of contaminated sites can be found at [www.pacode.com/secure/data/025/chapter250/chap250toc.html](http://www.pacode.com/secure/data/025/chapter250/chap250toc.html) related to the Administration of the Land Recycling Program. Information can also be found online at [www.depweb.state.pa.us](http://www.depweb.state.pa.us) under keywords “Brownfield Redevelopment” and/or “Hazardous Site Cleanup Program.”

Pennsylvania encourages private cleanups of contaminated properties and the return of those sites to productive use. It has developed programs such as the *Act 2 - Land Recycling Program*, which was envisioned as an integral part of a sound land use policy that would help prevent the needless development of prime farmland, open space areas and natural areas; and the *Brownfield Action Team*, which expedites the remediation, reclamation, reuse and redevelopment of “brownfield” lands. It is important to point out that this section of the manual is applicable to all cleanup sites, not just those that



enter the Act 2 Program, which is a voluntary program. Contaminated sites may also go through federal or state-funded cleanups (e.g. CERCLA- a.k.a. Superfund; HSCA) or an independent private cleanup. More information is available at [www.epa.gov/superfund/](http://www.epa.gov/superfund/).

Most site cleanups result in some sort of land development. This normally occurs in two stages: (1) site remediation and (2) redevelopment. Planning, design and construction work associated with these two stages typically involve separate consultants, specialists and/or contractors. There are very few practitioners who perform both stages of work. This bifurcation of responsibility and know-how can potentially lead to miscommunication, mistakes and problems. It is critical for the landowner to ensure that both parties coordinate and are mutually agreeable to the proposed activities at the site.

### **Site Characterization, Risk Assessment and Remediation Plan:**

The risk associated with pollutants reaching surface waters is an inherent concern with contaminated sites. The Department's E&S program focuses on both direct pollution and potential pollution from erosion and sedimentation during earth disturbance activities. A higher risk of pollution exists on contaminated sites, since earth disturbance may uncover pollutants and/or create groundwater/surface water exposure pathways which were previously isolated or unavailable to human/ecological receptors. The potential for sediment mobility is typically addressed through the completion of a thorough site characterization and, when necessary, the formulation of a risk assessment and remediation plan.

The landowner is generally responsible and liable for cleaning up a contaminated site, even if contamination was caused by a previous owner. As part of the environmental due diligence process, a site characterization is required if there are indications that the soil contamination on-site poses a potential threat to water quality and/or human health. This characterization is conducted to determine the vertical and horizontal extent of contaminants in the soil and groundwater. This study is necessary before appropriate site remediation can be prescribed and should include an evaluation of groundwater contamination levels, soil contaminant levels, and the probability of the soil contaminants moving into the groundwater or surface waters. The type of development proposed for the site may also influence the degree of site characterization required. For instance, proposed residential developments may require more comprehensive characterization and remediation strategies than commercial or industrial development.

Where the site characterization or other soil testing confirms that the levels and extent of contaminants constitutes a potential threat to water quality and/or to human health, the applicant will be required to implement a remediation plan that is protective of public health and the environment. The remediation plan should be drafted as a "stand-alone" document. However, it should still be related and coordinated with the activities proposed in the E&S plan and PCSM plan. It should be noted that a "soil management plan" is considered a component of a remediation plan and should not be confused with an E&S Plan.

The combination of these reports and studies should, at a minimum, address the following criteria:

- (1) Procedures for managing soil, groundwater and other potentially-contaminated materials generated or exposed during construction, and for the reuse and/or off-site disposal of generated materials.
- (2) Procedures for addressing and resolving unanticipated environmental issues during construction.
- (3) A demonstration that the cleanup requirements and/or standards of the pertinent regulatory authority under Act 2 of 1995 and other state and federal laws governing contaminated sites have been satisfied.

How stormwater runoff is managed on contaminated sites, both during and after construction, depends largely on how the site is to be remediated and whether soil and/or groundwater contamination exists. It

is important to note that a site that has gone through a “clean-up” does not necessarily mean that contaminants no longer exist on the site.

Options for remediation may include, but are not limited to:

- **Excavation and hauling** of contaminated soil off-site and disposal at an approved hazardous waste facility.
- **Isolation of contaminants through appropriate capping and/or engineering controls.** Capping can include a soil in-situ cap or an impervious surface such as a pavement or building. Projects of this nature may involve onsite relocation of soil/materials from one area to another designated spot to facilitate traditional land development activities on the restored area. Caps are generally constructed of clean sediment, sand, or gravel, but can also include geotextiles, liners, or the addition of material, such as organic carbon, to attenuate the flux of contaminants into the overlying water. Thickness of the cap will typically depend on the exposure and risk determinations of the regulated substance, which would rely partly on the proposed use of the site. (i.e. residential vs. non-residential)
- **Vapor Barriers.** For occupied buildings, vapor intrusion may also become an issue, which is the movement of contaminant vapors, typically located in subsurface soil or ground water, into a building. Contaminant sources can be from man-made sources, such as chemical leaks or spills, or can be naturally occurring, such as radon gas. If vapor intrusion is an issue, then occupied buildings will require vapor barriers.  
*Link to Vapor Intrusion Policy - search for Document No. 253-0300-100 on DEP’s Electronic Library (eLibrary) at [www.eLibrary.dep.state.pa.us/dsweb/HomePage](http://www.eLibrary.dep.state.pa.us/dsweb/HomePage).*
- **Blending of soil.** This option is most commonly used for agricultural lands that were contaminated with pesticides or other chemicals. Blending of soil typically involves stripping the approximately 6 inches of topsoil, where many contaminants are often captured, and blending these stripped soils with the cleaner underlying soils to bring the site within an acceptable health standard or to achieve background standard.
- **Monitored Natural Attenuation** is a remedy that typically uses known, ongoing, naturally occurring processes to contain, destroy, or otherwise reduce the bioavailability or toxicity of contaminants in soil. Although burial by clean sediment is often the dominant process relied upon for natural recovery, multiple physical, biological, and chemical mechanisms frequently act together to reduce risk.
- **Pump and Treat.** This is for groundwater contamination requiring active treatment for areas of higher chemical concentration. This is most common for plumes of non-aqueous phase liquids (NAPL) or other chemical contaminants that can be separated from water, such as petroleum-based substances.

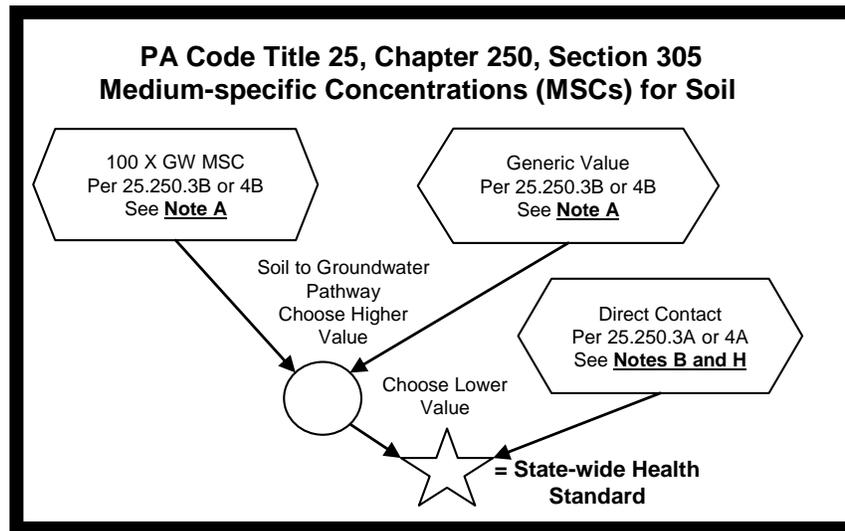
Steps in selecting a remediation strategy involve looking at each regulated substance and/ or release and should include:

- Determining if soil-to-groundwater pathways are exceeded;
- Determining if direct contact thresholds are exceeded, such as human exposure and inhalation/ingestion);
- Demonstration of attainment of the statewide residential or non-residential health standard, background standard, or site-specific standard. Where multiple releases occur on a property that produces distinctly separate zones of contamination, the characterization and subsequent attainment demonstrations apply individually to the separate zones, as per 25 Pa. Code § 250.702.

Flowchart A has been developed to aid in this often complex process, but the designer is advised to follow the guidelines within the regulations at 25 Pa. Code Chapter 250 related to the *Administration of the Land Recycling Program*. Further guidance can also be obtained by contacting your regional Environmental Cleanup Program or by visiting [www.depweb.state.pa.us](http://www.depweb.state.pa.us).







**NOTE A:** Refer to [www.pacode.com](http://www.pacode.com) Title 25, Chapter 250, Appendix A, Tables 3B and 4B, Columns: Used Aquifers, TDS≤2500, Residential (use residential for all sites because of possible groundwater lateral movement and leaching to adjacent residential properties), Compare measured concentration to higher value of [100 X GW MSC] and [Generic Value]

**NOTE B:** Refer to [www.pacode.com](http://www.pacode.com) Title 25, Chapter 250 Appendix A, Tables 3A and 4A, Columns: If proposed redevelopment is Non-Residential - Compare measured concentration to value under Non-residential Surface Soil 0-2 feet. If proposed redevelopment is Residential - Compare measured concentration to value under Residential 0-15 feet

**NOTE C:** If results from SPLP test indicate contaminant will not leach (or chemically bond with (groundwater) at in-situ temperature and pressure, contaminant is considered passing the SPLP test. Check with ECP if unsure of results.

**NOTE D:** Applicant needs to address proposed development activities in any non-tested areas of site (applicant may provide acceptable reason for not testing these other areas, but if still suspect suggest watertight joints for storm pipes or impervious liner for basins/swales)

**NOTE E:** Applicant needs to provide a note on the plan within the sequence of construction regarding: (1) contaminated soil shall be disposed of at either a) an approved disposal facility with an approved and current PADEP Soil Waste Management permit, or b) an approved landfill (typically disposal at a landfill does not require a Waste permit), and (2) "Waste materials, scrap or excess construction materials shall be collected, stored and disposed of in accordance with the Solid Waste Management Act (35 P. S. § § 6018.101—6018.1003), the Municipal Waste Planning, Recycling and Waste Reduction Act (53 P. S. § § 4000.101—4000.1904), The Clean Streams Law (35 P. S. § § 691.1—691.1001) and related rules and regulations. (Title 25, Chapter 105, Section 46a)

**NOTE F:** Known horizontal and vertical limits of regulated substance must be shown on all E&S plans.

**NOTE G:** Infiltration may be acceptable in original area of known regulated substance based on the remediation.

**NOTE H:** All OSHA general industry and construction standards (29 CFR 1910 and 1926) may apply to work at Brownfield sites, depending on the type of work performed and the hazards to which employees may be exposed. The NPDES permit for Construction Activities does not include requirements for direct contact, but rather covers the protection of Waters of the Commonwealth.

### **Common Contaminants of Concern:**

Two of the most common contaminants that are typically found in the soil of former industrial properties and may pose a risk for direct human contact are lead and arsenic. Some common site contaminants that readily volatilize and have indoor air health risks at low contaminant concentrations include trichloroethylene (TCE), tetrachloroethylene (PCE or PERC), and benzene. TCE has historically been utilized as a degreaser solvent, but is also found in spot removers, adhesives, and paint removers. PCE was also used as a degreaser and is the principal chemical used in most laundry dry-cleaning. Benzene is a component in gasoline, but is also used in the manufacture of some plastics, detergents, drugs, and pesticides. Other contaminants that are not as volatile, but still could be a concern at low indoor air concentrations include pesticides, polychlorinated biphenyls (PCBs), mercury, and selected semi-volatile organic compounds (SVOCs) found in diesel and fuel oil. Each of these contaminants and their medium-specific concentrations (MSCs) can be found in the regulations at 25 Pa. Code Chapter 250.

On some contaminated sites, it may be necessary to perform a leaching potential and/or fate and transport study to address concerns with the use of questionable material near an environmentally sensitive area or to determine the feasibility of a stormwater infiltration BMP. The Synthetic Precipitation Leaching Procedure (SPLP-EPA Method 1312 of SW-846) is acceptable to evaluate the potential for leaching metals into ground and surface waters. It provides a realistic assessment of metal mobility under actual field conditions, particularly during precipitation events — please refer to 25 Pa. Code §250.308(a). Contaminant concentrations in leachate should be compared to residential drinking water MSCs for user aquifers (TDS <2500) as referenced in Table 1 of Chapter 250 regulations.

### **E&S Best Management Practices (BMPs) for Contaminated Sites:**

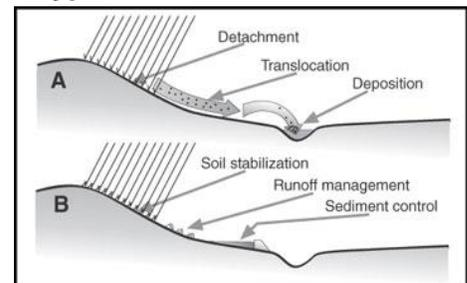
Some contaminants, such as heavy metals, are intimately associated with sediment and may be controlled by typical E&S BMPs. Some contaminants break down in the soil very slowly, while some do not break down at all, so they may be present on a site for a very long time. Some contaminants pass through the food chain and bioaccumulate in the tissues of fish, birds, livestock or humans. Therefore, knowledge of the characteristics of contaminants is very important when developing an E&S plan.

Contaminants that are water soluble and/or may be discharged in solution with water should utilize alternate methods. Additional BMPs may also be necessary when dealing with elevated levels of contaminants – even those that are non-water soluble. Generally speaking, erosion control is the preferred E&S BMP type since contaminated soils can be much more difficult to deal with after they have become disrupted and mobilized. Erosion control is achieved through avoidance, minimization and protection techniques (BMPs).

**Compost** is emerging as a very useful and effective material for various E&S uses - including contaminated sites.

- It can be spread as a mulch to provide temporary cover/stabilization,
- It can be fashioned into filter berms or stuffed into geotextile tubes/socks and used as a sediment barrier or other E&S BMP. These BMPs are handy on contaminated sites because they require little to no excavation to install.
- It removes solids, oil, grease, and heavy metals from stormwater runoff,
- It can cost-effectively remediate soils contaminated by hazardous waste.

### **Typical E&S Mechanisms:**



- It can capture and destroy industrial volatile organic chemicals (VOCs).
- It can provide a cost savings of up to 50 percent over conventional soil, water, and air pollution remediation technologies, where applicable.
- It can be used as a soil amendment to improve absorption and pollutant removal characteristics.

Additional information on compost can be found at: [www.epa.gov/compost](http://www.epa.gov/compost) and Chapter 11 of this manual

**Flocculants** have also gained popularity and can be useful on a contaminated site. They have been useful in settling out smaller silts and clays which are often very difficult to remove from sediment-laden water. The most common flocculant used is anionic polyacrylamide (PAMs), a manufactured and water soluble synthetic polymer available in dry powder form, liquid emulsion, and gelatinous blocks. It can be used either to prevent the detachment of soil particles during runoff events or to improve settling after erosion has taken place. For more information, see section on soil binders in Chapter 11 of this manual.

Though, E&S control has been around for quite some time, it is still an evolving industry. The recent attention to water quality and “green” development practices has also reinvigorated research and development into new and improved products for E&S including those made from recycled materials and those that can be reused. There have also been many products aimed specifically at capturing and treating polluted runoff. The reader is advised to check all their sources when preparing a plan to verify whether any new products or procedures have been developed that may be well-suited for their project.

### **Non-Structural Erosion Control Recommendations :**

1. **Minimize Disturbance:** Limit the extent and duration of earth disturbance activities.
  - *Spatially* -through phasing and/or using less intrusive earth disturbance techniques/equipment. This can also be accomplished by avoiding and minimizing the impact of ancillary areas that are not necessary for the project. Staking and protection fencing are effective tools for identifying these areas and are not to be disturbed by contractors/subcontractors.
  - *Temporally* - through seasonal/time restrictions and/or more careful attention to weather forecasting. Poor planning is often the cause of the most egregious sediment pollution events, despite the implementation of an adequate E&S plan.
2. **Construction Sequence** - Sequencing is an essential and effective method of dealing with issues commonly encountered on cleanup sites. For example, site remediation and redevelopment should never overlap within the same work area. Special monitoring may also be incorporated into a sequence, particularly when contamination is confined to a certain area. More information on sequencing can be found in Chapter 2 of this manual.
3. **Contingency Plan** - It is important to have a contingency plan and additional safety protocols in place in the event unexpected contamination is uncovered. The objective is to limit exposure and abate the problem as soon as possible. For non-contaminated sites this is done through a Pollution Prevention Contingency (PPC) Plan or Environmental Emergency Response Plan (EERP), which are normally generic in nature. Contaminated sites have an inherently higher risk of a release of pollutants. Therefore, the contingency plan should be more detailed and site-specific. **Dust Control and Suppression:** Appropriate practices and procedures are often necessary since earth disturbance activities can create significant sediment movement during dry and windy periods. Additional information on dust control can be found in Appendix H.

## **Structural (Stabilization) Erosion Control Recommendations:**

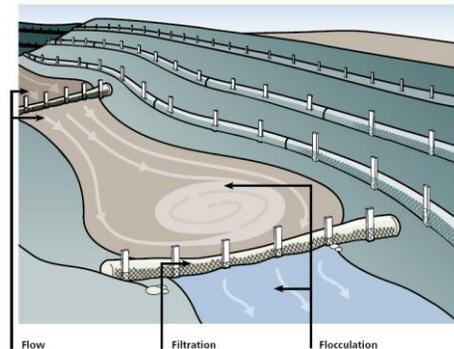
Immediate stabilization is essential on all sites involving earth disturbance and even more critical on contaminated sites. This can be achieved in several ways:

- Mats/blankets/linings/mulching - including compost. Temporary and/or permanent seeding/vegetation
- Isolation and shielding:
  - *Tarps* - particularly effective on small piles of contaminated soils which may need to sit for a period of time awaiting testing and handling operations. For example, remediation in the vicinity of an old underground storage tank.
  - *Temporary daily cover* - as used for landfills. This may be useful for larger stockpiles where tarps are not feasible.
  - *Impervious Cover* - though this could be an effective cap to isolate contaminants, it will have PCSM implications. Designer should be cautious and understand that additions to impervious cover and disturbed areas will lead to proportionally greater amounts of runoff volume that will need to be managed.

Though erosion controls are preferable, sedimentation controls are still an integral part of virtually every E&S plan. Sedimentation control is typically achieved through settling and filtration.

Besides the various conventional sedimentation BMPs found on construction sites, the following BMPs have been used successfully on contaminated sites:

- Compost filter berms
- Compost filter socks or weighted sediment filter tubes
- Flocculants
- Traps and basins with skimmer devices.
- Isolate, collect and dispose of hazardous materials/soil utilizing diversion berms, sumps, etc. This is more effective in small areas.





## NPDES Permits Involving Site Remediation and Redevelopment.



Source Unknown

In general, the risk of discharge will be directly related to the level of contamination at the site. General permits are ineligible for sites having the potential to discharge contaminants. In most cases, individual NPDES permits will be required to facilitate coordinated reviews with pertinent Department staff and to apply the additional level of review that may be necessary. Sites that have already been remediated to the Residential Statewide Health Standard for soils and groundwater are not considered to be contaminated and a general permit (PAG-02) can be authorized for earth disturbance activities on such sites.

Persons applying for an NPDES Permit for stormwater discharges associated with construction activities are required to employ environmental due diligence to determine if past and present land use may have resulted in the possibility of contamination on site. Examples of environmental due diligence, include but are not limited to:

- Determining previous uses of the land, or of any neighboring land.
- Determining if the site has the potential to be contaminated based on past activities.
- Checking with local government entities for any information that may be available about the area.
- Contacting agencies that may have dealings with contaminated sites and gathering any available information for the site in question.
- Performing a site inspection/investigation by an experienced practitioner since the level of risk can only be assessed on a site-by-site basis. Note, this may be the same as performing a site characterization.

If there is a possibility of soil and/or groundwater contamination, the applicant is required to have testing performed and to provide the sampling and test results in the appropriate section of the NPDES permit. The applicant should not refer to a lengthy site characterization/remediation plan that was submitted to a separate Department program, but rather submit a summary of all the pollutants of concern on a table and provide brief supporting documentation as necessary. In particular, information should be submitted regarding the potential of contaminant mobility due to proposed construction activities.

Based on the aforementioned, the following minimum information is required for projects involving potential pollutants on-site, including the Land Recycling Program under Act 2 of 1995, Superfund program or any other project involving site remediation and/or redevelopment.

### 1. Site Plan:

- a. The existing site plan should clearly show all areas that have been tested and which of those areas have been identified as “contaminated,” or are considered “hot spots.” For Act 2 sites, this would include all areas that do not meet the statewide residential health standard. More discussion on dealing with hot spot areas can be found in Appendix C of the Pennsylvania Stormwater Best Management Practices Manual.
- b. For those projects involving redevelopment, the proposed site plan and narrative should clearly show any remaining contaminated areas, including areas that were capped, that may be exposed as a result of the proposed work and explain how any conflicts have been resolved, including:
  - i. The placement of utilities, foundations or other subsurface systems that may compromise the clean-up remedy.

- ii. The siting and function of any proposed E&S BMP requiring an appreciable amount of excavation.
  - iii. The siting and function of any permanent stormwater BMP, particularly those proposing infiltration.
2. Narrative: To support the data tabulated in the NPDES application, the narrative will need to thoroughly address all the “potential pollutants”.
  - a. The applicant will need to explain how these pollutants are transported, either in-suspension as particulates, or in-solution as solutes, and whether traditional E&S and/or stormwater management BMPs, such as silt fence, inlet protection, etc. are capable or adequate to protect receiving waters. More discussion on physical forms of stormwater pollutants, including particulates and solutes, can be found in Chapter 2 of the Pennsylvania Stormwater Best Management Practices Manual.
  - b. The applicant may need to provide the results of a leachability test, such as a Synthetic Precipitate Leachate Procedure (SPLP), to address the migration potential of contaminants engrained in soils. This may be of particular interest in any areas proposed for infiltration for post construction stormwater management.
  - c. For those projects where traditional BMPs are found to be inadequate, additional BMPs addressing the contaminants of concern should be proposed. This should be addressed in the application narrative.
  - d. A summary of the site characterization/remediation plan and its ramifications on the E&S and PCSM plans.
3. A specific construction sequence accounting for the items listed above and earlier in this section is essential for any cleanup site.
4. As mentioned earlier in this section, it is imperative that all consultants and contractors are on the same page with respect to bridging the gap between site remediation and redevelopment. In some cases, it may be beneficial to have a joint meeting either prior to or during the permit review. However, it is the applicant’s responsibility — usually the landowner — to ensure that the project team is properly informed.

This above information should be supplied as part of the initial submission to the conservation district and/or Department. Addressing these concerns early in the permit process can significantly reduce delays.

The Department encourages pre-application meetings with both Waterways Engineering and Wetlands and/or Environmental Cleanup Program Staff for any contaminated site seeking additional guidance or to discuss any special precautions or needs.

**AUTHOR AND ACKNOWLEDGEMENTS:**

Domenic Rocco, P.E., CPESC, CPSWQ  
Chief, Stormwater Section  
PA Department of Environmental Protection  
Waterways Engineering and Wetlands Program

Special thanks to my Department colleagues, Christopher Smith and Darl Rosenquest, for their assistance in formulating this document.

## **BIBLIOGRAPHY AND REFERENCES**

PA DEP <http://www.depweb.state.pa.us>

Pennsylvania Stormwater Best Management Practices Manual (December 26, 2006)

PA Code, Title 25, Chapter 250 Regulations - Administration of the Land Recycling Program.  
<http://www.pacode.com>

U.S. Environmental Protection Agency:

<http://epa.gov/brownfields/>

<http://www.epa.gov/superfund/>

<http://nsdi.epa.gov/superfund/health/conmedia/sediment/pdfs/execsum.pdf>

<http://www.epa.gov/tio/tsp/download/chsoil.pdf>

<http://www.qedenv.com/files/Introduction%20to%20Pump%20&%20Treat%20Remediation.pdf>

<http://www.osha.gov/Publications/OSHA-brownfield-cleanup.pdf>

[www.brownfieldscenter.org](http://www.brownfieldscenter.org)

<http://www.ehso.com/contaminants.htm>

[http://www.mgkfbrownfields.com/brownfields\\_regulatory\\_programs2.html](http://www.mgkfbrownfields.com/brownfields_regulatory_programs2.html)

## SPECIAL PROTECTION WATERSHEDS



Source Unknown

### **Policy**

The Department is legally required to protect the existing uses of all surface waters, and the existing quality of HQ and EV Waters. Existing uses are water uses attained in the water body on or after November 28, 1975. Existing use protection includes protection of threatened and endangered species and their habitat in or on a surface water. For an earth disturbance activity that requires a permit under 25 Pa. Code Chapter 102, where a receiving surface water of this Commonwealth is classified as HQ or EV under 25 Pa. Code Chapter 93, the person proposing the earth disturbance activity is required to use a nondischarge alternative for both the E&S and PCSM BMPs that are cost-effective and environmentally sound when compared with the cost of the proposed discharge. If a nondischarge alternative is not cost-effective and environmentally sound, the person should use ABACT BMPs and assure that any discharge maintains and protects the existing quality of receiving surface waters and protects existing baseflow. In HQ waters only, DEP may allow a reduction in water quality if DEP finds, after satisfaction of intergovernmental coordination and public participation requirements, that allowing lower water quality is necessary to accommodate important economic or social development in the area in which the waters are located. In addition, DEP will assure that cost-effective and reasonable best management practices for nonpoint source control in HQ and EV waters are achieved.

### **Antidegradation**

Maintaining and protecting existing water quality for HQ waters, EV waters, and EV wetlands and protecting designated and existing uses for all surface waters is critical. The performance standards in 25 Pa. Code § 93.4c(a) and (b) (relating to implementation of antidegradation requirements), should be met by following the processes set forth in 25 Pa. Code §§ 102.4(b)(6) and 102.8(h). The Antidegradation Analysis outlines that process.

## **NONDISCHARGE ALTERNATIVES**

Earth disturbance activities within special protection watersheds are required to implement cost-effective and environmentally sound nondischarge alternatives unless nondischarge alternatives do not exist for the project. These alternatives shall be designed to:

- Minimize or eliminate accelerated erosion and sedimentation during the earth disturbance activity
- Achieve no net change from pre-development to post-development volume, rate and concentration of pollutants in stormwater runoff up to and including the 2-year/24-hour storm when compared to the stormwater rate, volume and quality prior to the earth disturbance activities
- Protect and maintain existing water quality of the receiving surface waters of this Commonwealth
- Preserve existing baseflow

Nondischarge alternatives for E&S Plans include, but are not necessarily limited to:

1. Alternative Siting
  - a. Alternative location of project - alternate location for the proposed project, including locating the project in other non-Special Protection watersheds.
  - b. Alternative configuration - designing the project, including the use of Low Impact Development (LID) and other measures in the layout of the project, to maximize the use of measures and techniques to protect and maintain existing quality of the receiving surface waters and preserve existing baseflow.
  - c. Alternative location of discharge - conveying any discharge from the project to another non-Special Protection watershed while assuring the maintenance and protection of the existing quality of receiving surface waters and the preservation of existing baseflow.
2. Limiting Disturbed Area - keeping all earth disturbance activities to the minimum required for safe and efficient completion of the project
3. Limiting Extent and Duration of the Disturbance
  - a. Staging the earth disturbance so that not all areas of a project site are disturbed at once
  - b. Keeping current with interim and final stabilization requirements, such as seeding and mulching, blanketing, or otherwise stabilizing sub-areas as they achieve final grade
4. A riparian forest buffer meeting the requirements of 25 Pa. Code §102.14, when included in the E&S Plan or PCSM Plan meeting the other requirements of Chapter 102, will satisfy 25 Pa. Code §§ 102.4(b)(6) and 102.8(h), unless data or information provided or available to the Department during the permit application or authorization review process shows that the proposed earth disturbance activity will degrade water quality.
5. Any combination of cost-effective and environmentally sound Best Management Practices in a "treatment train" that collectively eliminate the net change in stormwater volume, rate and quality for storm events up to and including the 2-year/24-hour storm when compared to the stormwater rate, volume and quality prior to the earth disturbance activities to maintain and protect the existing quality of the receiving surface waters of this Commonwealth.

## **ANTIDegradation BEST AVAILABLE COMBINATION OF TECHNOLOGIES (ABACT)**

In circumstances where a net change in stormwater runoff rate, volume or quality cannot be avoided an applicant should use environmentally sound and cost-effective ABACT BMPs in the E&S Plan and PCSM Plan to demonstrate that any change in stormwater runoff will maintain and protect the existing quality and water uses of receiving surface waters and preserve existing baseflow. Environmentally sound ABACT BMPs should take into consideration factors such as sensitivity of stream uses, including the timing of the discharge and the temperature of the discharge; transitory effects on aquatic organisms; the critical life stages of aquatic life; sensitivity of groundwater uses in the area; secondary

impacts, including suitability of geology or site conditions; management practice reliability; potential for spills and management practice failures; and operation and maintenance considerations.

A person proposing to conduct earth disturbance activities in a Special Protection Watershed must maintain and protect the existing quality of receiving surface waters and preserve existing baseflow. BMPs not listed below may be considered for use as ABACT, but it is the responsibility of the applicant to demonstrate that the proposed alternative BMPs will protect water quality and baseflow at least as well as those listed. In HQ waters only, a person may demonstrate justification that lowering the water quality in a receiving surface water is necessary to accommodate important economic or social development in the area in which the waters are located in accordance with the regulation at 25 Pa. Code § 93.4c(b)(1)(iii) and Chapter 10 of the Water Quality Antidegradation Implementation Guidance Manual (DEP Document ID No. 391-0300-002). This document may be accessed at <http://www.elibrary.dep.state.pa.us/dsweb/Get/Document-47704/391-0300-002.pdf>. **NOTE: Social and Economic Justification is not acceptable for projects located in EV watersheds including projects which discharge to EV wetlands.**

### **ABACT BMPs for E&S Plans**

The following BMPs may, on a case by case basis, be considered ABACT for E&S Plan purposes where individually or collectively they manage the difference in the net change in stormwater volume, rate, and quality for storm events up to and including the 2-year/24-hour storm when compared to the stormwater rate, volume and quality prior to the earth disturbance activities to maintain and protect the existing quality of the receiving surface waters of this Commonwealth:

#### Site Layout

1. Preserve Riparian buffers (min. 150 ft) wherever possible.
2. Preserve Vegetative Filter Strips wherever possible
3. Preserve Natural Watercourses wherever possible
4. Minimize cuts and fills

#### Site Access

1. Use Wash Racks on Rock Construction Entrances
2. Avoid Stream and Wetland Crossings wherever possible

#### Sediment Barriers

1. Minimize use of rock and filter fabric type BMPs and maximize use of compost BMPs
2. 6" Compost layer securely anchored on top of filter stone on Rock Filters and on Stone Inlet Protection

#### Channels

1. Temporary Channels designed to convey the peak discharge from a 5-yr/1-hr storm
2. Suitable protective lining provided for all channels
3. Minimize use of Riprap and Maximize use of Vegetative Linings

#### Sediment Basins

1. Principal Spillways
  - a. Designed to Skim water from the top 6 inches of the Dewatering Zone, or
  - b. Designed to provide Permanent Pools with 18" minimum depth
2. Minimum Flow Length to Width Ratio 4:1
3. Dewatering Zone dewateres in no less than 4 days and no more than 7 days when at full capacity

4. Sediment Forebay designed according to the standards described in Chapter 6 of DEP's Pennsylvania Stormwater Best Practices Manual
5. Silt Curtain installed between inflow(s) and principal spillway
6. Deepened Storage Zone
7. Compost layer around filter stone of dry basin riser and/or sediment storage dewatering facility
8. Use of impounded water for on-site dust control or irrigation
9. Flocculants

#### Sediment Traps

1. 4:1 Flow Length to Width Ratio
2. Minimum 6" Compost Layer securely anchored on top of filter stone of embankment spillways
3. Skimmer Dewatering
4. Silt Curtain installed between inflow(s) and principal spillway
5. Deepened Storage Zone
6. Compost layer around filter stone of dry basin riser and/or sediment storage dewatering facility
7. Use of impounded water for on-site dust control or irrigation
8. Flocculants

#### Stabilization

1. Immediately stabilize disturbed areas upon completion or temporary cessation of earth disturbance activity
2. Use of anionic PAM to stabilize exposed soils having high clay content
3. Blanket disturbed areas within 50 feet of a receiving surface water and on slopes 3H:1V or steeper.
4. Plant trees along proposed permanent channels

#### Flocculants

1. Where it can be shown that the use of flocculants can help to meet effluent standards, and that the use of such flocculants, consistent with the manufacturer's recommendations, does not in itself pose a threat to water quality, their use can be approved on a case-by-case basis.

## SLOPE FAILURES



PA DEP

### **The Problem**

In many locations throughout Pennsylvania slope failures have been a continuing problem affecting public as well as private construction projects, resulting in significant property damage and adversely affecting the safety and welfare of the citizens of Pennsylvania. The relation of slope failures to earthmoving projects has long been recognized. For example, Briggs et.al. made the following observation in Landsliding in Allegheny County, Pennsylvania (USGS Circular 728, 1975), "Most scientific and technical workers familiar with slope-stability problems in Allegheny County ...agree that man's modification of sensitive slopes causes more than 90 percent of the landsliding in the area." However, they go on to state that "If man causes landslides, he also can control or prevent them, actively by engineering or passively by judicious land use."

### **How to Address the Problem**

Many studies have been conducted and reports generated regarding the susceptibility of various locations within Pennsylvania to slope failures. It is not the intent of the Department to replicate that information in this manual. However, it is incumbent upon any prospective earthmover to employ due diligence in regard to the potential for slope failure resulting from the construction of a proposed project and take whatever steps are necessary to minimize or prevent slope failures, especially where this would endanger public safety or result in environmental or property damage.

For projects where significant potential for dangerous slope failures exists, appropriate steps should be taken to ascertain the probable nature of the failure, such as a geotechnical study, and all appropriate measures should be taken to alleviate the potential dangers. For lesser potential failures this may amount to following construction guidelines contained in a geotechnical report. For sites with greater



potential risk, the actual construction should be done under the supervision of an independent geotechnical engineer or geologist. While these measures can significantly increase initial costs for a project, they are small in comparison to remediation costs, not to mention collateral costs incurred by others who may be affected by large-scale slope failures. Sites with great potential for public risk or property damage should be avoided, if at all possible.

Table 17.1 is provided as an aid to identifying potential dangers and assessing the degree of risk involved. It should not be used by designers instead of any due diligence determination of specific site risks and remediation. It should become obvious that factors such as failure to properly handle surface and ground water; oversteepening of slopes by placing of fills and/or removing lateral support; failure to recognize geologic formations with low shear strengths; failure to recognize inherent weakness, such as linears, fractures, and joints, in otherwise competent bedrock; and improper blasting techniques can, and often do, lead to costly slope failures. These and other potential problems should be identified up front, during site design, to avoid huge remediation expenditures as well as environmental damage and threats to public safety.

**TABLE 17.1  
PROCESSES LEADING TO LANDSLIDES**

<b>CAUSE</b>	<b>TRIGGERING PROCESS OR EVENT</b>	<b>HOW THE FAILURE OCCURS</b>	<b>MOST SENSITIVE MATERIALS</b>	<b>PHYSICAL NATURE OF THE FAILURE</b>	<b>EFFECTS UPON SLOPE EQUILIBRIUM</b>
Slope Change	Construction or Erosion	1. Increase in height or steepness of slope	All materials	Changes state of stress in slope-forming materials	Increases shear stresses
			Stiff, fissured clay; shale	Changes state of stress and causes opening of joints	Increases shear stresses and initiates item # 8.
Tectonic Stresses	Tectonic Movements	2. Large-scale deformations in the earth's crust	All materials	Increases slope angle	Increases shear stresses
Tectonic Stresses or Explosives	Earthquakes or Blasting	3. High-frequency vibrations	All materials	Produces transitory change of stress	Increases shear stresses
			Loess, slightly cemented sand, and gravel	Damages intergranular bonds	Decreases cohesion and increases shear stresses
			Medium or fine loose sand in saturated state	Initiates rearrangement of grains	Spontaneous liquefaction
Weight of Slope-forming Material	Process which created the slope	4. Creep on slope	Stiff, fissured clay; shale; remnants of old slides	Opens up closed joints, produces new ones	Reduces cohesion, accelerates item # 8.
		5. Creep in weak stratum below foot of slope	Rigid materials resting on plastic ones		
Water	Rains or Melted Snow	6. Displacement of air in voids	Moist sand	Increases pore-water pressure	Decreases frictional resistance
		7. Displacement of air in open joints	Jointed rock, shale		
		8. Reduction of capillary pressure associated with swelling	Stiff, fissured clay and some shales	Causes swelling	Decrease of cohesion
		9. Chemical weathering	Rock of any kind	Weakens intergranular bonds	
	Frost	10. Expansion of water due to freezing	Jointed Rock	Widens existing joints, produces new ones	Decrease of frictional resistance
		11. Formation and subsequent melting of ice	Silt and Silty Sand	Increases water content of soil in frozen top layer	
	Dry spell	12. Shrinkage	Clay	Produces shrinkage cracks	Decrease of cohesion
	Rapid Drawdown	13. Produces seepage toward foot of slope	Fine sand, silt, previously drained	Produces excess pore-water pressure	Decrease of frictional resistance

CAUSE	TRIGGERING PROCESS OR EVENT	HOW THE FAILURE OCCURS	MOST SENSITIVE MATERIALS	PHYSICAL NATURE OF THE FAILURE	EFFECTS UPON SLOPE EQUILIBRIUM
Water	Rapid change of elevation of water table	14. Initiates rearrangement of grains	Medium or fine loose sand in saturated state	Spontaneous increase of pore-water pressure	Spontaneous liquefaction
	Rise of water table in distant aquifer	15. Causes a rise of piezometric surface in slope-forming material	Silt or sand layers between or below clay layers	Increases pore-water pressure	Decrease of frictional resistance
	Seepage from artificial source of water	16. Seepage toward slope	Saturated Silt		
		17. Displaces air in voids	Moist, fine Sand	Destroys intergranular bond	Decrease of cohesion
		18. Removes soluble binder	Loess	Undermines the slope	Increase of Shear Stress
		19. Subsurface Erosion	Find Sand or Silt		

Adapted from Terzaghi

The Department provides this table as a guide only. Factors not contained in this table may influence slope stability in certain localities. It is incumbent upon the designer to employ due diligence in identifying those factors for the project site.

## GEOTHERMAL WELL DRILLING



Drilling, testing, and development of high capacity geothermal wells can, if not properly managed, result in significant sediment pollution to receiving surface waters. This is especially true where well fields are installed, either during initial construction or as a retrofit to an existing site. Providing access to drill sites, as well as staging areas, should be addressed using the standards provided in Chapters 3 and 4.

The large volumes of water produced from each well can be quite turbid depending upon aquifer and surface conditions. Therefore care should be taken to protect surface waters during construction and development of geothermal wells.

A fact sheet describing typical erosion control BMPs during well drilling has been developed by the Department and is included in this manual as Appendix K. The standards set forth in that fact sheet should be incorporated into all water well drilling operations, including geothermal wells. Since the volumes of water produced by geothermal wells are typically much greater than for water supply wells, some additional precautions

Source Unknown

may be necessary depending upon discharge rates, sediment content, and site conditions.

On sites where a sediment basin or sediment trap is available to receive the discharges, these may be used as long as the water level within the basin or trap does not rise above the sediment clean-out elevation. Where sediment basins or traps are not available, control BMPs specific to the well drilling should be provided. Stormwater detention and/or retention ponds that are functioning as such may not be used as sediment removal BMPs for well drilling. Where flocculants are needed to meet effluent requirements, they may be approved on a case-by-case basis.

It is recommended that a test well be drilled with appropriate sediment removal BMPs in place in a proposed well field to determine the anticipated flow rate for each well in the well field. BMPs for the well field should then be designed to provide treatment for the total number of wells being drilled at any one time (i.e. test well flow rate X number of wells). It should be noted that flow rates will likely vary significantly from one well to the next. Therefore, the capacity of the BMPs provided should exceed the calculated required capacity by at least 1.5 times. Large well fields may require several test wells.

Designers should meet with conservation district staff prior to submitting applications that involve geothermal well testing and drilling in order to discuss site constraints and to develop an appropriate E&S plan. It is also recommended that well drilling contractors meet with conservation district prior to beginning drilling operations in order to discuss proper implementation of the E&S plan.

Special attention should be given to wells drilled in sensitive geologic formations, such as karst. Wells drilled in proximity to an active spring can, under some conditions like bedrock fracturing, cause a sediment discharge from the spring. Wherever such a discharge occurs, drilling operations should cease immediately and the regional office of the Department should be notified. Drilling operations should not resume until the Department is satisfied that the necessary precautions have been implemented to prevent future turbid discharges.

Likewise, should any test well or production well encounter a potentially toxic material like pyrite, the regional office of the Department should be contacted to determine what, if any, additional measures should be implemented. Depending upon the type of potential discharge, an individual NPDES permit may be required.

## **Design Considerations**

1. The site terrain, vegetative cover, soil types, geology, slopes, drainage areas, proximity to wetlands and waterways and other relevant site conditions should be investigated. This information should be provided on plan sheets submitted as part of the permit application.
2. Each well site area should be clearly shown on the plan maps as well as the limits of the well drilling area(s).
3. The sequencing of the drilling and installation of the wells will play a significant role in sizing the BMPs. The more wells that are drilled at one time, the larger the BMPs will need to be.
4. For large well fields, multiple test wells within the identified area should be drilled in order to get an overall average flow rate in gallons per minute (gpm) of water coming from the wells and to also know how deep the wells should be drilled. Appropriate temporary BMPs should be utilized as applicable while the test wells are being drilled. The number of test wells required will depend upon site conditions. Larger sites will need more test wells due to the potential for variations in groundwater flows. It is the designer's responsibility to make sure the BMPs are adequately sized to handle the flows coming from the wells. Too few test wells could result in underestimating the total flow and the BMPs being undersized. Retro-fitting the BMPs to compensate may be costly.
5. Once the following have been determined, the E&S BMPs should be designed accordingly: number and size of the geothermal wells, the number of wells being drilled at any one time, the maximum total rate of flow coming from the well field to each drainage area, and the stabilized method of conveyance.
6. A stabilized method of conveying treated water to a surface water should be provided. Appropriate precautions should be taken to prevent accelerated erosion in the receiving waterway or the approaches to it.

## **BMP Sizing**

### **Well (or Total Well Field) Flows Less Than 200 gpm**

A sump pit, as shown in Standard Construction Detail # 3-17, tank truck, or other approved method of pre-treatment as well as a pumped water filter bag, as shown in Standard Construction Detail # 3-16, should be provided for each well. Water from the well casing(s) should be directed through the sump pit, tank truck, or container prior to entering the pumped water filter bag so that well cuttings can be removed before entering the bag. The volume of the sump should be equal to the volume of water coming from each well in a 1 minute time period. All pump intakes should be floating and screened.

Pumping rates to any pumped water filter bag should not exceed  $\frac{1}{2}$  the maximum recommended by the manufacturer unless the bag is placed on a gravel bed.

## **Well (or Total Well Field) Flows Greater Than 200 gpm**

If the discharge volume can be controlled by the method described above for flows < 500 gpm, that method may be employed here as well. High volume flows which exceed that which can be controlled by pumped water filter bags should be directed to a higher volume BMP, such as a compost sock trap shown in Standard Construction Detail # 3-11, after well cuttings are removed. The trap should be designed to have a discharge rate through the socks of twice the combined pumping rates from all wells discharging to the trap. Storage volume for the trap should be at least 1.5 times that of the sump. If at any time, the water level in the trap rises to within 6 inches of the top of the trap, drilling should stop immediately. Discharges should then be directed to an alternate or replacement trap.

Wherever limited space or other constraints make it impossible to construct large BMPs to treat the well discharge, a manifold system using several smaller BMPs at once may be approved. A method of pretreatment as described above is required prior discharging to the selected BMPs. Then a number of E&S BMPs in parallel, such as pumped water filter bags, compost filter sock traps, sediment traps, etc., may be used. Prior approval by the conservation district or Department should be obtained before use.

In all cases sediment removal BMPs should be located between the well drilling activities and the receiving surface water(s). The flow path between the sediment removal BMP and the receiving surface water should be well-vegetated or otherwise stabilized (e.g. geotextile or gravel bed) extending from the BMP location to the receiving surface water. A vegetative filter strip may be considered a stabilized flow path.

Soil limitations, weather conditions, and unforeseen circumstances may necessitate additional measures be employed beyond the BMPs described above. One such measure is the use of soil binders. Erodible soils tend to have finer soil particles that may become locked in suspension. However, this consideration should be taken into account as early in the planning process as possible since these items are site specific. Refer to chapter 11 "Soil Binders" for additional information.

Where it has been shown that water contained in the sump pit, tank truck, or alternative storage container meets effluent standards for the receiving surface water without further filtration, it may be discharged directly to the receiving water so long as a stable method of discharge is provided and all Chapter 105 authorizations have been obtained.

If at any time the actual total flows exceed anticipated flows, the erosion and sediment control measures are found to be inadequately sized, or a sediment pollution event occurs, the drilling operation should shut down immediately and not resume until more appropriate E&S BMPs are provided. The conservation district or Department regional office should be contacted at this point. If it is determined that a reduced drilling program can be adequately treated by the existing BMPs, that may be authorized until a revised plan is approved.

## APPENDIX A. - CHECKLISTS

The Complete Plan Checklist is used during an administrative completeness review to determine if an E&S plan includes all required elements. This checklist is intended to serve as a tool to determine whether an E&S plan addresses all fifteen items required by 25 Pa. Code § 102.4(b)(5). For permitted sites, the checklist included in the application will serve this function, so no additional complete plan checklist is required.

The Standard E&S Plan Technical Review Checklist is used to determine the technical adequacy of an E&S plan. Information contained elsewhere in this manual provides additional guidance for preparing and reviewing the various BMPs used in a plan. This checklist is to be used by the reviewing agency to ensure the E&S plan meets the requirements of Chapter 102 and the standards of this manual. Although it should not be included as part of the plan submittal, the checklist can be used by plan designers to ensure that all the required elements have been submitted for review. The reviewing agency should keep a copy of the completed checklist in the project file.

The Expanded E&S Plan Technical Review Checklist is intended to provide more detailed guidance in the preparation and review of specific portions of the E&S Plan and/or proposed BMPs within the plan. New plan designers, as well as new plan review technicians, may find these checklists helpful in understanding what constitutes compliance in the various categories contained in the technical review checklist above. More experienced personnel may also find them helpful in working out difficult aspects of an E&S Plan.

## COMPLETE PLAN CHECKLIST

Project: \_\_\_\_\_

A. Written Narrative (Labeled "E&S" or "Erosion and Sediment Control Plan" and the final plan for construction). Written Narrative Includes the following:

1. 8.5" X 11" USGS map with outline of project area
2. Soils information (including hydric soils) types, depth, slope, and locations of soils
3. Physical characteristics and limitations of soils
4. Supporting calculations to show anticipated peak flows for the design storms
5. Analysis of the impact that runoff from the project site will have on existing downstream watercourses resistance to erosion.
6. Supporting calculations, standard worksheets, narrative description of the location(s) for all proposed E&S Control BMPs used before, during and after earth disturbance including but not limited to the following:
  - a. Channels
  - b. Sediment Basins
  - c. Sediment Traps
  - d. Filter Fabric Fencing
  - e. Outlet Protection
  - f. Other BMPs (Specify) \_\_\_\_\_
  - g. Other BMPs (Specify) \_\_\_\_\_
  - h. Other BMPs (Specify) \_\_\_\_\_
7. Analysis of geologic formation and soil conditions to cause pollution to surface waters where potential for such conditions is known to exist.

B. Plan drawings labeled "E&S" or "Erosion and Sediment Control Plan" and the final plan for construction. Drawings include the following:

1. Legend for any symbols that may be used on the drawing
2. Topographic features including existing contours, improvements, streams, wetlands, watercourses, etc. and sufficient surrounding area
3. Soil types and locations
4. Construction techniques or special considerations to address soil limitations
5. Limits of project area (NPDES boundary for permitted sites)
6. Limits of earth disturbance
7. Proposed alteration including proposed contours and proposed improvements
8. Maximum drainage areas to hydraulic BMPs during construction



9. Location of water which may receive runoff and receiving water classification pursuant to Chapter 93 and the "statewide existing use listing"
10. Standard Construction Details for all proposed E&S Control BMPs used before, during and after earth disturbance
11. Location of BMPs showing final contours
12. Complete and site specific sequence of BMP installation and removal including activities planned to limit exposed areas
13. Procedures or note requiring the proper recycling or disposal of waste materials associated with the project site
14. Maintenance Program including inspection schedule, sediment cleanout levels, repair parameters and time frames, and directions for sediment removal
15. Note explaining responsibilities for materials including definition of environmental due diligence and clean fill
16. If identified in item A.7 above, the locations of all bedrock or soil materials with potential to cause pollution to surface waters during earth moving operations (if such are identified in item A.7 above).
17. Evaluation of potential thermal impacts to surface waters from the earth disturbance activity and use of BMPs that avoid, minimize or mitigate potential pollution from thermal impacts
18. E&S Plan consistent with PCSM plan
19. Existing and proposed riparian forest buffers identified

## STANDARD E&S CONTROL PLAN TECHNICAL REVIEW CHECKLIST

Project: \_\_\_\_\_ NPDES/Project No. \_\_\_\_\_

Project Location: \_\_\_\_\_ Date: \_\_\_\_\_

Check-off: c = Complies, d = Deficient, na = Not applicable

Item Location: D = E&S Drawings, N = E&S Narrative, D&N = Drawings and Narrative

**“The E&S Plan shall be prepared by a person trained and experienced in E&S control methods and techniques applicable to the size and scope of the project being designed”**

Name \_\_\_\_\_ Address \_\_\_\_\_ Telephone No. \_\_\_\_\_ D&N

**“The existing topographic features of the project site and the immediate surrounding area”**

_____	Legible mapping	D
_____	Existing contours	D
_____	Type of cover	D
_____	Existing improvements, i.e. roads, buildings, utilities, etc.	D
_____	Sufficient surrounding area	D
_____	Complete mapping symbols legend and north arrow	D
_____	Location map, i.e. USGS	D or N

**“The types, depth, slope, locations and limitations of the soils”**

_____	Types, slopes, and locations of soil types	D
_____	Soil type use limitations and resolutions	N
_____	Hydric soils	N

**“The characteristics of the earth disturbance activity, including the past, present, and proposed land uses and the proposed alteration to the project site”**

_____	Proposed NPDES boundary and limits of construction	D
_____	Proposed contours/grades	D
_____	Proposed waterways and stormwater management facilities	D
_____	Proposed improvements, i.e., roads, buildings, utilities, etc.	D
_____	Past, present and proposed land uses	N

**“The volume and rate of runoff from the project area and its upstream watershed area”**

_____	Maximum during construction drainage areas	D
_____	Offsite drainage area(s) on USGS quadrangle map	N
_____	Discharge analysis provided for non-surface water discharges	N

**“The location of all surface waters of this Commonwealth that may receive runoff within or from the project site and their classification under Chapter 93”**

_____	Existing streams, wetlands, floodway, etc.	D
_____	Receiving watercourses	D
_____	Chapter 93 classification of streams or other waterbodies	N

**“A narrative description of the location and type of perimeter and onsite BMPs used before, during and after the earth disturbance activity”**

\_\_\_\_\_ Description provided in the narrative N

**“A sequence of BMP installation and removal in relation to the scheduling of earth disturbance activities, prior to, during and after earth disturbance activities that ensure the proper functioning of all BMPs”**

\_\_\_\_\_ Complete and site specific sequence of BMP installation D  
 \_\_\_\_\_ Activities planned to limit exposed areas D  
 \_\_\_\_\_ Removal of temporary BMPs D

**“Supporting calculations and measurements” and “Plan Drawings”**

Stabilized Construction Entrance

\_\_\_\_\_ Locations \_\_\_\_\_ Complete Details D

Silt Fencing

\_\_\_\_\_ Locations \_\_\_\_\_ Slope Length \_\_\_\_\_ Complete Details D

Channels

\_\_\_\_\_ Locations \_\_\_\_\_ Drainage Areas \_\_\_\_\_ D

\_\_\_\_\_ Contours and Grades \_\_\_\_\_ Complete details D

\_\_\_\_\_ Peak flow calculations \_\_\_\_\_ Capacity and freeboard calculations N

\_\_\_\_\_ Protective lining calculations N

Sediment Basins

\_\_\_\_\_ Locations \_\_\_\_\_ Contours \_\_\_\_\_ Drainage Areas D

\_\_\_\_\_ Complete berm & outlet details \_\_\_\_\_ Cleanout information D&N

\_\_\_\_\_ Discharge to surface waters or approved alternative D

\_\_\_\_\_ Structurally sound D&N

\_\_\_\_\_ Capacity calculations \_\_\_\_\_ Discharge calculations N

\_\_\_\_\_ Dewatering calculations N

Sediment Traps

\_\_\_\_\_ Locations \_\_\_\_\_ Contours \_\_\_\_\_ Drainage Areas D

\_\_\_\_\_ Complete berm & outlet details \_\_\_\_\_ Cleanout information D&N

\_\_\_\_\_ Discharge to surface waters or approved alternative D

\_\_\_\_\_ Capacity information \_\_\_\_\_ Discharge calculations N

Outlet Protection

\_\_\_\_\_ Locations \_\_\_\_\_ Complete Details D

\_\_\_\_\_ Design Calculations N

Inlet Protection

\_\_\_\_\_ Locations \_\_\_\_\_ Complete Details D

Other BMPs (specify) \_\_\_\_\_

\_\_\_\_\_ Locations \_\_\_\_\_ Complete Details D

\_\_\_\_\_ Design Calculations N

Temporary Stabilization

	Seed	Lime	Fertilizer	Mulch	Others	
Types	_____	_____	_____	_____	_____	D
Rates	_____	_____	_____	_____	_____	D

\_\_\_\_\_ D

Permanent Stabilization

\_\_\_\_\_ Topsoil replacement D

	Seed	Lime	Fertilizer	Mulch	Others	
Types	_____	_____	_____	_____	_____	D
Rates	_____	_____	_____	_____	_____	D

**“A maintenance program, which provides for the operation and maintenance of BMPs and the inspection of BMPs on a weekly basis and after each stormwater event, including the repair or replacement of BMPs to ensure effective and efficient operation. The program must provide for completion of a written report documenting each inspection and all BMP repair, or replacement and maintenance activities”**

_____	Inspection schedule	D
_____	Maximum sediment storage elevation/level in BMPs	D
_____	Time frames for completing specific maintenance and repairs for each type of BMP proposed.	D
_____	Site stabilization repair parameters and directions	D
_____	Disposal directions for sediment removed from BMPs	D
_____	Note provided requiring written documentation of inspection & repair/replacement of BMPs by contractor	D

**“Procedures which ensure that the proper measures for the recycling or disposal of materials associated with or from the project site will be undertaken in accordance with this title”**

_____	Project construction wastes are identified	N
_____	Directions for recycling/disposal of construction wastes	D
_____	Soil/rock disposal areas provided with BMPs	D

**“Identification of naturally occurring geologic formations or soil conditions that may have the potential to cause pollution during earth disturbance activities and include BMPs to avoid or minimize potential pollution and its impacts from the formations”**

_____	Potential for geologic or soil conditions to cause pollution during construction is addressed	N
_____	Instructions for proper handling and/or disposal of all materials that could cause pollution are provided	D
_____	Typical details are provided for proper handling and/or disposal of all such materials	D
_____	The locations of all such materials are clearly shown on the plan maps	D

**“Identification of the potential thermal impacts to surface waters of this Commonwealth from the earth disturbance activity including BMPs to avoid, minimize or mitigate potential pollution from thermal impacts”**

_____	Analysis of how thermal impacts associated with the project will be avoided is provided	N
_____	If impacts cannot be avoided, impacts are minimized and BMPs provided to mitigate impacts and protect and maintain surface water quality	D&N

**“The E&S Plan shall be planned, designed, and implemented to be consistent with the PCSM Plan under 25 Pa. Code § 102.8 (relating to PCSM requirements). Unless otherwise approved by the Department, the E&S Plan must be separate from the PCSM Plan and labeled “E&S” or “Erosion and Sediment Control Plan” and be the final plan for construction”**

_____	Overall plan supports the managing of stormwater for erosion and sediment control during earth disturbance activities	D&N
_____	BMPs are compatible with, and can be integrated into, structural and non-structural PCSM practices	D&N

**“Identification of existing and proposed riparian forest buffers”**

_____	Existing and/or proposed buffers are shown on the plan drawings.	D
-------	--	---

## EXPANDED E&S CONTROL PLAN TECHNICAL REVIEW CHECKLIST

This checklist is intended for instructional purposes only

(For use by new technicians or to illustrate check items in standard technical review checklist)

Project: \_\_\_\_\_ NPDES/Project No. \_\_\_\_\_

Project Location: \_\_\_\_\_ Date: \_\_\_\_\_

Check-off: c = Complies, d = Deficient, na = Not applicable

Item Location: D = E&S Drawings, N = E&S Narrative, D&N = Drawings and Narrative

**“The E&S Plan shall be prepared by a person trained and experienced in E&S control methods and techniques applicable to the size and scope of the project being designed”**

Name of Plan Designer Provided \_\_\_\_ Business Address \_\_\_\_ Telephone No. \_\_\_\_ Item Location  
D&N

**“The existing topographic features of the project site and the immediate surrounding area”**  
Complies Deficient N/A

<b>Legible mapping</b>			<b>D</b>
Printing and numbering can be easily read	<input type="checkbox"/>	<input type="checkbox"/>	
Scale is large enough to clearly depict the topography	<input type="checkbox"/>	<input type="checkbox"/>	
Clutter has been avoided	<input type="checkbox"/>	<input type="checkbox"/>	
Match Lines provided for adjacent sheets	<input type="checkbox"/>	<input type="checkbox"/>	
<b>Existing contours</b>			<b>D</b>
Dashed lines easily visible and labeled at 10' maximum intervals	<input type="checkbox"/>	<input type="checkbox"/>	
Maximum contour interval is 2 feet	<input type="checkbox"/>	<input type="checkbox"/>	
<b>Type of Cover</b>			<b>D</b>
Vegetative Cover shown on the plan map(s)	<input type="checkbox"/>	<input type="checkbox"/>	
<b>Existing improvements, i.e. roads, buildings, utilities, etc.</b>			<b>D</b>
All public and private roadways on or adjacent to the site/labeled	<input type="checkbox"/>	<input type="checkbox"/>	
All existing buildings, including those to be razed, on or adjacent	<input type="checkbox"/>	<input type="checkbox"/>	
All existing waterlines, sewer lines, power lines, gas lines, etc.	<input type="checkbox"/>	<input type="checkbox"/>	
<b>Sufficient surrounding area</b>			<b>D</b>
Drainage areas and receiving waters clearly shown	<input type="checkbox"/>	<input type="checkbox"/>	
<b>Complete mapping symbols legend and north arrow</b>			<b>D</b>
All symbols used on the maps are clearly identified	<input type="checkbox"/>	<input type="checkbox"/>	
North arrow provided on each map	<input type="checkbox"/>	<input type="checkbox"/>	
<b>Location map, i.e. USGS 7½ Min. Quad Map(s)</b>			<b>D or N</b>
Site Outline on Legible photo copy of appropriate Quad Map(s)	<input type="checkbox"/>	<input type="checkbox"/>	
Quad Name(s) provided	<input type="checkbox"/>	<input type="checkbox"/>	
Existing Vegetation	<input type="checkbox"/>	<input type="checkbox"/>	<b>D</b>

**“The types, depth, slope, locations and limitations of the soils”**

<b>Types, slopes, and locations of soil types</b>			<b>D or N</b>
Soil boundaries clearly shown on plan maps	<input type="checkbox"/>	<input type="checkbox"/>	
Legible photo copy of NRCS soil map with site outline provided	<input type="checkbox"/>	<input type="checkbox"/>	
Soil symbols identified	<input type="checkbox"/>	<input type="checkbox"/>	
<b>Soil type use limitations and resolutions</b>			<b>N</b>
Appropriate use limitations identified	<input type="checkbox"/>	<input type="checkbox"/>	
Resolutions to use limitations adequately described	<input type="checkbox"/>	<input type="checkbox"/>	
How resolutions are addressed in the E&S Plan described	<input type="checkbox"/>	<input type="checkbox"/>	

	Complies	Deficient	N/A	
<b>Hydric soils</b>			<input type="checkbox"/>	<b>N</b>
All Potentially hydric soils identified	<input type="checkbox"/>	<input type="checkbox"/>	<input type="checkbox"/>	
Wetland Determination provided	<input type="checkbox"/>	<input type="checkbox"/>	<input type="checkbox"/>	
Wetland Delineation provided	<input type="checkbox"/>	<input type="checkbox"/>	<input type="checkbox"/>	
<b>“The characteristics of the earth disturbance activity, including the past, present, and proposed land uses and the proposed alteration to the project site”</b>				
<b>Proposed NPDES boundary and limits of construction</b>			<input type="checkbox"/>	<b>D</b>
Permit boundary is clearly shown on all plan maps	<input type="checkbox"/>	<input type="checkbox"/>	<input type="checkbox"/>	
Limits of construction are clearly shown & within permit boundaries	<input type="checkbox"/>	<input type="checkbox"/>	<input type="checkbox"/>	
Phase boundaries are clearly shown	<input type="checkbox"/>	<input type="checkbox"/>	<input type="checkbox"/>	
<b>Proposed contours/grades</b>				<b>D</b>
All proposed grading is shown on Erosion Control Plan maps	<input type="checkbox"/>	<input type="checkbox"/>	<input type="checkbox"/>	
Proposed contours are solid lines, darker than existing contours	<input type="checkbox"/>	<input type="checkbox"/>	<input type="checkbox"/>	
Proposed contours tie into existing contours	<input type="checkbox"/>	<input type="checkbox"/>	<input type="checkbox"/>	
<b>Proposed waterways and stormwater management facilities</b>				<b>D</b>
All proposed channels, swales, and pipes clearly shown & labeled	<input type="checkbox"/>	<input type="checkbox"/>	<input type="checkbox"/>	
Transition points for all waterways clearly shown	<input type="checkbox"/>	<input type="checkbox"/>	<input type="checkbox"/>	
All PCSM BMP locations clearly shown	<input type="checkbox"/>	<input type="checkbox"/>	<input type="checkbox"/>	
All inlets identified/labeled	<input type="checkbox"/>	<input type="checkbox"/>	<input type="checkbox"/>	
All proposed outfalls clearly shown and labeled	<input type="checkbox"/>	<input type="checkbox"/>	<input type="checkbox"/>	
<b>Proposed improvements, i.e., roads, buildings, utilities, etc.</b>				<b>D</b>
All proposed roadways, including temporary access, clearly shown	<input type="checkbox"/>	<input type="checkbox"/>	<input type="checkbox"/>	
Proposed building footprints, if known, are clearly shown	<input type="checkbox"/>	<input type="checkbox"/>	<input type="checkbox"/>	
Lot boundaries and lot numbers are identified	<input type="checkbox"/>	<input type="checkbox"/>	<input type="checkbox"/>	
Proposed utility mainlines, including sanitary, clearly shown	<input type="checkbox"/>	<input type="checkbox"/>	<input type="checkbox"/>	
Station numbers provided	<input type="checkbox"/>	<input type="checkbox"/>	<input type="checkbox"/>	
Proposed stockpile locations shown	<input type="checkbox"/>	<input type="checkbox"/>	<input type="checkbox"/>	
Application has been made for required 105 permits	<input type="checkbox"/>	<input type="checkbox"/>	<input type="checkbox"/>	
<b>Past — at least 50 years, if known — present and proposed land uses</b>				<b>N</b>
Brownfields identified, including reclaimed brownfields, abandoned landfills, old farm dumps, spill locations, underground fuel storage tanks and contaminated soil	<input type="checkbox"/>	<input type="checkbox"/>	<input type="checkbox"/>	
Previously mined areas identified	<input type="checkbox"/>	<input type="checkbox"/>	<input type="checkbox"/>	
Previous fruit orchards identified	<input type="checkbox"/>	<input type="checkbox"/>	<input type="checkbox"/>	
Existing conditions adequately described	<input type="checkbox"/>	<input type="checkbox"/>	<input type="checkbox"/>	
Proposed land use adequately described	<input type="checkbox"/>	<input type="checkbox"/>	<input type="checkbox"/>	
<b>“The volume and rate of runoff from the project area and its upstream watershed area”</b>				
<b>Maximum drainage areas during construction</b>				<b>D or N</b>
Drainage areas for all proposed basins, traps and channels shown correctly on plan maps	<input type="checkbox"/>	<input type="checkbox"/>	<input type="checkbox"/>	
Photo copy of work map showing drainage areas provided	<input type="checkbox"/>	<input type="checkbox"/>	<input type="checkbox"/>	
Drainage areas used are maximums during construction	<input type="checkbox"/>	<input type="checkbox"/>	<input type="checkbox"/>	
<b>Offsite drainage area(s) on USGS quadrangle map</b>				<b>N</b>
Drainage areas too large for the plan maps are shown on the Location map or other photo copy of USGS Quad map	<input type="checkbox"/>	<input type="checkbox"/>	<input type="checkbox"/>	
Discharge analysis provided (non-surface water discharges)	<input type="checkbox"/>	<input type="checkbox"/>	<input type="checkbox"/>	<b>N</b>
Flowage easements addressed	<input type="checkbox"/>	<input type="checkbox"/>	<input type="checkbox"/>	

**“The location of all surface waters of this Commonwealth which may receive runoff within or from the project site and their classification under Chapter 93”**

	Complies	Deficient	N/A	
<b>Existing streams, wetlands, floodway, etc.</b>			<input type="checkbox"/>	<b>D</b>
All existing stream channels — defined bed and bank — within or adjacent to the site are shown on the plan map(s) & labeled	<input type="checkbox"/>	<input type="checkbox"/>	<input type="checkbox"/>	
All existing wetlands and springs are shown on the plan map(s)	<input type="checkbox"/>	<input type="checkbox"/>	<input type="checkbox"/>	
Wetlands shown are consistent with delineation report	<input type="checkbox"/>	<input type="checkbox"/>	<input type="checkbox"/>	
For streams with FEMA study, 100-year floodways are shown	<input type="checkbox"/>	<input type="checkbox"/>	<input type="checkbox"/>	
<b>Receiving watercourses</b>				<b>D</b>
All receiving storm sewer systems are clearly shown and labeled	<input type="checkbox"/>	<input type="checkbox"/>	<input type="checkbox"/>	
Receiving waters beyond plan map coverage shown on USGS map	<input type="checkbox"/>	<input type="checkbox"/>	<input type="checkbox"/>	
Downstream analysis provided for proposed discharges where needed	<input type="checkbox"/>	<input type="checkbox"/>	<input type="checkbox"/>	<b>N</b>
<b>Chapter 93 classification of streams or other water bodies</b>				<b>N</b>
All special protection waters are clearly identified	<input type="checkbox"/>	<input type="checkbox"/>	<input type="checkbox"/>	
All existing uses are clearly identified	<input type="checkbox"/>	<input type="checkbox"/>	<input type="checkbox"/>	

**“A narrative description of the location and type of perimeter and onsite BMPs used before, during and after the earth disturbance activity”**

\_\_\_\_\_ Description provided in the narrative **N**

**“A sequence of BMP installation and removal in relation to the scheduling of earth disturbance activities, prior to, during and after earth disturbance activities that ensure the proper functioning of all BMPs”**

<b>Complete and site specific sequence of BMP installation</b>				<b>D</b>
Access to site and perimeter BMPs is adequately addressed	<input type="checkbox"/>	<input type="checkbox"/>	<input type="checkbox"/>	
Suitable BMPs are in place for clearing and grubbing and demolition operations	<input type="checkbox"/>	<input type="checkbox"/>	<input type="checkbox"/>	
Sequence addresses installation of all proposed E&S BMPs	<input type="checkbox"/>	<input type="checkbox"/>	<input type="checkbox"/>	
Proper handling of base flow during work within stream channels	<input type="checkbox"/>	<input type="checkbox"/>	<input type="checkbox"/>	
Runoff from access roads and utility lines properly addressed	<input type="checkbox"/>	<input type="checkbox"/>	<input type="checkbox"/>	
BMPs outletting to proposed structures are adequately addressed	<input type="checkbox"/>	<input type="checkbox"/>	<input type="checkbox"/>	
Suitable BMPs are in place for all stages of construction	<input type="checkbox"/>	<input type="checkbox"/>	<input type="checkbox"/>	
Suitable BMPs are in place for PCSM BMP installation	<input type="checkbox"/>	<input type="checkbox"/>	<input type="checkbox"/>	
Appropriate instructions provided to avoid compaction of infiltration areas	<input type="checkbox"/>	<input type="checkbox"/>	<input type="checkbox"/>	
Information is detailed and site specific	<input type="checkbox"/>	<input type="checkbox"/>	<input type="checkbox"/>	
No maintenance items	<input type="checkbox"/>	<input type="checkbox"/>	<input type="checkbox"/>	
<b>Activities planned to limit exposed areas</b>				<b>D</b>
Special value areas are kept outside the limits of construction	<input type="checkbox"/>	<input type="checkbox"/>	<input type="checkbox"/>	
Initial clearing is limited to areas of perimeter BMPs	<input type="checkbox"/>	<input type="checkbox"/>	<input type="checkbox"/>	
Sequence addresses field-marking the limits of disturbance	<input type="checkbox"/>	<input type="checkbox"/>	<input type="checkbox"/>	
Cuts and fills are stabilized in regular vertical increments	<input type="checkbox"/>	<input type="checkbox"/>	<input type="checkbox"/>	
Limits are placed on utility trenching	<input type="checkbox"/>	<input type="checkbox"/>	<input type="checkbox"/>	
Disturbed subareas are stabilized upon reaching final grade	<input type="checkbox"/>	<input type="checkbox"/>	<input type="checkbox"/>	
Blanketing is specified for disturbances in critical areas	<input type="checkbox"/>	<input type="checkbox"/>	<input type="checkbox"/>	
Immediate stabilization provided in special protection watersheds	<input type="checkbox"/>	<input type="checkbox"/>	<input type="checkbox"/>	

	Complies	Deficient	N/A	
<b>Removal of temporary BMPs</b>				<b>D</b>
Instructions provided for topsoil replacement, addition of soil amendments, seeding and mulching	<input type="checkbox"/>	<input type="checkbox"/>	<input type="checkbox"/>	
Conditions of stabilization are adequately defined	<input type="checkbox"/>	<input type="checkbox"/>	<input type="checkbox"/>	
Specific instructions given for removal/conversion of basins & traps	<input type="checkbox"/>	<input type="checkbox"/>	<input type="checkbox"/>	
Removal of all temporary BMPs is addressed	<input type="checkbox"/>	<input type="checkbox"/>	<input type="checkbox"/>	
Instructions provided for proper installation of PCSM BMPs	<input type="checkbox"/>	<input type="checkbox"/>	<input type="checkbox"/>	
<b>“Supporting calculations and measurements” and “Plan Drawings”</b>				<b>D</b>
<b>General</b>				
Plan Drawings meet standards in Appendix D	<input type="checkbox"/>	<input type="checkbox"/>	<input type="checkbox"/>	
Standard Notes added to plan drawings	<input type="checkbox"/>	<input type="checkbox"/>	<input type="checkbox"/>	
Appropriate Optional Notes added to plan drawings	<input type="checkbox"/>	<input type="checkbox"/>	<input type="checkbox"/>	
Grading Standards added to plan drawings	<input type="checkbox"/>	<input type="checkbox"/>	<input type="checkbox"/>	
<b>Site Access (Chapter 3)</b>				<b>D</b>
Rock Construction Entrances provided where needed	<input type="checkbox"/>	<input type="checkbox"/>	<input type="checkbox"/>	
Standard Construction Detail # 3-1 and/or 3-2 provided	<input type="checkbox"/>	<input type="checkbox"/>	<input type="checkbox"/>	
Temporary and Permanent Access Roads shown	<input type="checkbox"/>	<input type="checkbox"/>	<input type="checkbox"/>	
Standard Construction Detail # 3-3 and/or 3-4 provided	<input type="checkbox"/>	<input type="checkbox"/>	<input type="checkbox"/>	
Broad-based Dips used on active haul roads	<input type="checkbox"/>	<input type="checkbox"/>	<input type="checkbox"/>	
Standard Construction Detail # 3-6 and/or 3-7 provided	<input type="checkbox"/>	<input type="checkbox"/>	<input type="checkbox"/>	
Spacing complies with Table 3.2	<input type="checkbox"/>	<input type="checkbox"/>	<input type="checkbox"/>	
Open-top Culverts used on active haul roads	<input type="checkbox"/>	<input type="checkbox"/>	<input type="checkbox"/>	
Standard Construction Detail #3-8 provided	<input type="checkbox"/>	<input type="checkbox"/>	<input type="checkbox"/>	
Water Deflectors used on haul roads	<input type="checkbox"/>	<input type="checkbox"/>	<input type="checkbox"/>	
Standard Construction Detail #3-9 provided	<input type="checkbox"/>	<input type="checkbox"/>	<input type="checkbox"/>	
Ditch Relief Culverts used on haul roads	<input type="checkbox"/>	<input type="checkbox"/>	<input type="checkbox"/>	
Standard Construction Detail #3-10 provided	<input type="checkbox"/>	<input type="checkbox"/>	<input type="checkbox"/>	
Spacing Complies with Table 3.3	<input type="checkbox"/>	<input type="checkbox"/>	<input type="checkbox"/>	
Turnouts provided where needed on haul roads	<input type="checkbox"/>	<input type="checkbox"/>	<input type="checkbox"/>	
Compost Filter Sock Trap provided where needed	<input type="checkbox"/>	<input type="checkbox"/>	<input type="checkbox"/>	
Temporary Stream Crossings provided where needed	<input type="checkbox"/>	<input type="checkbox"/>	<input type="checkbox"/>	
Standard Construction Detail # 3-12-14 provided	<input type="checkbox"/>	<input type="checkbox"/>	<input type="checkbox"/>	
Figure 3.4 provided for temporary bridges	<input type="checkbox"/>	<input type="checkbox"/>	<input type="checkbox"/>	
Temporary Wetland Crossings provided where needed	<input type="checkbox"/>	<input type="checkbox"/>	<input type="checkbox"/>	
Figure 3.5 3.6, or 3.7 provided	<input type="checkbox"/>	<input type="checkbox"/>	<input type="checkbox"/>	
Figure 3.8 provided where Causeway is proposed	<input type="checkbox"/>	<input type="checkbox"/>	<input type="checkbox"/>	
Temporary Bypass System provided for in-stream work	<input type="checkbox"/>	<input type="checkbox"/>	<input type="checkbox"/>	
Figure 3.9, 3.10, 3.11, or 3.12 provided	<input type="checkbox"/>	<input type="checkbox"/>	<input type="checkbox"/>	
Standard Construction Detail #3-15 or Figure 3.13 provided for Cofferdams	<input type="checkbox"/>	<input type="checkbox"/>	<input type="checkbox"/>	
Silt Curtain details comply with Figure 3.14, 3.15, 3.16, or 3.17	<input type="checkbox"/>	<input type="checkbox"/>	<input type="checkbox"/>	
Pumped Water Filter Bags provided where needed	<input type="checkbox"/>	<input type="checkbox"/>	<input type="checkbox"/>	
Standard Construction Detail # 3-16 provided	<input type="checkbox"/>	<input type="checkbox"/>	<input type="checkbox"/>	
Standard Construction Detail #3-17 provided for sump pits	<input type="checkbox"/>	<input type="checkbox"/>	<input type="checkbox"/>	
<b>Sediment Barriers (Chapter 4)</b>				
All sediment barriers are shown on existing level contour	<input type="checkbox"/>	<input type="checkbox"/>	<input type="checkbox"/>	<b>D</b>
Barrier ends extended upslope or tied into constructed berms	<input type="checkbox"/>	<input type="checkbox"/>	<input type="checkbox"/>	<b>D</b>
Sediment barriers avoid concentrated flows	<input type="checkbox"/>	<input type="checkbox"/>	<input type="checkbox"/>	<b>D</b>
Slope lengths comply with Figure 4.2, Figure 4.3 or Table 4.4	<input type="checkbox"/>	<input type="checkbox"/>	<input type="checkbox"/>	<b>D</b>
Typical details are provided for each type of barrier proposed	<input type="checkbox"/>	<input type="checkbox"/>	<input type="checkbox"/>	<b>D</b>



**Complies Deficient N/A**

Details comply with standard details in Chapter 4, including notes	<input type="checkbox"/>	<input type="checkbox"/>	<input type="checkbox"/>	D
Standard Construction Detail #4-3 and/or 4-4, or 4-5 provided for Weighted Sediment Filter Tubes	<input type="checkbox"/>	<input type="checkbox"/>	<input type="checkbox"/>	D
Standard Construction Detail # 4-6 provided	<input type="checkbox"/>	<input type="checkbox"/>	<input type="checkbox"/>	D
Standard Construction Det. #4-11 provided for Sediment Filter Log	<input type="checkbox"/>	<input type="checkbox"/>	<input type="checkbox"/>	D
Standard Construction Det. # 4-12 provided for Wood Chip Berm	<input type="checkbox"/>	<input type="checkbox"/>	<input type="checkbox"/>	D
Vegetative Filter Strip complies with Table 4.5	<input type="checkbox"/>	<input type="checkbox"/>	<input type="checkbox"/>	D
Standard E&S Worksheet #1 completed for Compost Filter Socks	<input type="checkbox"/>	<input type="checkbox"/>	<input type="checkbox"/>	N
Standard E&S Worksheet #2 completed for Compost Filter Berms	<input type="checkbox"/>	<input type="checkbox"/>	<input type="checkbox"/>	N
Standard E&S Worksheet #3 completed for Standard Silt Fence	<input type="checkbox"/>	<input type="checkbox"/>	<input type="checkbox"/>	N
Standard E&S Worksheet #4 completed for Reinforced Silt Fence	<input type="checkbox"/>	<input type="checkbox"/>	<input type="checkbox"/>	N
Standard E&S Worksheet #5 completed for Alt. Reinforced SF	<input type="checkbox"/>	<input type="checkbox"/>	<input type="checkbox"/>	N
Standard E&S Worksheet #6 completed for Super Silt Fence	<input type="checkbox"/>	<input type="checkbox"/>	<input type="checkbox"/>	N
Standard E&S Worksheet #7 completed for Straw Bale Barriers	<input type="checkbox"/>	<input type="checkbox"/>	<input type="checkbox"/>	N
Standard E&S Worksheet #8 completed for Rock Filters	<input type="checkbox"/>	<input type="checkbox"/>	<input type="checkbox"/>	N

**Note: Plan preparer may provide the information on the standard worksheets in another format as long as it is present in the narrative and identified as such.**

**Channels (Chapter 6)**

All proposed channels shown and labeled on plan map(s)	<input type="checkbox"/>	<input type="checkbox"/>	<input type="checkbox"/>	D
Channel locations are accessible	<input type="checkbox"/>	<input type="checkbox"/>	<input type="checkbox"/>	D
Conflicts with utility lines, roadways, buildings, cuts & fills avoided	<input type="checkbox"/>	<input type="checkbox"/>	<input type="checkbox"/>	D
Sharp turns and flow obstructions avoided	<input type="checkbox"/>	<input type="checkbox"/>	<input type="checkbox"/>	D
Steep slope problems avoided	<input type="checkbox"/>	<input type="checkbox"/>	<input type="checkbox"/>	D
Temporary crossings provided where needed	<input type="checkbox"/>	<input type="checkbox"/>	<input type="checkbox"/>	D
Diversions located upslope of disturbed areas	<input type="checkbox"/>	<input type="checkbox"/>	<input type="checkbox"/>	D
Diversions and outlet channels discharge to waterways or adequately sized storm sewers	<input type="checkbox"/>	<input type="checkbox"/>	<input type="checkbox"/>	D
Collectors located below disturbed areas	<input type="checkbox"/>	<input type="checkbox"/>	<input type="checkbox"/>	D
Collectors discharge to upslope sides of basins or traps	<input type="checkbox"/>	<input type="checkbox"/>	<input type="checkbox"/>	D
Outlet channels protected from adjacent disturbed areas	<input type="checkbox"/>	<input type="checkbox"/>	<input type="checkbox"/>	D
Positive grade provided throughout length of channel	<input type="checkbox"/>	<input type="checkbox"/>	<input type="checkbox"/>	D
Channel bed slopes consistent with those used in calculations	<input type="checkbox"/>	<input type="checkbox"/>	<input type="checkbox"/>	D
Drainage areas are maximums for life of each channel	<input type="checkbox"/>	<input type="checkbox"/>	<input type="checkbox"/>	D
Typical detail provided for each channel shape and lining	<input type="checkbox"/>	<input type="checkbox"/>	<input type="checkbox"/>	D
Manufacturer's installation & stapling details provided	<input type="checkbox"/>	<input type="checkbox"/>	<input type="checkbox"/>	D
All critical dimensions specified	<input type="checkbox"/>	<input type="checkbox"/>	<input type="checkbox"/>	D
Dimensions and linings consistent with those in calculations	<input type="checkbox"/>	<input type="checkbox"/>	<input type="checkbox"/>	D
Temporary liners provided for vegetated channels	<input type="checkbox"/>	<input type="checkbox"/>	<input type="checkbox"/>	D
Underlayment specified for riprap channels	<input type="checkbox"/>	<input type="checkbox"/>	<input type="checkbox"/>	D
Transition zones identified (change in lining)	<input type="checkbox"/>	<input type="checkbox"/>	<input type="checkbox"/>	D
No rock filters or check dams during earthmoving operations	<input type="checkbox"/>	<input type="checkbox"/>	<input type="checkbox"/>	D
Peak flow calculations provided for all channels	<input type="checkbox"/>	<input type="checkbox"/>	<input type="checkbox"/>	N
Standard E&S Worksheet #s 9 and 10 used for Rational Equation	<input type="checkbox"/>	<input type="checkbox"/>	<input type="checkbox"/>	N
Runoff coefficients consistent with Table 5.2	<input type="checkbox"/>	<input type="checkbox"/>	<input type="checkbox"/>	N
Weighted coefficients used for mixed cover drainage areas	<input type="checkbox"/>	<input type="checkbox"/>	<input type="checkbox"/>	N
2-Yr/1-Hr storm used for temporary channels	<input type="checkbox"/>	<input type="checkbox"/>	<input type="checkbox"/>	N
5-Yr/1-Hr storm used for temps in special protection	<input type="checkbox"/>	<input type="checkbox"/>	<input type="checkbox"/>	N
10-Yr/1-Hr storm used for permanent channels	<input type="checkbox"/>	<input type="checkbox"/>	<input type="checkbox"/>	N
Overland flow $\leq$ 150 feet	<input type="checkbox"/>	<input type="checkbox"/>	<input type="checkbox"/>	N
Shallow concentrated flow consistent with Figure 5.1	<input type="checkbox"/>	<input type="checkbox"/>	<input type="checkbox"/>	N

	Complies	Deficient	N/A	
Standard E&S Worksheet # 11 completed properly	<input type="checkbox"/>	<input type="checkbox"/>	<input type="checkbox"/>	N
All channels addressed, including outlet channels for basins and traps	<input type="checkbox"/>	<input type="checkbox"/>	<input type="checkbox"/>	N
Multipliers (1.6, 2.25, 2.75) used properly	<input type="checkbox"/>	<input type="checkbox"/>	<input type="checkbox"/>	N
Significant changes in channel bed slope addressed	<input type="checkbox"/>	<input type="checkbox"/>	<input type="checkbox"/>	N
Manning's "n" adjusted for flow conditions	<input type="checkbox"/>	<input type="checkbox"/>	<input type="checkbox"/>	N
$Q \geq Q_r$	<input type="checkbox"/>	<input type="checkbox"/>	<input type="checkbox"/>	N
$D \geq d +$ minimum required freeboard	<input type="checkbox"/>	<input type="checkbox"/>	<input type="checkbox"/>	N
Flow width:flow depth ratios $\leq 12$ w:1 d	<input type="checkbox"/>	<input type="checkbox"/>	<input type="checkbox"/>	N
$V \leq V_a$	<input type="checkbox"/>	<input type="checkbox"/>	<input type="checkbox"/>	N
$\tau_d \leq \tau_a$	<input type="checkbox"/>	<input type="checkbox"/>	<input type="checkbox"/>	N
2 sets of calculations provided for vegetated channels, one for temporary liner and one for vegetated condition	<input type="checkbox"/>	<input type="checkbox"/>	<input type="checkbox"/>	N

**Note: Plan preparer may provide the information on the standard worksheets in another format as long as it is present in the narrative and identified as such.**

### Sediment Basins (Chapter 7)

All proposed sediment basins shown and labeled on plan map(s)	<input type="checkbox"/>	<input type="checkbox"/>	<input type="checkbox"/>	D
Basin locations are accessible	<input type="checkbox"/>	<input type="checkbox"/>	<input type="checkbox"/>	D
Conflicts with utility lines, roadways, buildings, cuts & fills avoided	<input type="checkbox"/>	<input type="checkbox"/>	<input type="checkbox"/>	D
Steep slope problems avoided	<input type="checkbox"/>	<input type="checkbox"/>	<input type="checkbox"/>	D
Basins located below disturbed areas	<input type="checkbox"/>	<input type="checkbox"/>	<input type="checkbox"/>	D
Stream channels and wetlands avoided	<input type="checkbox"/>	<input type="checkbox"/>	<input type="checkbox"/>	D
Drainage areas are maximums for life of each basin	<input type="checkbox"/>	<input type="checkbox"/>	<input type="checkbox"/>	D
Construction Detail provided for each basin	<input type="checkbox"/>	<input type="checkbox"/>	<input type="checkbox"/>	D
Interior and exterior contours provided on each detail	<input type="checkbox"/>	<input type="checkbox"/>	<input type="checkbox"/>	D
Principal and emergency spillway locations shown	<input type="checkbox"/>	<input type="checkbox"/>	<input type="checkbox"/>	D
All proposed baffles, silt curtains, and forebays shown	<input type="checkbox"/>	<input type="checkbox"/>	<input type="checkbox"/>	D
Sediment clean-out stake location shown	<input type="checkbox"/>	<input type="checkbox"/>	<input type="checkbox"/>	D
Bottom elevation above seasonal high water table, adjacent wetlands, or perennial stream	<input type="checkbox"/>	<input type="checkbox"/>	<input type="checkbox"/>	D
Required flow lengths, turbidity barrier or forebay provided	<input type="checkbox"/>	<input type="checkbox"/>	<input type="checkbox"/>	D
Typical cross-section provided for each type of principal spillway	<input type="checkbox"/>	<input type="checkbox"/>	<input type="checkbox"/>	D
All critical dimensions and elevations shown	<input type="checkbox"/>	<input type="checkbox"/>	<input type="checkbox"/>	D
Sediment clean-out elevation $\geq 1$ ft above basin bottom	<input type="checkbox"/>	<input type="checkbox"/>	<input type="checkbox"/>	D
18" permanent pool provided where needed	<input type="checkbox"/>	<input type="checkbox"/>	<input type="checkbox"/>	D
Dimensions and elevations consistent with those in calcs	<input type="checkbox"/>	<input type="checkbox"/>	<input type="checkbox"/>	D
$Z1 + Z2 \geq 5$	<input type="checkbox"/>	<input type="checkbox"/>	<input type="checkbox"/>	D
$Z1$ and $Z2 \geq 3$ for permanent basin	<input type="checkbox"/>	<input type="checkbox"/>	<input type="checkbox"/>	D
Embankment top width $\geq 8$ feet	<input type="checkbox"/>	<input type="checkbox"/>	<input type="checkbox"/>	D
Key trench and anti-seep collars shown	<input type="checkbox"/>	<input type="checkbox"/>	<input type="checkbox"/>	D
Impervious core shown	<input type="checkbox"/>	<input type="checkbox"/>	<input type="checkbox"/>	D
Typical Detail provided for each type of principal spillway	<input type="checkbox"/>	<input type="checkbox"/>	<input type="checkbox"/>	D
All critical dimensions and elevations shown	<input type="checkbox"/>	<input type="checkbox"/>	<input type="checkbox"/>	D
Dimensions and elevations consistent with those in calcs	<input type="checkbox"/>	<input type="checkbox"/>	<input type="checkbox"/>	D
Standard Construction Detail # 7-6 provided	<input type="checkbox"/>	<input type="checkbox"/>	<input type="checkbox"/>	D
Typical provided for anti-seep collars	<input type="checkbox"/>	<input type="checkbox"/>	<input type="checkbox"/>	D
Typical provided for outlet barrel in concrete bed	<input type="checkbox"/>	<input type="checkbox"/>	<input type="checkbox"/>	D
Typical filter diaphragm detail provided where needed	<input type="checkbox"/>	<input type="checkbox"/>	<input type="checkbox"/>	D
Standard Construction Detail #7-12 provided where needed	<input type="checkbox"/>	<input type="checkbox"/>	<input type="checkbox"/>	D
Standard Construction Detail #7-13 provided where needed	<input type="checkbox"/>	<input type="checkbox"/>	<input type="checkbox"/>	D

	Complies	Deficient	N/A	
Skimmer Details provided	<input type="checkbox"/>	<input type="checkbox"/>	<input type="checkbox"/>	D
Standard Construction Detail #7-1 provided	<input type="checkbox"/>	<input type="checkbox"/>	<input type="checkbox"/>	D
Standard Construction Detail #7-2, 7-3 and 7-4 provided	<input type="checkbox"/>	<input type="checkbox"/>	<input type="checkbox"/>	D
Orifice diameter consistent with Figure 7.2	<input type="checkbox"/>	<input type="checkbox"/>	<input type="checkbox"/>	D
Emergency spillway detail(s) provided	<input type="checkbox"/>	<input type="checkbox"/>	<input type="checkbox"/>	D
Protective liner extends beyond toe of embankment	<input type="checkbox"/>	<input type="checkbox"/>	<input type="checkbox"/>	D
Specs provided for embankment materials and compaction	<input type="checkbox"/>	<input type="checkbox"/>	<input type="checkbox"/>	D
Baffle, silt curtain, forebay detail provided	<input type="checkbox"/>	<input type="checkbox"/>	<input type="checkbox"/>	D
Cleanout stake detail provided	<input type="checkbox"/>	<input type="checkbox"/>	<input type="checkbox"/>	D
Basin dewatering device detail provided	<input type="checkbox"/>	<input type="checkbox"/>	<input type="checkbox"/>	D
Basins discharge to surface waters or approved alternative	<input type="checkbox"/>	<input type="checkbox"/>	<input type="checkbox"/>	D
Standard E&S Worksheet #12 properly completed	<input type="checkbox"/>	<input type="checkbox"/>	<input type="checkbox"/>	N
Total storage volume $\geq$ Total required storage volume	<input type="checkbox"/>	<input type="checkbox"/>	<input type="checkbox"/>	N
Justification exists for all storage volume reductions	<input type="checkbox"/>	<input type="checkbox"/>	<input type="checkbox"/>	N
Proper dewatering time provided	<input type="checkbox"/>	<input type="checkbox"/>	<input type="checkbox"/>	N
Proper total basin discharge capacity provided	<input type="checkbox"/>	<input type="checkbox"/>	<input type="checkbox"/>	N
Principal spillway discharge capacity $\geq$ 10 Yr./1 Hr storm	<input type="checkbox"/>	<input type="checkbox"/>	<input type="checkbox"/>	N
If not discharging to a surface water, calcs provided to show accelerated erosion not a problem	<input type="checkbox"/>	<input type="checkbox"/>	<input type="checkbox"/>	N
Standard E&S Worksheet #13 properly completed	<input type="checkbox"/>	<input type="checkbox"/>	<input type="checkbox"/>	N
Elevation 4 is at least 0.5 ft above Elevation 3	<input type="checkbox"/>	<input type="checkbox"/>	<input type="checkbox"/>	N
Elevation 6 is at least 2.0 ft above Elevation 5	<input type="checkbox"/>	<input type="checkbox"/>	<input type="checkbox"/>	N
Elevation 6 is at least 1.0 ft above Elevation 5 with Discharge capacity for 100-year storm (on Worksheet #12)	<input type="checkbox"/>	<input type="checkbox"/>	<input type="checkbox"/>	N
Required flow length:width ratio at Elevation 3 provided	<input type="checkbox"/>	<input type="checkbox"/>	<input type="checkbox"/>	N
Emergency spillway provided	<input type="checkbox"/>	<input type="checkbox"/>	<input type="checkbox"/>	N
Standard E&S Worksheet #14 properly completed	<input type="checkbox"/>	<input type="checkbox"/>	<input type="checkbox"/>	N
Storage volume at water surface elevation equal to top of settling volume is $\geq$ "Total Storage Volume Provided" on E&S Worksheet #12	<input type="checkbox"/>	<input type="checkbox"/>	<input type="checkbox"/>	N
Storage volume at water surface elevation equal to top of sediment storage volume $\geq$ "Required Sediment Storage Volume" on E&S Worksheet #12	<input type="checkbox"/>	<input type="checkbox"/>	<input type="checkbox"/>	N
Standard E&S Worksheet #15 properly completed	<input type="checkbox"/>	<input type="checkbox"/>	<input type="checkbox"/>	N
Top elevation = Top of dewatering zone	<input type="checkbox"/>	<input type="checkbox"/>	<input type="checkbox"/>	N
Bottom elevation = Top of sediment storage zone	<input type="checkbox"/>	<input type="checkbox"/>	<input type="checkbox"/>	N
Diagonal symmetry evident	<input type="checkbox"/>	<input type="checkbox"/>	<input type="checkbox"/>	N
Standard E&S Worksheet #16 properly completed	<input type="checkbox"/>	<input type="checkbox"/>	<input type="checkbox"/>	N
Figure 7.2 provided with dewatering volume and skimmer orifice size plotted	<input type="checkbox"/>	<input type="checkbox"/>	<input type="checkbox"/>	N
Dewatering time measured from top of dewatering zone to top of sediment storage zone	<input type="checkbox"/>	<input type="checkbox"/>	<input type="checkbox"/>	N
Standard E&S Worksheet #17 properly completed	<input type="checkbox"/>	<input type="checkbox"/>	<input type="checkbox"/>	N
Orifice flow is calculated for flow into top of riser	<input type="checkbox"/>	<input type="checkbox"/>	<input type="checkbox"/>	N
Principal spillway capacity is lesser of riser and barrel	<input type="checkbox"/>	<input type="checkbox"/>	<input type="checkbox"/>	N
Total discharge capacity $\geq$ Required discharge capacity	<input type="checkbox"/>	<input type="checkbox"/>	<input type="checkbox"/>	N
Standard E&S Worksheet #18 properly completed	<input type="checkbox"/>	<input type="checkbox"/>	<input type="checkbox"/>	N
Lf is 1.1 X Ls for temp basin & 1.15 X Ls for perm. basin	<input type="checkbox"/>	<input type="checkbox"/>	<input type="checkbox"/>	N
Downstream analysis OK	<input type="checkbox"/>	<input type="checkbox"/>	<input type="checkbox"/>	N

**Note: Plan preparer may provide the information on the standard worksheets in another format as long as it is present in the narrative and identified as such.**

**Sediment Traps (Chapter 8)**

	Complies	Deficient	N/A	
All proposed traps shown on plan map(s)	<input type="checkbox"/>	<input type="checkbox"/>	<input type="checkbox"/>	D
Spillway locations shown	<input type="checkbox"/>	<input type="checkbox"/>	<input type="checkbox"/>	D
Trap locations are accessible	<input type="checkbox"/>	<input type="checkbox"/>	<input type="checkbox"/>	D
Conflicts with utility lines, roadways, buildings, cuts & fills avoided	<input type="checkbox"/>	<input type="checkbox"/>	<input type="checkbox"/>	D
Steep slope problems avoided	<input type="checkbox"/>	<input type="checkbox"/>	<input type="checkbox"/>	D
Traps located below disturbed areas	<input type="checkbox"/>	<input type="checkbox"/>	<input type="checkbox"/>	D
Stream channels and wetlands avoided	<input type="checkbox"/>	<input type="checkbox"/>	<input type="checkbox"/>	D
Drainage areas are maximums for life of each trap	<input type="checkbox"/>	<input type="checkbox"/>	<input type="checkbox"/>	D
Construction Detail provided for each irregular-shaped trap	<input type="checkbox"/>	<input type="checkbox"/>	<input type="checkbox"/>	D
Interior and exterior contours provided for such traps	<input type="checkbox"/>	<input type="checkbox"/>	<input type="checkbox"/>	D
Bottom elevation above seasonal high water table, adjacent wetlands, or perennial stream	<input type="checkbox"/>	<input type="checkbox"/>	<input type="checkbox"/>	D
Required flow lengths, turbidity barrier or forebay provided	<input type="checkbox"/>	<input type="checkbox"/>	<input type="checkbox"/>	D
Compost sock trap details provided and comply with SCD #3-11	<input type="checkbox"/>	<input type="checkbox"/>	<input type="checkbox"/>	D
Typical cross-section provided for each type of trap	<input type="checkbox"/>	<input type="checkbox"/>	<input type="checkbox"/>	D
All critical dimensions and elevations shown	<input type="checkbox"/>	<input type="checkbox"/>	<input type="checkbox"/>	D
Dimensions and elevations consistent with those in calcs	<input type="checkbox"/>	<input type="checkbox"/>	<input type="checkbox"/>	D
Sediment clean-out elevation $\geq$ 1 ft above trap bottom	<input type="checkbox"/>	<input type="checkbox"/>	<input type="checkbox"/>	D
Typical Detail provided for each type of spillway	<input type="checkbox"/>	<input type="checkbox"/>	<input type="checkbox"/>	D
All critical dimensions and elevations shown	<input type="checkbox"/>	<input type="checkbox"/>	<input type="checkbox"/>	D
Dimensions and elevations consistent with those in calcs	<input type="checkbox"/>	<input type="checkbox"/>	<input type="checkbox"/>	D
Skimmer details provided where needed	<input type="checkbox"/>	<input type="checkbox"/>	<input type="checkbox"/>	D
Standard Construction Detail # 7-1 provided	<input type="checkbox"/>	<input type="checkbox"/>	<input type="checkbox"/>	D
Standard Construction Details #7-2, 7-3 and 7-4 provided	<input type="checkbox"/>	<input type="checkbox"/>	<input type="checkbox"/>	D
Orifice diameter consistent with Figure 7.2	<input type="checkbox"/>	<input type="checkbox"/>	<input type="checkbox"/>	D
Specs provided for embankment materials and compaction	<input type="checkbox"/>	<input type="checkbox"/>	<input type="checkbox"/>	D
Baffle, silt curtain, forebay detail provided	<input type="checkbox"/>	<input type="checkbox"/>	<input type="checkbox"/>	D
Cleanout stake detail provided	<input type="checkbox"/>	<input type="checkbox"/>	<input type="checkbox"/>	D
Trap Outlet Basin Detail provided	<input type="checkbox"/>	<input type="checkbox"/>	<input type="checkbox"/>	D
Trap Dewatering Device Detail provided	<input type="checkbox"/>	<input type="checkbox"/>	<input type="checkbox"/>	D
Traps Discharge to surface waters or approved alternative	<input type="checkbox"/>	<input type="checkbox"/>	<input type="checkbox"/>	D
Standard E&S Worksheet #17 properly completed	<input type="checkbox"/>	<input type="checkbox"/>	<input type="checkbox"/>	N
Tributary drainage areas do not exceed 5.0 acres	<input type="checkbox"/>	<input type="checkbox"/>	<input type="checkbox"/>	N
Required storage capacity provided	<input type="checkbox"/>	<input type="checkbox"/>	<input type="checkbox"/>	N
2:1 Flow length to width ratio provided at elevation h	<input type="checkbox"/>	<input type="checkbox"/>	<input type="checkbox"/>	N
Embankment spillway width is 2 X # AC or 2 X h	<input type="checkbox"/>	<input type="checkbox"/>	<input type="checkbox"/>	N
Barrel-riser spillway provides 1.5 CFS/AC discharge capacity	<input type="checkbox"/>	<input type="checkbox"/>	<input type="checkbox"/>	N
Correct outlet basin dimensions specified	<input type="checkbox"/>	<input type="checkbox"/>	<input type="checkbox"/>	N
Standard E&S Worksheet #13 provided for irregular shaped traps	<input type="checkbox"/>	<input type="checkbox"/>	<input type="checkbox"/>	N
Downstream analysis OK	<input type="checkbox"/>	<input type="checkbox"/>	<input type="checkbox"/>	N

**Note: Plan preparer may provide the information on the standard worksheets in another format as long as it is present in the narrative and identified as such.**

**Outlet Protection (Chapter 9)**

All temporary and permanent outfalls are shown and labeled	<input type="checkbox"/>	<input type="checkbox"/>	<input type="checkbox"/>	D
Locations are accessible to construction equipment	<input type="checkbox"/>	<input type="checkbox"/>	<input type="checkbox"/>	D
Outlet protection provided for all temporary & permanent outfalls	<input type="checkbox"/>	<input type="checkbox"/>	<input type="checkbox"/>	D
Sufficient space exists to construct outlet protection	<input type="checkbox"/>	<input type="checkbox"/>	<input type="checkbox"/>	D
Discharges are properly oriented	<input type="checkbox"/>	<input type="checkbox"/>	<input type="checkbox"/>	D
Outlet areas properly protected from adjacent disturbed areas	<input type="checkbox"/>	<input type="checkbox"/>	<input type="checkbox"/>	D

	Complies	Deficient	N/A	
Typical Details are provided for all types of outlet protection	<input type="checkbox"/>	<input type="checkbox"/>	<input type="checkbox"/>	D
All critical dimensions and elevations are provided	<input type="checkbox"/>	<input type="checkbox"/>	<input type="checkbox"/>	D
Dimensions and elevations are consistent with calcs	<input type="checkbox"/>	<input type="checkbox"/>	<input type="checkbox"/>	D
Standard E&S Worksheet #18 completed for all riprap aprons	<input type="checkbox"/>	<input type="checkbox"/>	<input type="checkbox"/>	N
Calculations provided for adjusted discharge velocity	<input type="checkbox"/>	<input type="checkbox"/>	<input type="checkbox"/>	N
Apron dimensions conform to Figure 9.3 or 9.4	<input type="checkbox"/>	<input type="checkbox"/>	<input type="checkbox"/>	N
Flow transition mat lengths conform to Figure 9.6	<input type="checkbox"/>	<input type="checkbox"/>	<input type="checkbox"/>	N
Stilling Basin Dimensions conform to Standard Construction Detail 9-4 and Figure 9.7	<input type="checkbox"/>	<input type="checkbox"/>	<input type="checkbox"/>	N
Stilling Well Dimensions conform to Figures 9.8, 9.9, and 9.10	<input type="checkbox"/>	<input type="checkbox"/>	<input type="checkbox"/>	N
Supporting calculations are provided for all other types of outlet protection	<input type="checkbox"/>	<input type="checkbox"/>	<input type="checkbox"/>	N
Downstream stability analysis provided where needed	<input type="checkbox"/>	<input type="checkbox"/>	<input type="checkbox"/>	N
<b>Note: Plan preparer may provide the information on the standard worksheets in another format as long as it is present in the narrative and identified as such.</b>				
<b>Other BMPs</b>				
Waterbars specified on utility line ROWs and abandoned roads	<input type="checkbox"/>	<input type="checkbox"/>	<input type="checkbox"/>	D
Standard Construction Detail # 3-5 provided	<input type="checkbox"/>	<input type="checkbox"/>	<input type="checkbox"/>	D
Spacing complies with Table 3.1	<input type="checkbox"/>	<input type="checkbox"/>	<input type="checkbox"/>	D
Storm sewer inlet protection provided where needed	<input type="checkbox"/>	<input type="checkbox"/>	<input type="checkbox"/>	D
Standard Construction Detail # 4-15 and 4-16 provided for inlet filter bags	<input type="checkbox"/>	<input type="checkbox"/>	<input type="checkbox"/>	D
Standard Construction Detail # 4-17 and 4-18 provided for stone and concrete block inlet protection	<input type="checkbox"/>	<input type="checkbox"/>	<input type="checkbox"/>	D
Standard Construction Detail # 4-19 and 4-20 provided for stone inlet protection	<input type="checkbox"/>	<input type="checkbox"/>	<input type="checkbox"/>	D
Standard Construction Detail # 4-21 provided for alternate type M stone inlet protection	<input type="checkbox"/>	<input type="checkbox"/>	<input type="checkbox"/>	D
Standard Construction Detail # 4-22 provided for type C inlet not at grade	<input type="checkbox"/>	<input type="checkbox"/>	<input type="checkbox"/>	D
Standard Construction Detail # 4-23 provided for type M inlet not at grade	<input type="checkbox"/>	<input type="checkbox"/>	<input type="checkbox"/>	D
Erosion Control Blanketing Locations shown on map(s)	<input type="checkbox"/>	<input type="checkbox"/>	<input type="checkbox"/>	D
Complete installation detail(s) provided	<input type="checkbox"/>	<input type="checkbox"/>	<input type="checkbox"/>	D
Typicals provided for on-lot BMPs	<input type="checkbox"/>	<input type="checkbox"/>	<input type="checkbox"/>	D
Other BMPs (specify) _____				
Location(s) shown on plan map(s) & labeled	<input type="checkbox"/>	<input type="checkbox"/>	<input type="checkbox"/>	D
Typical Detail provided with all pertinent dimensions and elevations	<input type="checkbox"/>	<input type="checkbox"/>	<input type="checkbox"/>	D
Design calculations	<input type="checkbox"/>	<input type="checkbox"/>	<input type="checkbox"/>	N
<b>Temporary Stabilization</b>				
Seed type	<input type="checkbox"/>	<input type="checkbox"/>	<input type="checkbox"/>	D
Seed rate of application	<input type="checkbox"/>	<input type="checkbox"/>	<input type="checkbox"/>	
Agricultural lime specified at 1 or 2 T/acre	<input type="checkbox"/>	<input type="checkbox"/>	<input type="checkbox"/>	
Fertilizer type and application rate specified	<input type="checkbox"/>	<input type="checkbox"/>	<input type="checkbox"/>	
Mulch type and application rate specified	<input type="checkbox"/>	<input type="checkbox"/>	<input type="checkbox"/>	
Mulch anchoring type and application rate specified	<input type="checkbox"/>	<input type="checkbox"/>	<input type="checkbox"/>	

	Complies	Deficient	N/A	D
<b>Permanent Stabilization</b>				
Topsoil replacement specs provided	<input type="checkbox"/>	<input type="checkbox"/>	<input type="checkbox"/>	
Standard E&S Worksheet # 21 completed on plan drawings	<input type="checkbox"/>	<input type="checkbox"/>	<input type="checkbox"/>	
Seed types suitable for soil and site conditions specified	<input type="checkbox"/>	<input type="checkbox"/>	<input type="checkbox"/>	
Seed rate of application appropriate	<input type="checkbox"/>	<input type="checkbox"/>	<input type="checkbox"/>	
Agricultural lime specified at 6 T/acre or as per soil test	<input type="checkbox"/>	<input type="checkbox"/>	<input type="checkbox"/>	
10-20-20 fertilizer specified at ½ ton/acre or as per soil test	<input type="checkbox"/>	<input type="checkbox"/>	<input type="checkbox"/>	
Mulch type and application rate specified	<input type="checkbox"/>	<input type="checkbox"/>	<input type="checkbox"/>	
Mulch anchoring type and application rate specified	<input type="checkbox"/>	<input type="checkbox"/>	<input type="checkbox"/>	
Blanketing shown in critical areas, steep slopes, & areas of concentrated flow	<input type="checkbox"/>	<input type="checkbox"/>	<input type="checkbox"/>	
Stabilization of non-graded, but unstabilized, areas, including agricultural areas, within the project site boundaries addressed	<input type="checkbox"/>	<input type="checkbox"/>	<input type="checkbox"/>	

**“A maintenance program, which provides for the operation and maintenance of BMPs and the inspection of BMPs on a weekly basis and after each stormwater event, including the repair or replacement of BMPs to ensure effective and efficient operation. The program must provide for completion of a written report documenting each inspection and all BMP repair, or replacement and maintenance activities”**

	Complies	Deficient	N/A	D
<b>Maintenance Information</b>				
All E&S BMPs inspected weekly and after each runoff event	<input type="checkbox"/>	<input type="checkbox"/>	<input type="checkbox"/>	
Plan specifies maintenance of inspection & maintenance logs	<input type="checkbox"/>	<input type="checkbox"/>	<input type="checkbox"/>	
Maximum sediment storage elevation/level in BMPs specified	<input type="checkbox"/>	<input type="checkbox"/>	<input type="checkbox"/>	
Time frames for completing specific maintenance and repairs for each type of BMP proposed.	<input type="checkbox"/>	<input type="checkbox"/>	<input type="checkbox"/>	
Site stabilization repair parameters and directions	<input type="checkbox"/>	<input type="checkbox"/>	<input type="checkbox"/>	
Disposal directions for sediment removed from BMPs	<input type="checkbox"/>	<input type="checkbox"/>	<input type="checkbox"/>	

**“Procedures that ensure that the proper measures for the recycling or disposal of materials associated with or from the project site will be undertaken in accordance with this title”**

	Complies	Deficient	N/A	D
<b>Offsite Waste and Borrow Areas (see Standard notes 10 &amp; 11 in Appendix C)</b>				
Project construction wastes are identified	<input type="checkbox"/>	<input type="checkbox"/>	<input type="checkbox"/>	
Directions for recycling/disposal of construction wastes	<input type="checkbox"/>	<input type="checkbox"/>	<input type="checkbox"/>	
Soil/rock disposal and borrow areas provided with BMPs	<input type="checkbox"/>	<input type="checkbox"/>	<input type="checkbox"/>	
Note on plans regarding clean fill requirements	<input type="checkbox"/>	<input type="checkbox"/>	<input type="checkbox"/>	

**“Identification of naturally occurring geologic formations or soil conditions that may have the potential to cause pollution during earth disturbance activities and include BMPs to avoid or minimize potential pollution and its impacts from the formations”**

	Complies	Deficient	N/A	D
Potential for geologic or soil conditions to cause pollution during construction is addressed	<input type="checkbox"/>	<input type="checkbox"/>	<input type="checkbox"/>	N
Soil sample locations shown on plan maps	<input type="checkbox"/>	<input type="checkbox"/>	<input type="checkbox"/>	D
Instructions for proper handling and/or disposal of all materials that could cause pollution are provided	<input type="checkbox"/>	<input type="checkbox"/>	<input type="checkbox"/>	D
Typical details are provided for proper handling and/or disposal of all such materials	<input type="checkbox"/>	<input type="checkbox"/>	<input type="checkbox"/>	D
The locations of all such materials are clearly shown on the plan maps	<input type="checkbox"/>	<input type="checkbox"/>	<input type="checkbox"/>	D

**“Identification of the potential thermal impacts to surface waters of this Commonwealth from the earth disturbance activity including BMPs to avoid, minimize or mitigate potential pollution from thermal impacts”**

	<b>Complies</b>	<b>Deficient</b>	<b>N/A</b>	
An analysis of how thermal impacts associated with the project will be avoided is provided	<input type="checkbox"/>	<input type="checkbox"/>	<input type="checkbox"/>	N
If thermal impacts cannot be avoided, impacts are minimized	<input type="checkbox"/>	<input type="checkbox"/>	<input type="checkbox"/>	D&N
BMPs provided to mitigate thermal impacts	<input type="checkbox"/>	<input type="checkbox"/>	<input type="checkbox"/>	D&N

**“The E&S Plan shall be planned, designed, and implemented to be consistent with the PCSM Plan under § 102.8 (relating to PCSM requirements). Unless otherwise approved by the Department, the E&S Plan must be separate from the PCSM Plan and labeled “E&S” or “Erosion and Sediment Control Plan” and be the final plan for construction”**

Overall design of project supports managing of stormwater for erosion control during earth disturbance activities	<input type="checkbox"/>	<input type="checkbox"/>	<input type="checkbox"/>	D&N
Erosion control BMPs can be integrated into structural and Non-structural PCSM practices and approaches	<input type="checkbox"/>	<input type="checkbox"/>	<input type="checkbox"/>	D&N

**“Identification of existing and proposed riparian forest buffers”**

Existing and proposed riparian forest buffers are shown on the plan drawings	<input type="checkbox"/>	<input type="checkbox"/>	<input type="checkbox"/>	D
--	--------------------------	--------------------------	--------------------------	---

## **APPENDIX B - STANDARD E&S WORKSHEETS**

The Standard E&S Worksheets should be reproduced and used by plan preparers as a means of recording required design information for the various erosion and sediment control BMPs used in the E&S plan. The worksheets contain tables of dimensions that should be included in the E&S plan narrative. Use of the worksheets ensures that all required information is included. Failure to provide all of the information required by the appropriate worksheet(s) will constitute a plan that is administratively incomplete. These worksheets may not be altered in form or content unless prior approval is obtained from the reviewing agency. Altered worksheets may not be labeled "Standard E&S Worksheet." While data from these worksheets may appear in the Standard Construction Details, the worksheets themselves may not be substituted for the standard details on the plan drawings.





















**STANDARD E&S WORKSHEET # 9**  
**Time of Concentration**

PROJECT NAME: \_\_\_\_\_  
 LOCATION: \_\_\_\_\_  
 PREPARED BY: \_\_\_\_\_ DATE: \_\_\_\_\_  
 CHECKED BY: \_\_\_\_\_ DATE: \_\_\_\_\_

**OVERLAND FLOW:**

$$T_{c(\text{sheet flow})} = \left[ \frac{2(L)(n)}{3(S)^{0.5}} \right]^{0.4673}$$

PATH NUMBER	LENGTH L (FT)	"n" VALUE	AVERAGE SLOPE (S) (ft/ft)	TIME (minutes)

- n**      **Type of Cover**  
 0.02    smooth pavement  
 0.1     bare parched soil  
 0.3     poor grass cover  
 0.4     average grass cover  
 0.8     dense grass cover  
 (L = 150' maximum)

**SHALLOW CONCENTRATED FLOW:**

PATH NUMBER	LENGTH (FT)	TYPE OF COVER	AVERAGE SLOPE(S) (ft/ft)	V (ft/sec)	TIME (minutes)

**CHANNEL FLOW:**

PATH NUMBER	LENGTH (ft)	AREA (sq. ft.)	AVG. SLOPE (S) (ft/ft)	WET'D PERIM (ft)	HYDR. RADIUS (ft)	MANNING'S "n"	V (ft/sec)	CHANNEL TIME (minutes)	T <sub>c</sub> (minutes)

**CHANNEL DIMENSIONS:**

PATH NUMBER	BOTTOM WIDTH (ft)	LEFT SIDE SLOPE (H:V)	RIGHT SIDE SLOPE (H:V)	TOTAL DEPTH (ft)	TOP WIDTH (ft)



**STANDARD E&S WORKSHEET # 11**  
**Channel Design Data**

PROJECT NAME: \_\_\_\_\_  
 LOCATION: \_\_\_\_\_  
 PREPARED BY: \_\_\_\_\_ DATE: \_\_\_\_\_  
 CHECKED BY: \_\_\_\_\_ DATE: \_\_\_\_\_

CHANNEL OR CHANNEL SECTION					
TEMPORARY OR PERMANENT? (T OR P)					
DESIGN STORM (2, 5, OR 10 YR)					
ACRES (AC)					
MULTIPLIER (1.6, 2.25, or 2.75) <sup>1</sup>					
Q <sub>r</sub> (REQUIRED CAPACITY) (CFS)					
Q (CALCULATED AT FLOW DEPTH d) (CFS)					
PROTECTIVE LINING <sup>2</sup>					
n (MANNING'S COEFFICIENT) <sup>2</sup>					
V <sub>a</sub> (ALLOWABLE VELOCITY) (FPS)					
V (CALCULATED AT FLOW DEPTH d) (FPS)					
τ <sub>a</sub> (MAX ALLOWABLE SHEAR STRESS) (LB/FT <sup>2</sup> )					
τ <sub>d</sub> (CALC'D SHEAR STRESS AT FLOW DEPTH d) (LB/FT <sup>2</sup> )					
CHANNEL BOTTOM WIDTH (FT)					
CHANNEL SIDE SLOPES (H:V)					
D (TOTAL DEPTH) (FT)					
CHANNEL TOP WIDTH @ D (FT)					
d (CALCULATED FLOW DEPTH) (FT)					
CHANNEL TOP WIDTH @ FLOW DEPTH d (FT)					
BOTTOM WIDTH: FLOW DEPTH RATIO (12:1 MAX)					
d <sub>50</sub> STONE SIZE (IN)					
A (CROSS-SECTIONAL AREA) (SQ. FT.)					
R (HYDRAULIC RADIUS)					
S (BED SLOPE) <sup>3</sup> (FT/FT)					
S <sub>c</sub> (CRITICAL SLOPE) (FT/FT)					
.7S <sub>c</sub> (FT/FT)					
1.3S <sub>c</sub> (FT/FT)					
STABLE FLOW? (Y/N)					
FREEBOARD BASED ON UNSTABLE FLOW (FT)					
FREEBOARD BASED ON STABLE FLOW (FT)					
MINIMUM REQUIRED FREEBOARD <sup>4</sup> (FT)					
DESIGN METHOD FOR PROTECTIVE LINING <sup>5</sup>					
PERMISSIBLE VELOCITY (V) OR SHEAR STRESS (S)					

1. Use 1.6 for Temporary Channels; 2.25 for Temporary Channels in Special Protection (HQ or EV) Watersheds; 2.75 for Permanent Channels. For Rational Method, enter "N/A" and attach E&S Worksheets 9 and 10. For TR-55 enter "N/A" and attach appropriate Worksheets.
2. Adjust "n" value for changes in channel liner and flow depth. For vegetated channels, provide data for manufactured linings without vegetation and with vegetation in separate columns.
3. Slopes may not be averaged.
4. Minimum Freeboard is 0.5 ft. or ¼ Total Channel Depth, whichever is greater
5. Permissible velocity lining design method is not acceptable for channels with a bed slope of 10% or greater. Shear stress lining design method is required for channels with a bed slope of 10% or greater. Shear stress lining design method may be used for any channel bed slope.

**STANDARD E&S WORKSHEET # 12**  
**Sediment Basin Capacity Requirements**

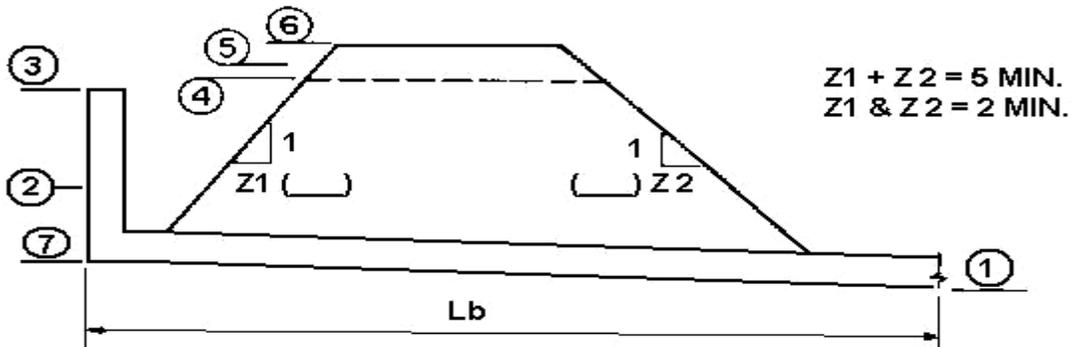
PROJECT NAME: \_\_\_\_\_  
 LOCATION: \_\_\_\_\_  
 PREPARED BY: \_\_\_\_\_ DATE: \_\_\_\_\_  
 CHECKED BY: \_\_\_\_\_ DATE: \_\_\_\_\_

BASIN NUMBER		
PERMANENT OR TEMPORARY BASIN?	(P or T)	
SPECIAL PROTECTION WATERSHED?	(YES OR NO)	
Karst soils?	(YES OR NO)	
(A) MAXIMUM TOTAL DRAINAGE AREA	(AC)	
IS DRAINAGE AREA (A) MORE THAN 10% LARGER THAN THE PRECONSTRUCTION CONDITION?	(YES OR NO)	
(A <sub>1</sub> ) DISTURBED ACRES IN DRAINAGE AREA (AC)		
(I) INITIAL REQ'D DEWATERING ZONE (5,000 X A)	(CF)	
(T) REDUCTION FOR TOP DEWATERING (-700 X A)	(CF)	
(P) REDUCTION FOR PERMANENT POOL (-700 X A)	(CF)	
(L) REDUCTION FOR 4:1 FLOW LENGTH:WIDTH (-350 X A)	(CF)	
(D) REDUCTION FOR 4 TO 7 DAY DEWATERING (- 350 X A)	(CF)	
(S <sub>v</sub> ) REQUIRED DEWATERING ZONE [I - (T+P+L+D)] <sup>1</sup>	(CF)	
(S <sub>d</sub> ) REQUIRED SEDIMENT STORAGE VOLUME (1000 X A <sub>1</sub> )	(CF)	
(S <sub>t</sub> ) TOTAL REQUIRED STORAGE VOLUME (S <sub>v</sub> + S <sub>d</sub> )	(CF)	
TOTAL STORAGE VOLUME PROVIDED (@ ELEV 3) <sup>2</sup>	(CF)	
DEWATERING TIME FOR DEWATERING ZONE	(DAYS)	
REQUIRED DISCHARGE CAPACITY (2 X A)	(CFS) <sup>3</sup>	
PRINCIPAL SPILLWAY TYPE (PERFORATED RISER, SKIMMER, etc.)		
PEAK FLOW FROM 10 YR/24 HR STORM FOR DRAINAGE AREA (A)		
PRINCIPAL SPILLWAY CAPACITY (@ ELEV 5)	(CFS) <sup>4</sup>	
EMERGENCY SPILLWAY CAPACITY (@ ELEV 5)	(CFS) <sup>4</sup>	
TOTAL BASIN DISCHARGE CAPACITY (@ ELEV 5)	(CFS)	
EMERGENCY SPILLWAY PROTECTIVE LINING <sup>5</sup>		
OUTLET TO A SURFACE WATER?	(YES OR NO) <sup>6</sup>	
PEAK FLOW FROM A 100 YR/24 HR STORM FOR DRG. AREA (A)		

- 1 The minimum dewatering zone capacity for sediment basins is (3,600 X A). No reduction is permitted in Special Protection (HQ and EV) Watersheds.
- 2 Total Storage Volume provided at riser crest.
- 3 Or provide calculations to show peak flow from 25 yr./24 hr. storm for area (A) is routed through the basin.
- 4 Provide supporting computations.
- 5 If grass lining is proposed, spillway should be constructed in original ground unless a suitable TRM lining is used. Wherever a TRM is used, riprap should be placed at the bottom of the embankment to prevent scour.
- 6 If no, and basin is permanent or drainage area is more than 10% larger than pre-construction, provide supporting calculations to show accelerated erosion will not result from the proposed discharge. For discharges increasing volume or rate of flow onto a neighboring property prior to entering a surface water, an easement should be obtained prior to plan submittal.

## STANDARD E&S WORKSHEET # 13 Sediment Basin Dimensions and Elevations

PROJECT NAME: \_\_\_\_\_  
 LOCATION: \_\_\_\_\_  
 PREPARED BY: \_\_\_\_\_ DATE: \_\_\_\_\_  
 CHECKED BY: \_\_\_\_\_ DATE: \_\_\_\_\_



BASIN NUMBER		
1. DISCHARGE PIPE ELEVATION (FT)		
2. ELEVATION AT TOP OF SEDIMENT STORAGE ZONE (@ Sd) (FT) (MIN. 1.0' ABOVE ELEVATION 7)		
3. ELEVATION AT TOP OF DEWATERING ZONE (St) (FT) (CREST OF PRINCIPAL SPILLWAY)		
4. EMERGENCY SPILLWAY CREST ELEVATION (FT) (MIN. 0.5' ABOVE ELEVATION 3)		
5. 2 CFS/ACRE OR 25-YR/24-HR FLOW ELEVATION (FT)		
6. TOP OF EMBANKMENT ELEVATION (FT) (MIN. 24" ABOVE ELEVATION 5 OR 12" WITH ROUTED 100-YR/24-HR STORM)		
7. BASIN BOTTOM ELEVATION (FT)		
AVERAGE BOTTOM WIDTH (FT)		
AVERAGE BOTTOM LENGTH (FT)		
(SA <sub>min</sub> ) REQUIRED SURFACE AREA AT ELEVATION 2 (SQ. FT.)		
SURFACE AREA PROVIDED AT ELEVATION 2 (SQ. FT.)		
AVERAGE BASIN WIDTH (W) AT ELEVATION 3 (FT)		
FLOW LENGTH (L) AT ELEVATION 3 (FT)		
FLOW LENGTH:WIDTH RATIO AT ELEVATION 3 (L/W)		
SILT CURTAIN OR FOREBAY? (IF YES, INDICATE WHICH)		
EMBANKMENT TOP WIDTH (FT, 8' MIN.)		
EMBANKMENT SOIL TYPE(S)		
KEY TRENCH DEPTH (FT, 2' MIN.)		
KEY TRENCH WIDTH (FT, 4' MIN.)		
RISER DIAMETER/TYPE (15" MIN.)		
BARREL DIAMETER/TYPE (12" MIN.)		
Lb (BARREL LENGTH) (FT)		
EMERGENCY SPILLWAY WIDTH (FT)		
EMERGENCY SPILLWAY SIDE SLOPES (H:V)		
EMERGENCY SPILLWAY DEPTH (FT)		

For irregular shaped traps, provide stage storage data









**STANDARD E&S WORKSHEET # 17**  
**Sediment Basin Discharge Capacity**

PROJECT NAME: \_\_\_\_\_  
 LOCATION: \_\_\_\_\_  
 PREPARED BY: \_\_\_\_\_ DATE: \_\_\_\_\_  
 CHECKED BY: \_\_\_\_\_ DATE: \_\_\_\_\_

**PRINCIPAL SPILLWAY DISCHARGE CAPACITY**

**BASIN NO:** \_\_\_\_\_

WATER SURFACE ELEVATION <sup>4</sup> (FT)	Flow into Top of TEMPORARY RISER			Flow into Top of PERMANENT RISER			BARREL PIPE FLOW		PRINCIPAL SPILLWAY CAPACITY <sup>3</sup> (CFS)
	HEAD (FT)	ORIFICE FLOW <sup>1</sup> Q(CFS)	WEIR FLOW Q(CFS)	HEAD (FT)	ORIFICE FLOW <sup>1</sup> Q(CFS)	WEIR FLOW Q(CFS)	HEAD <sup>2</sup> (FT)	Q (CFS)	

**EMERGENCY SPILLWAY DISCHARGE CAPACITY**

WATER SURFACE ELEVATION <sup>4</sup> (FT)	EMERGENCY SPILLWAY BOTTOM WIDTH <sup>5</sup> (FT)	TABLE OR C VALUE USED <sup>6</sup>	EMERGENCY SPILLWAY CAPACITY (CFS)	REQUIRED DISCHARGE CAPACITY (CFS)	TOTAL DISCHARGE CAPACITY PROVIDED (CFS) <sup>7</sup>

- Flow into top of riser only (Flow through perforations not included)
- Water surface elevation minus elevation at centerline of pipe outlet
- Least of orifice, weir, or pipe flow (Peak flow from 10 yr/24 hr storm Min.)
- 24" below top of embankment (12" if 100-year storm routed through basin)
- 8 Ft. minimum
- Use Tables 7.5 through 7.8 or equation for broad-crested weir [ $Q = CLH^{1.5}$ , where  $C \leq 2.8$  (MAX)]; for Riprap larger than R-3 or flows less than 1.5' deep adjust C downward]
- Principal Spillway Capacity + Emergency Spillway Capacity



**STANDARD E&S WORKSHEET # 19**  
**Sediment Trap Design Data**

PROJECT NAME: \_\_\_\_\_  
 LOCATION: \_\_\_\_\_  
 PREPARED BY: \_\_\_\_\_ DATE: \_\_\_\_\_  
 CHECKED BY: \_\_\_\_\_ DATE: \_\_\_\_\_

TRAP NUMBER		
DRAINAGE AREA (5 ACRES MAX) (AC)		
REQUIRED CAPACITY (2,000 CF/AC) (CF)		
CAPACITY PROVIDED AT ELEVATION h (CF)		
SOIL TYPES IN DRAINAGE AREA		
REQUIRED SURFACE AREA (5,300 x AC) <sup>1</sup> (SQ. FT)		
* AVERAGE BOTTOM LENGTH (FT)		
* AVERAGE BOTTOM WIDTH (FT)		
* AVERAGE TRAP LENGTH AT ELEVATION h (FT)		
* AVERAGE TRAP WIDTH AT ELEVATION h (FT)		
SURFACE AREA AT ELEVATION h (SQ FT)		
BOTTOM ELEVATION (FT)		
CLEAN-OUT ELEVATION (@ 700 CF/AC) <sup>2</sup> (FT)		
TOP OF EMBANKMENT ELEVATION <sup>3</sup> (FT)		
EMBANKMENT HEIGHT (FT)		
CREST OF SPILLWAY ELEVATION <sup>4</sup> (FT)		
FLOW LENGTH AT ELEVATION h (FT)		
FLOW LENGTH/WIDTH RATIO AT ELEV. h <sup>5</sup> (2:1 MIN)		

- 1 If sandy clays, silty clays, silty clay loams, clay loams, or clays predominate soil types.  
 2 Minimum 12" above bottom of trap  
 3 Minimum 12" above elevation at which 1.5 cfs/acre discharge capacity is provided.  
 4 Minimum 24" above bottom of trap  
 5 4:1 Flow Length:Width ratio required for HQ and EV watersheds.

**EMBANKMENT SPILLWAYS**

OUTLET WIDTH (2 x # ACRES MIN.) <sup>1</sup> (FT)		
SPILLWAY HEIGHT h (FT)		
OUTLET SIDE SLOPES (2H:1V MAX.)		
SPILLWAY OUTSIDE SLOPE Z1 (2 MIN.)		
SPILLWAY INSIDE SLOPE Z2 (2 MIN.)		

1 6 x # Acres Min. if not discharging directly to a waterway

**RISER PIPE SPILLWAYS**

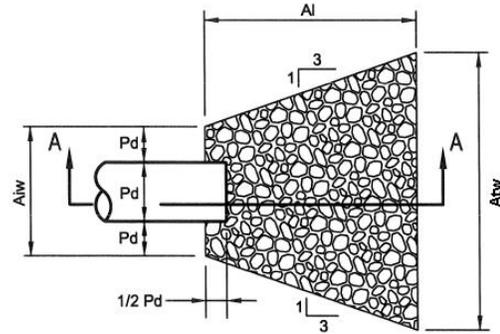
Dr (RISER DIAMETER, 8" MIN.) (IN)		
Db (BARREL DIAMETER, 6" MIN.) (IN)		
SPILLWAY CAPACITY WITH 12" FREEBOARD(CFS)		
BARREL OUTLET ELEVATION (FT)		
MAX WATER SURFACE ELEVATION (@ 1.5 CFS/AC. DISCHARGE) (FT)		

**OUTLET BASIN**

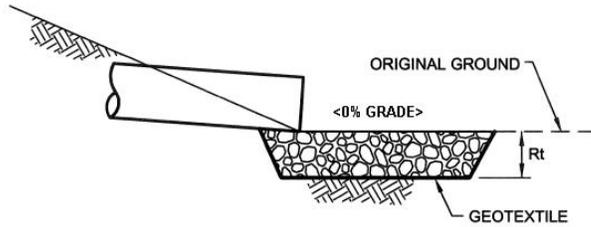
LENGTH (6 Db) (FT)		
WIDTH (3 Db) (FT)		
DEPTH (Db) (FT)		
RIPRAP PROTECTION (R-Size, R-3 min.)		

## STANDARD E&S WORKSHEET # 20 Riprap Apron Outlet Protection

PROJECT NAME: \_\_\_\_\_  
 LOCATION: \_\_\_\_\_  
 PREPARED BY: \_\_\_\_\_ DATE: \_\_\_\_\_  
 CHECKED BY: \_\_\_\_\_ DATE: \_\_\_\_\_



PLAN VIEW



SECTION A - A

NO.	PIPE DIA. Do (in.)	TAIL WATER COND. (Max or Min)	MAN. "n" FOR PIPE	PIPE SLOPE (FT/FT)	Q (CFS)	V* (FPS)	RIPRAP SIZE	Rt (in)	Al (ft)	Aiw (ft)	Atw (ft)

\*:The anticipated velocity (V) should not exceed the maximum permissible shown in Table 6.6 for the proposed riprap protection. Adjust for less than full pipe flow. Use Manning's equation to calculate velocity for pipe slopes  $\geq 0.05$  ft/ft.

**STANDARD E&S WORKSHEET # 21**  
**Temporary and Permanent Vegetative Stabilization Specifications**

PROJECT NAME: \_\_\_\_\_

LOCATION: \_\_\_\_\_

PREPARED BY: \_\_\_\_\_ DATE: \_\_\_\_\_

CHECKED BY: \_\_\_\_\_ DATE: \_\_\_\_\_

SPECIFICATIONS: The Department recommends the use of the Penn State publication, "Erosion Control and Conservation Plantings on Noncropland," as the standard to use for the selection of species, seed specifications, mixtures, liming and fertilizing, time of seeding, and seeding methods. Specifications for these items may also be obtained from PennDOT's Publication # 408, Section 804 or by contacting the applicable county conservation district. Upon selection of a reference, that reference should be used to provide all specifications for seeding, mulching, and soil amendments. The following specification will be used for this project:

(TEMPORARY)                      \*SPECIES: \_\_\_\_\_  
    % PURE LIVE SEED: \_\_\_\_\_ %  
    APPLICATION RATE: \_\_\_\_\_ LB./ACRE  
    FERTILIZER TYPE: \_\_\_\_\_ (X-X-X)  
    FERTILIZER APPL. RATE: \_\_\_\_\_ LB./ACRE  
    LIMING RATE: \_\_\_\_\_ T./ACRE  
    MULCH TYPE: \_\_\_\_\_  
    MULCHING RATE: \_\_\_\_\_ T./ACRE

(PERMANENT)    TOPSOIL PLACEMENT DEPTH: \_\_\_\_\_ IN.  
    \*SPECIES: \_\_\_\_\_  
    % PURE LIVE SEED: \_\_\_\_\_ %  
    APPLICATION RATE: \_\_\_\_\_ LB./ACRE  
    FERTILIZER TYPE: \_\_\_\_\_ (X-X-X)  
    FERTILIZER APPL. RATE: \_\_\_\_\_ LB./ACRE  
    LIMING RATE: \_\_\_\_\_ T./ACRE  
    MULCH TYPE: \_\_\_\_\_  
    MULCHING RATE: \_\_\_\_\_ T./ACRE  
    ANCHOR MATERIAL: \_\_\_\_\_  
    ANCHORING METHOD: \_\_\_\_\_  
    RATE OF ANCHOR MATERIAL APPL.: \_\_\_\_\_ LB./ACRE  
    SEEDING SEASON DATES: \_\_\_\_\_

(PERMANENT - STEEP SLOPE)  
    TOPSOIL PLACEMENT DEPTH: \_\_\_\_\_ IN.  
    \*SPECIES: \_\_\_\_\_  
    % PURE LIVE SEED: \_\_\_\_\_ %  
    APPLICATION RATE: \_\_\_\_\_ LB./ACRE  
    FERTILIZER TYPE: \_\_\_\_\_ (X-X-X)  
    FERTILIZER APPL. RATE: \_\_\_\_\_ LB./ACRE  
    LIMING RATE: \_\_\_\_\_ T./ACRE  
    MULCH TYPE: \_\_\_\_\_  
    MULCHING RATE: \_\_\_\_\_ T./ACRE  
    ANCHOR MATERIAL: \_\_\_\_\_  
    ANCHORING METHOD: \_\_\_\_\_  
    RATE OF ANCHOR MATERIAL APPL.: \_\_\_\_\_ LB./ACRE  
    SEEDING SEASON DATES: \_\_\_\_\_

\*If more than one species is used, indicate application rate for each species.

**Note: This worksheet should be added to the plan drawings.**

**STANDARD E&S WORKSHEET # 22**  
**PLAN PREPARER RECORD OF TRAINING AND EXPERIENCE IN EROSION AND**  
**SEDIMENT POLLUTION CONTROL METHODS AND TECHNIQUES**

**NAME OF PLAN PREPARER:** \_\_\_\_\_

**FORMAL EDUCATION:**

**Name of College or Technical Institute:** \_\_\_\_\_

**Curriculum or Program:** \_\_\_\_\_

**Dates of Attendance: From:** \_\_\_\_\_ **To:** \_\_\_\_\_

**Degree Received** \_\_\_\_\_

**OTHER TRAINING:**

**Name of Training:** \_\_\_\_\_

**Presented By:** \_\_\_\_\_

**Date:** \_\_\_\_\_

**EMPLOYMENT HISTORY:**

**Current Employer:** \_\_\_\_\_

**Telephone:** \_\_\_\_\_

**Former Employer:** \_\_\_\_\_

**Telephone:** \_\_\_\_\_

**RECENT E&S PLANS PREPARED:**

**Name of Project:** \_\_\_\_\_

**County:** \_\_\_\_\_

**Municipality:** \_\_\_\_\_

**Permit Number:** \_\_\_\_\_

**Approving Agency:** \_\_\_\_\_

## APPENDIX C - STANDARD E&S PLAN NOTES

The following notes should be placed on the E&S plan drawings.

1. All earth disturbances, including clearing and grubbing as well as cuts and fills shall be done in accordance with the approved E&S plan. A copy of the approved drawings (stamped, signed and dated by the reviewing agency) must be available at the project site at all times. The reviewing agency shall be notified of any changes to the approved plan prior to implementation of those changes. The reviewing agency may require a written submittal of those changes for review and approval at its discretion.
2. At least 7 days prior to starting any earth disturbance activities, including clearing and grubbing, the owner and/or operator shall invite all contractors, the landowner, appropriate municipal officials, the E&S plan preparer, the PCSM plan preparer, the licensed professional responsible for oversight of critical stages of implementation of the PCSM plan, and a representative from the local conservation district to an on-site preconstruction meeting.
3. At least 3 days prior to starting any earth disturbance activities, or expanding into an area previously unmarked, the Pennsylvania One Call System Inc. shall be notified at 1-800-242-1776 for the location of existing underground utilities.
4. All earth disturbance activities shall proceed in accordance with the sequence provided on the plan drawings. Deviation from that sequence must be approved in writing from the local conservation district or by the Department prior to implementation.
5. Areas to be filled are to be cleared, grubbed, and stripped of topsoil to remove trees, vegetation, roots and other objectionable material.
6. Clearing, grubbing, and topsoil stripping shall be limited to those areas described in each stage of the construction sequence. General site clearing, grubbing and topsoil stripping may not commence in any stage or phase of the project until the E&S BMPs specified by the BMP sequence for that stage or phase have been installed and are functioning as described in this E&S plan.
7. At no time shall construction vehicles be allowed to enter areas outside the limit of disturbance boundaries shown on the plan maps. These areas must be clearly marked and fenced off before clearing and grubbing operations begin.
8. Topsoil required for the establishment of vegetation shall be stockpiled at the location(s) shown on the plan maps(s) in the amount necessary to complete the finish grading of all exposed areas that are to be stabilized by vegetation. Each stockpile shall be protected in the manner shown on the plan drawings. Stockpile heights shall not exceed 35 feet. Stockpile slopes shall be 2H:1V or flatter.
9. Immediately upon discovering unforeseen circumstances posing the potential for accelerated erosion and/or sediment pollution, the operator shall implement appropriate best management practices to minimize the potential for erosion and sediment pollution and notify the local conservation district and/or the regional office of the Department.
10. All building materials and wastes shall be removed from the site and recycled or disposed of in accordance with the Department's Solid Waste Management Regulations at 25 Pa. Code 260.1 et seq., 271.1, and 287.1 et. seq. No building materials or wastes or unused building materials shall be burned, buried, dumped, or discharged at the site.
11. All off-site waste and borrow areas must have an E&S plan approved by the local conservation district or the Department fully implemented prior to being activated.
12. The contractor is responsible for ensuring that any material brought on site is clean fill. Form FP-001 must be retained by the property owner for any fill material affected by a spill or release of a regulated substance but qualifying as clean fill due to analytical testing.
13. All pumping of water from any work area shall be done according to the procedure described in this plan, over undisturbed vegetated areas.
14. Vehicles and equipment may neither enter directly nor exit directly from lots           (specify lot numbers)           onto           (specify road names)          .

15. Until the site is stabilized, all erosion and sediment BMPs shall be maintained properly. Maintenance shall include inspections of all erosion and sediment BMPs after each runoff event and on a weekly basis. All preventative and remedial maintenance work, including clean out, repair, replacement, regrading, reseeding, remulching and renetting must be performed immediately. If the E&S BMPs fail to perform as expected, replacement BMPs, or modifications of those installed will be required.
16. A log showing dates that E&S BMPs were inspected as well as any deficiencies found and the date they were corrected shall be maintained on the site and be made available to regulatory agency officials at the time of inspection.
17. Sediment tracked onto any public roadway or sidewalk shall be returned to the construction site by the end of each work day and disposed in the manner described in this plan. In no case shall the sediment be washed, shoveled, or swept into any roadside ditch, storm sewer, or surface water.
18. All sediment removed from BMPs shall be disposed of in the manner described on the plan drawings.
19. Areas which are to be topsoiled shall be scarified to a minimum depth of 3 to 5 inches — 6 to 12 inches on compacted soils — prior to placement of topsoil. Areas to be vegetated shall have a minimum 4 inches of topsoil in place prior to seeding and mulching. Fill outslopes shall have a minimum of 2 inches of topsoil.
20. All fills shall be compacted as required to reduce erosion, slippage, settlement, subsidence or other related problems. Fill intended to support buildings, structures and conduits, etc. shall be compacted in accordance with local requirements or codes.
21. All earthen fills shall be placed in compacted layers not to exceed 9 inches in thickness.
22. Fill materials shall be free of frozen particles, brush, roots, sod, or other foreign or objectionable materials that would interfere with or prevent construction of satisfactory fills.
23. Frozen materials or soft, mucky, or highly compressible materials shall not be incorporated into fills.
24. Fill shall not be placed on saturated or frozen surfaces.
25. Seeps or springs encountered during construction shall be handled in accordance with the standard and specification for subsurface drain or other approved method.
26. All graded areas shall be permanently stabilized immediately upon reaching finished grade. Cut slopes in competent bedrock and rock fills need not be vegetated. Seeded areas within 50 feet of a surface water, or as otherwise shown on the plan drawings, shall be blanketed according to the standards of this plan.
27. Immediately after earth disturbance activities cease in any area or subarea of the project, the operator shall stabilize all disturbed areas. During non-germinating months, mulch or protective blanketing shall be applied as described in the plan. Areas not at finished grade, which will be reactivated within 1 year, may be stabilized in accordance with the temporary stabilization specifications. Those areas which will not be reactivated within 1 year shall be stabilized in accordance with the permanent stabilization specifications.
28. Permanent stabilization is defined as a minimum uniform, perennial 70% vegetative cover or other permanent non-vegetative cover with a density sufficient to resist accelerated erosion. Cut and fill slopes shall be capable of resisting failure due to slumping, sliding, or other movements.
29. E&S BMPs shall remain functional as such until all areas tributary to them are permanently stabilized or until they are replaced by another BMP approved by the local conservation district or the Department.
30. Upon completion of all earth disturbance activities and permanent stabilization of all disturbed areas, the owner and/or operator shall contact the local conservation district for an inspection prior to removal/conversion of the E&S BMPs.
31. After final site stabilization has been achieved, temporary erosion and sediment BMPs must be removed or converted to permanent post construction stormwater management BMPs. Areas disturbed during removal or conversion of the BMPs shall be stabilized immediately. In order to ensure rapid revegetation of disturbed areas, such removal/conversions are to be done only during the germinating season.
32. Upon completion of all earth disturbance activities and permanent stabilization of all disturbed areas, the owner and/or operator shall contact the local conservation district to schedule a final inspection.



33. Failure to correctly install E&S BMPs, failure to prevent sediment-laden runoff from leaving the construction site, or failure to take immediate corrective action to resolve failure of E&S BMPs may result in administrative, civil, and/or criminal penalties being instituted by the Department as defined in Section 602 of the Pennsylvania Clean Streams Law. The Clean Streams Law provides for up to \$10,000 per day in civil penalties, up to \$10,000 in summary criminal penalties, and up to \$25,000 in misdemeanor criminal penalties for each violation.

### OPTIONAL NOTES

The following notes should be added to plan drawings as applicable.

1. Concrete wash water shall be handled in the manner described on the plan drawings. In no case shall it be allowed to enter any surface waters or groundwater systems.
2. All channels shall be kept free of obstructions including but not limited to fill, rocks, leaves, woody debris, accumulated sediment, excess vegetation, and construction material/wastes.
3. Underground utilities cutting through any active channel shall be immediately backfilled and the channel restored to its original cross-section and protective lining. Any base flow within the channel shall be conveyed past the work area in the manner described in this plan until such restoration is complete.
4. Channels having riprap, Reno mattress, or gabion linings must be sufficiently over-excavated so that the design dimensions will be provided after placement of the protective lining.
5. Sediment basins and/or traps shall be kept free of all construction waste, wash water, and other debris having potential to clog the basin/trap outlet structures and/or pollute the surface waters.
6. Sediment basins shall be protected from unauthorized acts by third parties.
7. Any damage that occurs in whole or in part as a result of basin or trap discharge shall be immediately repaired by the permittee in a permanent manner satisfactory to the municipality, local conservation district, and the owner of the damaged property.
8. Upon request, the applicant or his contractor shall provide an as-built (record drawing) for any sediment basin or trap to the municipal inspector, local conservation district or the Department.
9. Erosion control blanketing shall be installed on all slopes 3H:1V or steeper within 50 feet of a surface water and on all other disturbed areas specified on the plan maps and/or detail sheets.
10. Fill material for embankments shall be free of roots, or other woody vegetation, organic material, large stones, and other objectionable materials. The embankment shall be compacted in maximum \_\_\_\_\_layered lifts at \_\_\_\_\_% density.

## **APPENDIX D - STANDARDS FOR MAPS AND DRAWINGS**

Only those typicals and details pertinent to the E&S Plan should be shown on the plan drawings. Each sheet should be clearly labeled "E&S Plan" or Erosion and Sediment Control Plan." Statements such as "Not for bidding" or "Not for Construction" may not be placed on these drawings. All maps and drawings included in the E&S Plan should be legible. All letters and numbers used on the plans should be readable without magnification. Symbols used should be readily distinguishable from each other, and clutter should be avoided. Information pertinent to the E&S plan as described below should be shown on the plan maps and drawings. All other information should be omitted.

The name of the plan designer along with his/her contact information should be provided.

All maps and drawings should be clearly labeled and dated. Revised maps should have the date of each revision shown. For permitted sites, sufficient space should be provided on the top sheet for the approval stamp and signature of the reviewing agency. The location of this space should be such that the stamp and signature are visible when the map is folded. Maps and drawings having revision dates more recent than the latest approval date will be assumed to be unapproved versions of the E&S plan.

At least one set of maps and drawings submitted to any agency for review should be full size. To facilitate review, it is recommended that linear projects submit a composite plan map showing the entire project, or major portions thereof, proposed contours, E&S BMPs, and staging or work area boundaries.

### **LOCATION MAPS**

A location map that shows the relationship of the project to municipal boundaries and major highways should be provided as part of every E&S plan. For all permitted sites, the location map should be reprinted or copied from the appropriate 7 ½ minute USGS quadrangle map(s). Where these maps are found to be lacking pertinent data, such as new roads, an additional location map (e.g. ADC street map) may be provided. The name(s) of the quadrangle(s) should be included on the location map. For non-permitted sites, any location map found to be inadequate to properly locate the site should be replaced by a photo copy of the USGS map. The location map should be included as an insert on the plan drawings.

### **SOILS MAPS**

Soil boundaries may be plotted on E&S plan maps. Where this option is chosen, care should be taken to avoid error due to enlargement of the soil map from which the boundaries are taken. An acceptable alternative is a legible photocopy of the appropriate soils map from the NRCS website with the project outline clearly shown and identified. The locations of all proposed sediment basins and traps should also be shown.

### **PLAN MAPS**

For the purposes of this section, "Plan Maps" should refer to those maps placed on sheets separate from the plan narrative. Each plan map should have a graphic scale, north arrow, a legend identifying all symbols used, and match lines if more than one sheet is required. Symbols may be identified by use of notes and arrows as long as this does not clutter or otherwise cause confusion. Match lines should identify the adjoining map(s). An overall map should be provided for projects having many adjoining plan maps showing how the individual plan maps fit together.

The scale of the plan map(s) must be large enough to clearly depict the topographic features of the site. Contours should be at an interval that will adequately describe the topography of the site. For permitted sites, a scale of 1 inch equals 50 feet or less, with 2-foot maximum contour intervals should be used unless the reviewing agency agrees that another scale and/or contour interval is appropriate,

such as for extremely steep or extremely gentle slopes. Smaller scale maps and greater contour intervals may be approved for pipeline and utility line projects where warranted. Existing contours should be dashed and lighter in shading than proposed contours. Proposed grading should be shown on the E&S plan map. Proposed contours should be solid and dark. Provide proposed contours for all basins, traps, and channels. At a minimum, contours should be labeled in 10 foot increments. It is recommended that closed contours be labeled as well.

All existing roadways, municipal boundaries, streams, watercourses, wetlands, other surface waters, Federal Emergency Management Agency (FEMA) floodways, structures, utilities, and identifiable landmarks within or in close proximity that could affect or be affected by the project should be shown on the plan map(s). Perennial and intermittent streams (should be identified as such on the plan drawings. Each roadway should be identified, and stream names should be provided. Unnamed streams should be labeled "Unnamed tributary to..." Wherever soil maps indicate the presence of soils having major hydric components or hydric inclusions, a wetland determination should be conducted to find out if wetlands do in fact exist, unless current land use like a parking lot, shopping mall, etc. makes it obvious that no wetlands are present. Wherever it is determined that wetlands exist on site (or off-site but could be affected by the proposed earthmoving) a delineation should be conducted to establish their location and shape. Wetlands should be labeled in a manner consistent with the delineation report. Delineations older than 5 years should not be used on any new plan submittal unless agreed to by the reviewing agency.

The coverage of the map(s) should include sufficient surrounding area so that tributary drainage areas as well as receiving watercourses can be identified and evaluated for resistance to erosion. Where receiving watercourses are located beyond coverage of the plan maps, they may be identified on a USGS topographic map in the narrative or on the plan drawings.

The proposed limits of disturbance should be shown on the plan maps. All proposed earthmoving as well as all proposed E&S BMPs must be located within those boundaries. Any areas within those boundaries that are to remain undisturbed should be clearly delineated. Permitted sites should clearly show the permit boundaries. It cannot be assumed that the limits of disturbance or the property line is the permit boundary. Residential and commercial developments should show lot boundaries with the lot numbers indicated.

All proposed E&S BMPs, including but not necessarily limited to sediment barriers, silt fence, construction entrances, outlet protection, channels, basins, traps, and erosion control blankets, should be shown on the plan maps. Where projects are to be constructed in phases, maps for each phase that show the BMPs that will be present and functioning during that phase should be provided. Each BMP should be clearly labeled. These labels should be consistent with those used on the detail sheets and in the supporting calculations section of the narrative. Wherever channel dimensions or linings change, it should be clearly shown on the plan maps.

Station numbers should be provided for all proposed roadways, pipelines, major utility lines, and stream channel relocations. These station numbers should be consistent with any that are specified in the Construction Sequence.

Sites discharging to special protection watersheds must meet stricter standards and specifications. Where only part of a project is tributary to such a watershed, that portion of the project should be clearly delineated on the plan map(s). Likewise, areas of special concern, such as potentially hazardous materials; areas that are prone to sinkholes, landslides, or mine subsidence; and resource areas that will be protected, such as natural drainage courses, riparian buffers, unusual geologic features, etc. must be clearly shown.

## PLAN DRAWINGS

Each bit of information a contractor will need in order to correctly install, operate, and maintain each of the proposed E&S BMPs should be placed on the plan drawings. This includes the construction sequence; plan notes (Appendix C); construction details and typical; seeding, mulching, and soil amendment specifications; and maintenance instructions. Information not needed by a contractor, such as supporting calculations or manufacturer's test data, should be placed in the narrative, but not on the plan drawings.

A detailed plan view, drawn to scale, should be provided for each proposed sediment basin. This plan view should include proposed contours and show all points of inflow into the basin as well as all outlet structures, such as principal and emergency spillways, with the proposed outlet protection for both inflows and outlets. Other features such as clean-out stakes, and baffles — where needed — should also be shown. Other pertinent information should be shown on typical details such as those provided in this manual.

Any other E & S related structure or BMP (including but not limited to traps, outlet structures, etc.) requiring a scale drawing should also be shown on a plan drawing with all critical dimensions indicated.

Other BMPs for which scale drawings are not required (e.g. channels, stabilized construction entrances, silt fencing, etc.) may be shown on typical drawings. This manual provides Standard Construction Details for many E&S BMPs. They may be placed on the plan drawings to meet this requirement. Care should be taken to include all pertinent data with the Standard Construction Details, including critical dimensions and elevations as well as accompanying notes and tables. The tables should be included where a particular BMP will be used in more than one location with differing specifications for each location. If, for whatever reason, it is necessary to alter a detail from this manual, the term "Standard Construction Detail" may not be used. All details, notes, and tables pertaining to a particular BMP should be located on the same drawing whenever possible. Where it is necessary to place additional information on another drawing, it should be placed on the next drawing, numbered sequentially.

It is recommended that maintenance information be placed near the detail for the BMP for which it is appropriate. However, a separate maintenance schedule should be provided specifying responsibility for conducting inspections, frequency of those inspections, general time frames for completing repairs and instructions for disposing of sediment cleaned from the various BMPs.

Since drawings are often reduced to half sizes for use in the field, the font size and type used should be such that it is still legible after reduction of the drawings to half size.

## APPENDIX E - SOIL USE LIMITATIONS



The following table is a summarization of soil use limitations identified on the NRCS website. This table is intended to help those planning to do earthmoving within the Commonwealth as well as plan designers to become aware of potential hazards that could arise if these soil use limitations are not incorporated into the overall design of the project. Earthmovers and designers are encouraged to consult the NRCS website for additional information about soil limitations and possible remedies.

The Department acknowledges that soil characteristics can and do vary from one location to another. However, a survey of the characteristics described by the NRCS website for the soils in each county found them to be remarkably similar from one county to another. In fact, the limitations varied little from county to county. Obviously, the potential for sinkhole development is pertinent to the areas of Pennsylvania affected by karst topography. Some soils considered prime farmland in some locations are listed as poor sources of topsoil in others. Soils with slope stability problems are more pertinent in areas with steeper terrain. Otherwise, the limitations are fairly consistent.

The information contained in this table as well as that on the NRCS website is most valuable when used as an indicator. It should not be used instead of an on-site investigation. Rather, it should be used to guide such investigations into areas where more data is required, such as wetland determinations, subsurface drilling and sampling, etc.

A quick overview of the limitations reveals some important facts:

1. Every soil in Pennsylvania has significant limitations that need to be addressed in the overall design of any project. Not all limitations will affect every project, but every project will be affected by some limitations.
2. Virtually all Pennsylvania soils (92% of those listed) are susceptible to caving of cut banks. It is imperative that appropriate precautions be taken to safeguard workers during all trenching and excavation operations. All applicable OSHA standards and regulations must be implemented at all times.
3. The vast majority of Pennsylvania soils are corrosive to concrete (82%), uncoated steel (67%), or both. Suitable precautions should be taken to protect all underground pipes, conduits, and storage tanks.
4. Most soils (64%) have relatively shallow depths to saturated zones and/or seasonal high water tables. Unless on-site data indicates otherwise, it should be assumed that excavations into these soils will encounter water and appropriate means provided to handle that water.
5. Most of Pennsylvania's soils (73%) have a relatively low strength. Precautions should be taken to prevent slope failures due to improper construction practices such as over-steepening and overloading of slopes, removal of lateral support, and failure to prevent saturation of slopes. Setbacks should comply with the standards contained in Chapter 16 unless it can be shown that proposed cuts and fills do not pose a hazard to public safety or to surface waters. Also, road fill material will likely need to be imported in areas where soils have low strength.
6. Most of the soils in Pennsylvania (86%) have zones within their profile with slow infiltration rates. Soil tests are strongly recommended for infiltration BMPs proposed as part of a PCSM plan. See Appendix A of Pennsylvania's Stormwater Best Management Practices Manual for additional guidance.
7. Two thirds (68%) of Pennsylvania soils are poor sources of topsoil — at least in some locales. Many have problems with being droughty or too wet. Soil tests are strongly recommended to determine the proper application of soil amendments to promote the growth of the desired vegetation. Wherever soils that are fair or good sources of topsoil may exist on a site, they should

be carefully preserved and stored for later use in restoration. The final design should also address the proper moisture content for the proposed vegetative cover.

8. Frost action is also a serious problem in Pennsylvania (86% of the soils susceptible). Precautions are needed to prevent damage, especially to roadways.
9. Although other limitations, such as shrink-swell and potential sinkholes are found in relatively small percentages of our soils, they tend to be concentrated and therefore quite common in certain regions of the state.

For a more comprehensive list of soil limitations, please log onto the NRCS website at:  
<http://websoilsurvey.nrcs.usda.gov/app/WebSoilSurvey.aspx> .

**TABLE E.1 LIMITATIONS OF PENNSYLVANIA SOILS PERTAINING TO EARTHMOVING PROJECTS (Absence of an X does not mean “No Potential Limitation”)  
 NOTE: THIS IS NOT NECESSARILY AN ALL-INCLUSIVE LIST.**

SOIL NAME	CUTBANKS CAVE	CORROSIVE TO CONCRETE/STEEL	DROUGHTY	EASILY ERODIBLE	FLOODING	DEPTH TO SATURATED ZONE/ SEASONAL HIGH WATER TABLE	HYDRIC/ HYDRIC INCLUSIONS	LOW STRENGTH/ LANDSLIDE PRONE	SLOW PERCOLATION	PIPING	POOR SOURCE OF TOPSOIL	FROST ACTION	SHRINK - SWELL	POTENTIAL SINKHOLE	PONDING	WETNESS
Abbottstown	X	C/S		X		X	X	X	X	X	X	X				X
Aeric Epiaquents	X	C/S	X			X	X				X	X				X
Albrights	X	C/S	X	X		X	X	X	X	X	X	X				X
Alden	X	C/S				X	X	X	X	X	X	X	X		X	X
Aldino	X	C/S				X	X	X	X	X		X				
Allegheny	X	C		X			X	X	X	X	X	X				
Allenwood	X	C/S					X	X	X	X	X	X				
Allis	X	X	X			X	X	X	X	X	X	X	X			
Alluvial Land	X	C/S			X	X	X		X	X	X	X		X		X
Alton	X	C	X						X		X	X				
Alvira	X	C/S	X	X		X	X	X	X	X	X	X				X
Amwell	X	C/S		X		X	X	X	X	X		X				
Andover	X	C/S	X	X		X	X	X	X	X	X	X				X
Aquepts	X	C/S				X	X	X	X	X	X	X			X	X
Aquults	X	C/S		X		X		X	X	X	X	X	X			X
Arents							X									
Arendtsville	X	C	X			X			X	X	X	X				X
Armagh	X	C/S				X	X	X	X	X	X	X	X			X
Arnot	X	C	X	X				X	X		X	X				
Ashton	X				X			X	X	X						
Atherton	X	S				X	X	X	X	X	X	X			X	X
Athol	X	C					X		X	X	X	X				
Atkins	X	C/S			X	X	X	X	X	X	X	X				X
Bagtown	X	C				X	X		X		X	X				X
Baile	X	C/S		X		X	X	X	X	X	X	X	X		X	X
Barbour	X	C	X		X	X	X				X	X				X
Basher	X	C/S			X	X	X	X	X	X	X	X				X

SOIL NAME	CUTBANKS CAVE	CORROSIVE TO CONCRETE/STEEL*	DROUGHTY	EASILY ERODIBLE	FLOODING	DEPTH TO SATURATED ZONE/ SEASONAL HIGH WATER TABLE	HYDRIC/ HYDRIC INCLUSIONS	LOW STRENGTH / LANDSLIDE PRONE	SLOW PERCOLATION	PIPING	POOR SOURCE OF TOPSOIL	FROST ACTION	SHRINK - SWELL	POTENTIAL SINKHOLE	PONDING	WETNESS
Bath	X	C/S				X	X		X		X	X				
Beach & Riverwash	X	C/S				X	X	X		X		X				
Beach Sand	X	C/S			X	X	X		X		X					
Bedington	X	C	X	X			X		X		X	X				
Belmont				X									X			
Beltsville	X	C/S		X		X	X	X	X	X		X				
Benson	X	C	X					X	X	X	X	X				
Berks	X	C	X	X			X		X	X	X					
Bermudian	X	C		X	X	X	X	X		X	X	X				X
Berrien	X	S		X		X	X		X	X		X			X	
Bethesda	X	C/S	X			X	X	X	X		X	X				X
Birdsall	X	C/S				X	X	X	X	X	X	X	X		X	X
Birdsboro	X	C/S		X		X	X		X	X	X	X				X
Blairton	X	C/S		X		X	X	X	X	X	X	X				X
Bowmansville	X	C/S			X	X	X	X	X	X	X	X				X
Braceville	X	C/S	X	X		X	X	X	X	X	X	X				X
Brandywine	X	C	X	X				X	X		X					
Brecknock	X	C	X						X	X	X	X				
Brinkerton	X	C/S	X	X		X	X	X	X	X	X	X	X			X
Brooke	X	S						X	X		X	X	X			
Brownsburg	X	C		X			X	X	X	X	X	X				
Buchanan	X	C/S	X	X		X	X	X	X	X	X	X				X
Buckingham	X	C/S		X		X	X	X	X	X	X	X				X
Bucks	X	C						X	X	X	X	X	X			
Burgin						X		X	X			X	X			
Butlertown	X	C/S		X		X	X	X	X	X		X				
Califon	X	C/S				X		X	X			X				X
Calvert	X	C/S		X		X	X	X	X	X	X	X	X			X
Calvin	X	C	X	X			X			X		X				
Cambridge	X	C/S		X		X	X	X	X	X		X			X	X
Canadice	X	S		X		X	X	X	X		X	X	X		X	X
Canaseraga	X	C/S		X		X		X	X	X		X				X
Caneadea	X	C/S		X		X	X	X	X		X	X	X			X
Canfield	X	C/S		X		X	X	X	X	X		X				X
Carbo	X	S	X	X				X	X		X		X	X		
Catden	X	S				X		X	X			X			X	X
Carlisle	X	S				X	X		X			X			X	X
Catoctin	X	C/S	X								X					
Cattaraugus	X	C	X			X			X		X	X				
Cavode	X	C/S		X		X	X	X	X	X		X	X			X
Cedarcreek	X	C/S	X			X	X	X			X					
Ceres	X	C						X	X		X	X				
Chagrin	X	C		X	X	X	X	X	X	X		X	X		X	X

SOIL NAME	CUTBANKS CAVE	CORROSIVE TO CONCRETE/STEEL*	DROUGHTY	EASILY ERODIBLE	FLOODING	DEPTH TO SATURATED ZONE/ SEASONAL HIGH WATER TABLE	HYDRIC/ HYDRIC INCLUSIONS	LOW STRENGTH / LANDSLIDE PRONE	SLOW PERCOLATION	PIPING	POOR SOURCE OF TOPSOIL	FROST ACTION	SHRINK - SWELL	POTENTIAL SINKHOLE	PONDING	WETNESS
Chalfont	X	C/S		X		X	X	X	X	X	X	X				X
Chavies		C		X	X			X		X		X				
Chenango	X	C	X		X	X	X		X	X	X	X				
Chester	X	C		X				X	X	X	X	X				
Chewacla	X	C/S			X	X	X	X	X	X		X				X
Chili	X	C					X	X	X		X	X				
Chippewa	X	C/S	X	X		X	X	X	X	X		X	X		X	
Chrome	X	C/S	X					X	X		X	X	X			
Clarksburg	X	C/S		X		X	X	X	X	X	X	X	X	X		X
Clearbrook	X	C/S	X				X	X	X	X	X	X	X			
Clymer	X	C	X	X			X	X	X	X	X	X				X
Codorus	X	C/S			X	X	X	X	X	X		X				X
Cokesbury	X					X			X	X		X				
Collamer	X	C/S		X		X	X	X	X	X		X				X
Colonie	X	C	X					X	X		X					
Comly	X	C/S	X	X		X	X			X	X	X				
Comus	X	C		X	X		X	X	X	X		X				
Conestoga	X	C/S						X	X	X		X		X		
Congaree	X	C		X	X		X	X	X	X		X				
Conotton	X	C/S	X	X		X	X	X	X	X	X	X				
Conowingo	X	C/S		X		X		X	X	X		X	X			X
Cookport	X	C/S	X	X		X	X	X	X	X	X	X				X
Covegap	X	C/S							X		X	X		X		
Craigsville	X	C	X		X		X	X			X	X				
Croton	X	C/S		X		X	X	X	X	X	X	X			X	X
Culleoka	X	C		X				X	X	X	X	X				
Culvers	X	C/S	X			X		X	X	X		X				X
Dalton	X	C/S		X		X	X		X	X	X	X			X	
Darien	X	C/S				X		X	X	X	X	X	X			X
DeKalb	X	C	X					X	X	X	X	X				
Delaware	X	C			X		X		X			X				
Deposit	X	C/S	X		X	X	X		X		X					X
Dormont	X	C/S		X		X	X	X	X	X	X	X	X	X		X
Downsville	X	C							X		X	X		X		
Doylestown	X	C/S	X	X		X	X	X	X	X	X	X				X
Drifton	X	C/S		X		X	X	X	X		X	X				
Dryrun	X	C/S		X		X	X		X		X	X				
Duffield	X	C/S		X			X	X	X	X	X		X	X		X
Duncannon	X	C		X				X	X	X		X				
Dunning	X	C/S		X	X	X	X	X	X		X		X	X	X	X
Dystrochrepts	X	C/S	X	X	X	X	X	X	X	X	X	X				
Edgemere	X	C/S				X	X	X	X	X	X	X			X	X
Edgemont	X	C	X				X		X		X	X				



SOIL NAME	CUTBANKS CAVE	CORROSIVE TO CONCRETE/STEEL*	DROUGHTY	EASILY ERODIBLE	FLOODING	DEPTH TO SATURATED ZONE/ SEASONAL HIGH WATER TABLE	HYDRIC/ HYDRIC INCLUSIONS	LOW STRENGTH / LANDSLIDE PRONE	SLOW PERCOLATION	PIPING	POOR SOURCE OF TOPSOIL	FROST ACTION	SHRINK - SWELL	POTENTIAL SINKHOLE	PONDING	WETNESS
Edom	X	S	X	X				X	X	X	X	X	X	X	X	
Elk	X	C/S		X			X	X	X	X						
Elkins	X	c/s			X	X	X	X	X	X	X	X				
Elko	X	C/S	X			X		X	X		X	X				X
Ellery	X	C/S	X			X	X	X	X	X	X	X			X	X
Elliber	X	C	X						X		X	X		X		
Elnora	X	C	X			X			X		X					X
Empyville	X	C	X			X	X		X		X	X				
Erie	X	S	X	X		X	X	X	X	X	X	X			X	X
Ernest	X	C/S		X		X	X	X	X	X	X	X	X			X
Evendale	X	C/S				X	X	X	X	X	X	X	X	X		X
Fairplay	X	S		X	X	X	X	X	X	X	X	X			X	
Fairpoint	X	C/S	X				X	X	X		X	X	X	X		
Fitchville	X	C/S				X	X	X	X	X	X	X	X			X
Fountainville	X	C/S		X		X		X	X	X		X				
Fleetwood	X	C	X					X			X					X
Fluents	X	C/S	X	X	X	X	X			X		X				
Fluvequents	X	C/S	X	X	X	X	X	X		X		X				
Fredon	X	C/S	X	X		X	X	X	X		X	X				X
Freetown	X	C/S				X	X	X				X			X	
Frenchtown	X	C/S		X		X	X	X	X	X	X	X			X	X
Freshwater Marsh	X	S				X	X	X	X		X	X			X	
Funkstown	X	S		X	X	X		X	X	X		X				X
Gageville	X	C/S		X		X		X	X	X	X	X	X			X
Gaila	X	C/S						X	X		X	X				
Gibraltar	X	C/S		X	X	X	X	X	X	X		X				
Gilpin	X	C	X	X			X	X	X	X	X	X				
Ginat	X	C/S		X		X	X	X	X	X	X	X			X	X
Gladstone	X	C		X			X		X			X	X			
Glenelg	X	C		X			X	X	X	X	X	X				X
Gleneyre	X	C/S			X	X	X	X	X	X	X	X			X	X
Glenford	X	C/S				X	X	X	X	X		X	X			
Glenville	X	C/S				X	X	X	X	X	X	X				X
Gresham		X		X			X	X	X	X		X				X
Guernsey	X	C/S		X		X	X	X	X		X	X	X	X		X
Guthrie							X									
Hagerstown	X	S		X		X	X	X	X	X	X	X	X	X		
Halsey	X	C/S		X	X	X	X	X	X	X	X	X				X
Hanover	X	C/S				X	X	X	X	X		X	X			
Harbor	X	C/S				X		X	X			X	X			
Haplaquents							X									
Hartleton	X	C	X					X	X	X	X	X				
Hatboro	X	C/S			X	X	X	X	X	X	X	X				X

SOIL NAME	CUTBANKS CAVE	CORROSIVE TO CONCRETE/STEEL*	DROUGHTY	EASILY ERODIBLE	FLOODING	DEPTH TO SATURATED ZONE/ SEASONAL HIGH WATER TABLE	HYDRIC/ HYDRIC INCLUSIONS	LOW STRENGTH / LANDSLIDE PRONE	SLOW PERCOLATION	PIPING	POOR SOURCE OF TOPSOIL	FROST ACTION	SHRINK - SWELL	POTENTIAL SINKHOLE	PONDING	WETNESS
Haven	X	C	X					X	X			X				
Hazleton	X	C	X	X			X	X	X	X	X	X				
Henrietta	X					X		X	X		X	X			X	
Highfield	X	C	X				X		X		X	X				
Hollinger	X	C						X	X	X		X		X		
Holly	X	C/S			X	X	X	X	X	X	X	X			X	X
Hornell	X	C/S	X	X		X		X	X		X	X	X			X
Howard	X		X	X			X		X		X	X				
Howell	X	C/S		X		X		X		X		X	X			
Hublersburg	X	C/S						X	X	X	X	X	X			
Huntington	X	C			X	X	X	X				X		X		
Hustontown	X	C/S	X			X	X		X	X		X				
Itmann	X	C/S	X					X	X		X	X				
Ivory	X	C/S		X		X	X	X	X	X	X	X	X			
Jimtown	X	C/S				X	X	X			X	X				X
Joanna	X	C					X	X	X	X		X				
Jugtown	X	S			X	X	X	X	X	X		X		X		
Kedron	X	C/S				X	X	X	X	X	X	X				X
Kanona							X									
Kimbles	X	C/S				X	X	X	X		X	X				X
Kingsville	X	C/S	X			X	X		X		X	X			X	X
Kinzua	X	C						X	X		X	X				
Klinesville	X	C/S	X	X			X		X		X	X				
Knauers	X	C/S	X		X	X	X	X	X		X	X			X	X
Kreamer	X	C/S		X		X	X	X	X	X		X		X		
Lackawanna	X	C	X			X	X	X			X	X				X
Laidig	X	C/S	X	X		X	X	X	X	X	X	X				
Lakin	X	C	X						X							
Lamington	X	C/S		X		X	X		X	X	X	X			X	X
Langford	X	S	X	X		X	X	X	X		X	X			X	X
Lansdale	X	C	X					X	X		X	X				
Lantz	X	C/S		X	X	X	X	X	X	X	X	X	X			X
Lawrenceville	X	C/S		X		X	X	X	X	X		X				X
Leck Kill	X	C						X	X	X	X	X				X
Leetonia	X	C	X	X			X				X					
Legore	X	C/S	X					X	X	X	X	X	X			
Lehew	X	C	X						X		X					
Lehigh	X	C/S				X	X		X	X	X	X				X
Lewisberry		C								X	X	X				
Library	X	C/S		X		X	X	X	X		X	X	X	X		X
Lickdale	X	C/S		X		X	X	X	X		X	X	X			
Linden	X	C			X	X	X	X	X	X		X				
Lindside	X	S			X	X	X	X	X	X		X		X		X

SOIL NAME	CUTBANKS CAVE	CORROSIVE TO CONCRETE/ TEEL *	DROUGHTY	EASILY ERODIBLE	FLOODING	DEPTH TO SATURATED ZONE/ SEASONAL HIGH WATER TABLE	HYDRIC/ HYDRIC INCLUSIONS	LOW STRENGTH / LANDSLIDE PRONE	SLOW PERCOLATION	PIPING	POOR SOURCE OF TOPSOIL	FROST ACTION	SHRINK - SWELL	POTENTIAL SINKHOLE	PONDING	WETNESS
Lobdell	X	C/S		X	X	X	X	X	X	X		X	X			X
Lordstown	X	C	X	X				X	X	X		X				
Loudonville	X	C/S						X	X	X		X	X			
Lowell	X	C/S						X	X	X	X	X	X	X		
Luray		X		X		X		X	X	X	X	X	X		X	X
Macove	X	C/S						X	X		X	X				
Mahoning	X	C/S		X		X	X	X	X	X	X	X	X		X	X
Manlius	X	C	X				X		X		X	X				
Manor	X	C		X				X	X	X	X	X				
Mardin	X	S	X	X		X	X	X	X	X		X				X
Markes	X	C/S	X			X		X	X		X	X				X
Matapeake	X	C/S		X			X	X	X		X	X				
Matewan	X	C	X						X		X					
Mattapex	X	C/S		X		X	X	X	X	X		X				
Maurertown	X	C/S		X	X	X	X	X	X	X	X	X	X		X	
Meckesville	X	C/S				X		X	X	X	X	X				X
Medihemists	X	S				X	X	X				X			X	X
Medifibrists	X	S				X	X					X			X	X
Medisaprists		S				X	X	X				X			X	X
Melvin	X	S		X	X	X	X	X	X	X	X	X	X	X	X	X
Mertz	X	C/S								X		X				
Middlebury	X	S			X	X	X		X	X		X	X			
Mill	X	C/S				X	X	X	X	X	X	X	X		X	X
Millheim		C/S		X				X	X	X	X	X				
Miner	X	C/S				X	X	X	X		X	X	X		X	X
Monongahela	X	C/S		X		X	X	X	X	X		X	X			X
Montalto	X	C/S					X	X	X		X	X	X			
Montevallo		C/S	X				X	X			X	X				
Morris	X	C/S	X	X		X	X	X	X		X	X				X
Morrison	X	C		X				X	X			X		X		
Mt. Airy	X	C	X				X				X	X				
Mt. Lucas	X	C/S				X	X	X	X	X	X	X				X
Mt. Zion	X	C/S		X		X	X	X	X	X	X	X	X			
Muck		X			X	X	X			X					X	X
Muck and Peat	X	S				X	X	X	X		X	X	X		X	X
Murrill	X	C/S					X	X	X	X	X	X		X		
Myersville	X	C/S						X	X	X	X	X				
Nanticoke	X	C			X	X	X	X	X	X	X				X	X
Natalie							X									
Neshaminy	X	C/S				X	X	X	X	X	X	X				
Newark	X	S		X	X	X	X	X	X	X	X	X		X		
Nockamixon	X	C/S		X		X	X	X	X	X		X				X
Nolin	X	C			X	X	X	X	X	X				X		

SOIL NAME	CUTBANKS CAVE	CORROSIVE TO CONCRETE/STEEL*	DROUGHTY	EASILY ERODIBLE	FLOODING	DEPTH TO SATURATED ZONE/ SEASONAL HIGH WATER TABLE	HYDRIC/ HYDRIC INCLUSIONS	LOW STRENGTH / LANDSLIDE PRONE	SLOW PERCOLATION	PIPING	POOR SOURCE OF TOPSOIL	FROST ACTION	SHRINK - SWELL	POTENTIAL SINKHOLE	PONDING	WETNESS
Nollville	X	C/S						X	X		X	X	X	X		
Nolo	X	C/S	X			X	X	X	X	X	X	X				X
Norwich	X	C/S	X	X		X	X	X	X		X	X			X	X
Ochrepts	X	C	X						X		X	X				
Onoville	X	C/S	X			X		X	X	X	X	X	X			X
Opequon	X	S	X	X				X	X		X	X	X	X		
Oquaga	X	C	X	X			X		X		X	X				
Orrville	X	C/S			X	X	X	X	X	X	X	X				X
Otego	X	S		X	X	X		X	X	X	X	X				X
Othello	X	C/S				X	X	X	X	X	X	X				X
Ottawa	X	C	X						X			X				
Painesville	X	C/S				X	X		X	X	X	X				X
Palms	X	C/S				X	X	X	X		X	X			X	X
Papakating	X	C/S			X	X	X	X	X	X	X	X			X	X
Parker	X	C	X						X		X	X				
Paupack	X	S				X	X		X			X			X	X
Pecktonville	X	C/S		X		X		X	X		X	X	X	X		
Pekin					X		X			X		X				
Pen Argyl	X	C										X				
Penlaw	X	C/S		X		X	X	X	X	X	X	X	X	X		X
Penn	X	C	X				X	X		X	X	X				
Penn Val	X	C/S							X		X	X				
Pequea	X			X						X	X	X				
Phelps	X	S		X		X	X		X	X	X	X				X
Philo	X	C/S		X	X	X	X	X	X	X	X	X				X
Platea	X	C/S		X		X	X	X	X	X		X				X
Pocono	X	C	X						X		X					
Pope	X	C/S		X	X		X	X	X	X	X	X				
Portville	X	C/S				X	X		X	X	X	X	X			
Potomac	X	C	X		X						X					
Psammets	X	C	X		X	X			X		X					
Purdy	X	C/S		X		X	X	X	X	X	X	X	X			X
Rainsboro	X	X		X		X	X	X	X			X				
Ramsey		C	X						X		X					
Raritan	X	C/S				X	X		X	X	X	X				X
Ravenna		C/S		X		X			X	X	X	X				X
Ravenrock	X	C/S				X			X		X	X				
Rayne	X	C		X				X	X	X	X	X				
Readington	X	C/S		X		X	X	X	X	X	X	X				X
Reaville	X	C/S	X	X		X	X		X	X	X	X				X
Red Hook	X	C/S		X	X	X	X		X	X	X	X				
Rexford	X	C/S	X		X	X	X	X	X	X	X	X				X
Rimer	X	C/S	X	X		X	X		X	X	X	X	X			X

SOIL NAME	CUTBANKS CAVE	CORROSIVE TO CONCRETE/STEEL*	DROUGHTY	EASILY ERODIBLE	FLOODING	DEPTH TO SATURATED ZONE/ SEASONAL HIGH WATER TABLE	HYDRIC/ HYDRIC INCLUSIONS	LOW STRENGTH / LANDSLIDE PRONE	SLOW PERCOLATION	PIPING	POOR SOURCE OF TOPSOIL	FROST ACTION	SHRINK - SWELL	POTENTIAL SINKHOLE	PONDING	WETNESS
Riverhead	X	C	X					X	X		X	X				X
Riverwash							X									
Rohrersville	X	C/S		X		X	X	X	X	X		X	X			X
Rowland	X	C/S		X	X	X	X	X	X	X	X	X				X
Rubble Land											X					
Rushtown	X	C	X						X							
Ryder	X	C/S						X	X	X		X		X		
Sassafras	X	C						X	X			X				
Scio	X	C/S		X		X	X	X	X	X		X				X
Sciotoville	X	C/S		X		X	X	X	X	X		X	X			X
Sebring	X	C/S				X	X	X	X	X	X	X	X		X	X
Sequatchie		X		X						X						
Sheffield	X	C/S				X	X	X	X	X		X			X	
Shelmadine	X	C/S	X			X	X	X	X	X	X	X				
Shelocta	X	C						X	X		X	X				
Shohola	X	C/S	X			X	X	X	X	X	X	X				X
Shongo	X	C/S				X	X	X	X	X	X	X	X			X
Sideling	X	C/S				X			X	X	X	X	X			
Skidmore	X	C	X		X	X	X		X		X					
Sloan	X	S		X	X	X	X	X	X	X	X	X	X			X
Solon	X	C	X					X			X	X				
Stanhope	X	C/S		X	X	X	X	X	X	X	X	X	X			X
Steff					X	X	X	X				X				
Steinsburg	X	C	X						X		X					
Stoney Land											X					
Swanpond	X	S		X		X		X	X		X	X	X			X
Suncook	X	C	X		X		X		X		X					
Swartswood	X	C	X	X		X		X	X	X	X					
Thorndale	X	C/S				X	X	X	X	X	X	X	X	X		X
Thurmont	X	C/S				X		X	X		X	X				
Tilsit	X	C/S		X		X	X	X	X	X						X
Tioga	X	C		X	X	X	X		X							
Timberville	X	C			X			X	X	X	X	X	X			
Titusville	X	C/S		X		X	X	X	X	X		X	X			X
Towhee	X			X		X	X	X	X	X	X	X	X			
Trego	X	C/S		X		X		X	X		X	X	X			
Trumbull	X	C/S		X		X	X	X	X	X	X	X	X		X	X
Tunkhannock	X	C	X				X		X		X					
Tygart	X	C/S		X		X	X	X	X	X	X	X	X			X
Tyler	X	C/S		X		X	X	X	X	X	X	X	X			X
Udifluvents	X	C/S			X	X	X		X	X		X				
Udorthents	X	C/S	X	X				X	X		X	X				
Unadilla	X	C		X			X	X	X	X		X				

SOIL NAME	CUTBANKS CAVE	CORROSIVE TO CONCRETE/STEEL*	DROUGHTY	EASILY ERODIBLE	FLOODING	DEPTH TO SATURATED ZONE/ SEASONAL HIGH WATER TABLE	HYDRIC/ HYDRIC INCLUSIONS	LOW STRENGTH / LANDSLIDE PRONE	SLOW PERCOLATION	PIPING	POOR SOURCE OF TOPSOIL	FROST ACTION	SHRINK - SWELL	POTENTIAL SINKHOLE	PONDING	WETNESS
Ungers	X	C		X				X	X			X				
Upshur	X	C/S	X	X				X	X		X	X	X			
Urbana						X						X				
Valois	X	C					X	X	X		X	X				
Vandergrift	X	C/S		X			X	X	X		X	X	X			X
Vanderlip	X	C	X						X							
Venango	X	C/S		X		X	X	X	X	X	X	X				X
Volusia	X	C/S	X	X		X	X	X	X	X	X	X				
Wallington	X	C/S		X		X	X	X	X	X	X	X				X
Warners		S		X	X	X	X	X	X		X	X			X	X
Washington	X	S				X	X	X	X	X		X	X	X		
Watchung	X	C/S		X		X	X	X	X	X	X	X	X			X
Watson	X	C/S	X			X	X	X	X	X		X	X			
Wauseon	X	C/S				X	X	X	X	X	X	X			X	X
Wayland	X	S		X	X	X	X	X	X	X	X	X			X	X
Wehadkee	X	C/S			X	X		X	X	X		X				X
Weikert	X	C/S	X				X	X	X	X	X	X				
Weinbach	X	C/S		X		X	X	X	X	X	X	X	X			X
Wellsboro	X	C/S	X	X		X	X	X	X	X		X				X
Westmoreland	X	C		X				X	X	X		X				
Weverton	X	C/S	X					X	X		X	X				
Wharton	X	C/S		X		X	X	X	X	X	X	X	X			X
Wheeling	X	C						X	X	X		X				
Whiteford																
Whitwell																
Wick	X	C/S		X	X	X	X	X	X	X	X	X				X
Wickham																
Williamson	X	C/S		X		X	X	X	X	X		X				X
Wiltshire					X					X						
Woodglen																
Woodstown	X	C/S				X		X	X	X	X	X				X
Wooster	X	C		X		X		X	X	X	X	X				
Worsham	X	C/S		X		X	X	X	X	X	X	X	X			
Worth	X	C	X	X		X	X		X	X	X	X				
Wurno	X		X					X	X		X	X		X		
Wurstboro	X	C/S				X	X		X		X	X				
Wyalusing	X	C/S			X	X	X	X	X		X	X				X
Wyoming	X	C	X				X		X		X					
Zipp		X				X	X	X		X	X	X	X			
Zoar	X	C/S				X	X	X	X	X		X	X			

## APPENDIX F - ENERGY DISSIPATERS



PA DEP

Two examples of energy dissipaters are provided in this appendix for informational purposes only. The Department recognizes that there are many other possible design configurations, which could be used with satisfactory results.

Wherever other designs are employed, they should conform to the specifications cited in the reference used. In all such cases, these specifications should be listed in the narrative along with supporting calculations to show that the proposed dissipater meets all design specifications as well as reducing the anticipated discharge velocity to an acceptable level.

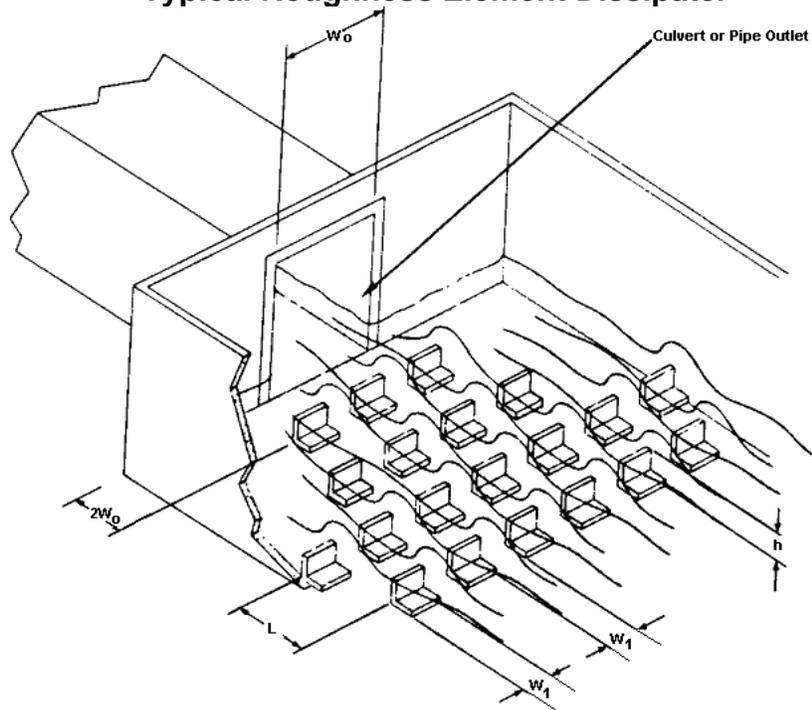
All necessary construction information, such as dimensions, elevations, etc., should be clearly shown on the plan drawings.

For additional information regarding design of energy dissipaters, see Hydraulic Design of Energy Dissipaters for Culverts and Channels, HEC No. 14, U.S. Department of Transportation, Federal Highway Administration. Copies of this publication can be obtained by contacting:

National Technical Information Service  
5285 Port Royal Road  
Springfield, VA 22161  
Telephone (703) 487-4650

ROUGHNESS ELEMENT DISSIPATER - This type of dissipater, shown in Figure F.1, makes use of hydraulic jump to dissipate energy and reduce velocity from a pipe outfall.

**FIGURE F.1  
Typical Roughness Element Dissipater**



USDOT, FHWA HEC 14

**DESIGN LIMITATIONS**

1. Maximum Pipe Diameter ( $W_0$ )  $\leq$  1/4 Downstream Channel Width
2. Slope from Pipe Outfall to end of Dissipater  $\leq$  10 percent
3. Roughness Elements should be anchored sufficiently to withstand the anticipated drag forces. The Anticipated Drag Force ( $F_D$ ) is given by the formula:

$$F_D = 1.94 A_F V_a^2$$

Where:  $A_F$  = Frontal Area of roughness element  
 $V_a$  = Approach Velocity (average velocity in expansion area)

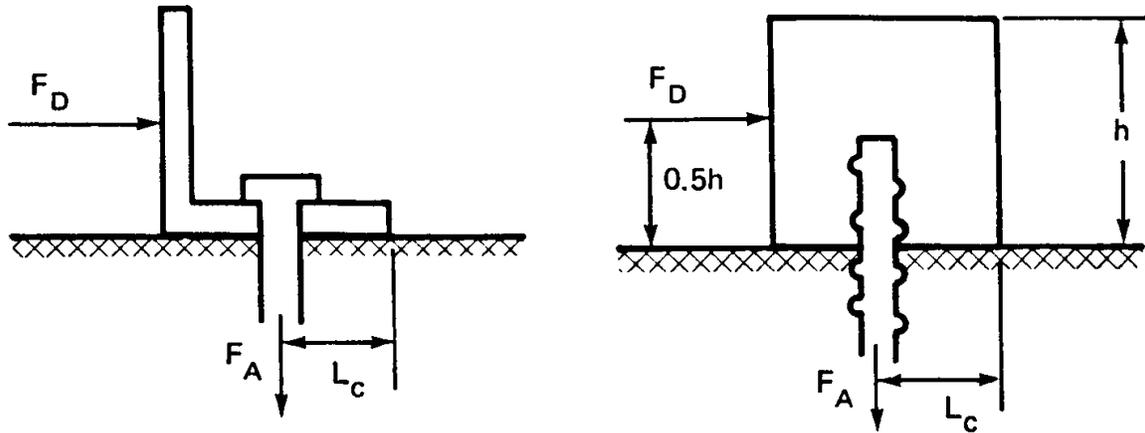
The Required Anchoring Force ( $F_A$ ) can be calculated by the formula:

$$F_A = 0.97 (h/L_C) A_F V_a^2$$

Where:  $h$  = Height of roughness element  
 $L_C$  = Distance from the downstream edge of roughness element to its centroid, as shown in Figure F.2



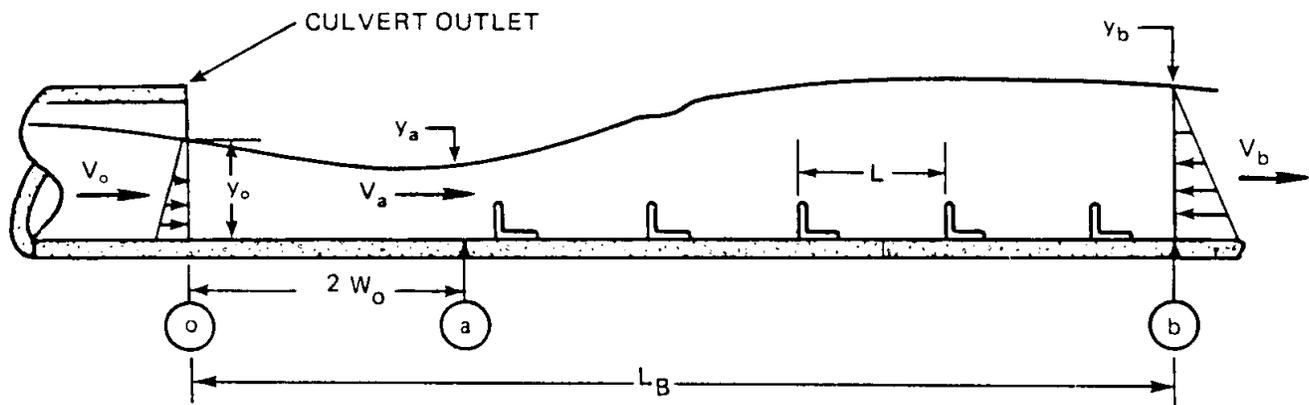
**FIGURE F.2  
Forces Acting on a Roughness Element**



USDOT, FHWA HEC 14

4. Dissipater Width ( $W_D$ )  $\cong$  Downstream Channel Width
5. Roughness elements should be arranged symmetrically about the centerline of the dissipater.
6. The Lateral Spacing ( $W_1$ ) of the elements should be approximately equal to the element width, as shown in Figure F.3.
7.  $W_1/h$  Ratio should be between 2 and 8.
8. At least  $\frac{1}{2}$  of the rows should have elements near the walls of the dissipater.
9. Rows should be staggered.

**FIGURE F.3  
Critical Dimensions Used in Designing Roughness Element Dissipaters**



US DOT, FHWA HEC 14

**DESIGN PROCEDURE** (See Figure F.3 for critical dimensions)

1. Determine the Discharge Flow Depth ( $Y_o$ ) using Figure F.4 or F.5.

2. Determine Discharge Velocity ( $V_o$ ) using Figures F.5 and F.6 or by the equation:

$$V = Q/A$$

Where:  $A$  = Cross-sectional area of the **flow** (not the pipe)

3. Calculate the Froude Number ( $Fr$ ) using the equation:

$$Fr = V_o / (32.2 \times Y_o)^{0.5}$$

4. Select a Dissipater Configuration from Figure F.7 that fits the geometry of the outlet.
- Choose an Expansion ratio ( $W_D/W_o$ ) and determine  $W_1/W_o$
  - Pick the Number of Rows ( $N_r$ ), and Number of Elements ( $N$ )
  - Pick  $h/y_A$  and  $L/h$
5. Determine the Approach Velocity  $V_A$ , using Figure F.8 for rectangular culverts or Figure F.9 for circular culverts.
6. Determine Average Depth of Flow ( $Y_A$ ) in expansion part of dissipater, using Figure F.10 for rectangular culverts or Figure F.11 for circular culverts.
7. Determine Dissipater Dimensions and Flow Parameters:
- Element Height ( $h$ )
  - Length between Rows ( $L$ )
  - Dissipater Width ( $W_D$ )
  - Element Width ( $W_1$ ) = Spacing between elements in rows
  - Divergence ( $u_e$ )

$$u_e = 4/7 + 10L/7W_o$$

- Dissipater Drag ( $C_D$ )
- Element Frontal Area ( $A_F$ ) =  $W_1 \times h$
- Momentum Correction Coefficient ( $C_P$ ) = **0.7**
- Length of Dissipater ( $L_D$ )

$$L_D = 2W_o + LN_r$$

8. Calculate  $C_D A_F N$  using the following equation:

$$C_D A_F N = \frac{2 (K_P - K_D)}{1.94 V_A^2}$$

$$\text{Where: } K_P = (1.94 V_O Q) + \frac{(43.7 Y_O^2) W_O}{2}$$

$$K_D = \frac{(1.94 V_D Q) + 62.4 Q^2}{2 V_D^2 (W_D)}$$

$$V_D = Q / (W_D \times TW)$$

9. Compute  $C_D A_F N$  from the values derived in steps 6 and 7 above.
10. If  $C_D A_F N$  computed in step 9 above is equal to or greater than that calculated in step 8, the design is satisfactory. If it is less, return to step 4 and select a new configuration from Figure F.7.
11. Determine the Riprap Protection requirement downstream of the Dissipater using Figure F.12.

EXAMPLE - An 8×8' Box Culvert, length = 235', slope = 0.02 ft/ft, Q design = 1400 cfs, n = 0.013, critical depth ( $y_c$ ) = 9.8', flow depth (d) = 6.0', Tailwater (TW) = 3.3', natural channel width = 41'

1. Discharge Flow Depth ( $Y_O$ ) = flow depth (d) = 6.0'
2. Discharge Velocity ( $V_O$ ) =  $Q/A = 1400 / (6 \times 8) = 29.1$  fps
3. Froude Number ( $Fr$ ) =  $V_O / (32.2 \times Y_O)^{0.5} = 29.1 / (32.2 \times 6.0)^{0.5} = 2.1$
4. Dissipater Configuration from Figure 9.17
  - a) Expansion Ratio ( $W_D/W_O$ ): Channel Width/Culvert Width =  $41/8 = 5.14$   
therefore  $W_1/W_O = 0.63$
  - b) Number of Rows ( $N_r$ ), 5 is chosen because 4 rows is found to be insufficient  
  
Number of Elements = 19
  - c)  $h/y_A = 0.71$  and  $L/h = 6$  are chosen
5. Approach Velocity ( $V_A$ ) - Roughness field begins at a distance  $2W_O$  from the Culvert. Since  $W_O = 8'$ , the field begins 16' from the culvert.

From Figure F.8,  $V_A/V_O = 1.05$

$$V_A = 1.05 \times V_O = 1.05 \times 29.1 = 30.6 \text{ fps.}$$

6. Average Depth of Flow ( $Y_A$ )

From Figure F.10,  $Y_A/Y_O = 0.33$

$$Y_A = 0.33 \times 6.0 = 1.98'$$

7. Dissipater Dimensions and Flow Dimensions

a) Element Height ( $h$ )

From Figure F.7,  $h/Y_A = 0.71$

$$h = 0.71 \times 1.98 \text{ feet} = 1.4 \text{ feet}$$

b) Length between Rows ( $L$ )

From Figure 8,  $L/h = 6$

$$L = 6 \times 1.4 \text{ feet} = 8.4 \text{ feet}$$

c) Dissipater Width ( $W_D$ )

From step (1),  $W_D/W_O = 5$

$$W_D = 5 \times 8 \text{ feet} = 40 \text{ feet}$$

d) Element Width ( $W_1$ )

From Figure F.7,  $W_1/W_O = 0.63$

$$W_1 = 0.63 \times 8.0 \text{ feet} = 5.04 \text{ feet, use 5 feet}$$

e) Divergence ( $u_e$ )

$$u_e = 4/7 + 10L/7W_O = 4/7 + 10(8.4)/(7 \times 8) = 2.07, \text{ use } 2$$

f) Dissipater Drag ( $C_D$ )

From Figure F.7,  $C_D = 0.38$

g) Element Frontal Area ( $A_F$ )

$$A_F = W_1 \times h = 5 \times 1.4 = 7 \text{ sq. ft.}$$

h) Momentum Correction Coefficient ( $C_P$ ) = 0.7

i) Length of Dissipater ( $L_D$ )

$$L_D = 2W_O + LN_r = (2 \times 8) + (8.4 \times 5) = 16 + 42 = 58 \text{ feet}$$

$$8. \quad C_{DAFN} = \frac{2(K_P - K_D)}{1.94 V_A^2}$$

$$K_P = (1.94V_O Q) + \frac{(43.7 Y_O^2) W_O}{2}$$

$$K_P = (1.94 \times 29.1 \times 1400) + \frac{(43.7 \times 6^2) \times 8}{2} = 79,035.6 + \frac{12579.84}{2}$$

$$K_P = 85,325.5$$

$$K_D = (1.94V_D Q) + \frac{62.4Q^2}{2V_D^2 (W_D)}$$

$$V_D = Q/(W_D \times TW) = 1400/(40 \times 3.3) = 10.6 \text{ fps}$$

$$K_D = (1.94 \times 10.6 \times 1400) + \frac{62.4 (1400)^2}{2 \times (10.6)^2 \times 40}$$

$$K_D = (28,789.6) + \frac{1.223 \times 10^8}{8988.8} = 42,395.9$$

$$C_{DAFN} = \frac{2(K_P - K_D)}{1.94 V_A^2} = \frac{2(85,325.5 - 42,395.5)}{1.94 (30.6)^2}$$

$$C_{DAFN} = 47.3$$

$$9. \quad C_{DAFN} = .38 \times 7 \times 19 = 50.5$$

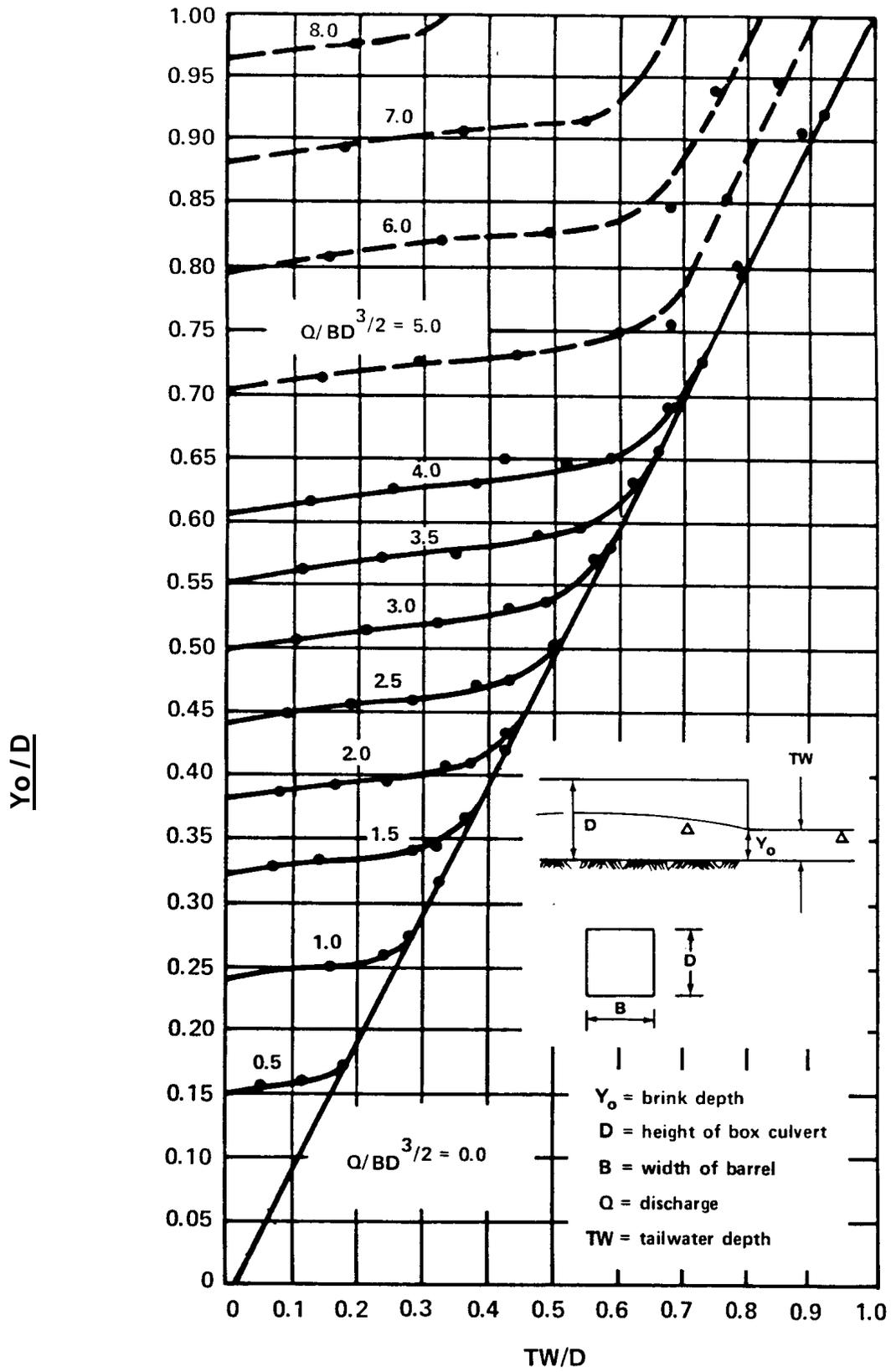
10.  $50.5 > 47.3$  Therefore, the dissipater configuration is O.K.

$$11. \quad V_D = 10.6 \text{ fps}$$

From Figure F.12, minimum  $d_{50}$  stone size = .7 feet. Round up to R-5.

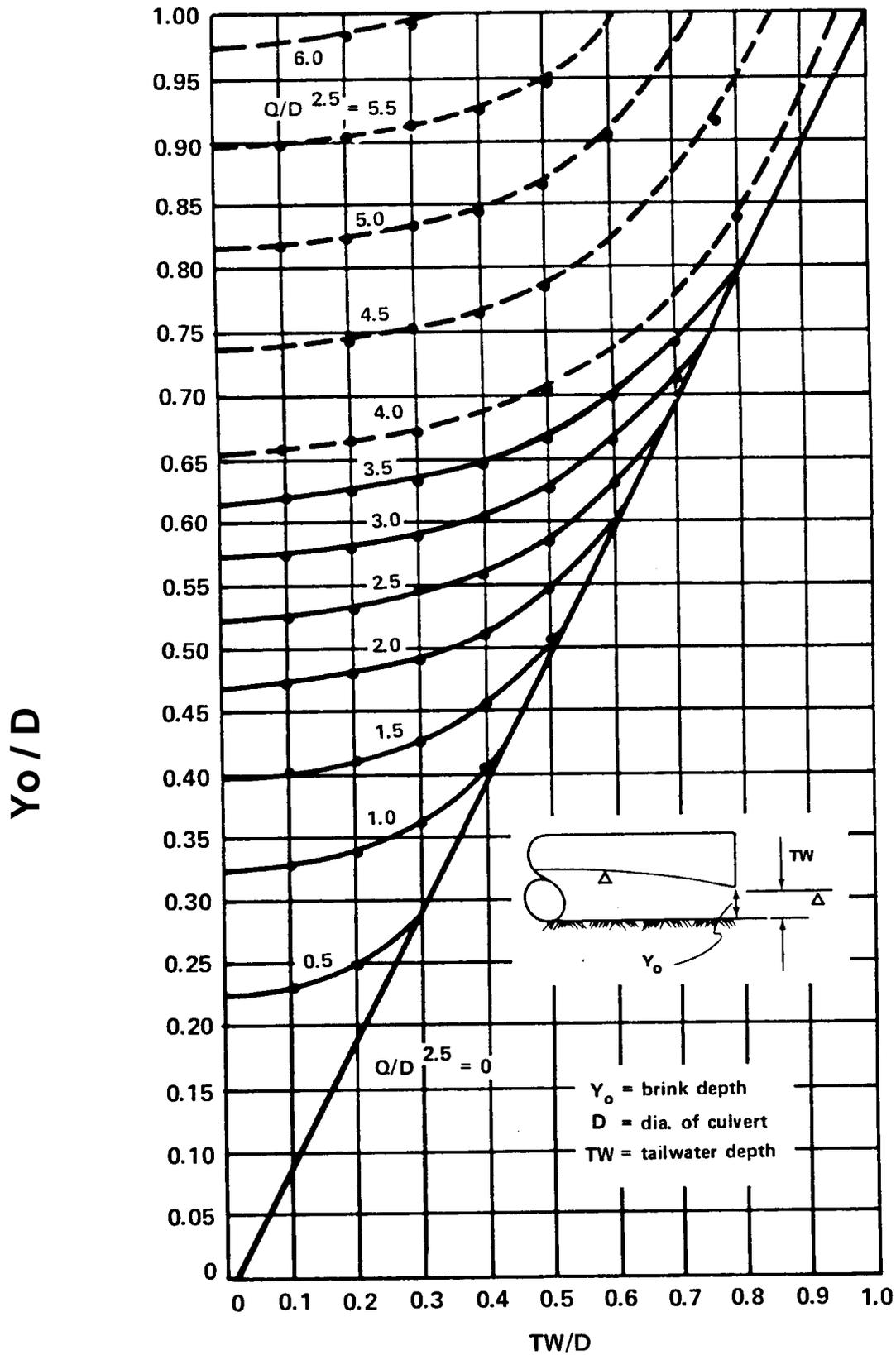
$10.6 < 11.5$  Therefore, R-5 is O.K.

**FIGURE F.4**  
**Dimensionless Rating Curves for Outlets of Rectangular Culverts on Horizontal**  
**and Mild Slopes**



USDOT, FHWA HEC 14

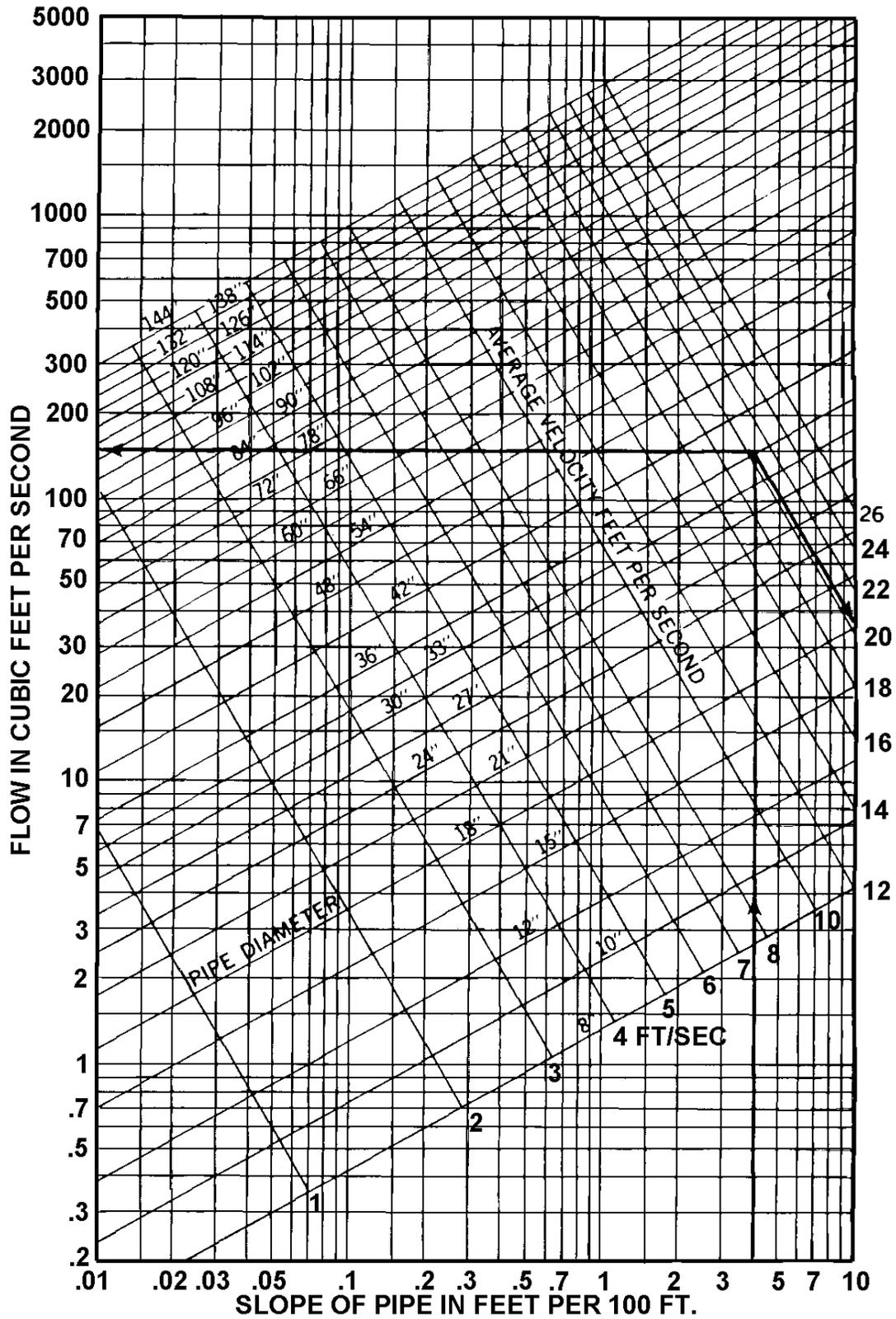
**FIGURE F.5**  
**Dimensionless Rating Curves for Outlets of Circular Culverts on Horizontal and Mild Slopes**



USDOT, FHWA HEC 14

**FIGURE F.6**  
**Flow for Circular Pipe Flowing Full**

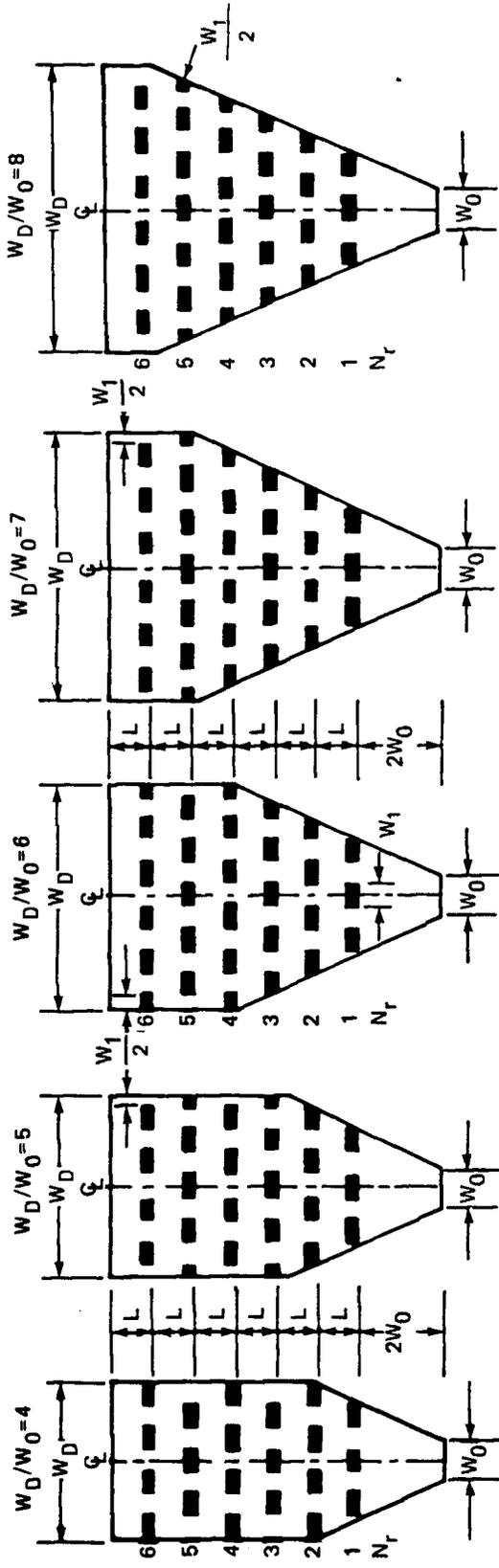
**BASED ON MANNING'S EQUATION  $n = 0.012$**



USDOT, FHWA HEC 14



**FIGURE F.7**  
**Design Values for Roughness Element Dissipaters**

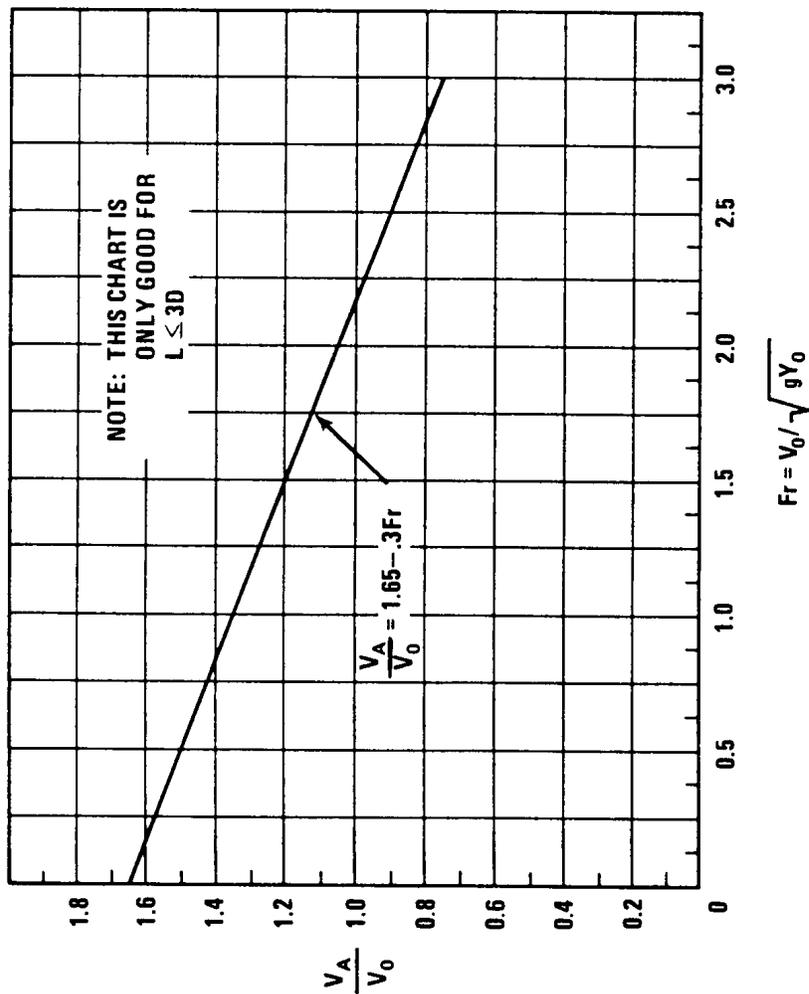
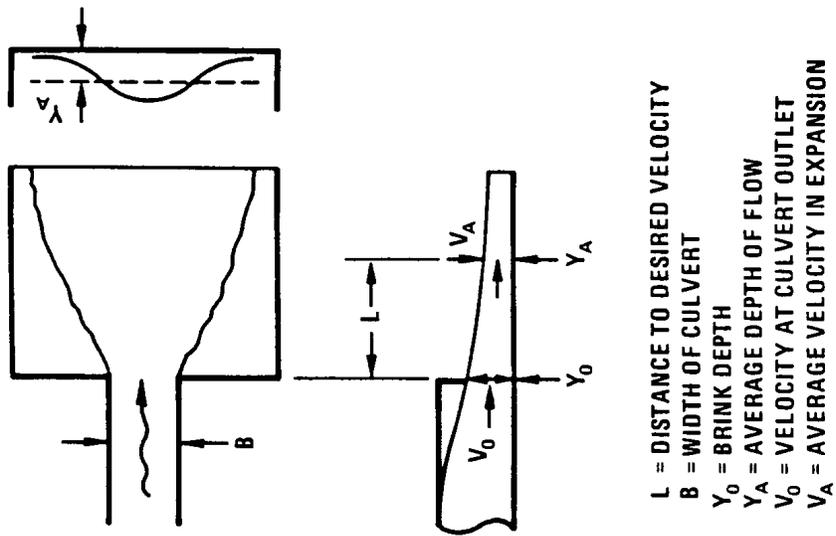


$W_D/W_0$	2 TO 4		5			6			7		8	
	.57		.63			.6			.58		.62	
$W_1/W_0$												
NO. ROWS ( $N_r$ )	4	5	6	4	5	6	4	5	6	5	6	6
NO. ELEMENTS (N)	14	17	21	15	19	23	17	22	27	24	30	30
$h/Y_A$	C <sub>B</sub> FOR ROUGHNESS ELEMENT DISSIPATORS											
L/h												
0.91	0.32	0.28	0.24	0.32	0.28	0.24	0.31	0.27	0.23	0.26	0.22	0.22
0.71	0.44	0.40	0.37	0.42	0.38	0.35	0.40	0.36	0.33	0.34	0.31	0.29
0.48	0.60	0.55	0.51	0.56	0.51	0.47	0.53	0.48	0.43	0.46	0.39	0.35
0.37	0.68	0.66	0.65	0.65	0.62	0.60	0.62	0.58	0.55	0.54	0.50	0.45
0.91	0.21	0.20	0.48	0.21	0.19	0.17	0.21	0.19	0.17	0.18	0.16	
0.71	0.29	0.27	0.40	0.27	0.25	0.23	0.25	0.23	0.22	0.22	0.20	
0.31	0.38	0.36	0.34	0.36	0.34	0.32	0.34	0.32	0.30	0.30	0.28	
0.48	0.45	0.42	0.25	0.40	0.38	0.36	0.36	0.34	0.32	0.30	0.28	
0.37	0.52	0.50	0.18	0.48	0.46	0.44	0.44	0.42	0.40	0.38	0.36	

**DESIGN VALUES FOR ROUGHNESS ELEMENT DISSIPATORS**

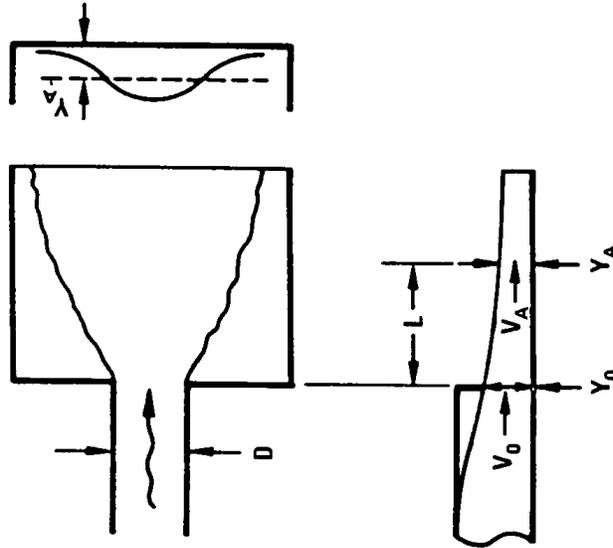
RECTANGULAR  
 CIRCULAR

**FIGURE F.8**  
**Average Velocity in Abrupt Expansion below Rectangular Outlet**

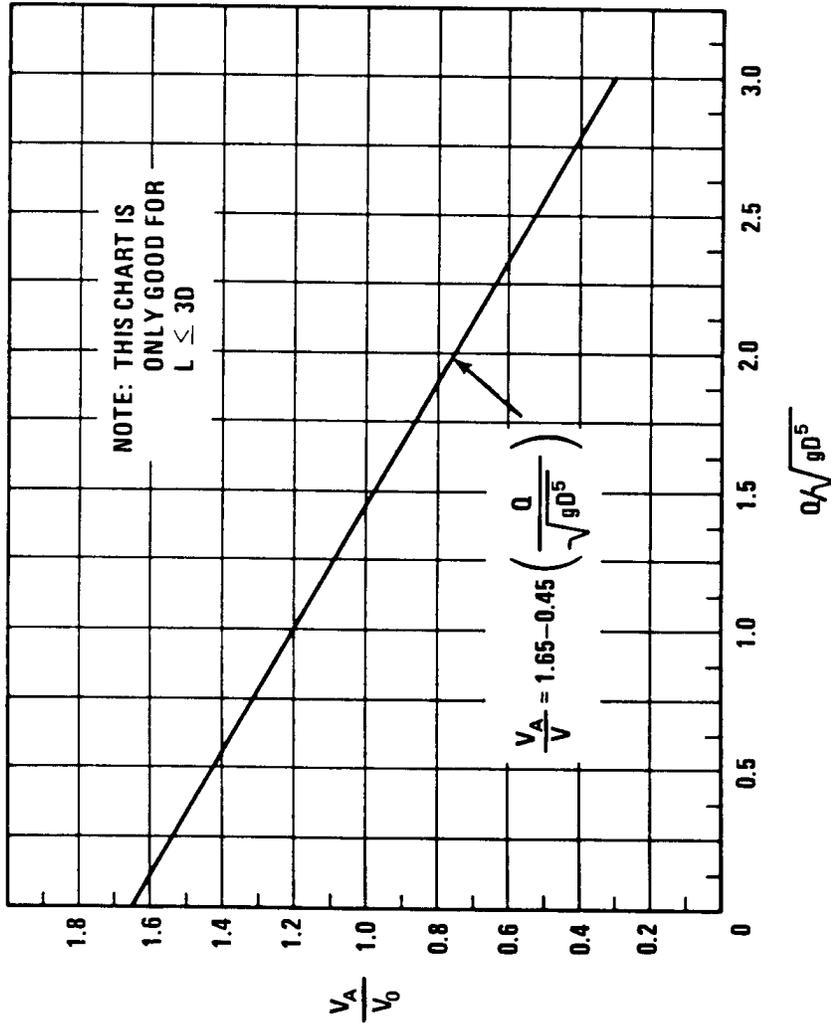


USDOT, FHWA HEC 14

**FIGURE F.9**  
**Average Velocity for Abrupt Expansion below Circular Outlet**

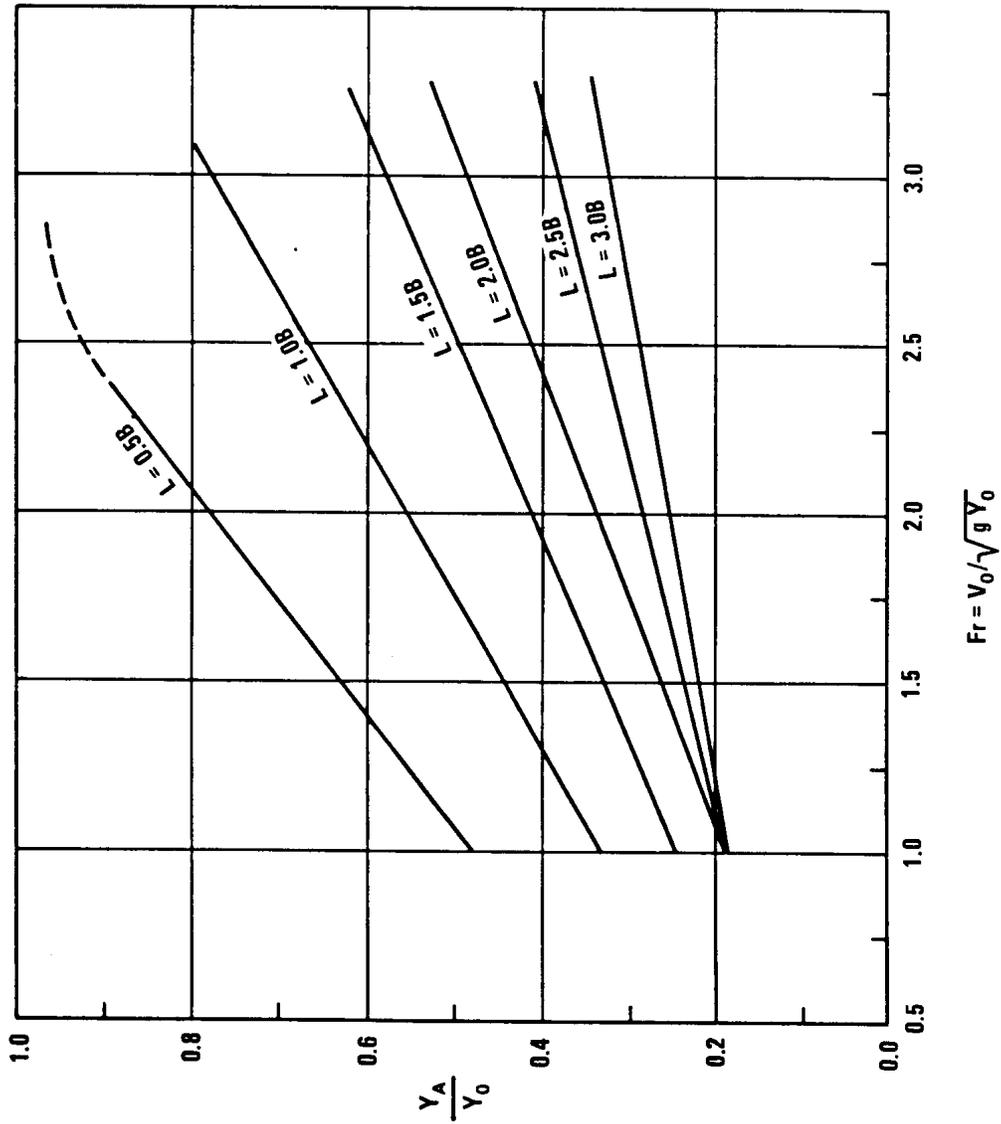
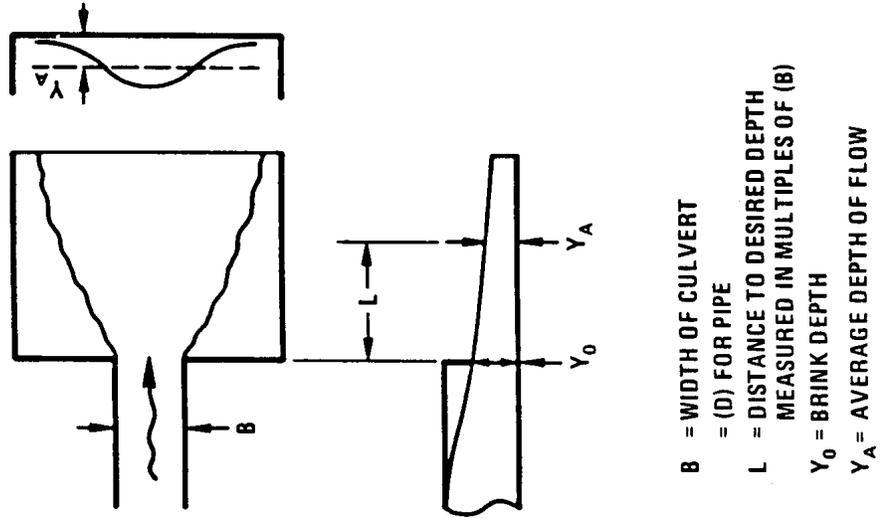


- L = DISTANCE TO DESIRED VELOCITY
- D = DIAMETER OF CULVERT (FT)
- $Y_0$  = BRINK DEPTH
- $Y_A$  = AVERAGE DEPTH OF FLOW
- $V_0$  = VELOCITY AT CULVERT OUTLET
- $V_A$  = AVERAGE VELOCITY IN EXPANSION



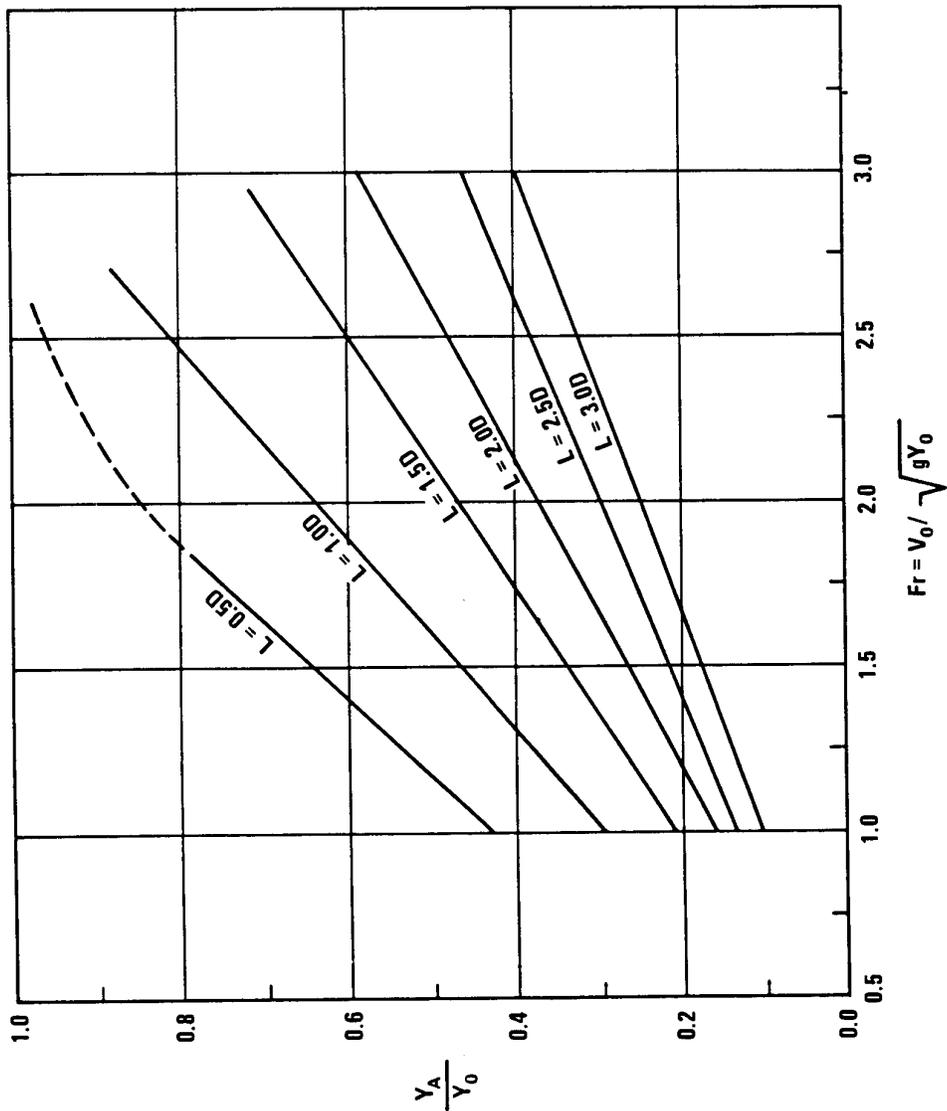
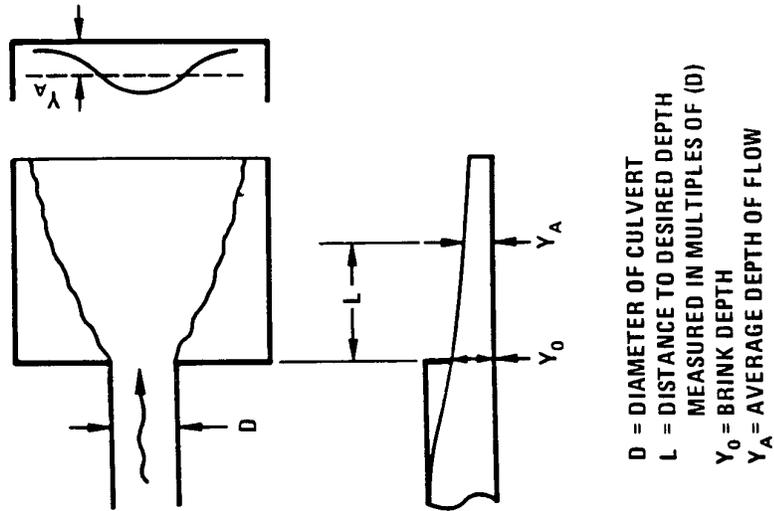
USDOT, FHWA HEC 14

**FIGURE F.10**  
**Average Depth for Abrupt Expansion below Rectangular Outlet**



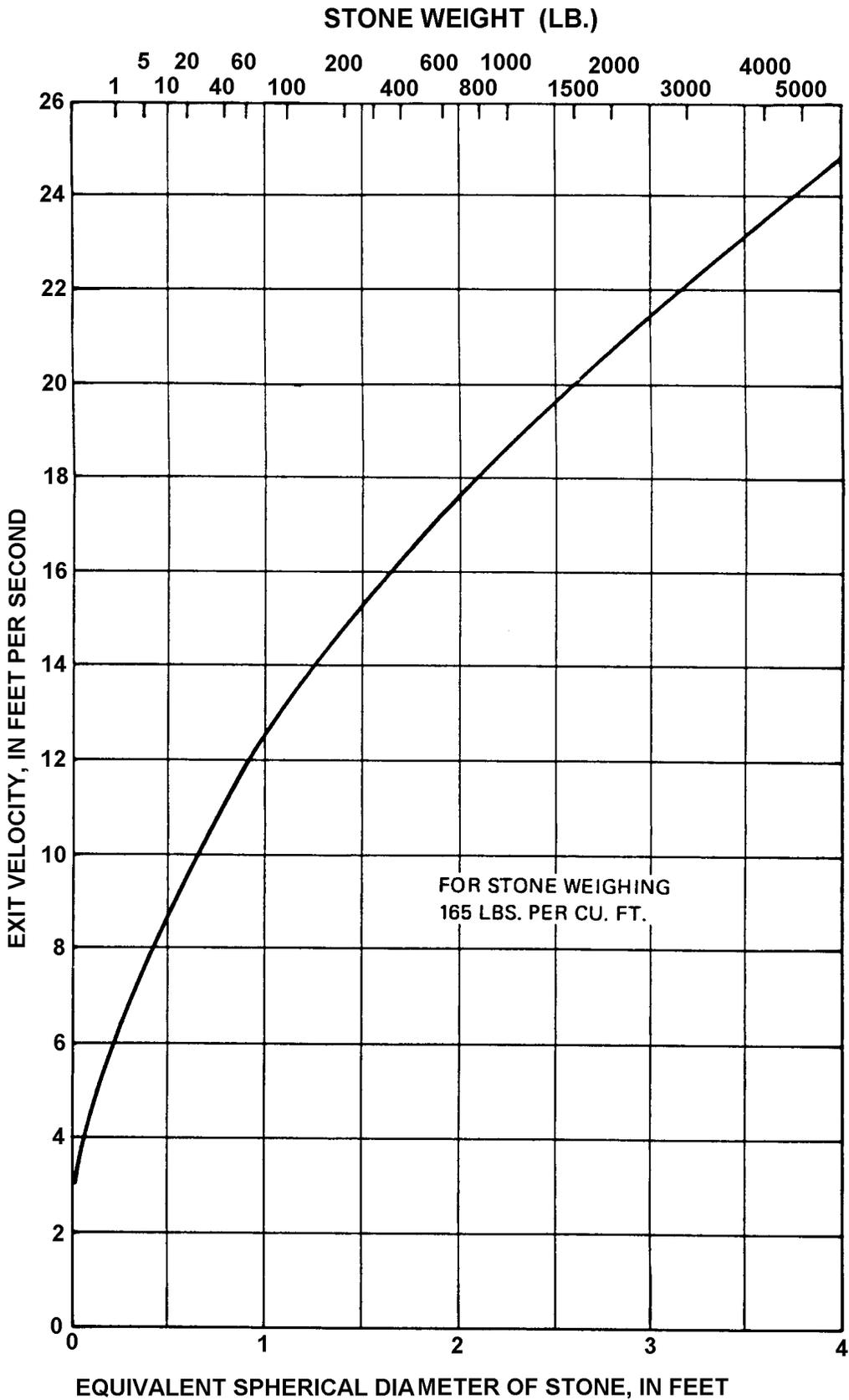
USDOT, FHWA HEC 14

**FIGURE F.11**  
**Average Depth for Abrupt Expansion below Circular Outlet**



USDOT, FHWA HEC 14

**FIGURE F.12**  
**Riprap Size for Use Downstream of Energy Dissipaters**



USDOT, FHWA HEC 14

IMPACT DISSIPATERS are box-like structures used at culvert or channel outlets to dissipate energy without reliance upon tailwater.

### DESIGN RESTRICTIONS

1. Maximum Discharge Rate (Q) = 400 cfs Note: Two or more Impact Dissipaters may be constructed side by side where needed.
2. Maximum Discharge Velocity (V<sub>o</sub>) = 50 fps.
3. Maximum Tailwater =  $h_3 + (h_2/2)$
4. Maximum Culvert Slope = 0.27 ft/ft For culverts with slopes greater than 0.27 ft/ft, a horizontal section of at least 4 conduit widths long should be provided immediately upstream of the dissipater.
5. In Soils that are not Erosion-Resistant (i.e. having a k factor > 0.37), the Alternative End Sill and 45° Wingwall Design should be used.
6. A Cutoff Wall should be provided at the end of the dissipater to prevent undermining.
7. Riprap should be provided downstream of the dissipater for a distance equal to at least 4 culvert widths. The size of the riprap should be determined from Figure F.12.
8. Flows should be free of debris or substantial ice build-up.

### DESIGN PROCEDURE

1. Compute Flow Area (A) from the Design Discharge (Q) and the Anticipated Velocity (V<sub>o</sub>) using the equation:

$$A = Q / V_o$$

2. Calculate Y<sub>e</sub> for a rectangular section of equivalent area twice as wide as depth of flow:

$$Y_e = (A / 2)^{0.5}$$

3. Compute the Froude Number (F<sub>r</sub>):

$$F_r = V_o / (g Y_e)^{0.5}$$

4. Calculate the Energy Head (H<sub>o</sub>) at the end of the conduit:

$$H_o = Y_e + V_o^2 / 2g$$

5. Using Figure F.13, Determine Basin Width (W).

6. From Table F.1, determine the remaining dissipater dimensions indicated in Figure F.14.

EXAMPLE - Given: Circular Concrete Culvert Pipe, D = 48", Slope = 0.15 ft/ft, Q =300 cfs,  
n = 0.015, V<sub>o</sub> = 40 fps, Y<sub>o</sub> = 2.3 feet

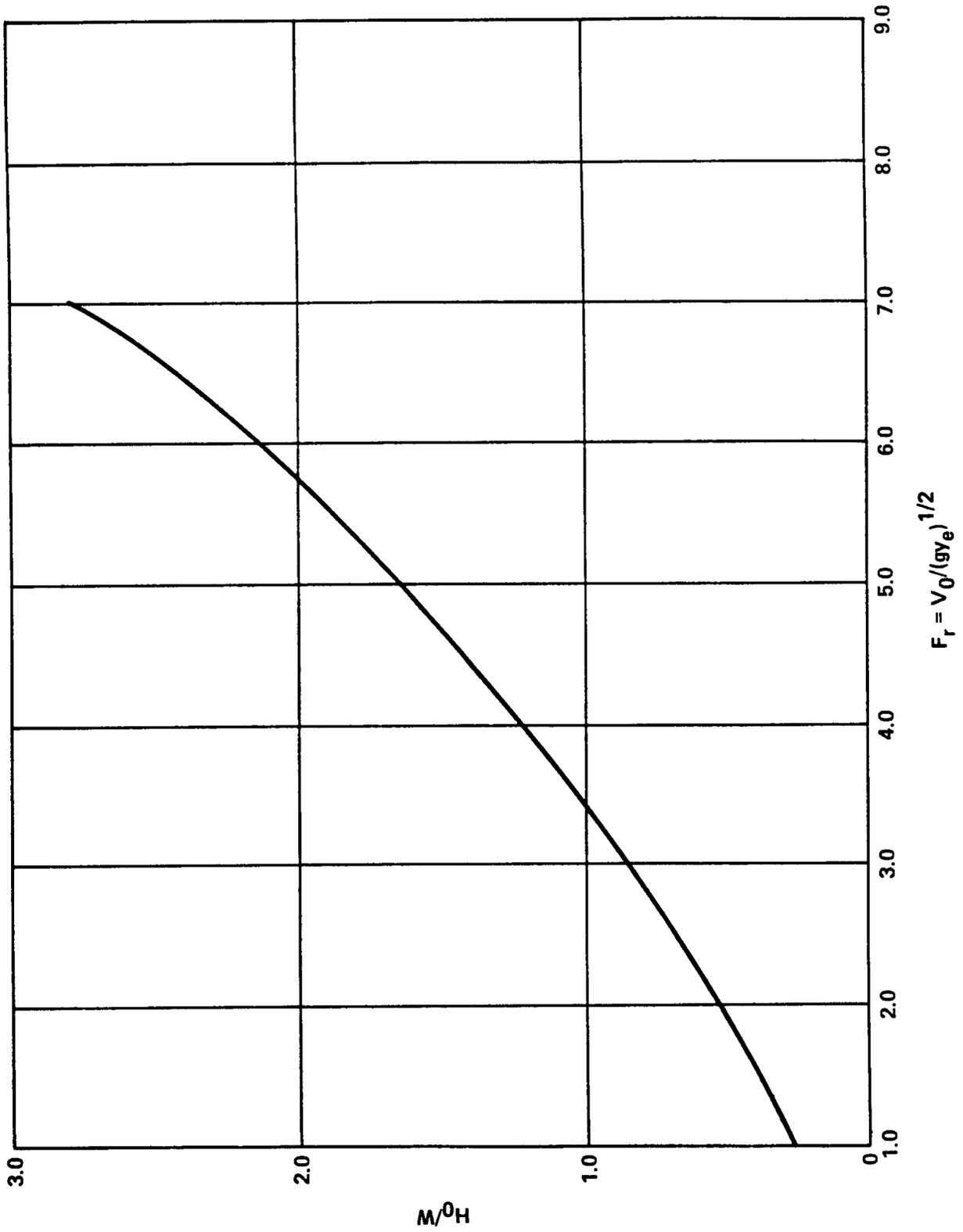
1. Flow Area (A):  $A = Q / V_o = 300 / 40 = 7.5$  sq. ft.
2.  $Y_e = (A / 2)^{0.5} = (7.5 / 2)^{0.5} = 1.94$  feet
3. Froude Number (F<sub>r</sub>):  $F_r = V_o / (g Y_e)^{0.5}$   
 $F_r = 40 / (32.2 \times 1.94)^{0.5} = 5.05$
4. Energy Head (H<sub>o</sub>):  $H_o = Y_e + V_o^2 / 2g = 1.94 + (40)^2 / 64.4$   
H<sub>o</sub> = 26.8 feet
5. Using Figure F.13, determine basin width (W).  
H<sub>o</sub> / W = 1.68  
W = 26.8 / 1.68 = 16.0 feet
6. The remaining dissipater dimensions are those from the line in Table F.1 corresponding to W = 16'.

**TABLE F.1**  
**Impact Dissipater Dimensions (ft - inches)**

W	h <sub>1</sub>	L	h <sub>2</sub>	h <sub>3</sub>	L <sub>1</sub>	L <sub>2</sub>	h <sub>4</sub>	W <sub>1</sub>	W <sub>2</sub>	t <sub>3</sub>	t <sub>2</sub>	t <sub>1</sub>	t <sub>4</sub>	t <sub>5</sub>
4-0	3-1	5-5	1-6	0-8	2-4	3-1	1-8	0-4	1-1	0-6	0-6	0-6	0-6	0-3
5-0	3-10	6-8	1-11	0-10	2-11	3-10	2-1	0-5	1-5	0-6	0-6	0-6	0-6	0-3
6-0	4-7	8-0	2-3	1-0	3-5	4-7	2-6	0-6	1-8	0-6	0-6	0-6	0-6	0-3
7-0	5-5	9-5	2-7	1-2	4-0	5-5	2-11	0-6	1-11	0-6	0-6	0-6	0-6	0-3
8-0	6-2	10-8	3-0	1-4	4-7	6-2	3-4	0-7	2-2	0-7	0-7	0-6	0-6	0-3
9-0	6-11	12-0	3-5	1-6	5-2	6-11	3-9	0-8	2-6	0-8	0-7	0-7	0-7	0-3
10-0	7-8	13-5	3-9	1-8	5-9	7-8	4-2	0-9	2-9	0-9	0-8	0-8	0-8	0-3
11-0	8-5	14-7	4-2	1-10	6-4	8-5	4-7	0-10	3-0	0-9	0-8	0-8	0-8	0-4
12-0	9-2	16-0	4-6	2-0	6-10	9-2	5-0	0-11	3-0	0-10	0-10	0-8	0-9	0-4
13-0	10-0	17-4	4-11	2-2	7-5	10-0	5-5	1-0	3-0	0-10	0-11	0-8	0-10	0-4
14-0	10-9	18-8	5-3	2-4	8-0	10-9	5-10	1-1	3-0	0-11	1-0	0-8	0-11	0-5
15-0	11-6	20-0	5-7	2-6	8-6	11-6	6-3	1-2	3-0	1-0	1-0	0-8	1-0	0-5
16-0	12-3	21-4	6-0	2-8	9-1	12-3	6-8	1-3	3-0	1-0	1-0	0-9	1-0	0-6
17-0	13-0	22-6	6-4	2-10	9-8	13-0	7-1	1-4	3-0	1-0	1-1	0-9	1-0	0-6
18-0	13-9	23-11	6-8	3-0	10-3	13-9	7-6	1-4	3-0	1-1	1-1	0-9	1-1	0-7
19-0	14-7	25-4	7-1	3-2	10-10	14-7	7-11	1-5	3-0	1-1	1-2	0-10	1-1	0-7
20-0	15-4	26-7	7-6	3-4	11-5	15-4	8-4	1-6	3-0	1-2	1-2	0-10	1-2	0-8

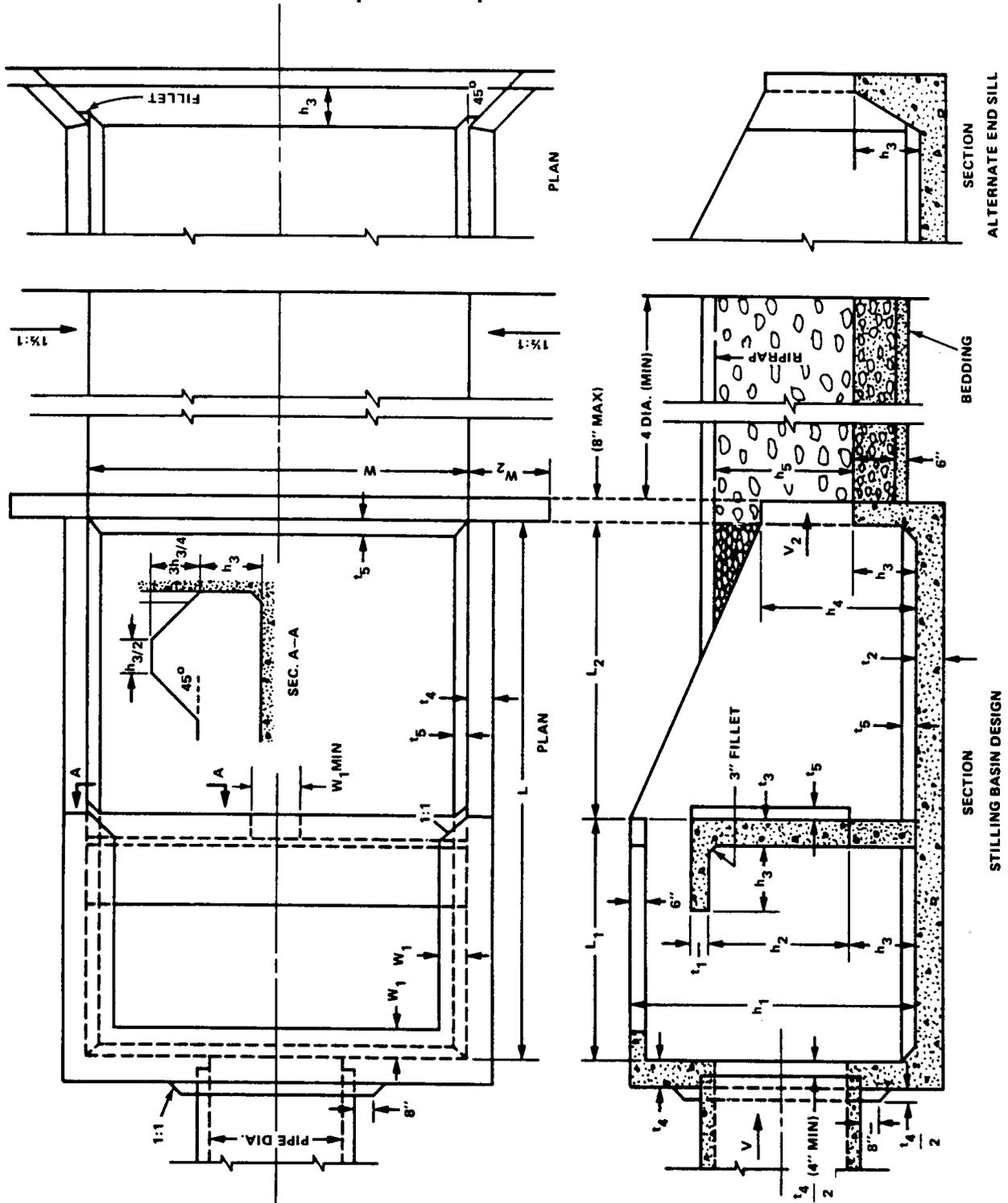


FIGURE F.13  
Design Curve for Impact Dissipaters



USDOT, FHWA HEC 14

FIGURE F.14  
Impact Dissipater Dimensions



USDOT, FHWA HEC 14

## APPENDIX G - Technical Paper: “Level Spreaders and Off-site Discharges of Stormwater to Non-surface Waters”

09-15-2007 Level Spreaders and Off-Site Discharges of Stormwater to Non-Surface Waters 1 *Level Spreaders and Off-Site Discharges of Stormwater to Non-Surface Waters*

By Domenic Rocco, P.E., CPESC Waterways Engineering and Wetlands Program

### I. FORWARD

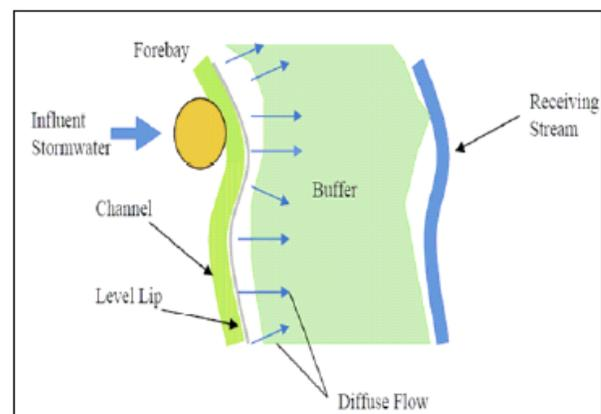
This paper compliments the guidance provided in the *Pennsylvania Stormwater Management Best Management Practices Manual (BMP Manual)*, Technical Guidance Document 363-0300-002 12/30/2006, specifically *BMP 6.8.1: Level Spreaders*. This paper also references the *Pennsylvania Erosion and Sediment Pollution Control Program Manual (E&S Manual)*, Technical Guidance Document 386-2134-001 4/15/2000. Both of these documents are available online [www.depweb.state.pa.us](http://www.depweb.state.pa.us): click the following: Forms and Publications (eLibrary), Technical Guidance Final Documents, Clean Water.

### II. BACKGROUND

Favorable conditions in the real estate market and the demand for housing have created a significant boom in land development, particularly in urban and suburban areas. Due to high property values, many sites that were previously passed over as “not developable” are now sought for development. As a result, federal, state and local regulatory agencies have experienced an increase in high complexity projects, some of which only involve a few acres. In addition, the NPDES Phase 2 Revisions (March 2003), which reduced the permitting threshold from 5 acres to 1 acre, has also significantly increased the number of projects encountered by these agencies. As a result, there is an increased demand for guidance and direction for both the project proponent and the regulator.

This paper focuses on the situation where stormwater discharges are proposed to be directed to off-site areas that are not surface waters (i.e. uplands) or to areas unsuitable for carrying storm event flows. This can include overland flows that discharge to an open area, or follow an existing swale or other natural flow path lacking clearly defined bed and banks. Often these sites involve discharges that traverse over one hundred feet before reaching a surface water body. The flow path of these stormwater discharges often cross adjoining properties owned by other parties, which adds another layer of complexity to the issue. Even though these proposed stormwater discharges might follow an existing swale or other natural flow path, they normally exceed the volume and duration of the stormwater that currently follows the same flow path (prior to land development activities). This increased *flow exposure* may cause adverse impacts on the conveyance system or the receiving stream. These proposed stormwater discharges typically result in accelerated erosion and damages, often times on adjoining properties. A typical outfall structure with a riprap energy dissipater is not sufficient to deal with this issue. Faced with this situation, the BMP of choice by developers and their consultants has typically been the level spreader - in some shape or form.

Lack of guidance on level spreaders for this purpose has led to many stormwater plans that have failed to address this type of situation correctly. The “typical” level spreader (as shown to the right) and associated guidance found in most available reference materials is intended for stormwater discharges adjacent to riparian buffers or wetlands releasing the “water quality” storm or other smaller storm event. The situation described in the previous paragraph is different and calls for an “atypical” level spreader designed to discharge all anticipated flow without an opportunity for a stable bypass for high flows. This paper describes situations where a level spreader may or may not be appropriate and provides guidance on



Source: Evaluation of Level Spreaders in the Piedmont of North Carolina

proper planning, design, and construction and, as a result, should help alleviate the potential for off-site erosion, flooding, or property damage caused by uncontrolled stormwater discharges.

Due to numerous issues related to this subject matter, a technical work group involving PA DEP, PennDOT and the conservation districts of Bucks, Chester, Delaware, Montgomery and Lehigh Counties was convened to deal with the issue of uncontrolled stormwater discharges. The findings of the technical work group were incorporated in this paper.

Source: *Evaluation of Level Spreaders in the Piedmont of North Carolina* 09-15-2007 Level Spreaders and Off-Site Discharges of Stormwater to Non-Surface Waters 2

### **III. INTRODUCTION TO LEVEL SPREADERS**

Level spreaders are structures that are designed to uniformly distribute concentrated flow over a large area essentially converting concentrated flow to sheet flow. Level spreaders come in many types and functions, depending on the peak rate of inflow, the site conditions, the duration of use, and the type of pollutant (if any). Infiltration and water quality functions are both possibilities, which are dependent on site constraints. Examples of common level spreaders include: concrete sills (or lips), curbs, earthen berms, and level perforated pipes discharging to the surface or sub-surface. (See **Figures G.3 and G.5** for sample illustrations)



Source: Chester County Conservation District

Typically, level spreaders function as follows:

1. Concentrated flow enters the level spreader through a pipe, ditch, or swale.
2. The concentrated flow is impeded and its energy is dissipated.
3. The flow is distributed over the length of the level spreader.
4. The velocity of the flow is reduced to a level that can be tolerated down slope.
5. Water is discharged simultaneously across the same elevation, theoretically, in a uniform manner along the entire length.

### **IV. PRACTICAL CONSIDERATIONS**

Prior to specifying a level spreader, the designer should consider the following items, to the maximum extent practicable:

1. Avoid and minimize potential conflicts with discharges to non-surface waters, all together.
2. Fully consider alternatives that would have less impact on the environment, including constructing conveyances for anticipated flows (either open channel or closed channel) to a surface water feature or to a storm sewer capable of carrying those flows. The developer would be responsible for working with adjacent property owners for consent.
3. Endeavor to maximize volume reduction and other stormwater BMPs— both non-structural and structural - throughout the site. (not just in the vicinity of a detention basin)

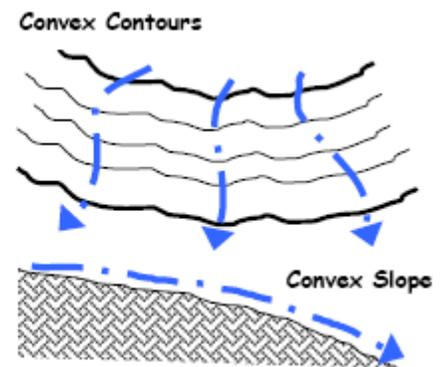
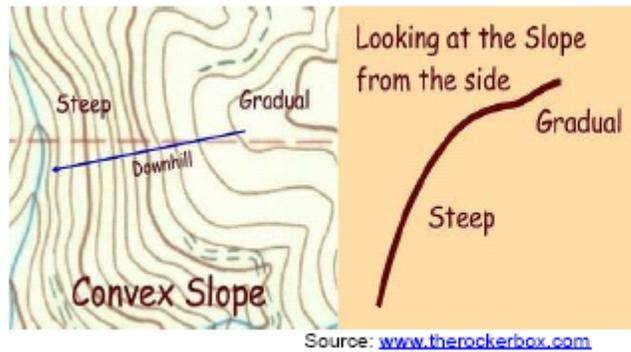
4. Limit the formation of concentrated flow, since it is simpler to maintain sheet flow discharge rather than to redistribute it after it is concentrated.

## **V. ENGINEERING CONSIDERATIONS**

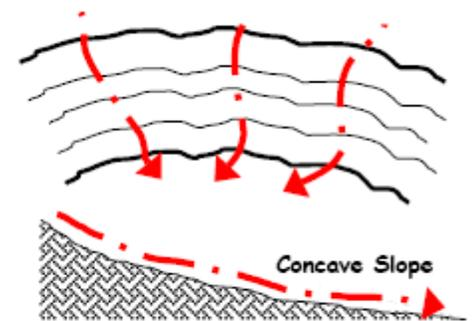
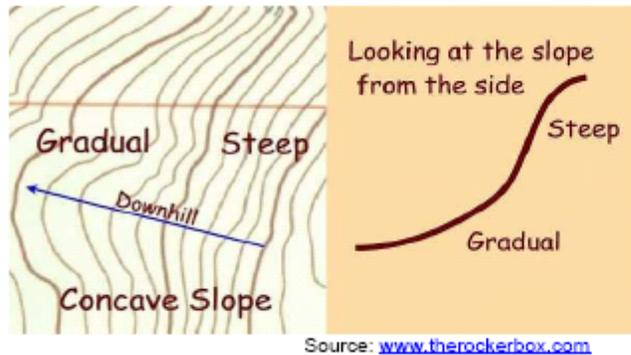
1. Level Spreaders should be constructed and maintained level (i.e. constructed along an existing contour). Small variations in height on the downstream lip will quickly result in gullies. Experience suggests that variations of more than **0.05%** slope along the weir (approx. 0.25 inches per 42 feet of weir) will in time cause water to quickly reconcentrate and potentially erode areas down slope of the level spreader. (Hunt et al, 2001) It is imperative that the site selected for level spreader installment be nearly level before construction. Variations in existing ground elevation of more than **4 inches** across the entire length of the level spreader can make “level” construction difficult. (See **Item 7**)
2. Specific site conditions, such as topography, vegetative cover, soil, and geologic conditions should be considered prior to design. Field verification is essential to achieve project success. Level spreaders are not applicable in areas comprised of easily erodible soils (including fill) and/or sparse vegetation. Undisturbed earth with a grass cover is much more resistant to erosion than fill– despite thorough compaction. Even with what appears to be a good young stand of grass over fill, erosion is likely to occur. Level spreaders should be located away from newly deposited earth.
3. Designers should consider the following items for level spreaders with respect to optimizing performance, maximizing effectiveness, and reducing the potential for reconcentrated flow:
  - Land Surface Shape: When siting a level spreader, the designer should avoid locating the level spreader on concave slopes or concave contours. See **Figure G.1**.
  - Soil slope: Gentle/gradual uniform slopes are ideal, with a maximum slope of **6%** from level spreader to toe of slope (i.e. top of stream bank). The first **10 feet** of buffer/vegetated filter strip down slope of the level spreader should not exceed **4%** slope. For greater slopes or if construction of a level spreader cannot be accomplished without clearing/removing down slope vegetation, the designer should not use a level spreader and instead install a typical conduit and outfall extending to an adequate surface water body or storm sewer. (See **Section VIII** on *Outfall Design*) If significant issues with bedrock are encountered, then permanent slope pipes may be considered, if allowable at the local level.
  - Slope Length: The maximum distance to a receiving stream or storm sewer should be about **100 feet**. Greater distances may be considered on a case-by-case basis for very mild slopes ( $\leq 1\%$ ) and heavily vegetated (grassy) areas but ideally should not exceed **150 feet**. When greater distances cannot be avoided, the designer should incorporate other mitigative measures such as:
    - a. Incorporating an infiltration BMP with the goal of providing no discharge of storm events up to the **10-year storm**. (e.g. See *Pennsylvania Stormwater Best Practices Manual, 6.4.4 Infiltration Trench*)
    - b. Limiting the drainage area to **1 acre** or less with minimal runoff from impervious areas.

**Figure G.1. Convex Contours and Slopes are Less Susceptible to Reconcentrating Flows.**

Optimal



Less Favorable



#### Hydraulics and Hydrology for Level Spreaders:

- a. Level spreaders, in this context, should safely diffuse flows up to the **100-year storm**. A minimum design criterion per the BMP Manual is the **10-year storm** - conditions permitting. This is due to the inability to bypass and to accommodate the magnitude of anticipated discharges.
- b. The drainage area to a given level spreader should be limited to **5 acres** or less, which should encourage smaller and more manageable BMPs, both during and after construction. For conveyances with drainage areas exceeding 5 acres, multiple outfalls/level spreaders are preferable to a single outfall/level spreader. A maximum flow rate or volume may be imposed in critical areas, such as special protection watersheds, impaired watersheds, etc. The recommendations in this paper could be relaxed for very small drainage areas (< **500 square feet**), such as disconnected rooftops, etc.
- c. Level spreader length is the lineal measurement of weir required to discharge anticipated flows. It is measured perpendicular to the direction of flow. Level spreader length is primarily dependent on the influent rate and the type of down slope cover. The level spreader length needs to be designed so that the allowable down slope velocity is not exceeded. Other factors include the discharge pipe diameter (if applicable) and the number and size of perforations along the discharge pipe (if applicable). Generally, level spreaders should have a minimum length of **10 feet** and a maximum length of **200 feet**.
  - 1) Refer to **Section VII** for a more comprehensive description of the considerations involved in designing level spreaders and determining proper length.

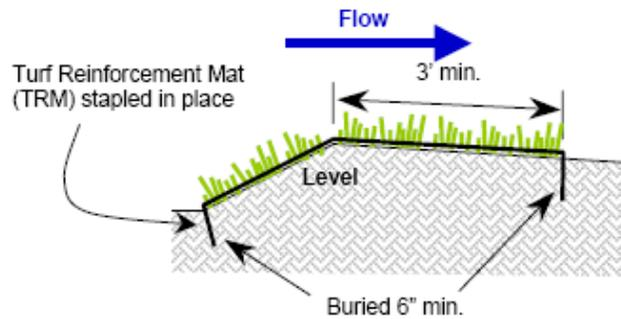
- 2) The *Pennsylvania Stormwater Best Practices Manual* recommends level spreader lengths for two ground cover conditions:
- Dense grass ground cover (13 linear feet for every 1 cfs of flow).
  - Forested areas w/ no ground cover. (100 linear feet for every 1 cfs of flow)

These conditions represent two extremes and it can be argued that most projects would fall somewhere in between. It is essential that a site analysis of the down slope condition (up to the receiving stream) be performed to properly determinate the maximum allowable velocity. Designers should be very cautious in using “rules of thumb” without understanding the underlying principles and assumptions.

- For instance, the *13 linear feet per cfs of discharge* is based on optimal ground cover conditions (dense grass) and no existing erosion formations.
- Ground cover for the other extreme condition, forested areas (*100 linear feet per cfs of discharge*), is based on little to no vegetal ground cover. As discussed in **Section VII**, this recommendation may be overly conservative for the situation where a good mulch ground layer exists. (e.g. mature forest)
- Therefore, in natural conditions, the range for level spreader length per cfs of discharge should fall between **13** and **100 linear feet**. This range is almost one order of magnitude; hence it further emphasizes the need for the designer to understand the down slope area and its limitations.

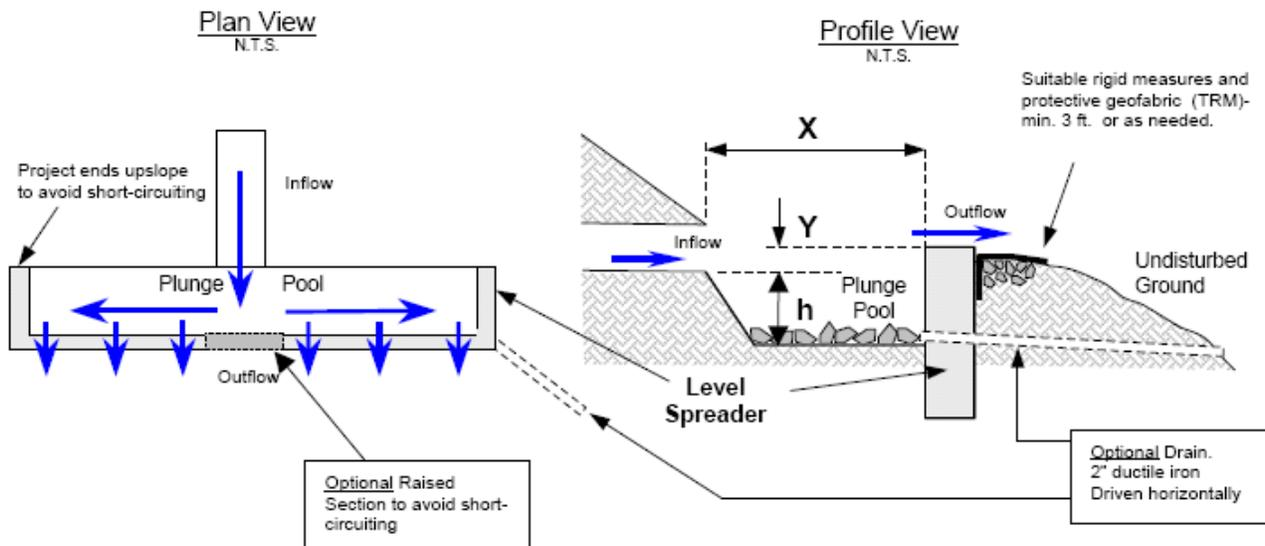
- 3) For designs involving a subsurface discharge utilizing a perforated pipe, determination of the perforation discharge per linear foot of pipe may dictate the total required length of level spreader. Follow the design criteria described in BMP 6.8.1: Level Spreaders in the BMP Manual. This may require information from the pipe manufacturer including perforation dimensions and average head above the perforation.
- Prior to discharge entering a level spreader, the flow should pass through a drop manhole/inlet to dissipate most of the energy. The pipe entering the level spreader should be at a maximum **1% slope**. For channel flow, the grade of the last **20 feet** of the channel before the level spreader should create a smooth transition from the channel grade to the level spreader and, where possible, should be less than or equal to **1%**.
  - Level spreaders with design flows ( $Q_{100}$ ) in excess of **4 cfs** should have a rigid lip consisting of non-erodible material, typically concrete curbing with the invert founded below the frost line and anchored into the soil with an appropriately-sized concrete footer. (NRCS IL-570, 1999)
  - A vegetated lip may be suitable for low flows depending on soil characteristics. In these instances, the lip should be protected with a turf reinforcement mat (TRM), for a minimum of **3 feet** down slope to prevent erosion and to enable establishment of vegetation. (See **Figure G.2**). More design considerations involving earthen berms are described in *Pennsylvania Stormwater Best Practices Manual 6.4.10: Infiltration Berms*.

**Figure G.2. Turf Reinforcement Mat (TRM) for Level Spreader with Vegetated Lip**



- g. It is noted that level spreaders constructed out of earthen berms, pre-cast concrete curb sections, etc. are likely to require continual maintenance in order to keep them level. Experience has shown that a cast-in-place concrete berm with the invert below the frost line requires less maintenance and is most likely to sustain long-term use than earthen berms and pre-cast concrete curb sections. Timber should be avoided due to issues with deformation and decomposition.
  - h. There should be a smooth transition between the level spreader and native ground. Ideally, the lip of the concrete level spreader should be no higher than **3 to 4 inches** off the existing ground. (Hathaway and Hunt, 2006) This would allow water to pass over the lip with minimal interference from vegetation. (See **Item 7c** and **Figure G.4**)
5. Level spreader orientation, where practicable, should be designed to allow for an even flow distribution. This is typically accomplished by utilizing a T-shape. (See **Figures G.3** and **G.5**)

**Figure G.3. Typical Orientation of Level Spreader with Surface Discharge**



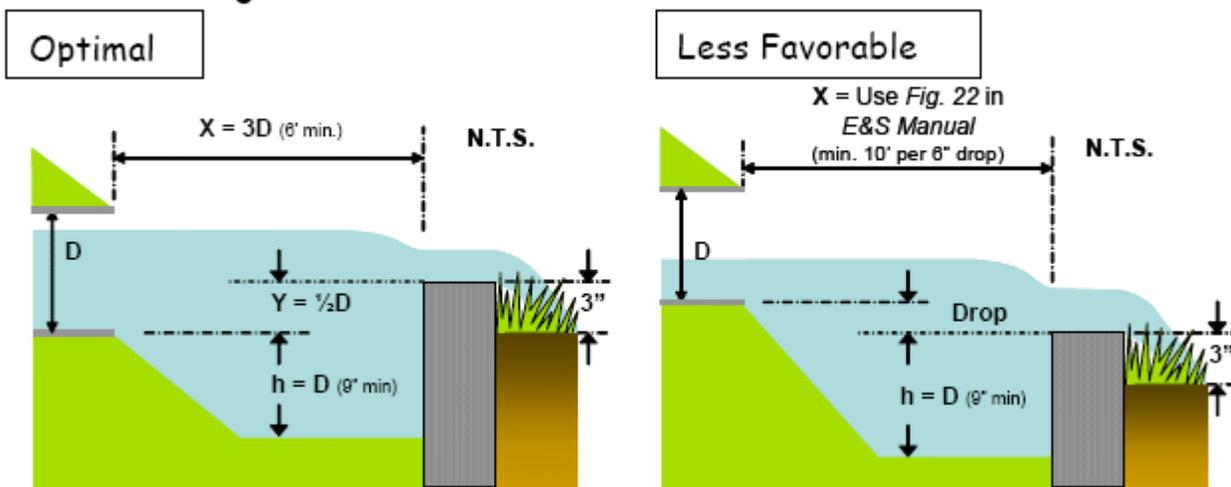
6. Functional considerations for level spreaders:
- a. Avoid short-circuiting and overloading in the plunge pool (surface discharge):
    - i. To avoid short-circuiting, the ends of the level spreader weir should be projected upslope, slanted upgradient and keyed into the slope.
    - ii. The level spreader should include a plunge pool with sufficient depth (**h**) to minimize short-circuiting potential. At a minimum, **h** should be the greater of **9 inches** or the



inside diameter (**D**) of the inflow pipe (Hathaway and Hunt, 2006). For channel flow, the designer can use the equivalent pipe diameter. Riprap placed in the bottom of the plunge pool should be sized according to anticipated inflow velocities. Use the recommended riprap gradation in Table 6.6. (Minimum **R-3**)

- iii. The vertical separation (**Y**) between the inflow (pipe or channel) and outflow (weir) inverts should provide sufficient freeboard to allow for energy dissipation. At a minimum, **Y** should be equal to half of the inside pipe diameter (**D**). Where freeboard is not possible, there should be a minimum **6-inch** drop per **10 linear feet** of plunge pool length (See Profile View of **Figure G.3**).
- iv. The level spreader should provide sufficient length (**X**) between the inflow point and the outflow weir to avoid overtopping. If the distance (**X**) does not meet this criterion, the potential for short-circuiting will increase significantly below the inflow point. In this situation, the level spreader can include a raised middle section down slope of the inflow point to prevent overtopping and to direct flow laterally. The crest of the raised section should be equal to the crown elevation of the inflow pipe. (See Plan View of **Figure G.3**)
- v. Recommended values for **X**: (See **Figure G.4**)
  - If  $Y \geq \frac{1}{2}D$ , then  $X = 3D$  (Minimum 8')
  - If  $Y < \frac{1}{2}D$ , then use Figure 9.4 to find **X**. (Minimum 10')

**Figure G.4. Variation of Plunge Pool Dimensions.**

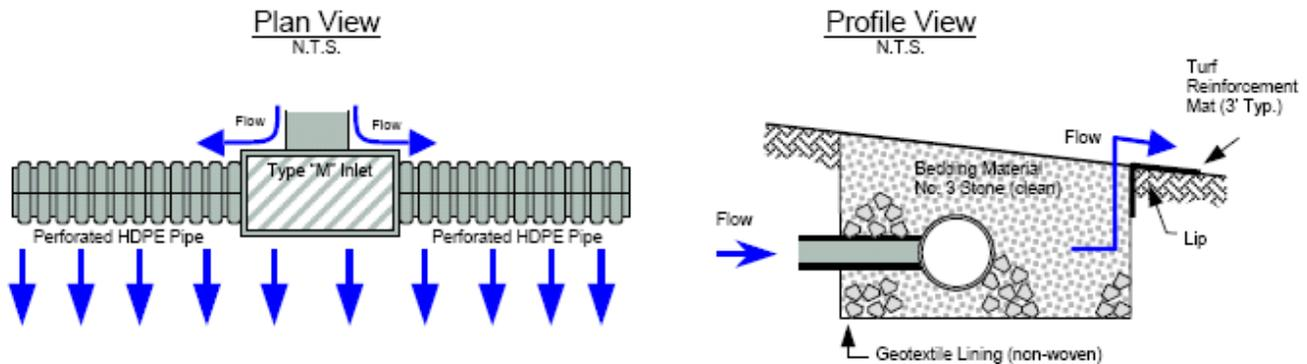


b. Accommodate draining the plunge pool (surface discharge):

- i. To preserve infiltration capacity, the underlying soils should remain undisturbed, uncompacted, and protected from heavy equipment.
- ii. If standing water in the plunge pool is a potential issue (e.g., mosquitoes, icing, etc.), the level spreader should include a drainpipe with a discharge point located in a well-vegetated area and/or include soil stabilization measures, as appropriate. (See **Figure G.3**) A **2-inch** diameter drainpipe is recommended with a minimum **1% slope**. Where possible, installation of the drainpipe should extend laterally so that the discharge point is located outside of the flow path of the level spreader. Where this is not possible, installation by trench method should be avoided since it may create a preferential seepage pathway for surface flow and erosion. In certain instances, the drainpipe (ductile iron) may be driven horizontally with a sledgehammer.

- c. For subsurface discharge level spreaders (no plunge pool):
  - i. When installing perforated pipe (level), area should be carefully excavated into the existing grade to maintain a level lip. A rigid lip may also be utilized, as appropriate.
  - ii. Turf Reinforcement Mat should be installed for minimum of **3 feet** down slope of lip.
  - iii. Perforated pipes should include end treatments consisting of clean-outs or Type M inlets, which can also help accommodate future maintenance.
  - iv. Select non-woven geotextile lining based on soil type (sands, silts, clays, etc.).

**Figure G.5. Typical Orientation of Level Spreader with Subsurface Discharge**

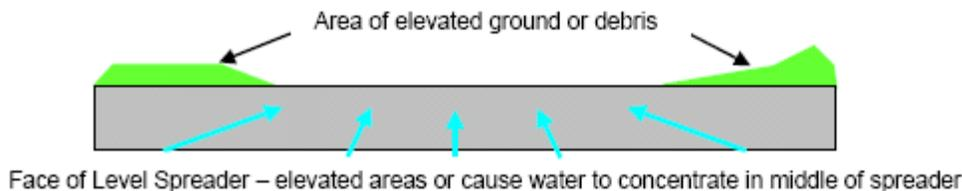


7. Soil Stabilization Issues: The area down slope of the level spreader should be undisturbed. At a minimum, the first **three feet** down slope from a level spreader should be stabilized with soil/turf reinforcement mat and the area should be stabilized with grass or other approved vegetation. There should be a minimum uniform ground cover of **90%**. If vegetation along the flow path is insufficient, it should be enhanced to maximize erosion protection prior to any discharges. If a level spreader is installed above a disturbed area without a good vegetative cover, erosion rills can quickly form. Even sheet flow can cause significant erosion on disturbed areas. (See **Section IX**)
  - a. Because of the possibility of high-prolonged discharge from structural level spreaders, the area in the immediate vicinity of the discharge should be properly stabilized. Such stabilization may include rigid measures (stone, riprap, etc.) to help protect surrounding vegetation. (see Profile View of **Figure G.3**)
  - b. Level spreaders are **not** intended for sediment removal. Significant sediment deposition in a level spreader will considerably reduce its effectiveness. During construction, suitable erosion and sediment pollution control BMPs should be utilized upslope of level spreaders. This aside, maintenance measures would still be required both during construction and after the drainage area is stabilized, including replacement of bedding material and geotextile stabilization (if applicable). In these instances, it would be preferable for the discharge pipe to be at the surface rather than subsurface.
  - c. The down slope side of the level spreader should be clear of elevated ground and debris.
    - i. Elevated areas need to be carefully graded to create a smooth transition; backfilling is not recommended.
    - ii. Another potential problem after construction is debris such as earth, wood, and other organic matter that may accumulate immediately down slope of the level spreader.

Both of these situations effectively block water as it tries to flow over the level spreader and may force it to quickly re-concentrate. (See **Figure G.6**)

- d. Consider the time of year available for proper establishment of vegetation prior to construction of the level spreader. Temporary stabilization may be achieved in sparsely vegetated areas with a compost blanket (min. 3"). If a grass cover needs to be re-established in the receiving area construction may be limited to the growing season.

**Figure G.6. View of Level Spreader Face Looking Downslope**



Source: *Evaluation of Level Spreaders in the Piedmont of North Carolina*

8. **Operation and Maintenance (O&M):** Because of construction-related problems, the performance of level spreaders should be monitored for **2 years** on a **quarterly basis** and **semi-annually** thereafter. Inspections should also be made following rainfall events exceeding **1-inch**. Prior to placing the level spreader into service, a qualified professional, preferably the designer should inspect the structure once it is fully constructed so that necessary adjustments or repairs can be made before the contractor leaves the site. Routine monitoring and maintenance is already a requirement of both the E&S Plan and the Post Construction Stormwater Management Plan. Monitoring includes both the level spreader and the down slope area, up to and including the receiving stream (See **Section VI.3, Authorization from Off Site Property Owners**).
- a. Monitoring should be documented in inspection reports submitted to the conservation district along with a summary of any repairs or adjustments completed. Modifications may need prior approval. As-built drawings should be submitted by the end of the 2-year monitoring period verifying that the level spreader was built as designed and performing as intended.
- b. The conservation district and township engineer should be notified during key stages of construction (including the construction of a level spreader) to allow for site inspections at their discretion.
- c. A long term O&M plan should be prepared, in conjunction with all proposed stormwater BMPs, identifying:
  - 1) Who will be responsible,
  - 2) What O&M procedures are planned and
  - 3) When these measures will be performed (frequency).
    - i. Include provisions for replacing components surpassing their useful life.
    - ii. Periodic cleaning out of sediment that is expected to accumulate over time to maintain its capacity.
- d. Erosion and Sediment (E&S) Control consideration: As mentioned in **Item 7**, level spreaders should not be used as a primary E&S BMP. When used down slope of a sediment basin/trap, it should be off-line during construction or (where applicable) the bedding material and geotextile lining should be replaced after the drainage area is stabilized.

- e. Level spreaders should be located only where safe and legal ingress and egress can be obtained for post-construction inspection and maintenance.

## **VI. LEGAL CONSIDERATIONS**

1. Adequacy of Off-Site Discharge: (also see **Item 3**, *Authorization from Off-site Property Owners*)  
The developer/designer will need to demonstrate that the proposed construction and/or post-construction stormwater discharge will not cause erosion or damage down slope and to any adjoining properties. Therefore, designs involving off-site stormwater discharge to non-surface waters should include the following information:
  - a. A written analysis, entitled "**Adequacy of Off-Site Discharge**" signed and sealed by a licensed professional engineer that clearly, concisely, and accurately describes the situation along with any supporting computations, etc.
    - i. The written analysis should include an evaluation of existing land cover, vegetative species (and their condition), topography, geology, down slope property owners, etc., and a description of the soils erodibility and absorption characteristics.
    - ii. This analysis cannot be achieved solely through a desktop review; a site visit is required.
    - iii. A copy of this written analysis should be included both in the narrative and on the plan drawings in the event these documents are separated.
    - iv. Where there is a discharge onto or through adjacent properties prior to release to a stream, designers should demonstrate how down slope properties will be protected.
  - b. A plan drawing detailing the flow path from discharge point to confluence with a surface water of the Commonwealth and identifying the soil types, erodibility factors, and consideration of vegetative cover.
  - c. Sequential color photos of the entire proposed flow path with a map showing the location and orientation of each photo. Plan should include the location and orientation of each photo.
  - d. A contingency plan and agreement should be prepared to deal with damages from the level spreader that may occur down slope (including parcels owned by others). The applicant may also set aside funds in escrow for this purpose. This would be at the discretion of the municipality. (Also see **Item 3**)
  - e. The minimum distance between a proposed discharge point (including the level spreader) and a down slope property boundary should be a minimum of **fifteen (15) feet**. (CCWRA, 2005) The regulating authority(ies) may require that the setback distance be increased based upon factors such as accessibility, topography, soil conditions, the size of structures, the location of structures, and discharge rates. A drainage easement may also be required. (See **Item 3**)
2. Municipal Coordination:  
The municipality has a key role in stormwater management, including the use of level spreaders. The following criteria should be used to ensure the municipality's role, particularly when there is an issue encountered with an off-site discharge:
  - a. The municipal engineer should be contacted by the applicant early in the process to open the lines of communication.

- b. A copy of the written analysis (described in **Item 1**) should be submitted to the municipal engineer by the applicant.
  - c. The municipality should provide a letter verifying the project's consistency with applicable local ordinances, a copy of which should be submitted to other reviewing agencies with any permit applications.
3. Authorization from Off-site Property Owner(s):  
In cases involving discharges to off-site properties where a point-source discharge did not previously exist, the developer/consultant will need to:
- a. Document property owner(s) consent through easement, right-of-way or other acceptable documentation.
  - b. Document property owner(s) consent to access and repair any erosion or other damages that may occur in the future. In some cases, a level spreader will not be feasible and the only option the applicant will have is to reach an agreement with the off-site property owner to construct a conveyance (i.e., a pipe or channel) to an adequate discharge point. (See **Section VIII, Outfall Design**) DEP is also in the process of developing a related fact sheet, which may provide further guidance on the issue.

## **VII. LEVEL SPREADER DESIGN CONSIDERATIONS**

The primary reference of the information in this section has been taken from *Designing Level Spreaders to Treat Stormwater Runoff*. (W.F. Hunt, D.E. Line, R.A. McLaughlin, N.B. Rajbhandari, R.E. Sheffield; North Carolina State University, 2001)

### **Maximum Flows**

The maximum allowable flow that a level spreader effectively distributes is a function of:

1. The ability to slow down the inflow before it flows over the level spreader and;
2. The length of the level spreader.

If the plunge pool is a small stormwater pond and the level spreader is several hundred feet long then the maximum flow allowed to spill over a level spreader is considerably high. To avoid failures, the plunge pool should be designed with a length (**X**) sufficient to dissipate the energy of inflows prior to reaching the weir crest of the level spreader. (See **Section V.6** and **Figure G.3**) This is dependent on the inflow velocity.

### **Design Storms**

For the purposes described in this paper, level spreaders should be constructed to effectively diffuse anticipated flows up the **100-year storm**. For this reason, these structures should be limited in their drainage areas. (**5 acres maximum**) Level spreaders may be multi-functional and can incorporate both water quality treatment and infiltration as part of a treatment train - but since these facilities are located at the tail end of the train, they should not be a primary BMP.

The length of the level spreader is primarily determined by peak flow rate. There are many methods that are commonly used to determine peak flow from small watersheds, including the NRCS Soil Cover Complex Method (a.k.a. Curve Number Method). Peak rate computations are commonly dictated by local ordinance and this paper will not cover those computations.

### **Design to Avoid Downstream Erosion**

Down slope conditions are also essential when determining allowable flows and the length of level spreader, in particular, the existing soil cover (e.g., grass, mulch, or a thicket.)

## Allowable Velocities

The maximum allowable velocity is a function of ground cover. The maximum allowable velocities for down slope soil covers are listed in **Table G.1**. Please note that tree and shrub riparian buffer is assumed to have a mulch ground cover (or no ground cover).

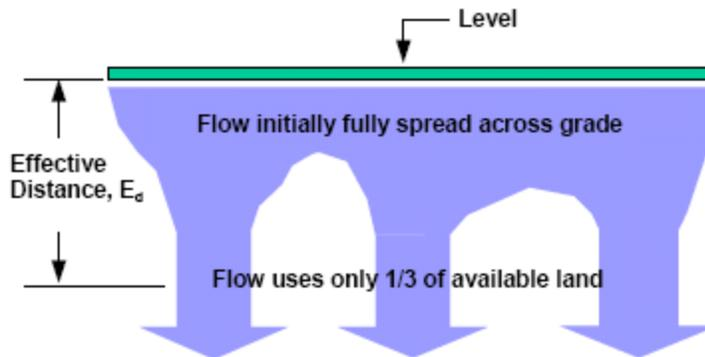
**Table G.1. Allowable Velocities for Downslope Covers for Channeled Flows**

Ground Cover	Allowable Velocity
Grass*	4 fps
Gravel	5 fps
Mulch	1-2 fps

\* See E&S Manual for more information on permissible velocities for grass and other cover types. Allowable velocities for grass can vary from 2.5 fps to as much as 8 fps. 4 fps has been selected as a conservative figure for design purposes.

The level spreader length needs to be designed so that the allowable velocity is not exceeded. It is important that the design consider that water will recollect as it flows down slope. Studies have shown that water distributed across a grade may recollect in as little as **10-12 feet**. Because recollection is inevitable, the amount of area needed for concentrated flow to develop should be estimated. How much recollection is allowable until flow can no longer be considered sheet flow? Sheet flow becomes concentrated flow once water is using only **33%** of the available land in the flow path (Hunt et al, 2001). Refer to **Figure G.7**. The distance down slope of the level spreader where only **33%** of available land is used can be described as the level spreader's effective distance, or  $E_d$ . Flow beyond the level spreader's effective distance would be considered to be concentrated flow, not sheet flow.

**Figure G.7. Concentration of Flow Down Slope of Level Spreader**



Source: *Designing Level Spreaders to Treat Stormwater Runoff*

Therefore, level spreaders should be designed to ensure non-erosive velocities not only at the time water passes over the level spreader (when flow is theoretically completely dispersed), but also at the time water has reached the Effective Distance. The latter being the limiting parameter (i.e., erosive velocities are not exceeded once the flow has traveled the effective distance.). As such, discharge velocities from level spreaders should be **33%** or less of the allowable down slope velocities based on cover. As an example, if a mulch ground covering is able to withstand velocities as high as 2 feet per second (fps), then the level spreader discharge velocity should be 0.67 fps, or 1/3 of the erosive velocity. If the vegetation/ground cover along the flow path is insufficient to protect against erosion, then it should be enhanced to maximize erosion protection.

## Calculating Level Spreader Length

The designer's main goal for level spreaders is to ensure an appropriate length of the discharge feature - a length that does not allow for erosive velocities down slope. Allowable velocities over a level spreader are summarized in **Table G.2**. The designer can also find more information on allowable velocities (a.k.a.

permissible velocities) and other criteria for ground cover from Tables 6.2 through 6.4 related to: *Maximum Permissible Shear Stresses for Various Channel Liners* and *Maximum Permissible Velocities for Channels Lined with Vegetation*.

### Using Allowable Velocities to Establish Level Spreader Length

With an allowable velocity selected based upon down slope ground cover, it is now possible to calculate the necessary level spreader length. The calculation is based on two equations: (1) the Weir Equation and (2) the Continuity Equation, both of which are described below.

Weir Equation: It is assumed that the level spreader functions as a long weir. Flow over a weir is described by the following equation and illustrated in **Figure 8**.

$$Q = C_w * L * H^{3/2}$$

Where

Q = Flow (cfs)

L = Length of Level Spreader (feet)

C<sub>w</sub> = Weir Coefficient (assume 3.0)

H = Driving Head (feet)

Flow over the level spreader is a function of its length and the height of water upslope. Increasing the length of the weir reduces the height of water for a given flow rate, as they are directly related. This is important because the combination of water height and weir length dictate the level spreader discharge velocity. This relationship is shown in the second equation, the continuity equation.

Continuity Equation:

$$Q = V * A$$

Where

Q = Flow (cfs)

V = Velocity (feet)

A = Cross-Sectional Area of Flow (ft<sup>2</sup>) = L \* 2/3H

Again, the allowable velocity is selected based on the type of cover down slope of the level spreader (e.g., grass, gravel, mulch). Therefore, the above two equations can be combined to solve for V as follows:

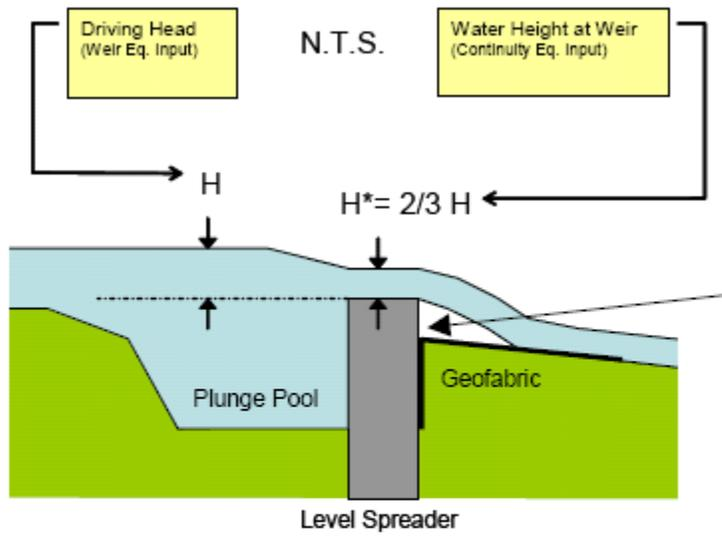
$$V = 1.5 * C_w * H^{1/2}$$

Using the above equation, the height of water above the weir may be calculated. The resulting height would then be inserted into the weir equation to calculate the length of level spreader needed to distribute a given flow.

**Table G.2. Maximum Velocities of Flow Across Level Spreader**

Down Slope Ground Cover	Velocity at Level Spreader V (fps)	Driving Head H (feet)	“Equivalent” Water Height over Level Spreader, $H^*=2/3H$
Grass/Thicket	1.33	0.09	0.058
Gravel	1.50	0.11	0.074
Mulch (Trees, Shrubs)	0.67	0.02	0.015

**Figure G.8. Weir Equation Inputs**



Source: *Designing Level Spreaders to Treat Stormwater Runoff*

**Note:** There should be a smooth transition between the level spreader and native ground. Ideally, the lip of the concrete level spreader should be no higher than 3 - 4 inches above the existing ground. This would allow water to pass over the lip without interference from vegetation. See Section V and Figure 3.



**Table G.3. Level Spreader Lengths for Various Downslope Covers and Discharges**

Q (cfs)	Gravel L (ft)	Grass/Thicket/Shrubs L (ft)	Mulch** or No Cover L (ft)	Using equation $L = Q / (C_w * H^{3/2})$ Notes:
0.5	5*	6*	59	
1.0	9*	13	118	
1.5	14	19	177	
1.7	16	21	200	Mulch Limit**
2.0	18	25	N/A	
3.0	27	37		
4.0	37	49		
5.0	46	62		
10.0	91	123		
15.0	137	185		
16.0	146	198		
16.2	148	200		Grass/Shrub/Thicket Limit
20.0	183	N/A		
21.0	192			
21.9	200		Gravel Limit	

\* use min. length of 10 feet  
 \*\* see below suggestions regarding forested areas

Source: *Designing Level Spreaders to Treat Stormwater Runoff*

As mentioned in **Section V.4c** other guidance documents, including the *BMP Manual*, recommend **13 linear feet** of level spreader per **1 cfs** of flow. As can be seen in **Table G.3** above, this is consistent for the condition when there is excellent vegetative ground cover down slope. (i.e. thicket/shrubs/grass) It also assumes that there are no existing erosion problems down slope. It is not uncommon to find areas of lush vegetation followed by an area of sparse vegetation. It is crucial that designers perform a thorough site assessment and not use this as a general rule of thumb for all conditions. The most controlling factor is the allowable velocity, which should be based on the worse case down slope ground cover condition. The designer would need to verify the condition of the ground cover for the entire slope up to the receiving stream, preferably in the winter. An alternative would be to improve the down slope area to achieve the design cover condition - prior to discharge.

The results of recent research (Hathaway and Hunt, 2006) has suggested that wooded riparian buffers having a good mulch cover exhibit positive features such as absorption and infiltration which are often ignored. For the purposes of this paper, a good mulch cover should measure a minimum **3 inches** thick. When these attributes within the buffer are taken into account and documented during a site assessment, the length of level spreader per unit of flow may be reduced. This reduction can be significant due to the long lengths of level spreader required for the "mulch/no cover condition" - i.e. 100 linear feet/cfs. Based on this information, the recommended design length of level spreader can be reduced as follows, in relation to riparian buffer width and the dominant hydrologic soil group (HSG) for the down slope area:

**Table G.4. Reduced Level Spreader Lengths for Wooded Riparian Buffers**

Wooded Riparian Buffer Width (ft)	HSG A or B	HSG C or D
	Length of Level Spreader per CFS of flow (ft)	
50	65	80
100	50	70
150	40	55

Source: *Evaluation of Level Spreaders in the Piedmont of North Carolina.*

**VIII. OUTFALL DESIGN**

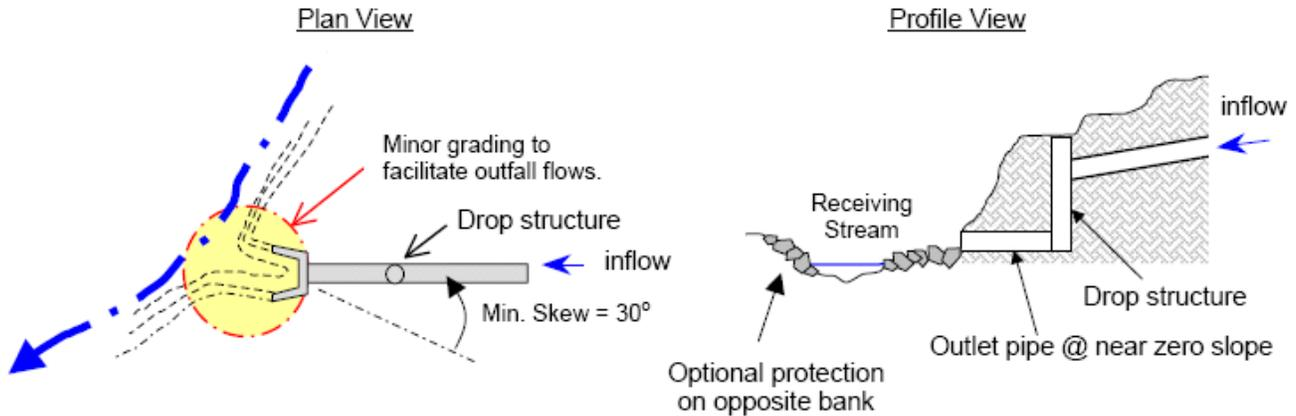
As previously mentioned, if it is determined that a level spreader is not feasible for a project, the developer will need to modify the project to either avoid the conflict or to convey the point source discharge to a surface water or storm sewer which is capable of handling anticipated flows. This is typically done by extending a conduit through the area and terminating at a watercourse with an outfall structure. Outfall structures are regulated as water obstructions pursuant to the Chapter 105 Regulations - *Dam Safety and Waterway Management*. (July 1, 1979, revised October 12, 1991) Permitting may fall under the following categories:

- **Waiver - 105.12(a)(2)** - If the receiving stream has a drainage area less than **100 acres**.
- **General Permit No. 4** - In most cases, the project will qualify for a GP but the applicant would be responsible for making sure they meet the eligibility requirements and conditions.
- **Joint Permit** - Outfalls not qualifying for a waiver or GP will need a Joint Permit. For more information, refer to the Pennsylvania Chapter 105 Joint Application for a Water Obstruction and Encroachment Permit.

Experience has shown that many stormwater plans have been proposed in a manner discharging into upland areas to avoid Chapter 105 - Water Obstruction and Encroachment Permitting. These proposals are typically unacceptable unless they are being prepared to protect a riparian buffer or wetland, in which case, a typical level spreader design might be appropriate. (See illustration in **Section II**) Under no circumstances should a point source be discharged above the floodway and allowed to scour a channel down to the watercourse. In these instances, the designer should extend the outfall to the edge of the stream and take into account the following factors:

1. Orientation of the outfall with respect to the flow direction of the stream. Rather than be positioned perpendicular to the stream, the outfall should be designed at a skew of **30°** or more to maintain harmonious stream current and to avoid scouring the opposite stream bank during high flows. Depending on the size of the receiving channel, it may be necessary to install protective measures on the opposite bank. Note that there should be no riprap placed in the stream bed.
2. The size of the outfall should be commensurate with the size of the receiving stream and should not over-burden the stream and thereby cause downstream erosion.
3. The outfall conduit should, wherever possible, go through a drop structure to dissipate the energy in the pipe, rather than relying on riprap at the end of the pipe. The outfall pipe should have a slope at or near **zero**.
4. Where riprap is appropriate, it should be keyed into the ground as opposed to piled in front of the outfall, which creates a flow obstruction. Riprap should not extend across the stream channel or cause an obstruction of stream flows. Refer to **General Permit No. 4** for further guidance.

**Figure G.9. Outfall Layout**



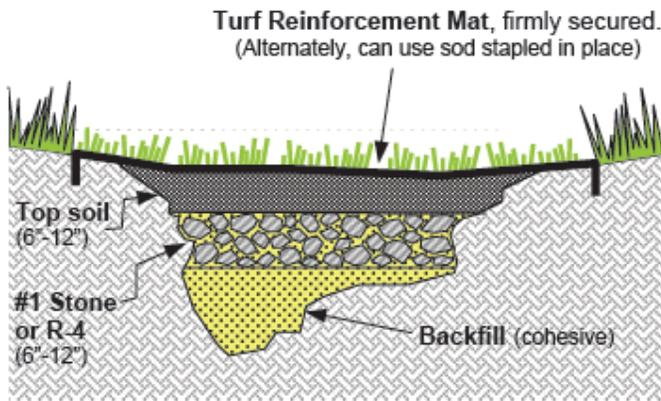
## **IX. REMEDIAL ACTIONS**

As previously mentioned in **Section VII**, *water will recollect as it flows down slope and recollection is inevitable*. The design and planning recommendations in this paper are intended to avoid issues with failures and gully/rill formation, but plans also need to be in place for when any such unfortunate events may occur.

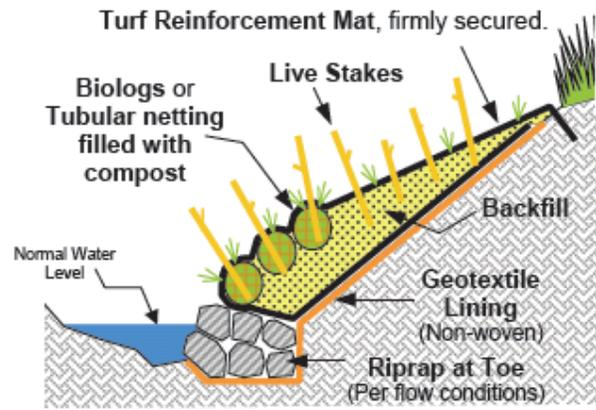
One of the most common problems experienced with level spreaders is the formation of rills, which if left unattended can become gullies. Rills that exceed **3 inches** in depth may be considered gullies. The most important point here is to identify and address these problems early by following these simple steps: (1) stop the erosion, (2) repair the damage, and (3) prevent future damage.

It is best to redirect flow away from the affected area until repairs can be completed and the area stabilized. This can be accomplished by a temporary slope pipe or other diversion, but care should be taken not to create erosion problems elsewhere. Seasonal variations are also an issue, particularly with permanent stabilization/revegetation. As discussed in **Section VI.7**, a minimum uniform cover of **90%** is required to protect down slope areas. Care should be taken throughout the flow path, up to the receiving stream. A level spreader should never discharge to a disturbed area until vegetative cover is established.

**Figure G.10. Rill/Gully Repair**



**Figure G.11. Stream Bank/Gully Repair**

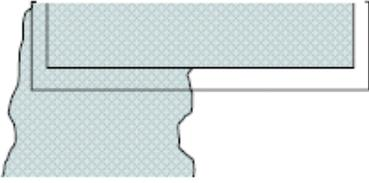
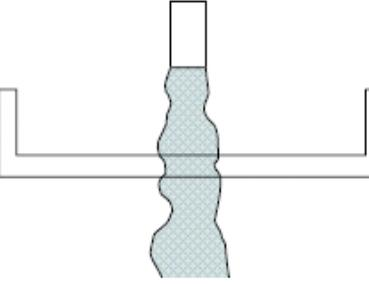
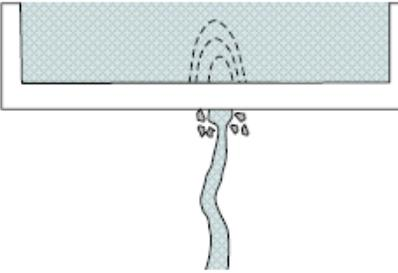
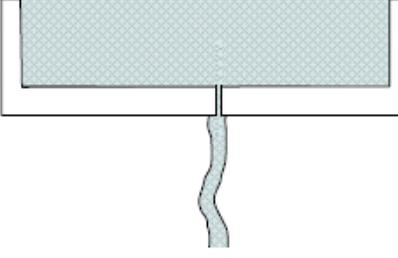


Source: Filtrexx - Edgesaver

Rills and/or gullies can express themselves anywhere along the flow path. In some instances, they appear at the stream bank. Stream banks are susceptible to erosion from a variety of sources and directions. Accelerated erosion along a stream bank is normally due to the stream geometry being out of equilibrium with its watershed, which is beyond the control of the plan designer. As water passes over a denuded stream bank, a head cut can form and travel from the stream into the buffer. The plan designer should ensure that an exposed stream bank does not exist along the flow path. If so, there are a variety of stream bank stabilization methods, including traditional "hard engineering" techniques, such as riprap; softer techniques such as "bioengineering slope stabilization" or a combination of the two. See **Figure G.11** above. For more details, the designer may reference **General Permit No. 3** or various references for bioengineering such as Chapter 18 of the *NRCS, Engineering Field Handbook* available at [www.info.usda.gov/CED/ftp/CED/EFH-Ch18.pdf](http://www.info.usda.gov/CED/ftp/CED/EFH-Ch18.pdf). The goal is to create a natural and stabilized system that doesn't require any significant long-term maintenance. There are a variety of "green" and environmentally-friendly products available on the market which can be utilized jointly with bioengineering techniques to provide quality results.

Experience has shown that there are many other potential factors leading to level spreader failure, many of which have been covered through the recommendations in this paper. A list of common failures, potential causes and suggested fixes are provided in **Figure G.12**. When necessary, a level spreader may be replaced with a stable conveyance and outfall to a surface water feature or to a storm sewer capable of carrying those flows. This subject was previously discussed in various places, including **Section VIII**.

**Figure G.12. Common Level Spreader Failures**

<p style="text-align: center;"><u>Unlevel</u></p> 	<p><u>Cause:</u></p> <ul style="list-style-type: none"> <li>•Differential Settlement</li> <li>•Frost Heaving</li> <li>•Poor Construction</li> </ul>	<p><u>Fix:</u></p> <ul style="list-style-type: none"> <li>•Rebuild</li> <li>•Retrofit               <ul style="list-style-type: none"> <li>•Affix a level plate/weir on down slope (d/s) end</li> </ul> </li> </ul>
<p style="text-align: center;"><u>Short Circuiting</u></p> 	<p><u>Cause:</u></p> <ul style="list-style-type: none"> <li>•Poor Planning</li> <li>•Poor Construction</li> </ul>	<p><u>Fix:</u></p> <ul style="list-style-type: none"> <li>•Retrofit               <ul style="list-style-type: none"> <li>•Extend concrete ends upslope and key-in</li> <li>•Repair erosion and revegetate d/s</li> </ul> </li> </ul>
<p style="text-align: center;"><u>Overtopping</u></p> 	<p><u>Cause:</u></p> <ul style="list-style-type: none"> <li>•Poor horizontal and/or vertical alignment</li> <li>•Inadequate plunge pool length/depth</li> <li>•Weir too close to outlet pipe.</li> </ul>	<p><u>Fix:</u></p> <ul style="list-style-type: none"> <li>•Rebuild</li> <li>•Retrofit               <ul style="list-style-type: none"> <li>•Construct raised middle section to divert flow and block overtopping</li> <li>•Pull back outlet pipe</li> </ul> </li> </ul>
<p style="text-align: center;"><u>Undercutting</u></p> 	<p><u>Cause:</u></p> <ul style="list-style-type: none"> <li>•Poor construction</li> <li>•Inadequate weir invert</li> <li>•Inadequate depth of footer</li> <li>•Constructing on fill</li> <li>•Vandalism</li> </ul>	<p><u>Fix:</u></p> <ul style="list-style-type: none"> <li>•Rebuild</li> <li>•Retrofit               <ul style="list-style-type: none"> <li>•Flowable fill u/s</li> <li>•Repair erosion and revegetate d/s</li> <li>•Protect from unauthorized acts</li> </ul> </li> </ul>
<p style="text-align: center;"><u>Failed Joint</u></p> 	<p><u>Cause:</u></p> <ul style="list-style-type: none"> <li>•Poor construction</li> <li>•Inadequate joint filler</li> <li>•Vandalism</li> </ul>	<p><u>Fix:</u></p> <ul style="list-style-type: none"> <li>Retrofit               <ul style="list-style-type: none"> <li>•Plate or weir</li> <li>•Install proper joint filler resistant to freeze/thaw</li> <li>•Repair erosion and revegetate d/s</li> <li>•Protect from unauthorized acts</li> </ul> </li> </ul>

## **X. SELECTED REFERENCES**

*Pennsylvania Stormwater Best Management Practices Manual* (PA DEP, December 30, 2006)

*Pennsylvania Erosion and Sediment Pollution Control Manual* (PA DEP, March 2000)

*Designing Level Spreaders to Treat Stormwater Runoff* (W.F. Hunt, D.E. Line, R.A. McLaughlin, N.B. Rajbhandari, R.E. Sheffield; North Carolina State University, 2001)

*Level Spreader Design Guidelines-Final Version* (C. F. Van Der Wiele, North Carolina Department of Environment and Natural Resources, Division of Water Quality, Effective January 1, 2007)

*Evaluation of Level Spreaders in the Piedmont of North Carolina- Final Report* (Jon Hathaway, EI and William F. Hunt PE, PhD, Department of Biological and Agricultural Engineering, North Carolina State University- July 2006)

*Urban Waterways - Level Spreaders: Overview, Design and Maintenance.* (Jon Hathaway, EI and William F. Hunt PE, PhD, Department of Biological and Agricultural Engineering, North Carolina State University-Cooperative Extension Office -November 2006)

*Post-Construction SWM Model Ordinance* (Chester County Water Resources Authority, January 4, 2005)

*Standard Drawing No. IL-570* (USDA, NRCS, Illinois Urban Manual, January 29, 1999)

*Level Spreader Effectiveness Evaluation, Final Report* (Caltrans, May 2002)

*Design and Long Term Performance of an Innovative Level Spreader Basin Outfall Structure,* (Eric S. Steinhauser and Owen Esterly - World Water Congress 2003).

*Effectiveness and Cost of Improving Vegetated Filter Zones by Installing Level Spreaders to Disperse Agricultural Runoff.* (Dennis William Hazel, Doctoral Thesis, North Carolina State University- 2000)

Internet References:

[www.therockerbox.com/how\\_to\\_use\\_a\\_map\\_5.htm](http://www.therockerbox.com/how_to_use_a_map_5.htm)

[www.info.usda.gov/CED/ftp/CED/EFH-Ch18.pdf](http://www.info.usda.gov/CED/ftp/CED/EFH-Ch18.pdf)

## **XI. ACKNOWLEDGEMENTS**

The author will like to thank the Technical Work Group for their time and valuable input, including but not limited to:

Bucks County Conservation District - Lisa Ishimuro, Eric Wightman

Chester County Conservation District - Dan Greig, Gaye Lynn Criswell

Delaware County Conservation District - Ed Magargee

Lehigh County Conservation District - John Bohman, Kevin Frederick

Montgomery County Conservation District - Rich Kadwill, Jeff McKenna, Mike Shannon

PA DEP - Stephen Burgo, Ana Damerau, Stuart Demanski, James Newbold, Jeffrey Sholly, Dennis Stum

PA DOT - Tim Stevenson, Sharon Goldberg

Special thanks also to the numerous peer reviewers for their time and helpful feedback, including:

Jonathan Hathaway - North Carolina State University

Jonathan Hunt - River Valley Organics

Eric Konzelmann - Castle Valley Consultants

Robert Lambert - Site Engineering Concepts, LLC

Jeffrey MacKay - NTM Engineering, Inc.

Jonathan Rinde - Manko, Gold, Katcher and Fox  
 Darl Rosenquest - PADEP - Western Area Engineer  
 Eric Steinhauser - Sanborn, Head and Associates  
 Robert Traver - Villanova University

**Checklist for Designing Level Spreader Discharges**

Project Name: _____
Project No.: _____
Location: _____
Date: _____

Prior considerations:

- Avoid and minimize discharge to non-surface waters
- Consider less impacting alternatives
- Maximize volume control BMPs throughout the site
- Prevent concentrating flow

Site Evaluation/Limitations:

- Site Assessment performed to determine site constraints (including a **site visit**)
- Level area – along existing contour

Have fully evaluated and considered:

- |   |  |
|---|--|
| <input type="checkbox"/> Topography       | <input type="checkbox"/> Soil type(s)        |
| <input type="checkbox"/> Vegetative cover | <input type="checkbox"/> Geologic conditions |

Meets optimum conditions:

- Land surface shape
- Max. Soil slope = \_\_\_\_%
- Slope length = \_\_\_\_\_ ft.

H&H Considerations:

- Designed for 100-year storm.  $Q_{100} =$  \_\_\_\_\_ cfs
- Drainage Area  $\leq$  5 acres
- Suitable weir length using guidance in Section V.  $L =$  \_\_\_\_\_ ft.
- Not exceeding 200 feet long
- Inflow less than 1% slope
- Proper Lip - Rigid Lip, if  $Q > 4$ cfs
- Smooth transition – both inflow and outflow.
- Proper orientation – T-shaped
- Infiltration capacity preserved

Avoids short-circuiting and/or overloading

- Sufficient  $X =$  \_\_\_\_\_',  $Y =$  \_\_\_\_\_', and  $h =$  \_\_\_\_\_'. (surface discharges)
- Optional Raised Section (surface discharges)
- Ends keyed upslope (surface discharges)
- Includes adequately sized riprap (surface discharges)
- Equipped to drain the plunge pool
- Includes end treatments on perforated pipe. (subsurface discharges)
- Includes fabric or TRM on down slope (both surface and subsurface)

Soils Stabilization Issues:

- Located on undisturbed ground (no fill)
- Achieves minimum of 90% vegetative cover down slope
- Includes rigid measures to prevent erosion just below
- Down slope area clear of elevated ground, debris or any other obstructions

Other Items:

- O&M Considerations per **Section V.8.**
- "Adequacy of Off-Site Discharge" Analysis completed per **Section VI.1.**
- Municipal Coordination per **Section VI.2.**
- Authorization from Off-Site Property Owner(s) per **Section VI.3.**
- Outfall Design, if applicable, per **Section VIII.**

## APPENDIX H - DUST CONTROL



### Description

Dust control measures are practices that help reduce surface and air movement of dust from disturbed soil surfaces. Construction sites are good candidates for dust control measures because land disturbance from clearing and excavation generates a large amount of soil disturbance and open space for wind to pick up dust particles. To illustrate this point, limited research at construction sites has established an average dust emission rate of 1.2 tons/acre/month for active construction (WA Dept. of Ecology, 1992).

These airborne particles pose a dual threat to the environment and human health. First, dust can be carried off-site, thereby increasing soil loss from the construction area and increasing the likelihood of sedimentation and water pollution. Second, blowing dust particles can contribute to respiratory health problems and create an inhospitable working environment.

### Applicability

Dust control measures are applicable to any construction site where dust is created and there is the potential for air and water pollution from dust traveling across the landscape or through the air. Dust control measures are particularly important in arid or semiarid regions, where soil can become extremely dry and vulnerable to transport by high winds. Also, dust control measures should be implemented on all construction sites where there will be major soil disturbances or heavy construction activity, such as clearing, excavation, demolition, or excessive vehicle traffic. Earthmoving activities are the major source of dust from construction sites, but traffic and general disturbances can also be major contributors (WA Dept. of Ecology, 1992). The particular dust control measures that are implemented at a site will depend on the topography and land cover of a given site, as well as the soil characteristics and expected rainfall at the site.

### Siting and Design Considerations

When designing a dust control plan for a site, the amount of soil exposed will dictate the quantity of dust generation and transport. Therefore, construction sequencing and disturbing only small areas at a time can greatly reduce problematic dust from a site. If land should be disturbed, additional temporary stabilization measures should be considered prior to disturbance. A number of methods can be used to control dust from a site. The following is a brief list of some control measures and their design criteria. Not all control measures will be applicable to a given site. The owner, operator, and contractors responsible for dust control at a site will have to determine which practices accommodate their needs based on specific site and weather conditions.

- **Sprinkling/Irrigation.** Sprinkling the ground surface with water until it is moist is an effective dust control method for haul roads and other traffic routes (Smolen et al., 1988). This practice can be applied to almost any site.
- **Vegetative Cover.** In areas not expected to handle vehicle traffic, vegetative stabilization of disturbed soil is often desirable. Vegetative cover provides coverage to surface soils and slows wind velocity at the ground surface, thus reducing the potential for dust to become airborne.
- **Mulch.** Mulching can be a quick and effective means of dust control for a recently disturbed area (Smolen et al., 1988).
- **Wind Breaks.** Wind breaks are barriers (either natural or constructed) that reduce wind velocity through a site and therefore reduce the possibility of suspended particles. Wind breaks can be



trees or shrubs left in place during site clearing or constructed barriers such as a wind fence, snow fence, tarp curtain, hay bale, crate wall, or sediment wall (USEPA, 1992).

- Tillage. Deep tillage in large open areas brings soil clods to the surface where they rest on top of dust, preventing it from becoming airborne.
- Stone. Stone may be an effective dust deterrent for construction roads and entrances or as a mulch in areas where vegetation cannot be established.
- Spray-on Chemical Soil Treatments. The Pennsylvania Dirt and Gravel Road Program has placed strict limitations on the use of products that may cause damage to the environment. With this in mind, it has approved a number of chemical dust suppressants. When considering chemical application to suppress dust, consideration should be taken as to whether the chemical is biodegradable or water-soluble and what effect its application could have on the surrounding environment, including waterbodies and wildlife.

Table H.1 shows application rates for some common dust suppressants, as recommended by the Pennsylvania Dirt and Gravel Road Program. Refer to the website at [www.dirtandgravelroads.org](http://www.dirtandgravelroads.org) for updated information about approved products and application rates. **NOTE: The Department does not endorse these or any other individual products.**

**Table H.1. Application Rates for Dust Suppressants**

Product	Water Dilution	Type
Penn Suppress "D"	1:4 emulsion to water (Minimum)	Petroleum Emulsion
Ultrabond 2000	1:4 emulsion to water (Minimum)	Petroleum Emulsion
Coherex	1:10 emulsion to water (Minimum)	Petroleum Emulsion
Dust Bond	1:10 emulsion to water (Minimum)	Petroleum Emulsion
EK 35	100% active, not water required for application	Synthetic Fluid
EnviroKleen	100% active, not water required for application	Synthetic Fluid
Pave-Cyrl Suppress	As-received (51% solids)	Acrylic Polymer (PVA)
Pave-Cyrl Suppress Plus	As-received (51% solids)	Acrylic Polymer (PVA)
DirtGlue	As-received (>51% solids)	Acrylic Polymer (PVA)

Other suppressants may be used as long as they have been shown to be environmentally safe and effective for the intended use. Table H.2 provides information regarding the types of suppressants commonly used.

**Table H.2. Adhesives Used for Dust Control**

<b>Adhesive</b>	<b>Water Dilution (Adhesive: Water)</b>	<b>Type of Nozzle</b>	<b>Application Rate Gallons/Acre</b>
Anionic Asphalt Emulsion	7:1	Coarse Spray	1,200
Latex Emulsion	12.5:1	Fine Spray	235
Resin in Water	4:1	Fine Spray	300
Acrylic Emulsion (Non-Traffic)	7:1	Coarse Spray	450
Acrylic Emulsion (Traffic)	3.5:1	Coarse Spray	350

VA. DSWC

### **Limitations**

In areas where evaporation rates are high, water application to exposed soils may require near constant attention. If water is applied in excess, irrigation may create unwanted excess runoff from the site and possibly create conditions where vehicles could track mud onto public roads. Chemical applications should be used sparingly and only on mineral soils (not muck soils) because their misuse can create additional surface water pollution from runoff or contaminate ground water. Chemical applications might also present a health risk if excessive amounts are used.

### **Maintenance Considerations**

Because dust controls are dependent on specific site and weather conditions, inspection and maintenance are unique for each site. Generally, however, dust control measures involving application of either water or chemicals require more monitoring than structural or vegetative controls to remain effective. If structural controls are used, they should be inspected for deterioration on a regular basis to ensure that they are still achieving their intended purpose.

### **Effectiveness**

- Sprinkling/Irrigation. Not available.
- Vegetative Cover. Not available.
- Mulch. Can reduce wind erosion by up to 80 percent.
- Wind Breaks/Barriers. For each foot of vertical height, an 8-to 10-foot deposition zone develops on the leeward side of the barrier. The permeability of the barrier will change its effectiveness at capturing windborne sediment.
- Tillage. Roughening the soil can reduce soil losses by approximately 80 percent in some situations.
- Stone. The sizes of the stone can affect the amount of erosion to take place. In areas of high wind, small stones are not as effective as 20 cm stones.
- Spray-on Chemical Soil Treatments (palliatives). Effectiveness of polymer stabilization methods range from 70 percent to 90 percent, according to limited research.

For additional information, see "Dust Palliative Selection and Application Guide," 1999, USDA Forest Service, 9977-1207-SDTDC.

## APPENDIX I - Publication: “A Guide to Preserving Trees in Development Projects” by William Elmendorf of The Pennsylvania State University (1999)

Note: This publication is included, as written by the author, in this appendix for general information for the public. Some minor differences may exist in definitions used by the author and those in the glossary of this manual.

### Why Preserve Trees?

By their very nature, trees and green space provide benefits and add value to developments. The ability of trees to improve and maintain the quality of water, soil, and air and to remove pollutants from the air is well known. Trees also provide shade and help lower temperatures during hot weather. Trees enrich people’s lives and beautify landscapes. Preserving trees has positive effects on the image and attractiveness of developments and enhances developers’ reputations and profits.

Preserving trees in developments increases a project’s attractiveness, monetary value, and marketability by providing aesthetic and functional values. Lots where trees are preserved can be sold more quickly and at higher prices. Research has shown that mature trees increase the worth of a property up to 12 percent. Developers who understand these values realize that it is in their best interest to encourage the preservation of trees and green spaces.

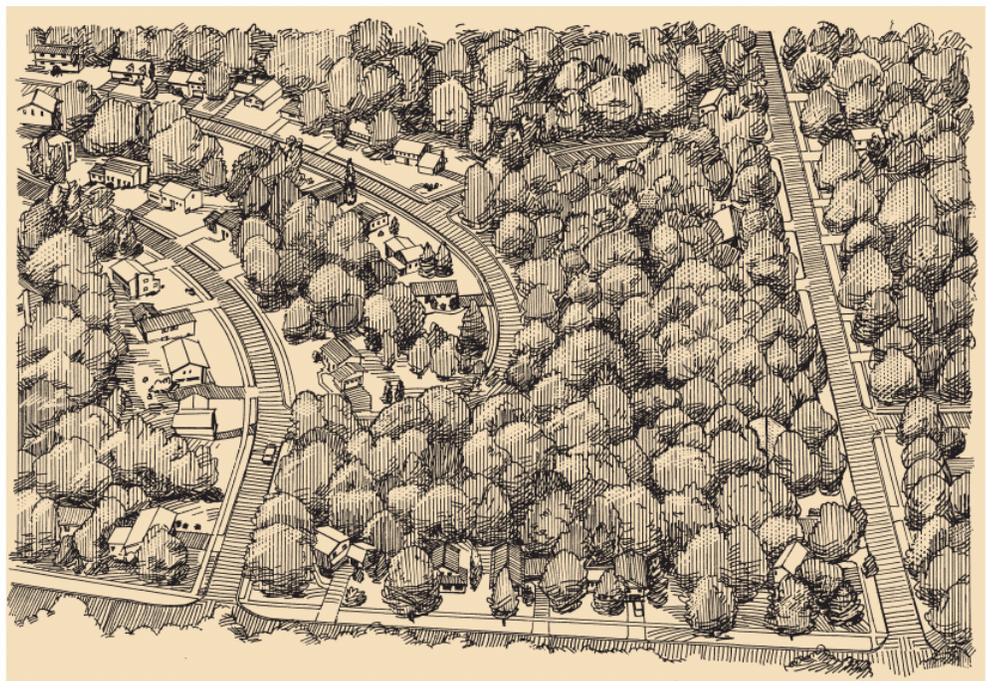
Developers can take advantage of different opportunities when considering the preservation of trees. Individual historic, landmark, and ornamental trees are all good choices for preservation, as are native trees in groves and woodlots. Opportunities differ from one development to another, but many of the recommendations for preserving trees remain the same.

Various people, such as arborists, engineers, architects, planners, and municipal officials, may become involved in preserving trees. Properly preserving trees in development takes time, good design, communication, and money. However, the results are worth the effort.

This publication provides helpful information to those who want to preserve trees, but know little about tree preservation techniques. Tree preservation starts with a basic understanding of the health of trees and the soils that support trees.



**Figure 1. Preserving historic, landmark, and suitable ornamental trees adds value to developments.**



**Figure 2. Preserving native trees in groves and woodlots provides economic and environmental value to developments.**



## Tree Health

Preserving trees is not very complicated if you understand how they function and what they need to grow. Trees are living organisms that respond to what is done to them and to the environment that they occupy. To stay healthy and vigorous, trees need air, water, and soil nutrients. They need a pollution-free and compaction-free soil that allows unhampered movement of water and air. Trees also need protection from insects, disease, and physical damage. Trees have roots, bark, a trunk, branches, and foliage, and they will thrive only if these organs remain healthy and undamaged.

Roots are essential to tree health. They support tremendous weight, store food, and take up water and nutrients from the soil. Tree roots need to be well anchored into a soil to hold the tree safely erect. Although the large, woody roots that support the weight of a tree and resist strong winds may reach deep into the soil, most roots that absorb water and nutrients can be found in the upper 12 to 18 inches of the soil. Roots are not confined to the area beneath a tree canopy—in fact, some roots can grow to more than three times the spread of the tree's branches.

Bark serves as a living barrier to insects, disease, and water loss, and as a transport system. On the inner side of the bark is the cambium, a single layer of cells that produce a new layer of xylem (wood) and phloem (bark) each year. Together, the xylem and phloem make up the circulatory system of the tree. Water and soil nutrients move upward in the wood, while manufactured food carbohydrate or sugar and growth substances (such as hormones) move downward and outward in the phloem.

A tree trunk provides height to the canopy of the tree, space for storing food materials, and support for the branches and leaves.

Tree limbs, branches, and twigs support leaves, where most of a tree's food is produced in a process called photosynthesis. The green chloroplast cells in a tree's leaves combine carbon dioxide, water, and radiant energy absorbed from the sun to produce oxygen and carbohydrates. Through the process of respiration, living cells in buds, leaves, roots, and other structures consume oxygen and convert the

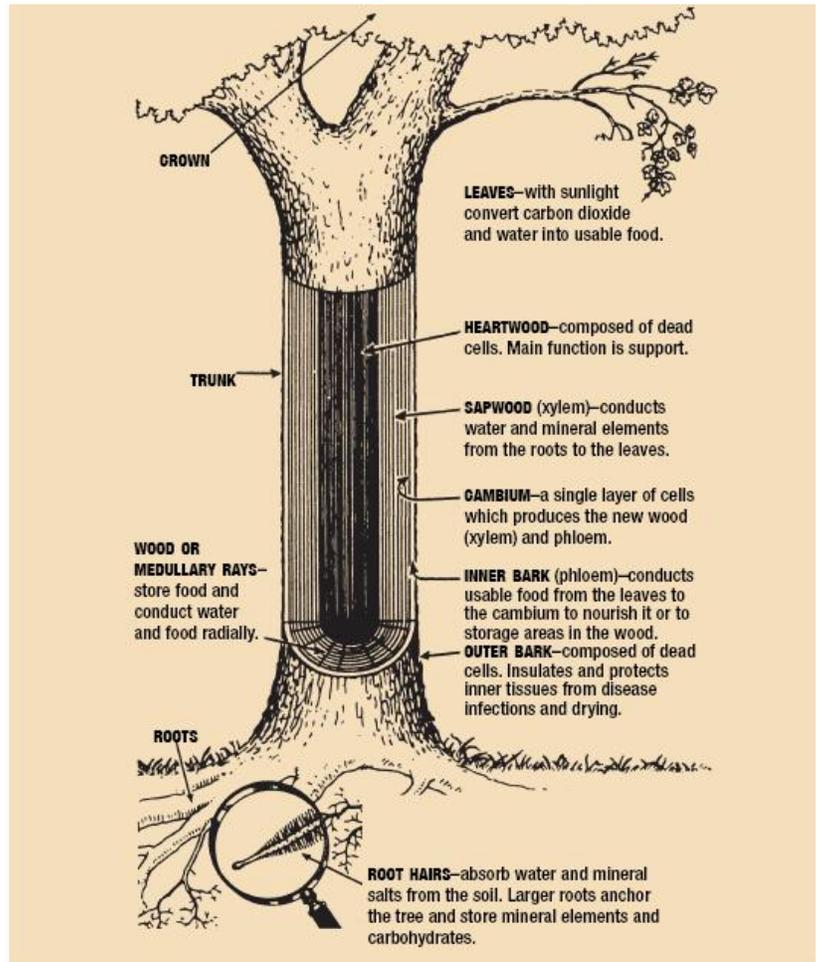


Figure 3. All of the important parts of a tree must be kept healthy for a tree to thrive.

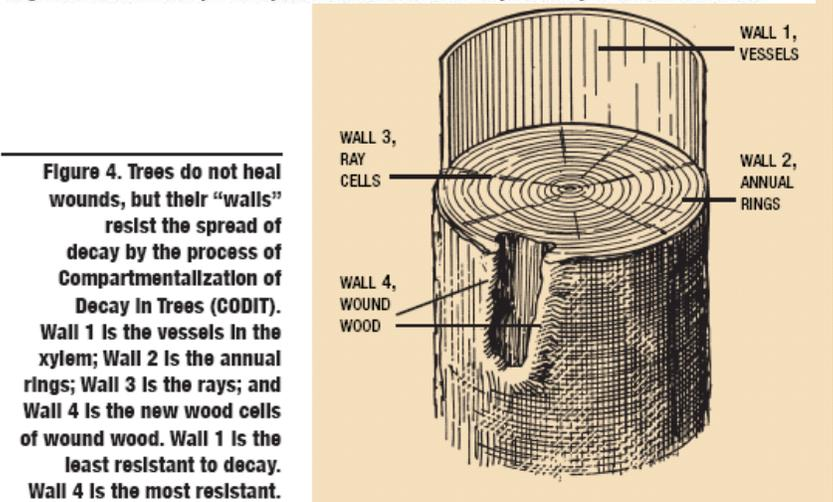


Figure 4. Trees do not heal wounds, but their "walls" resist the spread of decay by the process of Compartmentalization of Decay in Trees (CODIT). Wall 1 is the vessels in the xylem; Wall 2 is the annual rings; Wall 3 is the rays; and Wall 4 is the new wood cells of wound wood. Wall 1 is the least resistant to decay. Wall 4 is the most resistant.

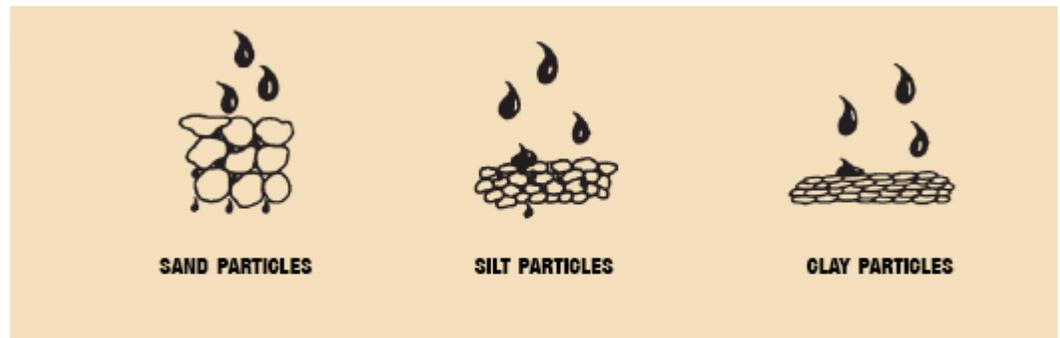
carbohydrates into other chemicals and energy the plant can use for growth, reproduction, and defense against decay. The production, or use, of energy in a tree is affected by a number of factors, including temperature, the amount of stored and available carbohydrates, the concentration of oxygen and carbon dioxide in the air, the amount of water in tree tissues, light levels, and whether the tree is injured. Tree injuries increase the rate of respiration and the use of stored carbohydrates. Repeated depletion of stored carbohydrates because of injury can threaten the tree's health at the time of injury and in the future.

Wounds that penetrate through the bark into the wood enable insects and fungi that cause decay or diseases to pass through the outer defenses of the tree. There is a misconception that trees are able to "heal their wounds." A tree does not heal, or fill, a wound. Instead, it defends against decay and discoloration by compartmentalizing the wound. Compartmentalization of decay in trees is a process that protects the unwounded part of a tree from decay through the development of physical and chemical boundaries that resist the spread of disease into surrounding wood.

If a tree is damaged by equipment or workers, it can be marred for life or killed. Wounds and pockets of decay do not fill, but are compartmentalized and covered by wound wood. As a result, pockets of decay never disappear, even if they are covered by new wood. Some trees decline slowly over a number of years because of construction injury, while others may die quickly. During construction, trees can be damaged by soil compaction, grade changes, root crushing and pruning, damage to the bark, improper pruning of branches, incorrect storage of construction materials, and dumping of construction wastes.

### Soil for Healthy Trees

Soil means different things to different people. To engineers and contractors, soil is the material that supports foundations, roads, and other structures. To horticulturists and foresters, soil is the medium in which plants grow. Soil can be a few inches deep



**Figure 5. The amount of sand, silt, and clay particles found within a soil make up a soil's texture. Structure is how these particles are grouped together.**

in some places and several feet in others. Soil supports tree establishment, growth, and reproduction. To remain healthy, trees need soil for water, nutrients, and structural support. Each soil type has unique characteristics of texture and structure. Soil texture is the relative proportion of the individual particles of sand, silt, and clay found within a soil. Sand particles are the largest and range from 0.05 to 2.0 mm in diameter. Silt particles are intermediate in size, ranging from 0.002 to 0.05 mm. Clay particles, the smallest soil particles, are less than 0.002 mm in diameter.

Construction activity will not change soil texture unless new soil or debris is brought to the site, but it can change soil structure.

There are many types of soils (see Figure 6). Soil structure is determined by the way in which individual particles of sand, silt, and clay are combined into aggregates over time. Structure is important because the fine spaces between soil particles hold water and air, which support plant growth, while the larger pore spaces between aggregates allow for the infiltration of rainfall and air.

Sandy soils consist of relatively large particles with large pore spaces between them and can have granular or crumb aggregates. Sandy soils are well drained and aerated, but have poor water- and nutrient-holding capacity. Clay soils consist of small particles with little pore space between them and

can have blocky aggregates. They have a high water- and nutrient-holding capacity, but may be poorly drained and aerated unless the soil has a well-developed structure.

Because of their high water- and nutrient-holding capacity, clay soils can be highly productive, but they are easily compacted. In addition to inorganic particles of sand, silt, and clay, decaying matter shed by plants (leaves, bark, branches, and decaying roots) forms a loose organic layer, or mulch, on the soil surface, which is gradually incorporated into the soil. This layer promotes the infiltration and retention of water, supports populations of beneficial soil organisms, reduces the risk of erosion, increases the development of soil structure, and provides a slow release of nutrients.

A good soil for plant growth is a mixture of clay, sand, and silt called a "loam." The ideal soil for tree growth is a loam that is well drained and aerated, contains 1 to 5 percent organic matter, has a covering of leaves and other organic material, and has an established population of living organisms such as fungi, bacteria, and earthworms.

Healthy trees need healthy roots and healthy roots need good soil structure. Care should be taken during construction to protect the structure of soil. Compacting soils harms trees by decreasing the ability of their roots to take up water, oxygen, and nutrients. Compacting soil with heavy equipment or stored materials destroys good structure of the soil by crushing and closing the pore spaces. Even foot traffic beneath trees in parks and around buildings can compact soils enough to be detrimental to tree health. Soil compaction slows or stops rainwater from infiltrating and also increases runoff, which reduces the amount of water available for plant growth. Compaction also interferes with the aeration of the soil, which lowers oxygen levels and raises carbon dioxide levels around tree roots. In areas where trees are to be preserved, soil should be protected from compaction by using the techniques discussed in later sections.

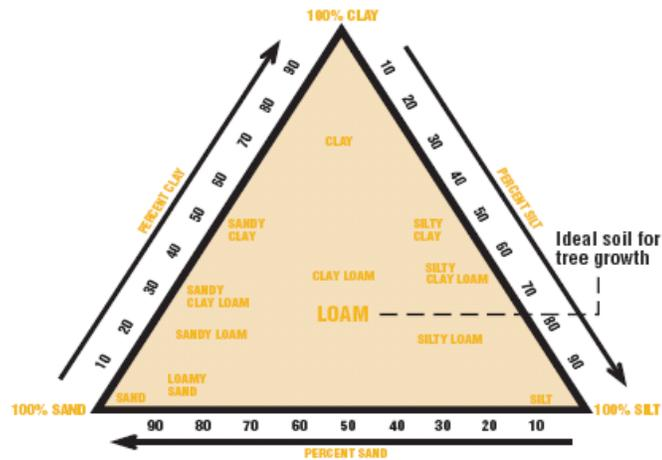


Figure 6. An ideal soil for tree growth is a mixture of sand, silt, clay, and organic matter, called loam.

## Preconstruction Activities

The goal of preserving trees in development projects is to protect adequate space for trees with the best health, structure, and appearance, while removing hazardous trees, lower quality trees, and others that are in the way of construction. Above all else, preserved trees need adequate space for root and canopy function and growth. The first preconstruction action is to decide how a tree inventory will be completed.

### Tree Inventory

A tree inventory provides information used to make decisions on which trees can be preserved and what measures are needed to protect them. It takes both common sense and professional advice to plan for and complete a tree inventory. Development parcels can have different types of trees arranged in different ways. They can range from large solitary trees to a complex array of species and sizes. The amount of time, effort, and money devoted to an inventory should match the characteristics of the tree resource, physical constraints imposed by the property, and the wishes of the developer. In some municipalities, tree preservation ordinances dictate the type and sizes of trees that should be inventoried. In others, the developer can decide freely how the inventory will be conducted.

There are two approaches to a tree inventory. The preferable way is to inventory trees before building pads, lot lines, and streets are engineered. The other is to collect information on trees after deciding upon lots and street locations.

For parcels with little variability in the size and species of trees, or no unique or special trees, a developer may choose to do a limited amount of inventory work after lot lines and streets have been surveyed. The developer may first want to stake the footprints, or outlines, of structures, streets, driveways, utilities, and grading. After staking these, trees that should be removed and trees that will be encroached upon by development can be identified. Hazardous trees on the property should also be identified and marked for removal. Developers can use the recommendations found in this guide, such as those for root and canopy pruning, to ensure the survival and long-term health of trees that remain, some of which may be affected by grading or other construction activities.

For development parcels with diverse, large, unique, or special trees, a developer should arrange a more thorough inventory. This type of inventory is completed before lot lines are placed, so that inventory information will be used by engineers and landscape architects in subdivision design. The inventory can be coordinated with initial survey work so information on tree condition, canopy size, and trunk location can be gathered at the same time as information on topographic and other physical features. A basic rule of this type of inventory is that information is collected on all trees in which there is an interest in preserving. If a parcel has many valuable trees and considerable development activity, all trees may be inventoried. In other situations, the developer can decide which categories of trees will be inventoried.

The first step in either approach is for the developer to conduct an initial walkthrough of the property with a qualified arborist, forester, or landscape architect. During the walk-through, decisions are made about which trees should be tagged and inventoried. A number of factors influence decisions about what kinds of trees should be tagged and inventoried:

*Species*—It is important to concentrate on the highest quality tree species. If a developer wants to remove all trees of an inferior species, they need only to be marked, but not inventoried.

*Size*—Although most people prefer larger trees, smaller trees such as dogwood, eastern redbud, and serviceberry should not be overlooked because they can be very valuable and add to the beauty of the property. The developer and consultant should decide the minimum diameter size of trees that will be inventoried for each species. Trees that are not inventoried are candidates for transplanting or removal.

*Forest Structure and Tree Location*—Groups or groves of trees on the edges of a property, trees in riparian areas, and trees clearly away from development activities need not be inventoried individually. Depending on the location of development, inventorying trees at the edge of groups and groves may be warranted.

*Hazardous Trees*—Hazardous trees should be identified and marked for removal, wherever they occur.

## **TREE PRESERVATION TAKES PLACE OVER TIME**

### **Preconstruction**

- Tree inventory
- Planning, design, negotiations
- Removals
- Staking of construction footprints under trees—required limb pruning
- Insect control or other care
- Fencing preserved trees

### **Construction**

- Communication and education
- Protection zones
- Required root pruning
- Maintenance of fencing
- Monitoring tree health
- Tree care

### **After Construction**

- Communication and education
- Protecting
- Tree care



*Site Characteristics*—Site characteristics such as fixed entrance points, steep slopes, and wetlands should be considered in deciding which trees to inventory.

Advice for Conducting a Tree Inventory

It is important to retain qualified people who are knowledgeable about the relationship between trees and construction and about species characteristics, tree health, and tree structure when conducting an inventory. In an inventory, a form is used to gather information on tree species, trunk diameter, height, crown size, condition, suitability for preservation, and maintenance needs. To allow identification of trees in the field, a pre-numbered aluminum tag available through forestry and horticultural suppliers is attached to each inventoried tree with an aluminum nail.

*Location and size*

To prevent untimely conflicts with buildings, streets, and equipment, the location and dimensions of trees should be established. Accurate information is important for preserving trees. Variations as small as several feet between actual and mapped tree locations can drastically affect the amount of root and canopy pruning needed to fit construction. For trees growing in large clusters or woodlots, developers only need information about the trees growing on the edge. For trees growing individually or in small clusters, more detailed information is required. For these trees, tree canopy dimensions should be measured at four

compass points, and the location and elevation of each tree trunk should be surveyed. This information is then placed on a grading or site plan. Accurate information on tree size and location allows developers, engineers, and landscape architects to compare the location of trees with the location of buildings, cuts, fills, retaining walls, streets, utilities, routes of heavy equipment, and other proposed construction activities.

TREE INVENTORY FORM								
Inspector: _____								
Date: _____								
Tree No.	Species	DBH	Tree Height	Distance to Dripline N W E S	Direction low or unusual branching N W E S	Tree Condition Good, Fair, Poor	Suitability for Preservation Good, Fair, Poor	Maintenance Recommendations and Comments

**Figure 7. A tree inventory form is used by a qualified individual to gather information for a tree report.**

*Condition*

Tree condition is a combination of tree health and tree structure and is a major factor in determining suitability for preservation and tree removal priorities. Tree health should not be confused with tree structure. A tree can be very healthy but have very poor structure because of decay. Similarly, a tree can be very unhealthy, but have a good structure because of a lack of decay. It is important to preserve only those trees that are healthy and structurally safe. Dead and dying trees and trees that are hazardous should be removed. Tree health is evaluated by observing crown density, foliage color and size, insect and disease problems, injuries, and amount of deadwood. Tree structure is a system of many interactive factors. To assess the structural safety of trees, evaluate the following:

- signs that the tree has dropped large branches in the past
- the condition of the root system, including past injury from root pruning

- trunk wounds, decay, cankers, or conks
- amount and size of deadwood or storm damage in the canopy
- abnormal branching habits, tree form, or weak crotches
- severity of leans and other structural irregularities

Evaluating tree structure and hazard is complicated, so a qualified arborist should be consulted, especially about older and larger trees that will be close to people, buildings, play areas, sidewalks, and cars. Costly measures have been taken to preserve trees in poor condition, but which have great historical or aesthetic value.

*Suitability for preservation*

Species, condition, size, age and other factors are used by a qualified inspector to evaluate the suitability of a tree for preservation. In general, certain tree species are more desirable for preservation than others. For example, because white oaks and sycamores are structurally stronger and live longer than silver maples or cottonwoods, they should be given a higher suitability for preservation. Silver maples have a lower preservation value because of their potential to develop structural weakness and to therefore be hazards in developed areas, especially if their roots are damaged during construction. Species with undesirable characteristics such as narrow branch angles, weak wood, susceptibility to severe pest problems, or short life expectancy should be given a lower suitability for preservation than trees of more desirable species.

**GUIDE FOR ASSIGNING CONDITION CLASS OF TREES**  
Condition = health and structure

CONDITION	DEADWOOD	FOLIAGE	TRUNK
Good	Dieback limited to less than 10 percent of smaller branches.	Normal for species in size and color. Crown density is normal.	Less than 20 percent of trunk has any decay. No decay fungus mushrooms present.
Fair	Dieback includes 10–20 percent of smaller branches and 1 to 2 large, dead branches.	Reduced in size. Lighter in color than normal. Crown density is sparse.	20–33 percent of trunk has decay. Decay fungus mushrooms may be present.
Poor	Dieback includes more than 30 percent of small branches, 3 or more major branches.	Greatly reduced in size and yellow. Crown density is very sparse.	More than 33 percent of trunk has decay or is hollow. Decay fungus mushrooms may be present. More than 33 percent of roots removed or decayed.

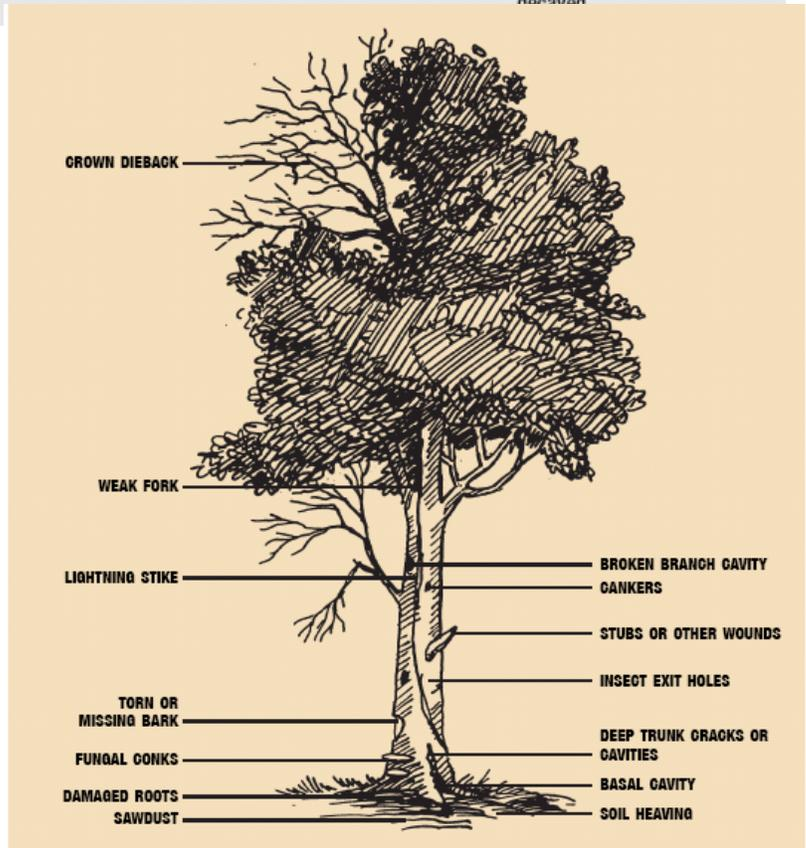


Figure 8. Undesirable tree characteristics to look for when evaluating tree condition and suitability for preservation.

Condition, size, and age also are important factors in determining a tree’s suitability for preservation. For example, a large white oak with decay, many lost branches, and no historical value would have a poor suitability for preservation, while a large white oak in good condition would have a good or excellent suitability for preservation.

### Identify trees in need of care

In the inventory, recommended actions are made to improve the health and structure of worthy trees, especially landmark and other prominent trees. These maintenance recommendations include needed irrigation, fertilizing, pest and disease management, cabling or bracing, and especially pruning.

The information gathered in a tree inventory is summarized in a tree report, and tree canopy dimensions and trunk locations are placed on site or grading plans to develop a tree preservation plan. The tree report and tree preservation plan allow information on tree health and structure, as well as on tree size and location, to be considered when designing a development.

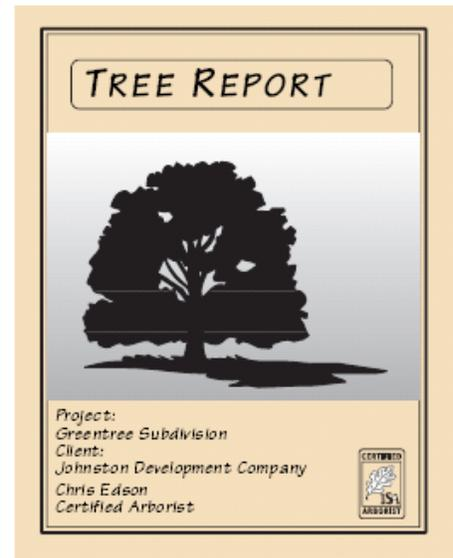
## Using Tree Inventory Information

### Tree Report

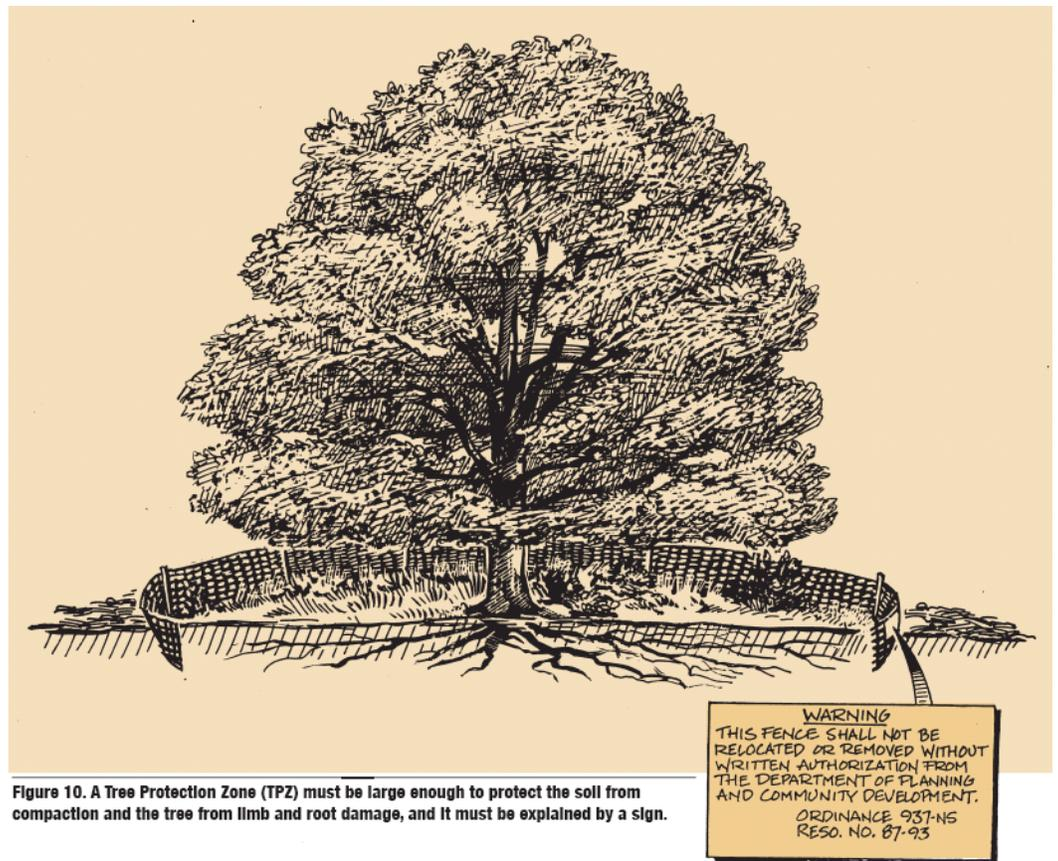
The tree report summarizes inventory data on hazardous trees that should be removed, tree maintenance needs, tree condition, tree suitability for preservation, and which trees should be offered the most protection. The report should identify trees of exceptionally high or low value or interest. In addition, elevation and plan drawings of proposed tree encroachments can be provided. A qualified horticulturist, forester, arborist, or landscape architect should be employed to complete the tree report. The report is provided along with the tree protection plan to everyone who will make decisions about development design and tree preservation.

### Tree Protection Zone

Injuries to a tree or group of trees can be minimized by providing a tree protection zone (TPZ), a fenced area around a tree that will not be disturbed by construction work. Information from the tree report is used to determine TPZ locations. In a TPZ, the soil is protected from compaction, critical roots are not damaged by pruning, trenching, or excessive grade changes, and trunk and branches are not damaged by equipment or workers. A TPZ will ensure that a tree is protected during construction, has enough space for root and branch growth, and will receive adequate supplies of soil nutrients, air, and water.



**Figure 9. A tree report provides information on tree species, location, condition, and suitability for preservation. This information can be used to determine if trees should be removed, encroached upon, or retained in a development.**



**Figure 10. A Tree Protection Zone (TPZ) must be large enough to protect the soil from compaction and the tree from limb and root damage, and it must be explained by a sign.**

When determining the size of a TPZ, the needs of the tree should be considered along with the needs of the contractor on the site. Ideas vary about the correct size for a TPZ, and generally it should be established at or outside the dripline of a tree when feasible. However, space can be limited on construction sites where buildings, infrastructure, and trees should all be accommodated. Also, trees have a variety of canopy shapes—some broad, and others upright or narrow. Using the dripline as a guide for the size of a TPZ could lead to the establishment of protection areas that are either too large or too small, depending on the growth habit of the particular tree. Using the dripline as a rule for a TPZ has been recommended for broad-canopied trees, such as open-grown oaks.

It is commonly thought that trees can withstand the removal of 30 to 50 percent of their root system, but structural stability may be compromised after the removal of more than one-third. Because it is difficult to estimate the full extent of a tree's root system, it is difficult to know when a certain percentage of roots has been affected. Providing an adequate TPZ helps preserve needed tree roots. A *minimum* TPZ for a tree can be determined by using the following rule: Measure the diameter (in inches) of a tree trunk at a point 4.5 feet aboveground, known as the diameter at breast height (DBH). Define a circle around the tree with a diameter in feet equal to the number of inches of the trunk's DBH. For example, a red oak with a diameter of 10 inches would have TPZ 10 feet in diameter. This rule defines the minimum distance to keep construction activity and storage of equipment and materials away from a tree. The more undisturbed space that can be provided around a tree, the better the tree's chances of survival and subsequent growth.

Another TPZ method is described by Jim Clark and Nelda Matheny in their book *Trees in Development* (International Society of Arboriculture, Savoy, IL). In this method, the TPZ depends on the tolerance of a tree species to construction impact, as well as the tree's age and vigor (see Tables 1 and 2). Young, vigorous trees of a species with good tolerance to construction impact can have smaller TPZs. For especially valuable, large, old, historic, or landmark trees, the TPZ should extend at least to the dripline, preferably beyond, and should be established by an experienced arborist or horticulturist.

**TABLE 1. Guidelines for Tree Protection Zones. Distances should be increased for trees of poor vigor and to protect young and other trees with low branching from severe pruning of limbs. This table is adapted from a table provided courtesy of the International Society of Arboriculture, Savoy, IL.**

SPECIES TOLERANCE TO IMPACTS	TREE AGE	DISTANCE FROM TRUNK* (feet per inch of trunk diameter)
<b>tolerant</b>	young <1/4 life expectancy	0.5'
	middle aged 1/4-3/4 life expectancy	0.75'
	mature >3/4 life expectancy	1.0'
<b>intermediate</b>	young	0.75'
	middle aged	1.0'
	mature	1.25'
<b>sensitive</b>	young	1.0'
	middle aged	1.25'
	mature	1.5'

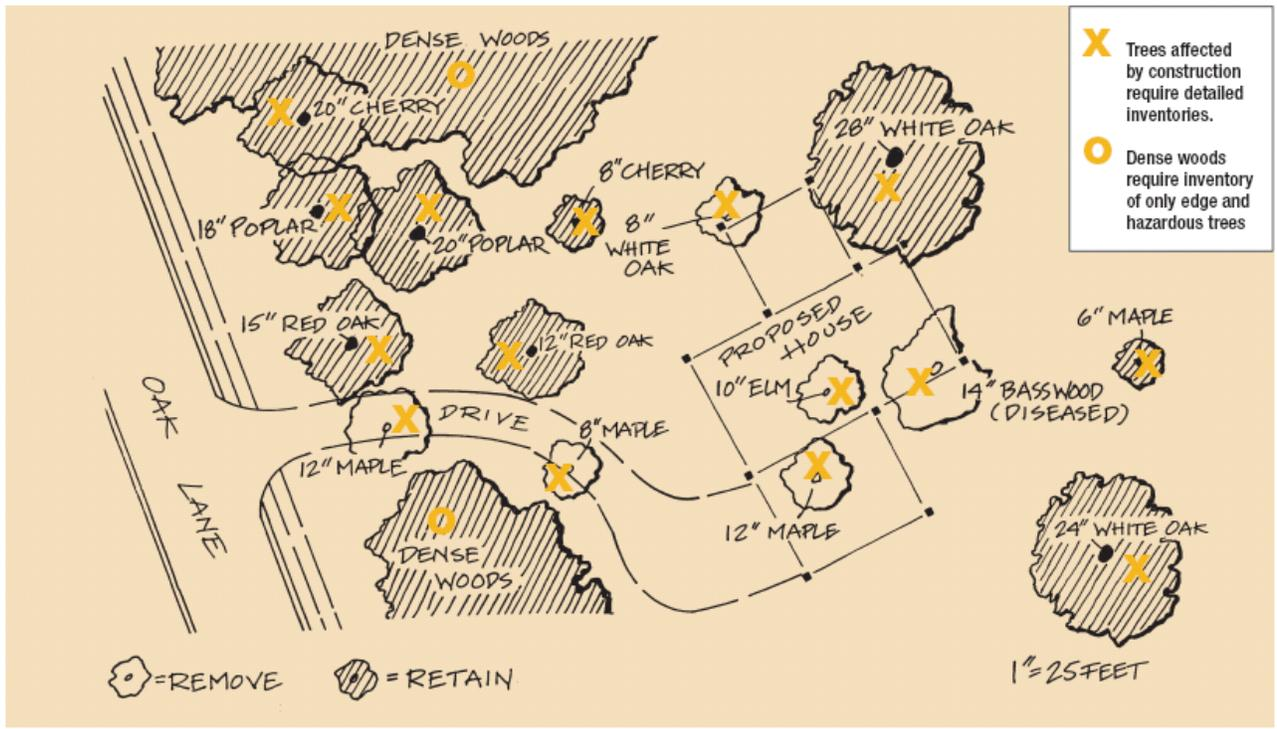
\*These distances are based on a tree's tolerance to root pruning and soil disturbance and may not be adequate to protect branches of young trees or other trees with low branching. Because severe pruning would destroy the form of such trees, fencing at the dripline or beyond should be considered.

**TABLE 2. Size and Tolerance of Tree Species to Construction Impacts. This table represents opinions of the authors and information from three publications: Tree Characteristics, Protecting Trees from Construction Damage, Minnesota Extension Service, University of Minnesota; The Response of Ohio's Native and Naturalized Trees to Construction Activity, T. Davis Sydnor, School of Natural Resources, The Ohio State University; and Relative Tolerance of Tree Species to Construction Damage, Klm D. Coder, The University of Georgia Cooperative Extension Service, Forest Resources Unit.**

Tolerance to construction impact can vary greatly according to site characteristics such as soil depth, individual tree characteristics such as rooting habit, prevailing weather conditions such as drought, and the degree of construction impact.

SPECIES	ROOT SEVERANCE	SOIL COMPACTION AND FLOODING	MATURE CROWN SPREAD (FEET)	HAZARD POTENTIAL RATING	COMMENTS
ailanthus	tolerant	tolerant	20-40	low	
arborvite	tolerant	tolerant	5-10	low	
black ash	tolerant	tolerant	30-60	medium	
green ash	tolerant	tolerant	30-50	medium	
white ash	tolerant	intermediate	40-70	medium	
bigtooth aspen	tolerant	sensitive	20-35	medium	sensitive to increased light and heat
quaking aspen	tolerant	sensitive	20-35	medium	
American Basswood	sensitive	sensitive	50-75	medium	sensitive to fill
American beech	sensitive	sensitive	30-50	medium	
blue beech	sensitive	sensitive	15-20	low	
gray birch	tolerant	tolerant	30-50	low	
paper birch	intermediate	sensitive	30-50	medium	
river birch	tolerant	tolerant	30-50	low	
yellow birch	intermediate	sensitive	25-50	medium	
blackgum	tolerant	tolerant	40-60	low	
boxelder	tolerant	tolerant	35-50	high	
Ohio buckeye	sensitive	sensitive	30-40	medium	
butternut	sensitive	sensitive	50-60	medium	
catalpa	intermediate	tolerant	30-50	medium	
Eastern red cedar	tolerant	sensitive	10-20	low	
Northern white cedar	tolerant	tolerant	10-20	low	
black cherry	intermediate	sensitive	40-50	low	
Kentucky coffeetree	intermediate	intermediate	40-50	low	
Eastern cottonwood	tolerant	tolerant	80-100	high	
crabapple	tolerant	tolerant	20-30	low	
dogwood	intermediate	intermediate	15-20	low	sensitive to increased light and heat
American elm	tolerant	intermediate	70-150	medium	
slippery elm	tolerant	intermediate	40-60	medium	
balsam fir	tolerant	tolerant	20-35	medium	
white fir	tolerant	sensitive	10-20	medium	
ginkgo	tolerant	tolerant	40-80	low	
hackberry	tolerant	intermediate	50	low	
hawthorn	tolerant	tolerant	20-30	low	
Eastern hemlock	sensitive	sensitive	25-35	medium	sensitive to fill
butternut hickory	intermediate	sensitive	30-40	medium	
American holly	tolerant	tolerant	18-40	low	
honeylocust	tolerant	tolerant	50-75	medium	
ironwood	sensitive	sensitive	20-30	low	
larch	tolerant	tolerant	15-25	medium	
black locust	tolerant	tolerant	20-50	high	
red maple	tolerant	tolerant	40-60	medium	sensitive to wounding
silver maple	tolerant	tolerant	50-75	high	
sugar maple	tolerant	sensitive	60-80	medium	sensitive to fill
bicolor oak	tolerant	tolerant	40-50	low	
black oak	intermediate	intermediate	50-70	low	
bur oak	tolerant	tolerant	40-80	low	
pin oak	sensitive	tolerant	30-50	low	
red oak	tolerant	sensitive	40-50	low	
shumard oak	tolerant	tolerant	40-60	low	
white oak	sensitive	sensitive	50-90	low	
willow oak	intermediate	intermediate	30-40	low	
osage orange	tolerant	tolerant	20-40	low	
jack pine	tolerant	sensitive	20-30	medium	
red pine	tolerant	sensitive	20-40	medium	sensitive to increased light and heat
Scotch pine	tolerant	sensitive	30-50	medium	sensitive to poor drainage
white pine	tolerant	sensitive	40-60	medium	sensitive to drainage changes
redbud	intermediate	intermediate	25-35	low	sensitive to increased light and heat
serviceberry	intermediate	intermediate	15-20	low	
sweetgum	tolerant	tolerant	40-65	low	
black spruce	tolerant	tolerant	15-30	medium	
Colorado spruce	intermediate	tolerant	20-30	medium	vulnerable to windthrow
Norway spruce	tolerant	tolerant	20-30	medium	vulnerable to windthrow
white spruce	tolerant	tolerant	20-30	medium	
sycamore	tolerant	tolerant	75-100	low	
tulip tree	sensitive	intermediate	35-50	high	
black walnut	sensitive	intermediate	50-70	medium	
black willow	tolerant	tolerant	20-40	high	
weeping willow	intermediate	intermediate	30-40	high	

\*Hazard Potential Rating refers to the relative potential for a tree to become hazardous due to its large size and likelihood of breakage or decay. For a tree to be considered hazardous, a likely "target" (e.g., a person, a house, or car) must be present. A high rating does not imply that an individual tree is likely to fail.

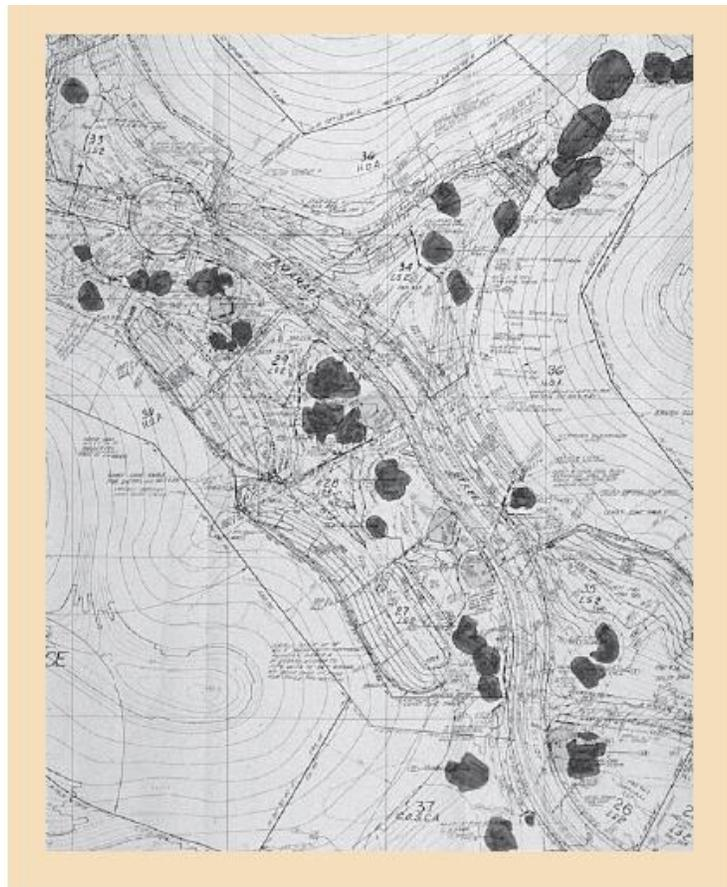


**Figure 11.** A simple tree preservation plan shows the location of house, driveway, and trees to be removed, encroached upon, and retained.

### Tree Preservation Plan

Information on tree preservation zones and the location, size, and condition of trees from the tree report is combined with information on a grading or site plan to prepare a tree preservation plan. The tree preservation plan shows the location of development footprints, including buildings, utilities, and streets, and how trees and tree preservation zones relate to them. The tree preservation plan helps developers make decisions about which worthy trees can be preserved, which should be removed, which can be transplanted, and how trees may be encroached upon. This plan also helps developers determine how footprints, streets, and other factors can be altered to facilitate tree preservation.

A tree preservation plan identifies places where limited space needs to be carefully managed when developers are trying to accommodate both trees and construction. This type of plan leads to changes during the early stages of development that will preserve important trees and help developers avoid costly mistakes and delays. The best plans provide adequate tree protection zones that separate buildings, infrastructure, and construction activities from worthy trees. The following guidelines can help you develop a tree preservation plan.



**Figure 12.** More complex tree preservation plans use a grading plan to show the relationship of grading and construction to trees.

Use accurate information.

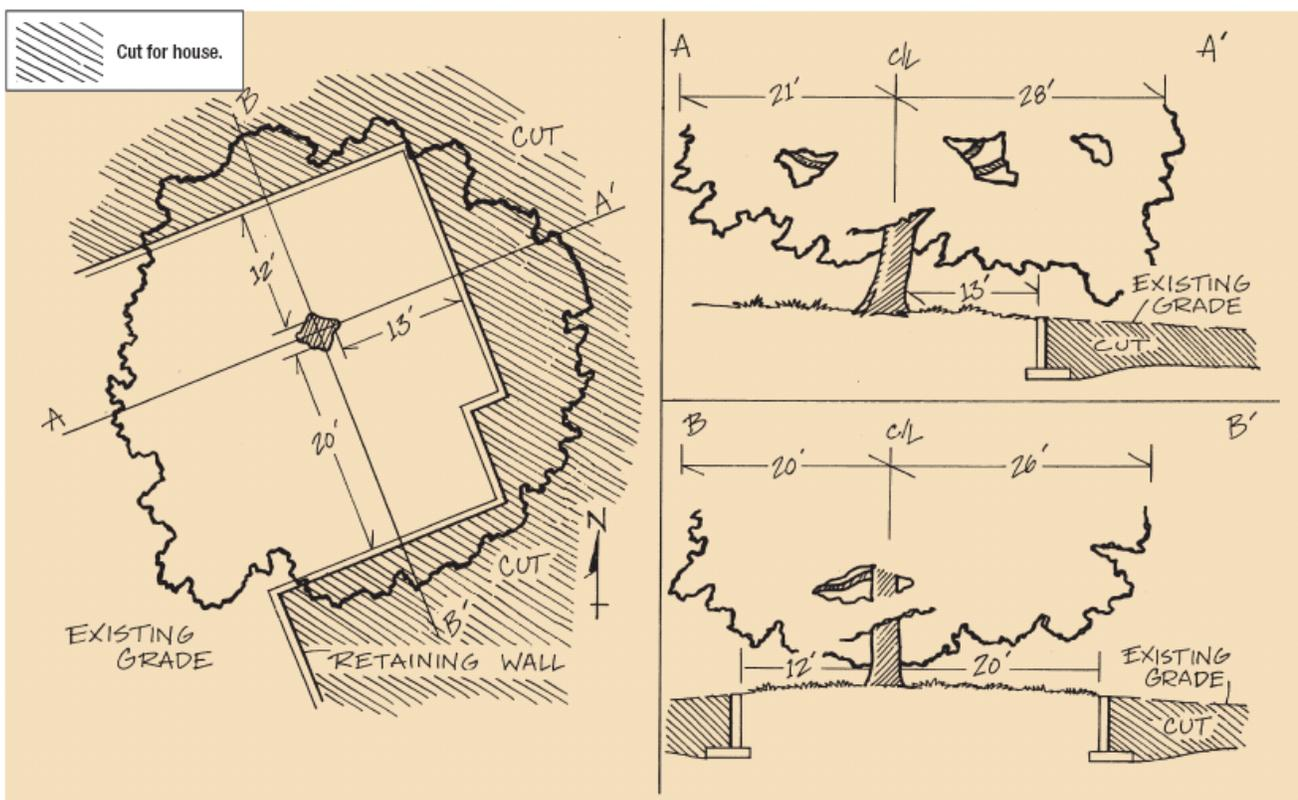
The plan should accurately show the spatial relationships between trees and development. A few feet can determine whether or not a tree can be preserved. Errors in either tree or construction location make a tremendous difference in the size of tree preservation zones and the amount of root and canopy pruning required. Problems caused during the construction phase because of inaccurate information about tree location and condition can be expensive in terms of tree health, time, and work interference.

Place utility paths on plans.

Trenches and overhead wires for utilities should be identified on tree preservation plans.

Identify affected trees.

Clearly mark on the grading or site plan any trees that are to be preserved, removed, or pruned, or that might be encroached upon by buildings, roads, parking lots, or utilities.



**Figure 13. Information from a tree report and tree preservation plan can be used to prepare plan and elevation drawings of proposed construction impacts to trees. These drawings help developers visualize the impacts soil compaction and required limb and root pruning will have on trees.**

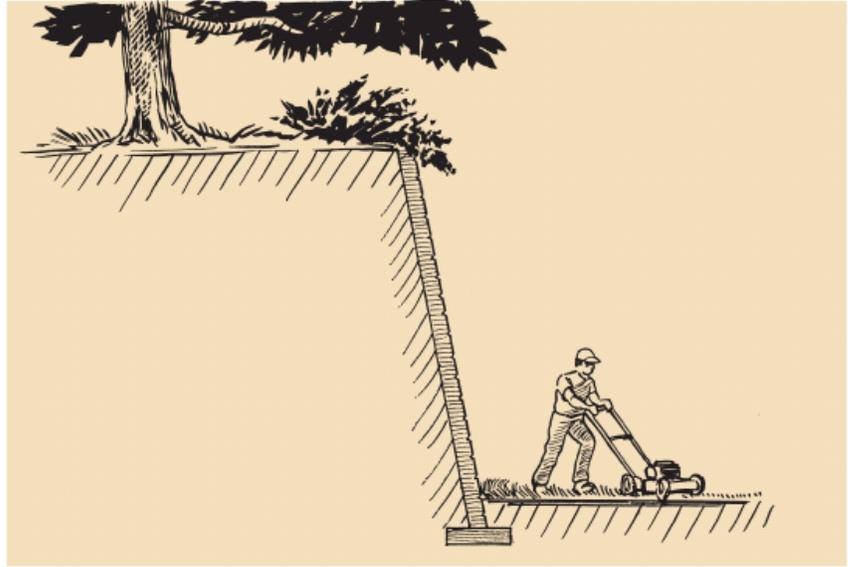
Consider alternative plans to minimize construction impacts on suitable trees.

Attempts should be made on grading and site plans to eliminate or minimize construction impacts on worthy trees by removing less worthy trees and moving or altering grading, buildings, utilities, and other infrastructure elements. For example, a medium-quality tree might be marked for removal to prevent encroachment on and pruning of a higher-quality tree. Less suitable trees (in terms of species, condition, and age) should be marked for removal to provide space for more suitable trees. All dead or dying trees and hazardous trees should be removed. Only trees that are in good, safe condition should be saved in parks or near buildings, sidewalks, and streets. Nuisance trees such as mulberry (messy

fruit) and osage orange dangerous fruit) can be preserved if they are a safe distance away from buildings, walkways, and parking areas.

Consider alternative construction techniques.

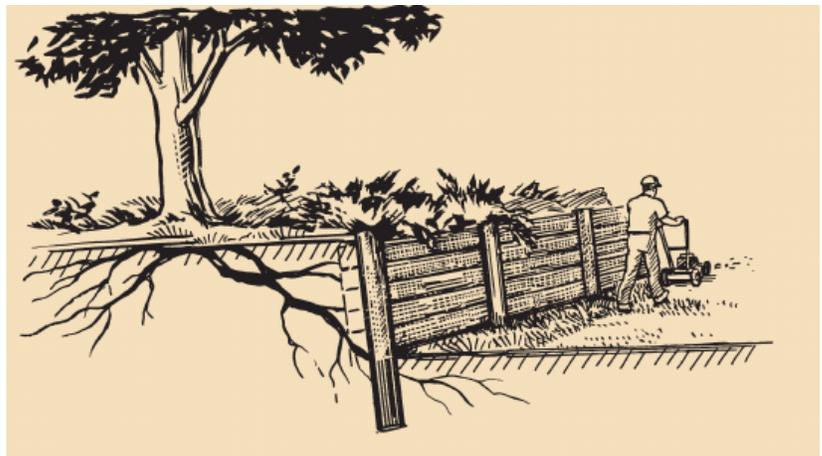
A variety of construction elements and techniques can be used to help preserve trees while providing space for development. For example, crib and retaining walls can be used to limit the length of manufactured slopes and keep soil cuts and fills out of a tree protection zone. Engineered pier or grade beam footings, which reduce pruning damage to tree roots, can be used when working close to tree trunks. Self-supporting concrete or asphalt sections can be engineered to reduce soil compaction and root damage when sidewalks, parking lots, streets, and driveways are placed under or close to trees.



**Figure 14. Crib walls can be used to limit the length of manufactured slopes, providing more room for trees and development.**

Consider energy needs of buildings.

Strategic tree and building placement can reduce annual energy use for heating and cooling by as much as 10 percent. To help cool buildings in the warm months, trees can be planted or preserved on the west and east sides. To help retain heat in the cold months, construct windbreaks to the northwest of buildings and remove trees to the south of buildings up to a distance equal to the height of a tree, unless they are particularly valuable.



Consider replacing or moving trees.

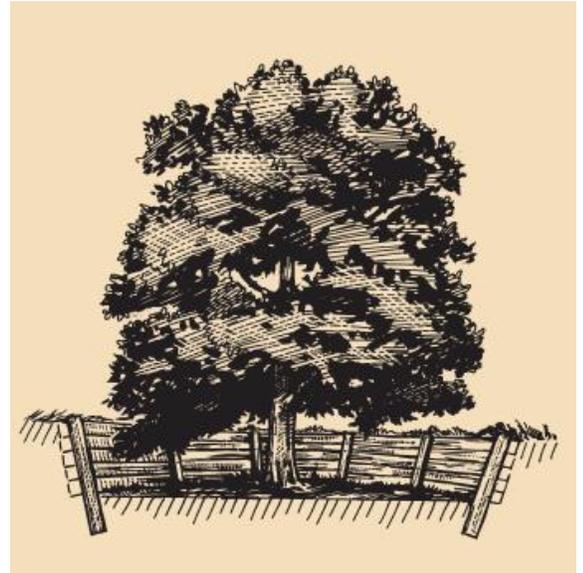
Smaller trees sometimes can be replaced for less than it would cost to preserve them. Nursery plants can be placed in just the right locations and are often of equal or greater value than existing smaller trees. Usually it is more beneficial and effective to save larger trees, because larger trees can provide greater functional and aesthetic benefits and have surprisingly high monetary values in landscapes. The International Society of Arboriculture's *The Guide for Plant Appraisal* (International Society of Arboriculture, Savoy, IL) can be used to appraise the value of trees in developments. In Pennsylvania, a tree with a 25-inch trunk diameter could be worth as much as \$10,000.

Existing trees could be transplanted to other locations on the site. Trees that are 4 inches DBH or less could possibly be moved with backhoes or other equipment already owned by most contractors. However, such an operation requires a knowledgeable and experienced person to be successful. Tree spades or other equipment for moving trees up to 10 inches DBH are available in many communities. Larger trees can be moved with cranes and other special equipment, but the relocation costs may exceed the costs associated with saving them at their existing locations.





**Figure 15. Attractive retaining walls can be used to limit the size of fill and cut slopes, increasing the size of a tree's protection zone.**



The transplanting process requires cutting many of a tree's roots, which puts the tree under severe stress. Even with special care, such as staking, irrigation, and fertilization, it often takes several years for a larger tree that has been transplanted to regenerate enough roots to continue growing at a normal rate. All of these factors and costs should be considered when deciding whether it is better to preserve a tree at its existing location, replace it with nursery stock, or relocate it on a construction site.

Consider cluster development and other alternative subdivision designs.

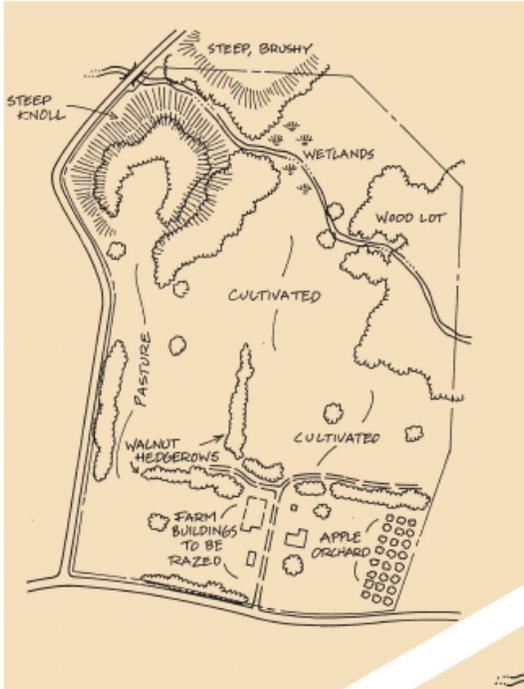
Developers of larger projects may wish to consider setting aside groves of trees to provide recreation, wildlife habitat, and other environmental benefits. Because of these benefits, it is often desirable to incorporate groves of trees into a development's landscape.

Trees growing in groups have adapted to each other and to their light, wind, and soil conditions. These conditions change when exterior or interior trees in a group are removed. The remaining trees may be subject to windthrow, sunscald, altered soil conditions, and altered water availability.

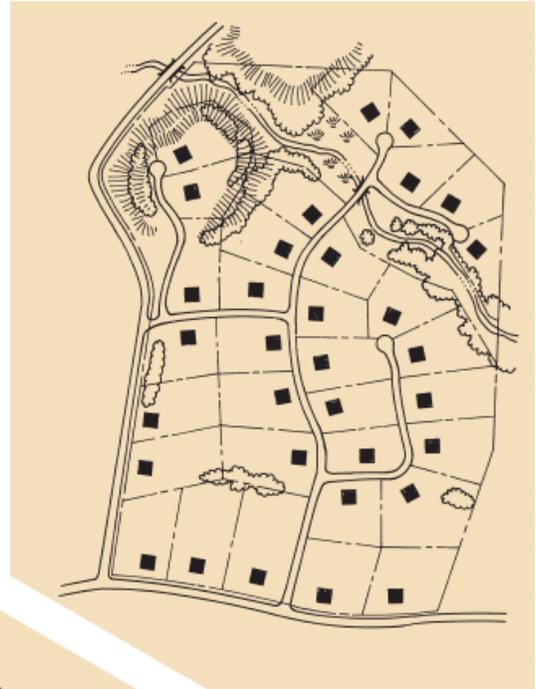
Cluster development can be used to preserve trees and other natural resources in developments. However, it may conflict with local zoning and subdivision ordinances or with the traditional philosophies of builders. The following practices can help create space for trees and other natural resources:

- Complete a natural resource inventory that identifies important views, riparian areas, paths, and other resources.
- Design grading and site plans to meet specific site characteristics.
- Keep front yard setbacks to a minimum.
- Keep areas of turf and grass to a minimum.
- Use step-down or other types of foundations that reduce grading.
- Keep the width of roads to a minimum.
- Delete or rearrange lots to provide more space for trees.

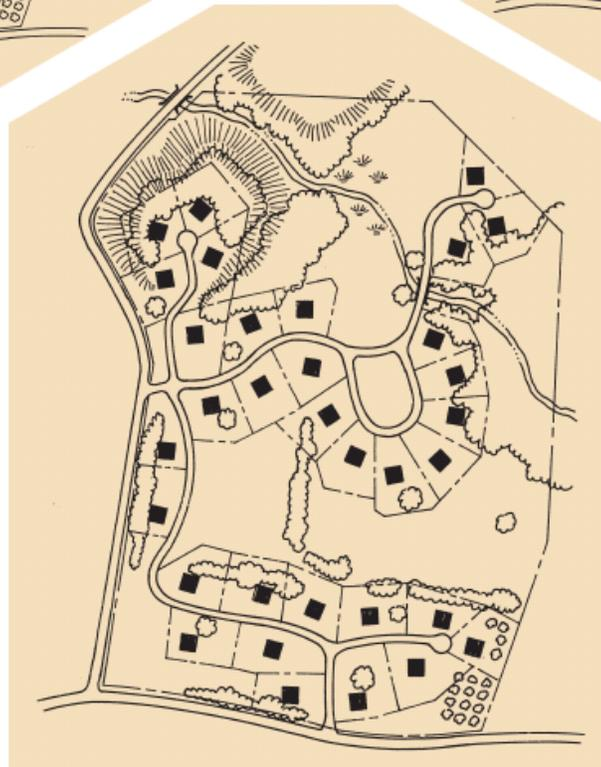
- Design developments in a clustered format.
- Work with municipal officials to explain the advantages of creative subdivision design.



**Figure 16. A natural resource inventory identifies all important natural characteristics of a site.**



**Figure 17. Traditional subdivision design provides for the maximum number of minimum-sized lots and does not consider preserving woodlots or other natural features.**



**Figure 18. Cluster development can be used to protect development densities while preserving woodlots, meadows, and riparian areas.**

### Construction Activities

All of the work put into the tree report and the tree preservation plan can be lost through carelessness. It only takes a moment for a piece of heavy equipment or a person with a chain saw to injure or kill a tree that was selected for preservation. Other construction activities, such as the cleaning of cement trucks and paint equipment, can seriously injure or kill a tree. Developers, contractors, and home builders should take every precaution to ensure that trees designated for preservation are not injured during construction. This requires that trees be protected by fenced tree protection zones and that workers be properly instructed and monitored.

Protecting Trees During Construction

Contractors, equipment operators, and workers should be informed of the importance of protecting trees that have been selected for preservation. This message can be reinforced by establishing penalties that should be paid if trees are injured or killed during construction. Penalties should be large enough to emphasize that large trees can be worth thousands of dollars and even small trees can cost hundreds of dollars to replace. The value of injured or killed trees can be appraised by qualified arborists using the International Society of Arboriculture's *Guide for Plant Appraisal*. In addition, lot owners or home builders can have tree preservation terms written into their contracts with developers and contractors.

- .....
- TYPES OF CONSTRUCTION INJURY**
- Soil compaction or pollution
  - Root removal and wounds
  - Disruption of mycorrhizae and other beneficial soil organisms
  - Trunk and butt wounds
  - Branch wounds
  - Leaf injury
  - Unwarranted tree removal

The following recommendations should be implemented to help protect trees during the construction phase.

- .....
- SYMPTOMS OF CONSTRUCTION INJURY (SOIL DESTRUCTION)**
- Reduced canopy density
  - Reduced leaf size
  - Lighter green color of the foliage
  - Branch/canopy dieback
  - Development of early fall color or leaf drop
  - Suckering
  - Root rot
  - Long-term decline

*Using the tree report and tree preservation plan to evaluate trees in the field.*

Proposed tree encroachments can be staked in the field so that needed root and canopy pruning and tree removals can be completed before construction begins. Staking curblines, foundations, and other elements also allows for additional evaluation of tree protection techniques, such as retaining walls, before construction begins. Lay out temporary roadways and storage areas.



**Figure 19.** Without a tree protection zone, trees and soils can be severely damaged by construction activities. Damage can lead to either fast decline in health or a very slow decline and eventual death.

*Hurricane or other protective fencing should be placed around a TPZ to physically protect trees.*

Fencing provides a protective barrier and also reminds workers that protecting trees is important. Contractors and workers often want to change or move fencing to make adjustments for construction activities were not adequately planned and designed. Fencing should be checked periodically and people involved in a project informed that moving a fence is acceptable.

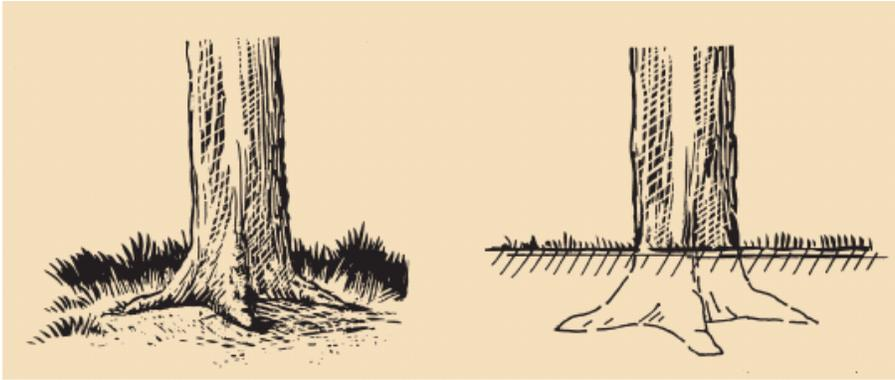
*raise or lower the natural soil level a TPZ.*

Raising the grade within a TPZ by adding or "filling" soil reduces water infiltration and air exchange in the soil around the roots. Lowering the grade "cutting" soil removes both soil and roots, and also damages the roots that remain. Filling or cutting soil within a can severely injure or kill a tree.

that  
not  
Do not  
within  
or  
tree  
TPZ

*Consider impacts away from important trees.*

Construction activities well outside the tree protection zone also can have detrimental effects on a tree's health. For example, cuts and fills can affect natural aquifers and drainage patterns. Large manufactured slopes created by cuts uphill from trees can remove their water source, or increase erosion. Compacted fills and retaining walls on the downhill side of trees can act like dams, causing water to accumulate. Positive drainage should be provided for preserved trees where needed. Effects of grading on important trees should be evaluated.



**Figure 20. Do not raise the natural soil level within a TPZ. Trees that have been buried in fill can be identified by a lack of root flare.**

*Do not store materials or operate equipment near or under trees.*

Transporting, handling, and storing building materials and supplies near and under trees can compact the soil, which kills and injures tree roots. In addition to injuring tree roots, construction equipment can break limbs or wound bark.

Equipment should not be operated in the TPZ and nothing should be stored in it,

including fuel, chemicals, soil, and construction materials.

*Do not pollute the soil within a TPZ.*

Arrange for proper disposal of construction waste. Soils may be polluted by the on-site disposal of construction residues, petroleum products, or other chemicals. Lime-based products such as cement and plaster can dramatically raise the alkaline level of the soil. Many trees, such as pin oak, red maple, and sweetgum, cannot tolerate high pH or alkaline soils. Burying rocks and other debris near trees can damage and inhibit their root growth. The pollution of soils should be prevented if they are to support root growth.

*Designate specific sites for equipment cleaning or disposal of construction debris.*

Do not bury construction debris to avoid the cost of hauling and disposal. Only

sites that are well away from tree preservation or planting areas should be designated for equipment cleaning and disposal of debris.

*Use construction designs that minimize soil compaction for streets, parking lots, driveways, and patios.* Streets and parking lots cannot support their own weight, so soil compaction is a requirement for standard asphalt or concrete construction. Self-supporting or permeable asphalt or concrete sections



**Figure 21. Cutting or lowering the soil level near a tree severely damages tree roots, leading to a decline in health and even to death.**

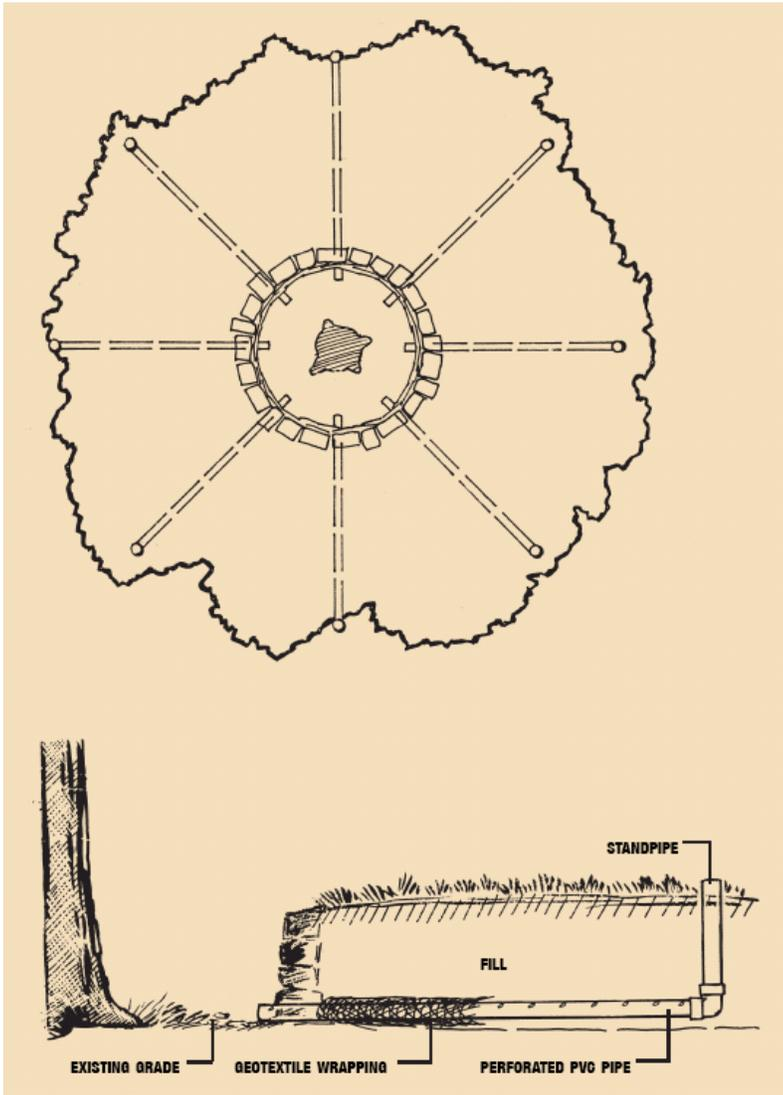


Figure 22. Aeration systems should be designed by professionals and used only when absolutely necessary. The effectiveness of aeration systems is debatable. Some of the disadvantages of 4-inch PVC pipe may be avoided by using a flexible drainage system.

for streets and parking lots can be engineered and constructed around trees of high value.

*Use aeration and other special preservation systems only when absolutely necessary.*

If nonstructural fill is to be placed and lightly compacted within a tree protection zone for a parking lot or other hard surface, an aeration system can be used to assist in the infiltration of water and air. These systems should be designed and installed by professionals.

Self-supporting and permeable surfaces are one example of an aeration system. A properly installed aeration system can also consist of a flexible drainage system. In the past, aeration design has specified using 4-inch perforated PVC pipe.

However, roots can grow into, and clog, the perforations. Wrapping the pipe with geotextiles would help alleviate this problem, but the process can be time-consuming and cumbersome. Also, the arrangement of the holes along the pipe keeps a relatively low percentage of soil area open to aeration and drainage. Some of the disadvantages of the 4-inch perforated PVC pipe may be avoided by using a flexible drainage system.

A variety of flexible drainage materials currently are available. They all have a flexible plastic core that is wrapped with geotextile. The plastic core is made in a wide variety of forms that are designed to allow for large open spaces for drainage and aeration. The major variations between them are structural strength/load-bearing capacity and water flow potential.

The choice for the most appropriate style of flexible drainage material should be based on an assessment of site conditions and use. For example, if the site requires significant drainage measures and a connection to a storm sewer, it may be advisable to use the higher-density corrugated plastic drain. If the primary function of the system is aeration, a waffle-like plastic core will be sufficient.

Since the flexible materials are pre-wrapped with geotextile, installation is quicker and simpler than installing PVC pipe. Most of these materials can be fitted to pipes of other sizes and dimensions, so transition is possible to the pipes that extend to the surface, or to a storm sewer.

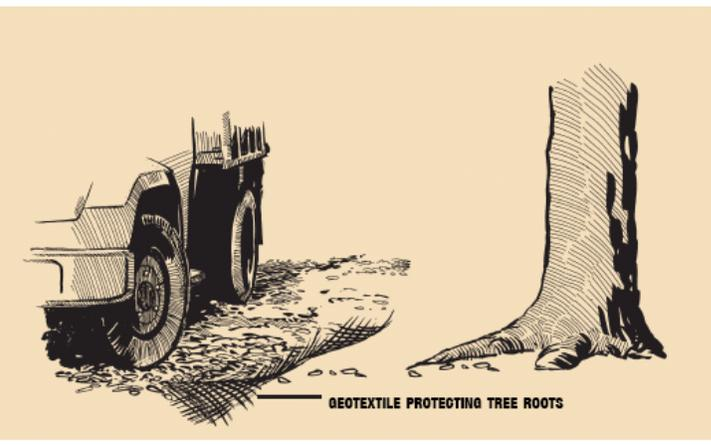


Figure 23. Two to 4 inches of mulch placed on a geotextile sheet protects soils from compaction caused by construction equipment and material storage.

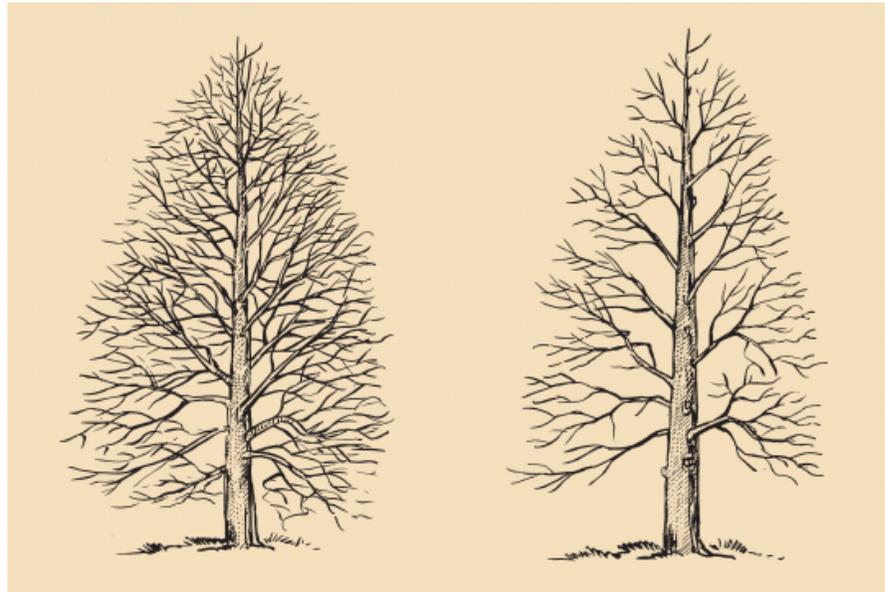
Unlike the 4-inch perforated PVC pipe, the entire surface area of these flexible drainage materials allows for maximum diffusion of air and water to expanding roots.

*Use geotextiles for temporary roads and storage areas.*

Soil compaction destroys soil structure, which takes many years to develop. Soil structure directly affects the aeration, drainage, and water-holding capacity of a soil. An inexpensive and recyclable way of protecting soil structure is to use a layer of heavyweight geotextile covered with about 4 inches of wood chips. This system will support the weight of a loaded cement truck and can be used on all construction sites for temporary roadways and materials storage areas.

*Retain a qualified arborist to perform tree maintenance services.*

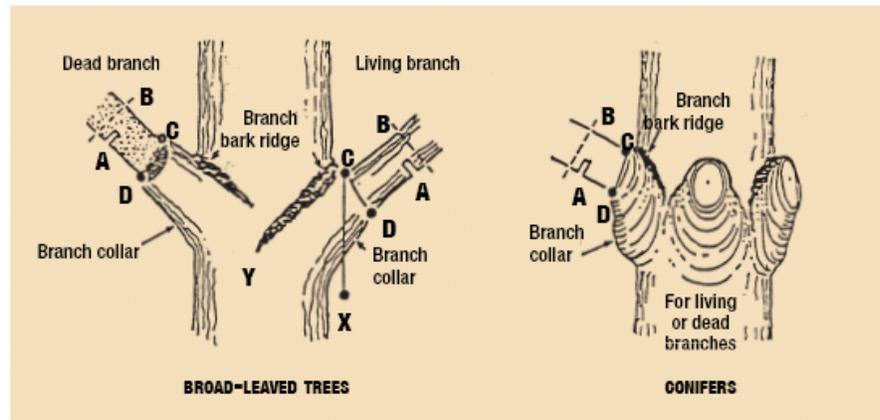
An experienced arborist can monitor tree health before and during construction. If necessary, this specialist can then water or fertilize the trees, or provide treatment for a pest or disease problem. Although care should be taken when working around all trees, some trees are more sensitive to construction than others. For example, older and larger trees may need specialized attention, such as fertilization and irrigation, if they are disturbed by root pruning, soil compaction, or other construction activity.



**Figure 24. Pruning should protect a tree's natural form. Well-pruned trees are similar in form and appearance to trees that have not been pruned.**

*Retain a qualified arborist to perform all required pruning.*

Construction workers untrained in pruning or other arboricultural practices often unintentionally damage trees while trimming them. Construction workers who trim trees often leave branch stubs, tear the bark, or remove more branches than necessary. The tree preservation plan should identify which limbs must be pruned to accommodate construction. Required pruning and removal of limbs can be better understood by staking construction footprints. Pruning should be based on the tree preservation plan and be performed by a qualified arborist before construction begins.

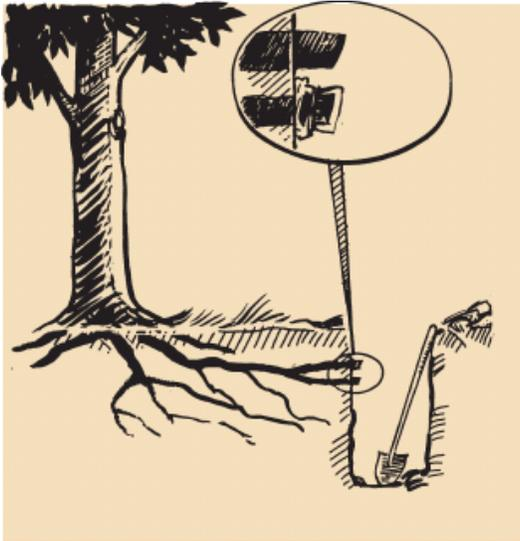


**Figure 25. Natural Target Pruning properly removes a branch while protecting the branch collar, which is essential for wounds to heal. First cut A, second cut B, and third cut C-D.**

*Retain a qualified arborist to perform all required root pruning.*

A tree's tolerance of root loss may vary greatly depending on its age, species, and health, as well as rainfall and soil quality. Some healthy young trees can survive after losing 50 percent of their roots, although their structure may be compromised. Other species are extremely sensitive to root pruning

and soil compaction. Avoid disturbing more than 25 percent of the roots within the dripline for any tree and do not disturb any roots within the dripline of old, valuable, or sensitive trees. Hire an arborist to provide supervision when exposing roots close to large, historic, or notable trees. Any root pruning should be done by, or under the direction of, a qualified arborist.



**Figure 26.** When digging near trees suitable for preservation, the first cut should be made by hand labor with shovels under supervision of an arborist. Exposed roots should be neatly cut with a sharp saw. To protect them from drying out, the ends of severed roots can be covered with a plastic sandwich bag held in place by a rubber band.

Consider using hand labor to expose roots in cut areas needed within or adjacent to a TPZ.

Exposing roots with a backhoe or other piece of equipment can tear roots, resulting in damage and decay. Instead, dig with hand tools to expose roots that may interfere with construction. During hot weather, wrap all roots exposed by trenching with dampened burlap if there is a delay in deciding whether the

roots should be preserved. If a footing or curb is being constructed, conflicting roots should be severed cleanly with a saw. Newly pruned roots over 3 inches in diameter should be protected from drying by covering the cut end of the roots with a plastic bag secured by a rubber band. During hot weather, cut areas where tree roots are removed or exposed should be covered with black plastic and kept damp until it is time to complete the work.

*Do not excavate utility trenches through a TPZ.* Injuring roots kills trees. The root systems of trees can be severely injured by trenches that are dug directly through them. Relocate utility trenches or use tunneling or boring equipment when installing underground utilities through a TPZ. Trenching with backhoes and other equipment can destroy entire root systems, while tunneling or boring under the roots has little effect.

**Figure 27.** After roots are exposed and cleanly cut, the soil around them should be watered and covered with black plastic during hot periods. Large equipment can be used for mass grading after tree roots have been protected.



*Do not use a bulldozer to selectively remove trees.*

Trees designated to be saved can be easily damaged by bulldozers during the removal of adjacent trees. When a bulldozer is used to remove a tree, the entire tree falls at once and its canopy can damage the branches and bark of adjacent trees meant to be preserved. Bulldozers also compact soils and destroy soil structure. Trained arborists can selectively remove trees without harming adjacent trees.

*Use geotextiles and other alternatives for driveways and patios.*

When constructing brick, stone, or concrete driveways and patios, it often is necessary to excavate the top 12 inches of soil and then compact the subsoil using heavy equipment. Geotextiles can be used to minimize the degree of soil compaction needed under driveways and patios. When installing

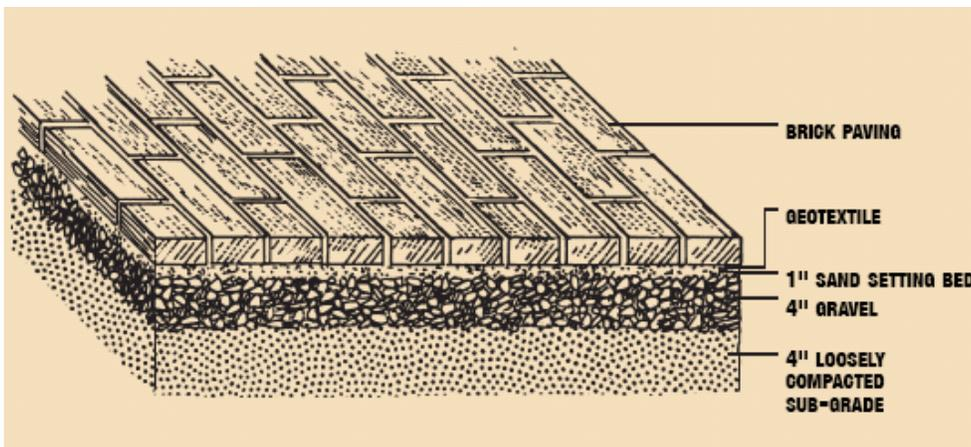
interlocking pavers, use geotextiles underneath to minimize the need for compacting the soil. A sand base placed over lightly compacted soil should be covered with a geotextile material to support pavers, patios, or driveways. Wood decks are excellent alternatives to hard-surface patios in areas where trees have been preserved. No removal or compaction of the soil is needed and decks have the added advantages of allowing water and air to reach covered tree roots.



*Do not remove the natural leaf mulch or organic litter from beneath trees.* Existing litter or supplemented mulch helps improve soil structure, allows better water infiltration, protects soil and roots from erosion, moderates soil temperatures, and adds

**Figure 28. Properly preserved trees will provide benefits for a lifetime.**

carbon and nutrients to the soil. Keep turf away from trees and install landscapes using native shrubs and other plants that will not damage trees preserved and incorporated into development.



**Figure 29. Brick patios and sidewalks can be designed to reduce soil compaction and root pruning.**



## Repairing Construction Injury

The most common causes of tree injuries are worker carelessness, grade changes, soil compaction, soil pollution, and the incorrect removal or trimming of trees. Depending on the extent of the injuries, trees may die shortly after construction is completed or their health may slowly decline over a number of years. Several techniques can help correct injuries caused by construction activities. Trees should be inspected for two years following construction for declining health, branch dieback, or poor foliage color.

### Soil Techniques

#### *Understanding structural fills*

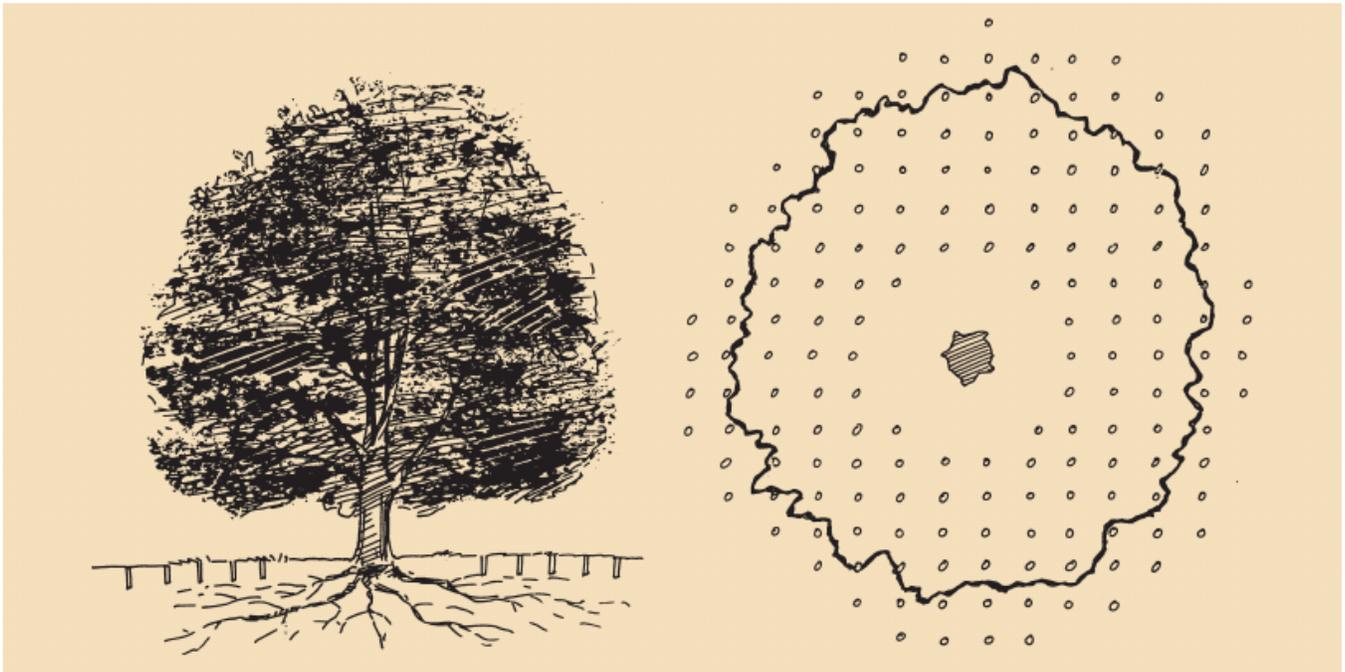
Structural fills are used to key-in slopes and provide heavily compacted pads for construction. In a structural fill, all the soil is removed until a soil horizon with a certain compaction rate is found. Removed soils are then replaced upon the compacted soil while being compacted with water. It does no good to provide aeration systems or other preservation techniques or to remove fills of this nature from near trees because roots have already been severed in the fill process. Structural fills should be avoided within the TPZ of trees suitable for preservation.

#### *Removing fill*

Fill can kill trees quickly, or it can kill them gradually over a number of years. The effect fill has on trees depends on a number of factors. If construction activity has changed the grade under or near a tree, all efforts should be made to restore the area to its natural grade. Trees not surrounded by fill have a noticeable trunk flare at the soil line, while trees buried in fill have no trunk flare (see Figure 20). Test holes can be dug at several points near the tree to determine how much fill has been added. Fill can be removed safely within one year after construction. A backhoe can be used to remove fill to within 4 inches of the original grade, but the rest should be removed by hand with shovels and rakes. Fill that has been in place for several years requires care during removal, and a qualified arborist should be consulted. Some trees survive the initial application of fill because their roots grow into the fill. For trees covered by fill for long periods of time, fill within 4 feet of the trunk should be removed to expose the trunk and buttress roots. If it appears that many new roots have grown and become established in the fill, the excavation should stop and the fill should be replaced. Fill should not be removed during periods of hot, dry weather. Exposure under these conditions could shock a tree by drying out the roots as well as the soil around them. The removal of fill can create a low spot around a tree that accumulates water. If inadequate drainage is a problem, a French drain or other drainage system must be installed to move standing water away from the tree.

#### ..... **HELPING INJURED TREES**

- Keep tree well watered during dry periods
- Fertilize lightly
- Provide a covering of mulch
- Remove deadwood
- Keep all pedestrian and vehicle traffic away
- Consider vertical mulching



**Figure 30. Vertical mulching can help repair compacted soils and help trees recover from root systems damaged by compacted soils and root removal.**

#### *Repairing soil structure using vertical mulching*

The poor structure of compacted soils can be improved by carefully drilling lines of holes in a concentric pattern beneath a tree. Each 2-inch diameter hole should be drilled to a depth of 12 to 18 inches (without injuring any large roots). The holes should be 2 feet apart, with the inner circle of holes located 3 feet away from the trunk and the last circle located 5 feet outside of the tree's dripline.

These holes can be left open or filled with a mixture of coarse sand and composted organic matter. The organic matter can be anything from composted leaves and grass clippings to composted sewage sludge. The sand gives the mixture some weight and strength, while the organic matter provides a food source for the soil microorganisms that are needed to help redevelop the soil structure. This process of filling the holes is called vertical mulching, and it is still experimental.

The structure of soil that has been damaged by compaction will return very slowly. It usually takes many years for the soil's drainage and aeration characteristics to return to the preconstruction levels. Compacted soils also can be helped by placing 3 to 4 inches of organic mulch over as much of the root system as possible. Keep this mulch several inches away from the tree trunks.

#### *Replacing damaged soil*

Soil that has been polluted or damaged beyond repair by pollution or heavy equipment should be removed and replaced. Damaged soil near trees should be removed with hand tools to avoid any further damage to roots. Although it may be better to use an ordinary top soil from the site or the locality, a loam-based soil that contains a balanced mixture of sand, silt, and clay also can be used. It should contain at least 1.5 percent stable organic matter. Soils with lower amounts of stable organic matter should have their levels of organic matter raised to 5 percent by adding composted yard wastes or sewage sludge. Replacement soils should not be ground or tilled too finely, as these processes destroy soil structure.

## Tree Techniques

### *Tree injury*

Tree limbs that have been broken or torn off during construction should be pruned according to recognized standards by a qualified arborist. If a tree trunk or butt has been damaged, the wound can be treated by removing dead and injured bark from around the wound with a sharp knife. Cut the loose bark away from the wound to form a clean, smooth surface of healthy wood and bark. Take care not to damage healthy tissue and do not widen the wound any more than necessary to remove damaged bark. Tree wound dressing does not stop decay and should not be used on limb or trunk wounds.

### *Fertilizing*

There are no general fertilizing recommendations that apply to all soils and trees. Healthy, vigorous trees usually do not need to be fertilized at all. To determine fertilizer needs, a soil test must be taken and analyzed by a reputable laboratory. This test is needed to determine the soil's pH and basic nutrient levels. Major nutrients include phosphorus, potassium, magnesium, and calcium. The laboratory should provide recommendations about how much of each of the basic nutrients should be applied. There has been a considerable amount of debate among highly respected arborists over the best method of applying nitrogen to trees that have been injured and placed under stress by construction activities. Some believe that high amounts of nitrogen should be applied to increase the tree's foliage production. Additional foliage would increase the photosynthetic capacity of the tree, which in turn would result in the production of more energy-rich carbohydrates. The tree could then use the additional carbohydrate to replace roots that were injured during construction. Others feel that only low amounts of nitrogen should be applied to prevent undue stimulation of growth and the development of too much foliage, which might reduce already low energy reserves in a stressed tree and require more water than the damaged root system could provide. Too much foliage could therefore cause increased stress to the entire plant. We recommend that nitrogen-based fertilizers be applied in slow-release forms in light to moderate amounts. Recipes do not guarantee the correct application of fertilizers. The tree and the site that it occupies must be understood before fertilizing can be used in a beneficial manner. It is best to have a recommendation from an arborist or other specialist for a specific tree. To provide some guidance, a general recommendation for the application of fertilizer for a tree injured by soil compaction or root damage is to supply 2 to 3 pounds of slow-release nitrogen per 1,000 square feet of surface area to be fertilized. An example of surface area that should be fertilized is the area beneath a tree's canopy. If part of the root system is covered by a paved surface, apply a higher rate to the part that is not covered. Do not apply more than 3 pounds of nitrogen per 1,000 square feet. To calculate the pounds of fertilizer needed to supply a certain amount of nitrogen, divide the amount needed by the nitrogen percentage of the fertilizer. For example, if 80 pounds of nitrogen were needed, and a 25-14-14 fertilizer were being used, you would divide 80 by 0.25. The result would be 320 pounds of fertilizer. The fertilizer should be broadcast evenly beneath and slightly outside the dripline of the tree. Fertilizer can be broadcast over turf. Combining fertilizer with vertical or broadcast mulching can increase the overall benefit to injured trees and soils. The timing of fertilizer application also is under debate. One recommendation is to apply fertilizer to young trees before leaves are formed in the early spring to promote growth. Fertilizer should be applied lightly for mature and old trees in late summer or early fall to promote nutrient storage.

### *Irrigation*

During periods of hot weather and little rain, irrigation can be used alone or in combination with fertilizing to improve the health of a tree that has been heavily damaged by soil compaction or root removal. In the northeastern United States, a thorough soaking by rain every two weeks during the growing season is more than adequate to meet the needs of injured trees. Irrigation is not necessary when rainfall is adequate. When trees have been injured by construction and are experiencing periods of drought or hot weather, the amount of water needed for irrigation can be estimated by measuring a tree's DBH and using 20 gallons of water per inch of measured diameter. For example, a tree measuring 10 inches DBH would require 200 gallons of water applied once a week during a drought period. Apply the water slowly and deeply by soaking or injecting the soil. In clay soils, apply water first and allow it to soak in, then apply it again. A water furrow or basin may be required to contain water

when irrigating through soaking. Do not cultivate near a tree to construct a water furrow. Water should be applied within the outer two-thirds of the tree's root zone, or dripline. Large trees require more application points. Allow the soil near a tree to dry between irrigations. In most cases only one irrigation is necessary to assist a tree through a drought period.

To determine water flow, place a hose in a five-gallon bucket. Keep track of the time that it takes to fill the bucket. If it takes five minutes to fill the bucket, then you will know that the flow rate is 1 gallon per minute and it will take 100 minutes to apply 100 gallons. Use common sense when applying large amounts of water. Take your time and avoid causing erosion or flooding of surrounding areas. Move the hose around the tree to irrigate the entire area.

## **After Construction**

Despite the fact that a tree or woodland is preserved and incorporated within a development, some trees are likely to die each year because of the additional landscaping and construction activities of homeowners and inadequate tree care and maintenance. Various activities can injure a tree. These include grading; trenching and paving; building sidewalks, driveways, pools, patios, and home additions; landscaping lawns and lots; and pruning trees incorrectly by topping. Homeowners should provide proper care for preserved trees and should design compatible landscapes and amenities that protect the health of the trees. The following practices can help ensure that trees will remain healthy long after construction has been completed.

### *Supply homeowners with information.*

Developers and realtors can supply home buyers with simple information about the value of their trees, how they can be protected, and experienced arborists in their area.

### *Keep competing vegetation, especially grasses, as far away from trees as possible.*

Not only will grass compete with trees for water and nutrients, it also may produce chemicals that inhibit the growth of trees.

### *Consider alternative landscaping.*

The areas beneath trees should be covered with mulch or planted with native ground covers. There are many species of native plants that provide a variety of sizes, colors, and forms for landscaping beneath preserved trees. A landscape can be created that not only protects trees, but also highlights native plants, conserves water, and reduces the need for fertilizers and pesticides.

### *Use mulch.*

Mulch provides many benefits for trees. It moderates soil temperatures, reduces soil moisture loss, reduces soil compaction, improves soil structure, provides nutrients, and reduces winter drying. Mulch also keeps mowing equipment away, thus avoiding serious bark injuries. These benefits result in more root growth and healthier trees. Observe the following guidelines when applying mulch:

2. The best mulch materials to use are composted leaves, wood chips, bark nuggets, or pine needles. Avoid plastic, stone, sawdust, finely shredded bark, and grass clippings.
2. Mulch should be applied from the dripline to the trunk, but mulch should not be placed against the trunk. The mulch will retain too much moisture if left against the trunk, which may result in disease and decay.
3. If it is not practical to mulch from the dripline to the trunk, minimum mulch circles should be 3 feet for small trees, 8 feet for medium trees, and 12 feet for large trees.
4. Before applying mulch it is best to kill grass with an approved herbicide. Mulch should be applied directly to the soil surface or on top of the dead grass; plastic barriers should not be used.
5. The mulch layer should be 2 to 4 inches deep—do not create mulch mountains.
6. To avoid root disturbance, mulch should not be removed. Additional mulch can be added yearly to maintain a 2- to 4-inch depth.



**Figure 31. Many species of native plants can provide a variety of sizes, colors, and forms to interesting landscapes. Keeping grasses away from preserved trees can increase a tree's health and appearance.**

*Improve the aeration and drainage of compacted soils.*

Aerate compacted soil if the final landscape has already been installed, or if there are large trees on the site that have roots growing throughout the compacted area. Aeration can be done to shallow depths with standard core aerators, or to deeper depths by vertical mulching with power drills or augers.

*Prevent additional soil compaction.*

Build wooden decks instead of cement or stone patios. Cement or stone patios require the removal of soil and the compaction of the base. Use mulches, preferably with a geotextile base, to prevent compaction in heavily used areas or storage areas.

*Irrigate and fertilize when needed.*

Follow the recommendations in the construction injury section for irrigating and fertilizing trees damaged by construction.

*Provide proper maintenance.*

Trees are often severely damaged by topping and other improper pruning methods. Employ only qualified arborists to prune and perform other maintenance. Newly planted trees should be well cared for. Irrigate newly planted trees during dry periods for the first five years to increase establishment and growth.

**For More Information**

American National Standards Institute. 1988. *American National Standards for Tree Care Operations—Pruning, Trimming, Repairing, Maintaining, and Removing Trees, and Cutting Brush— Safety Requirements*. American National Standards Institute, 1430 Broadway, New York, NY 10018. (Standards for safe tree care operations.)

Arent, R. 1994. *Rural by Design*. American Planning Association, 1313 E. 60th Street, Chicago, IL 60637. (312) 955-9100. (Solutions, examples, and sound advice on open space and cluster planning.)

Bucks County Planning Commission. 1991. Model Natural Resource Protection Standards. Bucks County Planning Commission, The Almshouse Building, Neshaminy Manor Center, Doylestown, PA 18901. (215) 345-3400. (Model provisions for the protection of natural resources.)

Childs, R. D. 1994. *New England Management Recommendations for Insects, Diseases and Weeds of Shade Trees and Woody Ornamentals*. University of Massachusetts Cooperative Extension, Amherst, MA. (A guide to dealing with insect and disease concerns.) City of Thousand Oaks. 1987. City of Thousand Oaks Oak Tree Preservation Ordinance. City of Thousand Oaks, CA 91360. (One of the first successful tree preservation ordinances in California.)

Commonwealth of Pennsylvania. *Act 247 of 1968, as amended. Pennsylvania Municipalities Planning Code*. Pennsylvania Department of Community Affairs, Harrisburg, PA 17120. (717) 787-0791. (The state code that allows land use planning in Pennsylvania.)

Davidson, J. A., and M. J. Raupp. 1993. *Landscape IPM Guidelines for Integrated Pest Management of Insect and Mite Pests on Landscape Trees and Shrubs*. Bulletin 350, University of Maryland Cooperative Extension, College Park, MD. (A helpful guide to integrated pest management.)

Dirr, M. A. 1990. *Manual of Woody Landscape Plants: Their Identification, Ornamental Characteristics, Culture, Propagation and Uses*. 4th Edition. Stipes Publishing Company, Champaign, IL 61820. (Detailed characteristics of many landscape trees.)

Fairfax County Virginia Board of Supervisors. 1986. *Vegetation Preservation and Planting*. Fairfax County Board of Supervisors, Fairfax County, VA. (A progressive county publication concerning vegetation preservation.)

Fazio, J. 1992. *Trenching and Tunneling Near Trees*. The National Arbor Day Foundation, 100 Arbor Avenue, Nebraska City, NE 68410. (A simple guide to trenching and tunneling near trees.)

Harper, J., M. Mantel, and L. Propst. 1990. *Creating Successful Communities: A Guidebook to Growth Management Strategies*. The Island Press, Washington, D.C. (Case studies on programs to preserve natural resources within community growth and development.)

Harris, R. W. 1993. *Arboriculture: Care of Trees, Shrubs, and Vines in the Landscape*. Prentice-Hall, Inc., Englewood Cliffs, NJ 07632. (Explanations of a wide variety of arboricultural practices.)

Heller, P. R., W. K. Hock, G. A. Hoover, and G. W. Morman. 1991. *Woody Ornamental Pest Control Suggestions*. Penn State College of Agricultural Sciences, University Park, PA. (Practical advice on insect problems.)

Hightshoe, G. L. 1978. *Native Trees for Urban and Rural America. A Planting Design Manual for Environmental Designers*. Iowa State University Research Fund, Ames, IA 50011. (Characteristics and use of native plants.)

International Society of Arboriculture. International Society of Arboriculture, P.O. Box GG, Savoy, IL 61874-9902. (217) 355-9681.

1994. *Guide for Plant Appraisal*. (Guide for appraising the value of trees and other landscape plants.)

1995. *Certified Arborists Study Guide*. (Comprehensive study guide on tree maintenance for the certified arborist test.)

1995. *Tree-Pruning Guidelines*. (Guidelines for the correct pruning of landscape trees.)
1997. *Plant Health Care for Woody Ornamentals*. (A professional's guide to preventing environmental stresses and pests of trees.)
1998. *Trees in Development*. (A professional's guide to preserving trees in development.)
- Koehler, C. S., R. H. Hunt., D. F. Lobel, and J. Geiger. 1984. *Protecting Trees When Building on Forested Land*. University of California Cooperative Extension, Berkeley, CA 94720. (A guide to preserving trees in forests.)
- Metheny, N. P., and J. R. Clark. 1994. *A Photographic Guide to the Evaluation of Hazard Trees in Urban Areas*. International Society of Arboriculture, P.O. Box GG, Savoy, IL 61874-9902. (217) 355-9681. (Recognizing and managing hazardous trees. Includes many helpful pictures.)
- McHarg, I. L. 1969. *Design with Nature*. J. Wiley and Sons, Inc., New York, NY. (A classic book on how to consider nature in community design.)
- Miller, L. M., D. Rathke, and G. Johnson. 1993. *Protecting Trees from Construction Damage*. Minnesota Extension Service, 20 Coffey Hall, Saint Paul, MN 55108-6064. (A comprehensive guide that considers the effects of construction on plants.)
- Moll, G. 1986. "How to Select a Wooded Homesite: Part 1 and Part 2." In *American Forests*, July and August Issues. American Forests, 1516 P Street, NW Washington, D.C. 20005. (Two informative articles on selection of and working with wooded lots.)
- National Arbor Day Foundation. *Tree City USA Bulletins*. The National Arbor Day Foundation, 100 Arbor Avenue, Nebraska City, NE 68410. (A series of informative brochures on a variety of topics including preserving trees in development, proper pruning techniques, hazardous trees, and topping trees.)
- Shigo, A. L. 1990. *Modern Arboriculture: A Systems Approach to the Care of Trees and Their Associates*. Shigo and Trees Associates, 4 Denbow Rd, Durham, NH 03824-3105. (217) 355-9681. (Innovative and practical book on tree care and maintenance.)
- Shigo, A. L. 1986. *A New Tree Biology*. Shigo and Trees, Associates, 4 Denbow Rd, Durham, NH 03824-3105. (217) 355-9681. (A guide to a better understanding of trees, their problems, and proper tree care.)
- USDA Forest Service. 1993. G. Mason (Ed.) *An Ecosystem Approach to Urban and Community Forestry*. USDA Forest Service Northeastern Area, State and Private Forestry, 5 Radnor Corporate Center, Radnor, PA 19087-4585. (610) 975-4131. (Holistic land use planning, growth management, and community forest management.)
- Visit Penn State's College of Agricultural Sciences on the Web: [www.cas.psu.edu](http://www.cas.psu.edu), Penn State College of Agricultural Sciences research, extension, and resident education programs are funded in part by Pennsylvania counties, the Commonwealth of Pennsylvania, and the U.S. Department of Agriculture.
- This publication is available from the Publications Distribution Center, The Pennsylvania State University, 112 Agricultural Administration Building, University Park, PA 16802. For information telephone 814-865-6713.

This publication is available in alternative media on request. The Pennsylvania State University is committed to the policy that all persons should have equal access to programs, facilities, admission, and employment without regard to personal characteristics not related to ability, performance, or qualifications as determined by University policy or by state or federal authorities. It is the policy of the University to maintain an academic and work environment free of discrimination, including harassment. The Pennsylvania State University prohibits discrimination and harassment against any person because of age, ancestry, color, disability or handicap, national origin, race, religious creed, sex, sexual orientation, or veteran status. Discrimination or harassment against faculty, staff, or students will not be tolerated at The Pennsylvania State University. Direct all inquiries regarding the nondiscrimination policy to the Affirmative Action Director, The Pennsylvania State University, 328 Boucke Building, University Park, PA 16802- 5901, Tel 814-865-4700/V, 814-863-1150/TTY.  
© The Pennsylvania State University 2005

Produced by Information and Communication Technologies in the College of Agricultural Sciences  
CAT UH122 Rev3M4/05ps4175

#### ACKNOWLEDGMENTS

Prepared by William Elmendorf, assistant professor of community forestry; Henry Gerhold, professor of forest resources; and Larry Kuhns, professor of horticulture.

Illustrations on cover, inside front cover, and pages 1, 2, 7, 8, 11–13, 15–21, and 24 by Jeffery Mathison.

This publication was prepared by Penn State with guidance from the Pennsylvania Urban and Community Forestry Council and support from the Pennsylvania DCNR Bureau of Forestry. For more information, contact the Pennsylvania Urban and Community Forestry Program, School of Forest Resources, The Pennsylvania State University, 108 Ferguson, University Park, PA 16802; (814) 863-7941.



**APPENDIX J - Publication: “Understanding Tree Planting in Construction-damaged Soils” by William Elmendorf of The Pennsylvania State University (2008)**

Note: This publication is included, as written by the author, in this appendix for general information for the public. Some minor differences may exist in definitions used by the author and those in the glossary of this manual.

**Made Soils**

Soils found in commercial, residential, and other landscapes that have been involved in construction are most likely different from soils found in places that are undeveloped or uncultivated. Some people refer to soils in developed places as fabricated or “made soils.” Because of grading (soil fill and removal), equipment movement, cleaning equipment, and other activities in areas that have undergone construction, made soils can be highly mixed and altered. These soils can change in fertility, pH, compaction, and drainage from foot to foot. As a result, soil maps provide little useful information about the characteristics and capacities of construction-damaged soils.

When planting trees and other plants in construction-damaged soils, you most likely are dealing with made soils both horizontally and vertically. These fabricated soils can be heavily compacted, polluted, and unfertile, full of trash and debris, have unhealthy high or low pH ranges, and have strange transition zones (hydrological differentiation) between mixed and



*Soils in these developed areas have been stripped of organic material, compacted, and have a certain amount of garbage and debris.*

		Diameter of Particles			
Millimeters	2.0	0.05	0.002	0	0
Inches	0.080	0.002	0.00008	0	0
gravel, stones	sand	silt	clay		
Particles visible with the naked eye		Particles visible under microscope	Particles visible under electron microscope		

*Diameters of sand, silt, and clay particles. Sand is the largest soil particle and clay is the smallest.*

crushed layers. These traits can all negatively impact tree establishment (root growth to support plant growth), normal growth and appearance, and plant longevity. There are many examples of construction-damaged soils. Compaction by people or equipment crushes soil structure, impeding air, water, and root movement. Organic soils are

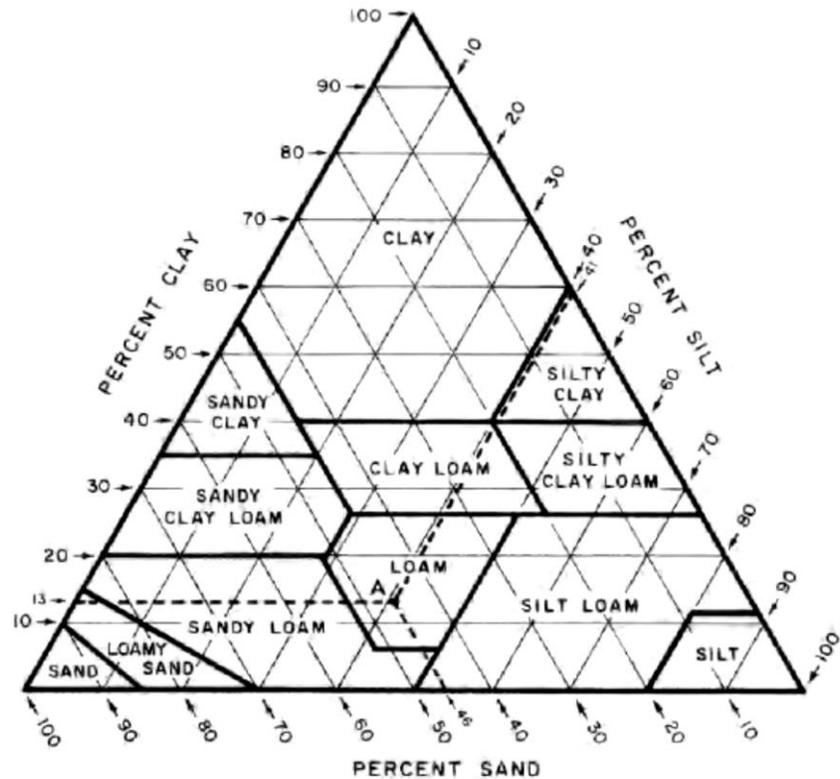
often stripped and removed from construction areas, leaving compacted, mostly clay soils. Transition

zones, caused by dumping one type of soil on top of another, are often impermeable barriers to water, air, and roots. For successful tree and plant growth, you need to understand the characteristics and capacities of the soil in which you are going to plant, especially soil damaged by construction.

## Soil Texture

Soil texture is the amount of sand (larger soil particle size), silt, and clay (smallest particle size) present in any soil. Texture affects water percolation, water retention, aeration, nutrient capacity and retention, and root and plant growth.

In natural soils, soil texture is provided to a great extent by a soil's parent material, the underlying rock, and how this material has interacted with air, water, cold, heat, gravity, and other environmental conditions over time. Because of mixing, dumping, and removing in soils impacted by construction, it can be difficult to determine what the parent material, or basis, for a soil's texture is, and soil texture can change in any given place of a developed landscape.



*The "soil triangle" shows different soil textures. Most soils of agricultural importance are some type of loam.*

## SANDY TEXTURE

Typically, larger-grained, sandy-textured soils have better water percolation and aeration than smaller-grained, clay-textured soils, but their ability to retain and provide water and plant nutrients is lower. Water and nutrients simply leach through sandy soils quickly. Soils with sandy types of textures are harder to compact but can be extremely droughty and infertile—think of the beach. With large particle sizes, sandy soils have better water and air movement because of more and larger soil pores. Pores are spaces between soil particles that can be filled with and help move water and air. The presence of sand particles also makes any soil more friable or loose and promotes root growth.

## SILTY TEXTURE

Silty soils have particles that are intermediate in size between sand and clay. Because of smaller particle size and smaller pore spaces, silty soils have a slower water-intake rate but a higher water- and nutrient-holding capacity than sandy soils. Water does not drain through these soils as quickly, but they are also more easily compacted than sandy soils. Although there are few truly silt soils in Pennsylvania, some portion of silt is an essential part of a desirable soil.

## CLAY TEXTURE

Because of their very small particle size and the associated small size of soil pores, clay soils are much easier to compact, which affects water, air, and root movement. Clay particles are stickier and have the ability to bind both water and soil nutrients. One property of clay is an attraction for positive nutrient

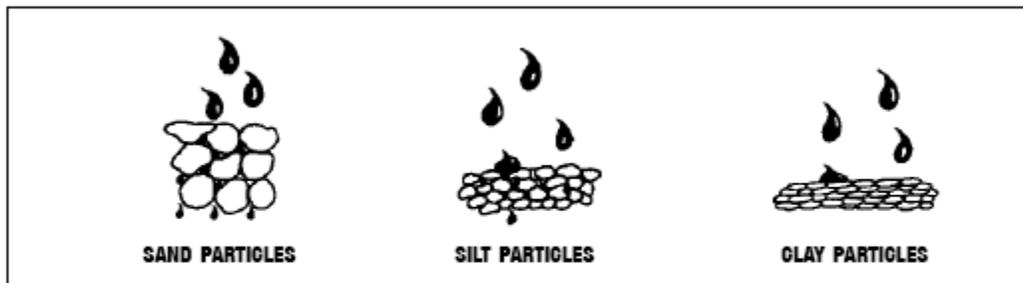
ions such as calcium, magnesium, and ammonia. Because of this, clay soils can hold and store large amounts of these plant nutrients. On the other hand, negative plant nutrient ions such as nitrate, phosphate, and sulfate are repelled by clay particles and are only stored for plant use to the extent they are dissolved in any water held in soil pore spaces. Clay is a major ingredient of a healthy soil, but in some cases, clay soils can bind water and nutrients so tightly that they are unavailable to plant roots. As with sand and silt particles, a portion of clay particles is desirable in healthy soils because of high nutrient- and water-binding or holding capacity, which adds to the fertility of a soil.

## LOAM TEXTURE

A loam soil has intermediate, approximately equal properties of sand, silt, and clay. Loam soils have good characteristics in terms of water movement and storage, nutrient holding or fertility, and friability for root growth. For many plants, a sandy/loam soil (e.g., topsoil) is the desired soil for good plant growth and survival. This type of soil texture shares all the positive traits that sand, silt, and clay textures provide.

### **How to Explore Soil Texture**

Soil texture can be explored by picking up and gently rubbing a soil sample between your thumb and fingers. It is helpful to dampen the soil to feel the amount of clay—or plasticity. The way a damp soil develops a ribbon as it is rubbed gives a good idea of how much clay is present. Sandy soils feel gritty, and silt has a floury feel to it when dry and is smooth and not clayey or sticky when wet. To help you explore through rubbing what type of soils you have, different types of soils are described below. The sources for these descriptions are Phillip J. Craul's *Urban Soils: Applications and Practices* (John Wiley and Sons, 1999) and Nyle C. Brady's *The Nature and Properties of Soils* (Prentice Hall, 2007).



***The amount of sand, silt, and clay particles found within a soil make up a soil's texture. Soil structure is how these particles are grouped together.***

## SANDY

Soils where the sand makes up 70 percent or more of the material by weight are classified as sandy. They are not sticky as the heavier clay and loam soils are, but they are loose and single grained. Squeezed in the hand when dry, they will fall apart. Squeezed when dampened, they will form a cast or ribbon that will fall apart if touched.

## LOAM

Most soils of agricultural importance are some type of loam. A loam soil has a relatively even mixture of different grades of sand, silt, and clay. They exhibit light or sandy (good drainage) and heavy or clay (nutrient- and water-holding capacity) properties in about equal proportions. Loams are mellow with a somewhat gritty feel yet fairly smooth and slightly plastic or clayey. Squeezed when dry, they will form a ribbon that will bear careful handling, and the cast formed by squeezing the moist soil can be handled quite freely without breaking. They are classified by the amount of sand, silt, and clay they contain: sandy loam, silt loam, and clay loam.

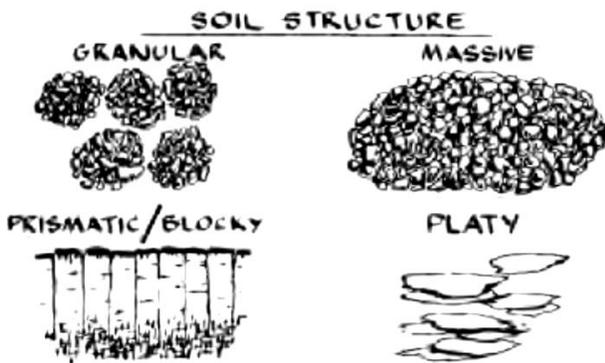
## CLAY

Clay soils have between 35 and 40 percent clay. They are fine-textured soils that usually form hard lumps or clods when dry and are quite plastic and sticky when wet. When the moist soil is rolled, it will form a long, flexible ribbon that will not break or fall apart.

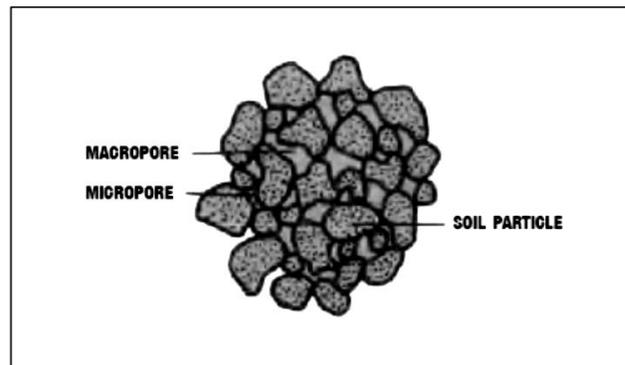
### Soil Structure

Soil structure is how the individual soil particles (sand, silt, clay) are arranged, aggregated, held, or come together in peds or clods. Thus, the size and form of soil aggregation is known as soil structure. Good soil structure allows for water and air infiltration and movement, as well as for root growth. Soil structure is developed over time through rain, frost, or other weather impacts. It is also affected by the amount and type of organic material that leaches into a soil over time. Although developed over time in nature, structure can be destroyed quickly by machinery, grazing livestock, cultivation, or other human impacts.

Typical types of soil structure include granular, blocky, prismatic, massive, and platy. Soil texture influences the type of structure a soil can have (e.g., a sandy soil has granular structure and clay soil has blocky structure), and both texture and structure affect the movement of air, water, and roots. Sandy soils often have little or no structure, while clay structures can have very heavy peds or clods (blocky or prismatic structures). It is important to have well-developed structures in heavy clay soils to allow for water, air, and root movement.



*Four examples of soil structure. Granular would be related to sandy soils, prismatic and blocky to clay soils.*



*Compaction smashes a soil's pore spaces, stopping air, water, and root movement.*

Structure is crushed and destroyed by compaction or smashed and destroyed by rough treatment. In soils that have been damaged by construction, structure is often compressed, crushed, or compacted—especially in clay soils. This means soil pore spaces are crushed and a soil becomes layered (platy) and water, air, and roots have a difficult, if not impossible, time moving into and through the soil. Also, compacted soils, because of a lack of pore space, tend to have poor gas exchange and levels of CO<sub>2</sub> produced by root respiration build up in the soil, slowing root respiration and growth. This build-up of CO<sub>2</sub> also happens in soils that are highly saturated for periods of time because of poor drainage or over irrigation.



*This soil's structure has been crushed and destroyed by compaction or mashed and destroyed by rough treatment.*

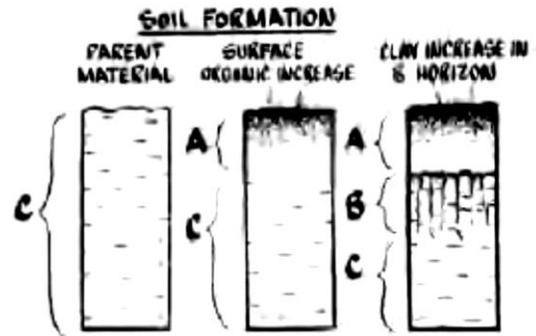
## Soil Structure Is Destroyed by Compaction

Compaction (or destruction of soil structure) is a huge problem when planting trees and other plant materials in developed landscapes and can be measured by soil bulk density. Bulk density is the mass (weight) of a dried soil



*As shown in these three photographs, soil amendments are applied and cultivated throughout the planting area, not just the planting hole.*

material, or humus. More humus and larger "A" horizons are found in soils (1) in cooler climates than in hot climates; (2) in wetter climates than in dry climates; and (3) under grasslands rather than under forests. The "B" horizons form very slowly in a soil and are an accumulation of clay in a layer beneath the "A" horizon. The "B" horizon builds up as a result of the downward movement of fine particles by



*Example of very simple soil horizons.*

per unit bulk volume, which includes both solids and the quantity of pore space. Because of the amount of uncompacted pore space, soils that are uncompacted, loose, and porous will have lower weights per volume. Soils that are more compacted will have higher weights per volume because their pore spaces have been destroyed, allowing for more soil in any given volume. Soil compaction, whether surface or subsurface, can also be measured by a penetrometer. A penetrometer is a tool that mimics a plant root. Most plant root growth is restricted at a penetration resistance of 300 pounds per square inch, and a penetrometer measures the resistance in pounds per square inch of a soil to a rod that is driven into it at approximately 1 inch per second.

### Soil Horizons and Profiles: Usually Destroyed by Compaction

As weathering continues over long periods, a number of changes occur that cause distinctly visible layers in a soil. These layers are called horizons and the sum of horizons for a soil is called its profile. Simple soil horizons are designated by the letters "A," "B," "C," going down from the surface. The first (lowest) horizon in a young soil is the "C" horizon, or the weathered parent material. With more weathering, time, and other forces, other horizons develop. The upper layer of many soils is a dark-colored zone that extends downward a few inches from the surface. This is the "A" horizon and its dark color is due to well-decomposed organic

percolating water and the formation of clay particles by chemical reactions in a soil over time. As with soil texture and structure, soil horizons and a soils profile are usually destroyed by construction. As an example, in most developments “A” organic horizons are removed, leaving only the “B” horizon of clay, which forms a barrier to water and air penetration and root growth when compacted.

### Soil Problems Found in Construction-Damaged Soils

Soil compaction, high (alkaline) or low (acidic) pH, and simply the amount of fertile soil available for root growth are three serious concerns when planting in constructed landscapes such as parking lots, patios, sidewalks, and compacted yards stripped of their organic horizons. In Pennsylvania, high-pH soils seem to be more abundant than low-Ph ones. Loss of organic material in the “A” horizon, compaction of underlying horizons, and soils containing pollution and debris can be helped by (1) replacing poor soils in the planting area (e.g., use of a high quality topsoil or a prescribed structural or other designed soil); (2) loosely breaking up existing soils that are decent but compacted using a shovel, air spade, or vertical mulching within proper soil moisture content; (3) carefully amending and cultivating whole planting areas, not just the planting pit, with composted organic material; and (4) choosing plant materials that are tolerant of compaction, drought, poor aeration, and low fertility.

### Breaking Compaction

Air spades and vertical mulching can be used to relieve compaction and help fertility in soils under existing trees. However, when working with soils, you need to pay close attention to the soil moisture content. Working a soil that is too dry can pulverize it, destroying the structure. Working soils that are too wet actually increases compaction. If the soil smears when dug or if water is visible within the soil pores, the soil is too wet. Vertical mulching is



**Radial trenching can be used to break compaction for new and mature trees.**

carefully drilling lines of holes (12 to 18 inches deep and 2 feet apart) in concentric patterns beneath a tree and filling them with a composted organic material. This is often combined with irrigation and broadcast fertilization of a nitrogen-based fertilizer in slow-release forms in light to moderate amounts (e.g., 25-14-14). Fertilization amounts should be based on a soil test and the possibility of irrigation. Irrigation amounts should be based on past irrigation and rainfall and



**Air spades (radial trenching) can be used to break compaction under existing trees. Exposed roots must be protected from desiccation.**

recognized standards (e.g., 20 gallons of water per inch of tree diameter at 4.5 feet on the trunk). Air spades can be used to remove or fracture compacted soils in large areas, trenches, or spokes through the root zone. If poor fertility or polluted soils are removed, they should be replaced with a high- quality topsoil. Roots and soils must be protected from the force of the air spade and from weather, such as cold and hot temperatures. Do not expose tree roots on particularly hot or cold days. When digging larger planting holes and radial trenches to relieve compaction in decent, fertile soils, do not smash

soils that you are going to replace as this will destroy structure. Loosely dig these soils and break them apart with a shovel.

### Structural Soils

Structural soils developed at Cornell University can be used under sidewalks, parking lots, patios, and other confined planting areas that have to be compacted to support the weight of asphalt or cement.

The structural soil mix of crushed stone provides both a penetrable, fertile rooting volume and a load-bearing service for asphalt or concrete. The three components of the mix are an angular crushed stone (to provide a skeleton to hold weight), a clay soil (to provide for nutrient- and water-holding capacity), and a small amount of hydrogel (to bind soil and stone together). The actual mix is patented by Cornell University and contractors must be licensed to create these soils at the construction site. A ratio of 80 percent stone, 20 percent clay, and a small amount of hydrogel is recommended. Structural soils must be mixed carefully using the correct gravel size, and they cannot be transported very far because the clay soil will separate from the gravel.



*Structural soils can be used under new sidewalks and parking lots, especially those being removed and rebuilt.*

### Concerns with Structural Soils

As with many recommendations, there are concerns about using structural soils in every planting case. These include (1) proper structural root growth in trees planted only in the gravel of structural soils; (2) proper mixing and the fact that these soils cannot be transported long distances after mixing because the components will separate; (3) the clay and hydrogel components can actually hold water from plant roots and expand; and (4) use of limestone gravel, which drastically increases pH. There are other designed soils besides structural soils. One solution is to have a knowledgeable person involved in selecting the type of soil that will be used when replacing or amending existing soils.



*Although 5 by 5 by 3 feet to 6 by 6 by 3 feet are the recommended minimum cutouts, larger planters such as 6 by 12 by 3 feet should be used to plant large trees in downtown areas.*

## Considering pH

The ability of plants to withdraw and use nutrients from soil is affected by its pH. Most plant materials prefer a slightly acidic pH. Many trees and plants (e.g., pin oak, red oak, red maple, and sweetgum) will not grow in high-pH (alkaline) soils, but many soils in the limestone regions of Pennsylvania and around construction sites (because of the amount of cement and limestone gravel used) are higher in pH. Problems with pH and altering unhealthy pH ranges can be difficult to deal with, especially after trees have been planted. Do not rely on liming to raise pH or sulfurizing to lower pH. These are short-term treatments affected by leaching and other forces. They will fail to provide assistance in the long term when pH is a concern. If pH is a concern, plant material should be selected that can handle both high and low pH (e.g., zelcova, Kentucky coffee tree, ginkgo, London plane).

## Sidewalk and Other Cutouts

Cutouts for trees in parking lots, sidewalks, and patios should be a minimum of 5 by 5 by 3 feet; 6 by 6 by 3 is a minimum recommended by some, but bigger is better (e.g., a cutout 10–12 feet long, 5–6 feet wide, and 3 feet deep is preferred to support one large growing tree). However, allowing that much space may be impossible in some situations. The depth of the soil available for rooting volume should be at least 3 feet for wind-firmness. Structural or other designed soils can be used to expand the rooting area while allowing for the placement of concrete.

Construction debris, gravel, and other waste should be removed from parking lots, sidewalks, and other planters. If structural or other designed soils are not being used, poor soils in planting cutouts should be replaced with high-quality topsoil. Remember that replacement soils and any amendments must be mixed in with original soils at the bottom and sides of the planting areas to prevent transition zones.

## A Note on Soil and Planting Cutout Size

Many people recommend larger cutouts with a minimum available rooting volume of at least 800 cubic feet per tree. These are extremely large areas (10 by 10 by 8 feet) and may not be available in all planting situations, especially when working with older planting areas that will not, or cannot, be redesigned or rebuilt. Again, structural or other designed soils can be used in new construction to increase rooting volumes and allow for concrete placement. But, planting trees in existing sidewalks can be a challenge. Sometimes, in confined places such as existing sidewalks, a decision must be made whether to plant a tree or not. If a tree is planted in less than the minimum planting cutout size recommended in this publication (5 by 5 by 3 feet), problems with hardscape damage should be expected, including issues of tree size, health, and longevity, and the strength of root structure. By providing the largest planting area possible and planting an appropriate tree species, these concerns can be minimized. It is also our opinion that minor hardscape damage, smaller mature tree size, and other problems are offset by the economic and environmental benefits that a reasonably healthy tree will provide a downtown area, a parking lot, or another populated area over time.





*Large sidewalk cutouts and innovative planting design should be used for larger trees.*

### **A Note on Organic Materials and Amendments**

Although the organic fraction or component of a fertile soil is usually small (1 to 5 percent by weight or around 10 percent by volume), it is important in providing a reservoir of nutrients and water and in improving the friability and structure of soils. Soil microorganisms must break down organic compounds to provide for essential plant nutrients—a process known as mineralization. Amending soils with organic materials can help improve water-holding capacity and fertility by affecting both texture and structure. Over time, organic materials provide gums that can help bind together smashed soil particles, improving structure. But, as has been pointed out by a number of authors such as Phillip and Tim Craul, the addition of large amounts of organic material is usually necessary to alter the characteristics of highly damaged or modified soils. Adding excessive organic material (usually more than 20 to 30 percent on a volume basis) causes a number of problems such as soil settlement and increase of water-holding capacity to a point where soils stay wet for long periods. Both problems are detrimental to root growth and function, especially in highly clay soils. Undue wetness creates unfavorable aeration conditions, increases carbon dioxide in soils, and can actually impede root function, the breakdown of organic material, and the release and use of plant nutrients. Soil texture can be modified by the addition of coarse sand or clay, depending on the desired change. Water-holding capacity, bulk density, and drainage are all modified by these amendments, but these modifications are beyond the intent of this publication. If dealing with heavily damaged or modified soils: (1) seek the advice of an expert and do not rely on rule-of-thumb additions of amendments; (2) consider replacing poor soil with a high-quality topsoil or using engineered soil mixes such as a structural or other designed soil under newly constructed or replaced sidewalks and patios; (3) use proper mulching (e.g., 2 to 3 inches of a coarse-ground, well-cured, composted mulch kept away from the tree trunk) and mulch management to provide for vertical amendment of the soil over time. Remember that too much mulch, or mulch that has been compacted by foot or other traffic can actually impede water and air percolation and movement and cause dry, unhealthy growing conditions.



*Do not cover cement and other debris with a few inches of topsoil. All garbage and construction gravel should have been removed from these parking lot and other planting cutouts. These and other planters should be filled with topsoil or a professionally designed soil.*



## Amending Damaged Soils

When amending compacted planting areas before planting, well-cured composted organic material (mushroom compost, leaves, grass clippings, wood chips) should be incorporated at 25 to 30 percent of the total soil volume of the upper 6 inches or so of the entire planting area (not just the planting hole). Because of high pH and other considerations, well-cured composted sewage sludge is satisfactory but should not be used for more than 25 percent of total soil volume. Additions of composted municipal yard waste can help offset some occurrences of high ammonia content within these biosolids. The composted material must be thoroughly mixed with the native soil and amended together. This includes cultivating soils together at the bottom and sides of the planting area. Abrupt transitions and differences in soils can inhibit water movement and root growth and spread.

## Finding out the Problems

When planting trees and other plants in developed landscapes, a shovel, your hand, and a soil test are your best tools to understand the characteristics and capacities of the soil you are using. Dig a small hole to investigate structure, garbage, depth, compaction, and drainage. Squeeze dampened soil between your thumb and fingers to investigate texture. If compaction and drainage are concerns, pour a gallon of water into a 12-inch-wide, 24-inch-deep hole dug with a shovel. If the water does not drain from the hole in eight hours, consider planting in another location. Replacing, cultivating, or amending soil in areas with poor drainage may or may not help drainage, depending on the underlying cause of the problem, such as hardpans, old parking lots, and rock formations. Plantings in these areas may have to be engineered for drainage (e.g., French, PVC, or other drains), planted in mounded beds, or be provided some other special type of planting. Always use a soil test to find out about soil texture, fertility, pollution, and pH. These tests, and the directions for their use, are available through county extension offices.

## Final Strategies for Dealing with Construction-Damaged Soils

There are some recommended strategies for planting trees where construction or other activities have altered and damaged soils. Use a shovel and a soil test to find out about compaction, drainage, pH, and other important soil characteristics.

- Plant the easy places first. Plant trees in a front yard rather than a sidewalk cutout or small tree lawn.

- Design and construct bigger planting spaces and make space for roots. Increase the areas of available topsoil and reduce the amount of soil compaction required by designing and constructing large cutouts (5 by 5 by 3 to 6 by 6 by 3 feet minimum). Design tree lawns that are at least 6 feet wide and use structural or other designed soils, continuous planters that run parallel to the curb, and properly designed parking lot planters. Larger cutouts or continuous planters (e.g., to accommodate the growth of two large trees, a cutout/planter 24 feet long, 5 feet wide, and 3 feet deep should be constructed) have been used in Philadelphia and other cities to plant trees in downtown sidewalk areas.

- Preserve and use existing soils. If the soil in which you are planting has a decent texture and is fertile, softly break existing compaction and reuse.
- Improve soil and drainage. Break compaction, amend or replace poor soils, and maintain or create drainage using French drains, plastic piping, or other means.
- Select the right type of tree. Put the right tree in the right place and make the place right for the tree.

## Some Important Soil Terms

**Alkaline soil**—any soil that has a pH value greater than 7.

**Bulk density**—the mass of a dried soil per unit bulk volume. A measure of compaction.

**Compaction (also called layering)**—results when machinery or other pressure breaks soil structure and increases its bulk density. Structure is crushed and disintegrates, causing the collapse of large pore spaces essential for rapid water, air, and root movement.

**Fertility**—the status of a soil with respect to the amount and availability to plants of nutrients necessary for growth.

**Friable**—a term pertaining to the ease of crumbling of soils.

**Hardpan**—a hardened soil layer in the lower A or in the B horizon caused by the cementation of soil particles with organic matter or with materials such as calcium carbonate. Hardpans are also caused by rock formations, old parking lots and street sections, and underlying layers of soil that have been compacted.

**Infiltration**—the downward entry of water into a soil.



*For the best results, innovative designs that provide for more fertile soil, rooting areas, and storm water management should be used.*

**Parent material**—the weathered geological material from which topsoil and subsoil have been derived.

**Percolation**—the downward movement of water through a soil. Unless saturated with water, sandy soils will have much higher infiltration and percolation rates than clay or compacted soils. But clay soils have higher nutrient-holding and provision traits than sandy soils.

**Permeability**—the ease with which gases, liquids, or plant roots penetrate or pass through a mass of soil.

**pH**—the degree of acidity (lower pH) or alkalinity (higher pH) of a soil. Most plant materials prefer slightly acidic pH. Neutral is a pH value very close to 7.0; slightly acidic is 6.6–6.0; slightly alkaline is 7.4–8.0; strongly acidic is 5.0–4.0; strongly alkaline is 9.0–10.0; very strongly acidic is 4.0–3.0; and very strongly alkaline is 10.0–11.0.

**Surface or topsoil**—the top portion of the soil usually moved in cultivation. The top 3 to 10 inches of the soil is presumed to be fertile. A desirable topsoil should contain about 45 percent mineral material, 50 percent pore space, and 5 percent organic material.

**Saturation**—to fill all the voids or pores between soil particles with a liquid. Soils saturated for longer periods can have poor aeration and high levels of CO<sub>2</sub>, both detrimental to root respiration and growth.

## Resources

Brady, Nyle C., and Raymond Weil. *The Nature and Properties of Soils. 14th ed.* Upper Saddle River, N.J.: Prentice Hall, 2007.

Craul, Phillip J. *Urban Soils: Applications and Practices.* New York: John Wiley and Sons, 1999.

Craul, Timothy A., and Phillip J. Craul. *Soil Design Protocols for Landscape Architects and Contractors.* New York: John Wiley and Sons, 2006.

Elmendorf, William. *Planting and After Care of Community Trees.* University Park: The Pennsylvania State University, 2001.

Elmendorf, William. *A Guide to Preserving Trees in Development Projects.* University Park: The Pennsylvania State University, 2005.

Ramsey, Charles G., and John R. Hoke. *Architectural Graphic Standards.* New York: John Wiley and Sons, 2000.

Sjoerd W. Duiker. *Diagnosing Soil Compaction Using a Penetrometer.* University Park: The Pennsylvania State University, 2002.

Prepared by Bill Elmendorf, assistant professor of urban and community forestry.

## AUTHOR'S NOTE:

Thanks to the University of California for the drawn illustrations used in this publication.

Visit Penn State's College of Agricultural Sciences on the Web: [www.cas.psu.edu](http://www.cas.psu.edu), Penn State College of Agricultural Sciences research, extension, and resident education programs are funded in part by Pennsylvania counties, the Commonwealth of Pennsylvania, and the U.S. Department of Agriculture.

This publication is available from the Publications Distribution Center, The Pennsylvania State University, 112 Agricultural Administration Building, University Park, PA 16802. For information telephone 814-865-6713.

This publication is available in alternative media on request.

The Pennsylvania State University is committed to the policy that all persons shall have equal access to programs, facilities, admission, and employment without regard to personal characteristics not related to ability, performance, or qualifications as determined by University policy or by state or federal authorities. It is the policy of the University to maintain an academic and work environment free of discrimination, including harassment. The Pennsylvania State University prohibits discrimination and harassment against any person because of age, ancestry, color, disability or handicap, national origin, race, religious creed, sex, sexual orientation, gender identity, or veteran status. Discrimination or harassment against faculty, staff, or students will not be tolerated at The Pennsylvania State University. Direct all inquiries regarding the nondiscrimination policy to the Affirmative Action Director, The Pennsylvania State University, 328 Boucke Building, University Park, PA 16802-5901; Tel 814-865-700/V, 814-863-1150/TTY.

Produced by Ag Communications and Marketing

© The Pennsylvania State University 2008

Code # **UH187**      4M2/08mpc4852



### **Erosion and Sediment Control Best Management Practices For Water Well Drilling and Aquifer Testing**

This fact sheet describes Best Management Practices that should be used in developing and implementing erosion and sediment (E&S) control plans at water well drilling and aquifer testing sites. Because site conditions vary greatly, it is recommended that all well drilling contractors meet with county conservation district staff prior to beginning the work to discuss site constraints and the most appropriate plan.

#### **Erosion and Sediment Control Measures for Residential Wells and Other Low Capacity Wells**

The installation of most residential wells typically involves the generation of **up to 25 gallons per minute (gpm)** including both the drilling operation and the pumping operation. The recommended E&S control measures to address the low flows leaving the well casing involve limited detention and then discharge from the well area overland through vegetated terrain.

Detention time should be provided to cause the well cuttings and solids to drop out of the flow. For wells being drilled at construction sites, this can be accomplished by excavating a shallow trench, 10 to 15 feet long, immediately downgrade of the well. The downstream edge of the trench should be level to allow water to spill out uniformly over the entire length of the trench. A semi-circle of silt fence or straw bales should be installed downgrade of the trench for further sediment removal. Refer to Tables 17 and 18 of the *Erosion and Sediment Pollution Control Manual* DEP ID: 363-2134-008 (E&S Manual) on DEP's Web site at [www.depweb.state.pa.us](http://www.depweb.state.pa.us), keyword: Source Water and Groundwater Protection.

From the trench, overland flow should be directed as sheet flow across a thickly vegetated area. This vegetated filter must conform to slope requirements discussed for vegetative filter strips in the E&S Manual. As indicated, a minimum of 50 feet of vegetated terrain must be available between the trench and the nearest down slope water conveyance. If adequate vegetation is not available downgrade of the well site, or if the minimum distance to water conveyance is less than 50 feet, E&S measures for medium and high capacity wells described below should be employed. These more rigorous E&S measures for medium and high capacity wells should also be used for all residential or small sized wells drilled within 200 feet of high quality and exceptional value waters as defined in Pa. Code Chapter 93.

For wells being installed in established, landscaped areas, minimal site disturbance is desirable. An alternative to the trench described above is to use a device on the well casing to divert drillings to a tank truck or a container which can be hauled from the site for disposal.

#### **Erosion and Sediment Control Measures for Medium and High Capacity Wells**

More rigorous E&S measures are recommended for medium and high capacity wells with anticipated flows **exceeding 25 gpm**. Most larger private wells and public water supply wells will exceed these low flows.

The recommended E&S measures to address the medium to high flows leaving the well casing involve detention in an excavated sump and pumping the settled water through a filter bag.

Adequate detention time can be provided by directing well casing overflow to an excavated sump sized so that the volume of the sump in cubic feet is equal to the flow in gallons per minute. Settled water from the sump is pumped to an appropriately sized filter bag. According to manufacturer's recommendations, the filter bag should be placed on a stabilized area of dense vegetation as shown in Standard Construction Detail #26 (E&S Manual). If the vegetative cover is not available, the filter bag should be placed on a bed of gravel.

#### **Erosion and Sediment Control Measures for Aquifer Testing**

Flows exceeding 500 gpm are possible during aquifer testing of some water supply wells. The clarity of the test flows may vary from very muddy in a limestone aquifer where clay is present, to quite clear in a sandstone aquifer. Measures must be taken to prevent sediment pollution from aquifer tests with turbid water. Precautions are also needed to allow high flows of clear water to discharge from the site without causing accelerated erosion of the landscape.

Muddy water yielded by aquifer testing should be allowed to settle and then pumped through a filter bag as described above in E&S Control Measures for Medium and High Capacity Wells. Considering that these flows can be very high, the contractor must utilize large enough filter bags or construct a manifold system using several

smaller bags at one time. Care should also be taken to replace the bags promptly when full or when they fail due to a tear in the material.

In a situation where the actual well yields exceed anticipated flows by a considerable amount and the erosion and sediment control measures are inadequately sized, and waterways are threatened with sediment pollution, the operation must be shut down until more appropriate E&S controls are provided. It is recommended that the county conservation district or DEP Regional Office be contacted to assist in developing the appropriate E&S controls.

Clear water flows generated during well yield pumping should be discharged to a watercourse by way of a diversion channel or conduit. The project's E&S plan should provide details on proposed means of transporting the clear water. A typical cross section and design considerations for a clear water diversion channel are provided in Standard Worksheet #22 in the E&S Manual. The channel lining must be designed appropriately for the anticipated velocity. In a similar manner, if a conduit is proposed, supporting hydraulic design information should be provided.

Adequate protection against erosion should be placed at the downstream end of the clear water diversion channel or conduit. A General Permit No. 3 may be required for the protection and a General Permit No. 4 may be required for the outfall, depending on the drainage area of the receiving stream at the discharge point.

It is important to remember that when considering the most appropriate means of controlling erosion and sediment at well sites, recirculating the discharge water into the aquifer will invalidate the aquifer test. Therefore, care must be taken in designing and locating the E&S control measures so that the aquifer test does not induce artificial recharge from discharged well water.

### Summary

The preceding E&S measures are considered acceptable Best Management Practices for well drilling sites. However, site constraints may require that other measures be taken to prevent erosion and sediment pollution. Alternatives to these measures can be developed and agreed upon by the well driller and the conservation district where appropriate.

For more information, visit [www.depweb.state.pa.us](http://www.depweb.state.pa.us), keyword: Source Water and Groundwater Protection.

For more information, call the county conservation district or the DEP regional office in your area or contact:

**Department of Environmental Protection  
Bureau of Watershed Management  
P.O. Box 8555  
Harrisburg, PA 17105-8555  
717-787-9633**

**Department of Environmental Protection  
Bureau of Water Standards and Facility Regulation  
P.O. Box 8774  
Harrisburg, PA 17105-8774  
717-787-8184**

#### Southeast Region

2 E. Main St.  
Norristown, PA 19401  
Main Telephone: 484-250-5900  
24-Hour Emergency: 484-250-5900

**Counties:** Bucks, Chester, Delaware, Montgomery and Philadelphia

#### Southwest Region

400 Waterfront Drive  
Pittsburgh, PA 15222-4745  
Main Telephone: 412-442-4000  
24-Hour Emergency: 412-442-4000

**Counties:** Allegheny, Armstrong, Beaver, Cambria, Fayette, Greene, Indiana, Somerset, Washington and Westmoreland

#### Southcentral Region

909 Elmerton Ave.  
Harrisburg, PA 17110  
Main Telephone: 717-705-4700  
24-Hour Emergency: 1-877-333-1904

**Counties:** Adams, Bedford, Berks, Blair, Cumberland, Dauphin, Franklin, Fulton, Huntingdon, Juniata, Lancaster, Lebanon, Mifflin, Perry and York

#### Northwest Region

230 Chestnut St.  
Meadville, PA 16335-3481  
Main Telephone: 814-332-6945  
24-Hour Emergency: 1-800-373-3398

**Counties:** Butler, Clarion, Crawford, Elk, Erie, Forest, Jefferson, Lawrence, McKean, Mercer, Venango and Warren

#### Northeast Region

2 Public Square  
Wilkes-Barre, PA 18711-0790  
Main Telephone: 570-826-2511  
24-Hour Emergency: 570-826-2511

**Counties:** Carbon, Lackawanna, Lehigh, Luzerne, Monroe, Northampton, Pike, Schuylkill, Susquehanna, Wayne and Wyoming

#### Northcentral Region

208 W. Third St., Suite 101  
Williamsport, PA 17701  
Main Telephone: 570-327-3636  
24-Hour Emergency: 570-327-3636

**Counties:** Bradford, Cameron, Centre, Clearfield, Clinton, Columbia, Lycoming, Montour, Northumberland, Potter, Snyder, Sullivan, Tioga and Union

## APPENDIX L – GLOSSARY

**NOTE – This glossary is intended to be a comprehensive directory for industry terms for plan preparers and reviewers. Therefore, many terms found in this glossary are not included in the manual.**

# A

- A** ----- Symbol for Area. In Runoff Calculations, it stands for Tributary Drainage Area to the BMP being designed; in Channel Calculations, it represents the cross-sectional area of the channel, likewise for Culvert Calculations it is the cross-sectional area of the Culvert. In Basin Dewatering Calculations, it stands for the area of the riser perforations.
- A-Horizon** -----The uppermost zone in the Soil Profile, from which soluble Salts and Colloids are leached, and in which organic matter has accumulated. It generally represents the most fertile soil layer.
- AASHTO** -----American Association of State Highway and Transportation Officials.
- AASHTO # 1 Stone** -----A standard size range for Coarse Aggregate Stone ranging from ¾” to 4” in diameter. (See Table 6.7)
- AASHTO #57 Stone** -----The standard size range for Coarse Aggregate Stone ranging from that which passes a #8 Sieve to 1 ½” in diameter. (See Table 6.7)
- ABACT** -----Antidegradation best available combination of technologies
- Abatement** -----Reducing the degree or intensity of, or eliminating, pollution.
- Abrasion** -----Removal of stream bank soil as a result of sediment-laden water, ice, or debris rubbing against the bank.
- Absorption** -----The process by which a liquid is drawn into and tends to fill permeable pores in a porous body.
- Abutment** -----1. A retaining wall that also supports a vertical load (e.g. a bridge abutment). 2. In dams, it is the part of a valley sidewall against which a dam is constructed.
- Abutting** -----In real estate, the property adjoining or bordering another property.
- Accelerated Erosion** -----Erosion of surface materials due to human activities at a rate that is faster than would occur naturally. (See Introduction)
- Access Road** -----A roadway, either temporary or permanent, constructed for the purpose of accessing a structure, facility, or BMP.
- Acid** -----A substance that releases hydrogen ions when dissolved in water. A strong acid will release a large proportion of ions while a weak acid will release a small proportion of ions.
- Acid Mine Drainage (AMD)** -----A term indicating a discharge composed of leachate from a mine, usually a surface or underground coal mine, typically characterized by low pH, high iron and sulfate content, and high dissolved solids.
- Acid Producing Materials** -----Rock containing significant concentrations of pyrite, such that if exposed to air and/or water will produce sulfuric acid.
- Acid Soil** -----Soil with a pH below 7.0.
- Acre** -----A measure of area equal to 43,560 square feet (4,046.87 square meters). One square mile equals 640 acres.
- Acre-Foot (AF)** -----A unit commonly used for measuring the volume of water. It is equal to the quantity of water required to cover one acre to a depth of 1 foot. It is equivalent to 43,560 cubic feet (1,234 cubic meters) or 325,851 gallons.
- Act 167** -----The Pennsylvania Stormwater Management Act, 32 P.S. §§ 680.1— 680.17. It provides for the regulation of land and water use for flood control and storm water management purposes, imposing duties and conferring powers on the DEP, municipalities and counties, providing for enforcement, and making appropriations.
- Adjudication** -----A court proceeding to determine water rights for a particular stream or aquifer.
- Adsorption** -----The physical adherence or bonding of ions and molecules to the surface of another molecule. The preferred process used in cleanup of environmental spills.
- Aerated Concrete** -----Lighter weight concrete; it has bubbles incorporated into the mix to make it so.



**Aeration** -----Mixing water with air.

**Aerial Photo** -----Photograph taken from an airplane.

**Aerial Survey** -----Survey taken from aerial photos.

**Aerification** -----A mechanical process used to cultivate the soil without destruction of the turf.

**Aerobic** -----Requiring oxygen (e.g. bacteria that function in the presence of free dissolved oxygen).

**AF** -----Acre-feet.

**Ag Lime** -----Crushed limestone, used to raise the pH of acid soils.

**Agency Programmatic Permits** -----Chapter 105 permits issued to certain Commonwealth agencies for maintenance activities located in or along various streams within the Commonwealth.

**Agent** -----Anyone who has the authority to act on the behalf of another, representing the business interests of that person.

**Agglomeration** -----The uniting of dispersed suspended matter into larger flocs or particles that settle rapidly.

**Aggradation** -----The excessive accumulation of sediment that results in raising streambed elevation.

**Aggregate** -----Hard, tough, durable, particles, reasonably free from silt, clay, and vegetation. Coarse aggregates — those retained on a No. 4 sieve — are often used as filter stone.

**Aggregate, Coarse** -----Aggregates ¼” diameter or larger. (See Table 6.6)

**Aggregate, Fine** -----Those passing a No. 4 sieve but retained on a No. 200 sieve. (See Table 6.6)

**Aggregate, Lightweight** -----Aggregate having a dry density of 70 lb/ft<sup>3</sup> or less.

**Agreement of Sale** -----Document detailing the terms and sale price of a transaction, along with a description of the property and any time limits.

**Agricultural Crossing** -----A stream crossing installed for purposes of gaining access to a field or orchard for agricultural operations. A GP-6 is required.

**Agricultural Extension Service** -----A state agency responsible for soil and water conservation information and education.

**Agricultural Land Use** -----Cropland, pasture, orchards, vineyards, nurseries, horticulture areas, confined animal feeding operation, fallow fields, reverting cropland or pasture/field (can include scrub shrub land).

**Agricultural Limestone** -----Ground limestone containing sufficient calcium and magnesium carbonate to be equivalent to not less than 80 percent calcium carbonate and fine enough to pass not less than 90 percent through a U.S. Standard No. 10 sieve and not less than 35 percent through a No. 50 sieve.

**Agricultural Operation** -----The management and use of farming resources for production of crops, livestock, or poultry, or for equine activity.

**Agricultural Plowing or Tilling** -----1. Earth disturbance activity involving the preparation and maintenance of soil for the production of agricultural crops. 2. The term includes no-till cropping methods which are the practice of planting crops with minimal mechanical tillage.

**Agricultural Property** -----Land zoned for use in farming, including raising of crops and livestock.

**Agricultural Ramp** -----The stabilization of a stream bank with stone or timber to provide protection of the stream bank from livestock and agricultural equipment use.

**Algae** -----Simple photosynthetic plants having neither roots, stems, nor leaves.

**Algal Bloom** -----1. Rapid growth of algae on the surface of lakes, streams, or ponds; stimulated by nutrient enrichment. 2. A heavy growth of algae in and on a body of water as a result of high phosphate concentration such as from fertilizers and detergents. It is associated with Eutrophication and results in a deterioration in water quality.

**Alidade** -----Upper part of a transit or telescopic instrument used to take bearings.

**Alkaline Soil** -----Soil with a pH above 7.0.

**Alkalinity** -----The ability of a substance to neutralize an acid.

**Along** -----Touching or contiguous; to be in contact with; to abut upon.

**Allowable Fish Passage Velocity** -----The maximum velocity fish can tolerate when passing upstream through a culvert.

**Allowable Headwater Elevation** -----The maximum permissible elevation of the headwater at a culvert at the design discharge.

**Alluvial Deposit** -----Material deposited by a stream or other body of running water.

**Alluvial Soil** -----Soil developed from transported and relatively recently deposited material (alluvium).

**Alluvium** -----Deposits of clay, silt, sand, gravel, or other particulate material that has been deposited by a stream or other body of running water.

**Alum** -----A common name for aluminum sulfate, used as a coagulant.

**Ambient Water Quality** -----The quality of water that would be expected to exist in the absence of human activities. It is usually determined from quality measurements of waters that are not affected by waste discharges or other human activity.

**Anabranch** -----One of a series of intertwining channels in a braided stream.

**Anaerobic** -----Not requiring free oxygen (e.g. bacteria that function in the absence of dissolved free oxygen).

**Anchor** -----A series of methods used to secure a structure to its footings or foundation wall so that it will not be displaced by water, wind, or gravity.

**Anchor Trench** -----A shallow excavation made along the alignment of a sediment barrier for purposes of burying the bottom of the filter fabric, filter log, or straw bales. The purpose is to prevent undercutting of the barrier by runoff impounded by the barrier.

**Angle Dozing** -----Movement of earth with a blade set at an angle that allows the earth to be moved forward and off to one side.

**Angle of Repose** -----The maximum angle, as measured from the horizontal, at which granular particles can stand.

**Animal Heavy Use Area** -----Barnyard, feedlot, loafing area, exercise lot, or other similar area on an agricultural operation where due to the concentration of animals it is not possible to establish and maintain vegetative cover of a density capable of minimizing accelerated erosion and sedimentation by usual planting methods. This term does not include entrances, pathways and walkways between areas where animals are housed or kept in concentration.

**Antecedent Moisture** -----The degree of wetness of soil at the beginning of a runoff, determined by summation of weighted daily rainfall amounts for a period preceding the runoff.

**Anticipated Flow Depth** -----The calculated flow depth required for a given channel or pipe to convey a design discharge.

**Anticipated Velocity** -----The calculated velocity required for a design discharge to pass through a given channel or pipe.

**Antidegradation Analysis** -----A required evaluation of the anticipated impact of a proposed earth disturbance activity upon a receiving water that has an existing or designated use of HQ or EV.

**Antidegradation Best Available Combination of Technologies (ABACT)** ----- Environmentally sound and cost effective treatment, land disposal, pollution prevention and stormwater reuse BMPs that individually or collectively manage the difference in the net change in stormwater volume, rate and quality for the storm events up to and including the 2-year/24-hour storm when compared to the stormwater rate, volume and quality prior to the earth disturbance activities to maintain and protect the existing quality of the receiving surface waters of this Commonwealth.

**Anti-scour Protection Apron** -----An apron in front of a revetment to help protect the revetment against underscour.

**Anti-seep Collar** -----A plate made of metal, plastic, concrete, or otherwise non-degradable material placed around the outlet barrel of a basin, pond, or trap in such a way that it increases the flow path of water seeping through the embankment sufficiently so as to minimize the potential for piping. All connections must be watertight.

**Anti-vortex Device** -----A metal plate placed vertically into the top of the Principal Spillway Riser of a Sediment Basin or Trap to prevent swirling of water entering the top of the riser so as to ensure that the design capacity of the riser is provided.

**Appurtenance** -----Interrelated elements or components of a designed system or structure.

**Appurtenant Structures** -----Features that are designed to complement something else (e.g. an outlet or spillway of a dam).

**Apron** -----A covering along a shoreline or immediately below a pipe or channel outfall for protection against erosion.

**Approved** -----Term used to indicate that a particular plan or part thereof has been determined to be in compliance with the appropriate regulations. It does not indicate that it is the most efficient or cost-effective method of operation.

**Aquiclude** -----A geologic formation with insufficient permeability to allow for significant passage of water.

**Aquifer** -----A saturated or partially saturated geologic formation with sufficient permeability to hold and transmit water in quantities suitable for an intended use.

**Aquitard** -----A geologic formation without sufficient permeability to permit sufficient groundwater flow to meet an intended use.

**Arable** -----Land suitable for growing crops.

**Archaeological Field investigation** -----Extensive controlled excavation of an archaeological site to study the cultural history using professionally accepted means of sampling, removing and excavating archaeological specimens, also known as phase three archaeological research or data recovery.

**Archaeological Survey** -----A visual inspection and limited sampling and excavation of an archaeological site to determine the characteristics and physical extent of a site, also known as phase one or phase two archaeological research.

**Armor** -----A protective covering for an area that is otherwise exposed to erosion.

**Army Corps of Engineers (ACOE)** -----A federal agency that in its civilian role, plans and executes national programs for navigation and commerce, flood control, water supply, hydroelectric power generation, recreation, conservation, and preservation of the environment.

**Artesian Aquifer** -----A confined aquifer with a piezometric height greater than the height of the aquifer.

**Artesian Spring** -----Water from an artesian aquifer which flows to the surface naturally.

**Artesian Well** -----Any well this taps into an artesian aquifer, even if the water surface does not reach the top of the well.

**Articulated Concrete Block Revetment System** ----- A matrix of individual concrete blocks placed together to form an erosion resistant overlay that meets specific design parameters.

**Articulated Concrete Mattress** -----Rigid concrete slabs, which can move as scour occurs without separating, usually hinged together with corrosion-resistant wire fasteners; primarily placed for lower bank protection.

**Articulation** -----The state of being jointed or interrelated; a joint or juncture between parts or structures.

**Artificial Recharge** -----The practice of increasing, by artificial means, the amount of water that enters a ground water reservoir.

**As-Built (Record Drawing)** -----Drawing or certification (with a P.E. seal) of structures as they were actually constructed

**ASCE** -----American Society of Civil Engineers.

**Asphalt Emulsion** -----A mixture of asphalt cement with water. The asphalt sets when the water evaporates.

**Assimilation** -----The ability of a body of water to purify itself of pollutants.

**ASTM** -----American Society for Testing Materials.

**Attenuation** -----1. Reduction in magnitude, as in the lowering of peak runoff discharge rates, in the case of dry ponds. 2. Reduction of contaminant concentrations, as in the action of biodegradation in wetlands or bioretention facilities.

**Auxiliary Spillway** -----A spillway whose control section is at a lower elevation than the emergency spillway and higher than the principal spillway.

**Available Soil Moisture** -----That portion of moisture in soils that can be readily absorbed by plant roots.

## B

**b** -----The symbol of Bottom Width in Channel Calculations.

**B-Horizon** -----The lower soil zone that is enriched by the deposition or precipitation of material from the overlying A-Horizon.

**Back Blade** -----The process whereby a bulldozer or grader with its blade in the down position moves backward in order to smooth out a soil surface.

**Backfill** -----The process of filling an excavated hole with soil, gravel, rock, or other material.

**Backflow** -----The backing up of water through a conduit or channel in the direction opposite to normal flow.

**Backhoe** -----Heavy equipment used in construction, which has a bucket suspended on a movable boom.

**Backshore** -----The zone of a shore or beach including the berms that lie between the foreshore and the dunes or bluffs. The backshore is acted upon by waves only during severe storm events, especially when combined with exceptionally high water.

**Backslope** -----The downstream slope of an embankment.

**Backwater** -----The area upstream of a water obstruction that would be flooded because of the obstruction.

**Backwater Area** -----1. The low-lying lands adjacent to a stream that become flooded during periods of high water.

**Baffle** -----A wall installed across the bottom of a Sediment Basin or Trap for the purpose of increasing the length of the flow path of water through the impoundment from the point where it enters the impoundment to the principal spillway. (See Standard Construction Detail #7-14)

**Ballast** -----1. Stone or gravel that provides drainage and stability as a base for concrete. 2. In railroads, gravel-sized material, normally an aggregate, on which the railroad ties are placed.

**Bank** -----The part of the soil adjacent to a stream, lake, or body of water, having an elevation higher than the normal water level.

**Bank Migration** -----Lateral or horizontal migration of the banks of a stream channel.

**Bank Rehabilitation and Bank Protection** -----To restore and/or protect the bank of a stream, lake, pond, or reservoir against erosion, scour, or sloughing by using any of the following: slope protection, dumped rock protection, cribbing, walls, channel deflectors, vegetative stabilization techniques.

**Bank Slip** -----Downward movement of the bank of a stream or body of water caused by erosion and/or stress.

**Bankfull Discharge (Bankfull Flow)** -----The stream flow that transports the majority of a stream's sediment load over time and thereby forms the channel; the discharge that fills a stable alluvial channel to the elevation of the active floodplain; bankfull discharge is the basis for measuring width/depth ratio and entrenchment ratio.

**Bar** -----A sand or gravel deposit in a streambed that is often exposed only during low water periods.

**Barrel** -----The outlet pipe running through the embankment of a Sediment Basin or Trap. (See Standard Construction Detail #8-2)

**Barren Land Use** -----Beaches; sandy areas other than beaches; bare exposed rock, such as bedrock, talus or fill; surface mines; quarries; and transitional zones, such as areas previously bare but becoming vegetated.

**Base Course** -----The bottom portion of a pavement where the top and bottom portions are not the same composition.

**Base Flow** -----The normal flow in a channel or swale not in response to a recent storm. This flow is supported by groundwater seepage into the channel.

**Base Flow Recession** -----The declining rate of discharge of a stream fed only by base flow for an extended period of time. Typically, a base flow recession will be exponential.

**Basin** -----An impoundment area constructed to contain and slow runoff to permit the settling and collection of sediment transported by runoff.

**BAT** -----Best available technology.

**Batch Plant** -----Production plant for large quantities of concrete.

**Bearing Capacity** -----The maximum load that a material (e.g. soil) can support before failing.

**Bed** -----The bottom of a stream or channel.

**Bed Load** -----Sediment (up to rock) that is transported in a stream by rolling, sliding, or skipping along or very close to the channel bottom.

**Bed Slope** -----The gradient of a channel. It is determined by dividing the difference in elevation — upper end to lower end of reach — by the channel length.

**Bedform** -----A relief feature on the bed of a stream, such as dunes, plane bed or antidunes. Also called bed configuration.

**Bedrock**----- The more or less solid rock in place either on the surface or under the soil layers. It may be soft, medium or hard and have a smooth or irregular surface.

**Bench** -----A constructed break in a cut slope or fill slope for the purpose of conveying runoff to one or both sides.

**Bench Mark** -----Point of known elevation for a survey. It may be in relation to National Geodetic Vertical Datum (NGVD) or assumed for a given project.

**Benthic Zone** -----The bottom zone of a lake, where oxygen levels are low.

**Bentonite** -----A volcanic clay material that exhibits extremely large volume changes with moisture content changes, filling gaps and sealing itself against adjacent materials. It is commonly used to seal abandoned wells or leaking spillways in sediment basins and traps.

**Berm** -----1. A compacted mound or wall of earth used to direct runoff (e.g. dike) or impound it (e.g. embankment of a sediment basin or trap). 2. A nearly horizontal part of a beach or backshore formed at the high water line by waves depositing material. Some beaches have no berms, others have one or several.

**Best Management Practice (BMP)** ----- Activities, facilities, measures, planning or procedures used to minimize accelerated erosion and sedimentation and manage stormwater to protect, maintain, reclaim, and restore the quality of waters and the existing and designated uses of waters within this Commonwealth before, during, and after earth disturbance activities.

**Beveled End** -----A type of endwall with a cut that is inclined to the horizontal.

**Biennial Plant** -----A plant that requires 2 years to complete its life cycle.

**Bifurcation Ratio** -----The average number of streams feeding into the next order waterway. The usual range is 2 to 4.

**Binder** -----1. A natural or synthetic additive that causes an otherwise non-cohesive material to become bound into a cohesive matrix; 2. emulsion or tackifier.

**Biochemical Oxygen Demand (BOD)** -----The quantity of oxygen needed by microorganisms in a body of water to decompose the organic matter present. An index of water pollution.

**Biodegradable** -----Able to decompose when exposed to biological agents and/or soil chemicals.

**Bioengineering** -----1. Use of woody vegetative growth to stabilize stream banks and other slopes. 2. Combination of vegetative and structural practices to stabilize stream banks and/or slopes.

**Biofiltration** -----The simultaneous process of filtration, infiltration, adsorption, and biological uptake of pollutants in stormwater that takes place when runoff flows over and through vegetated areas.

**Blanket** -----Material placed on exposed soil to hold it in place until a vegetative cover can be established.

**Bloom** -----A phenomenon whereby excessive nutrients within a body of water results in an explosion of plant life, resulting in a depletion of oxygen and fish kill, usually caused by runoff containing fertilizers.

**Bluff** -----A high, steep bank or cliff.

**BMPs** -----Best management practices

**BMP Fingerprinting** -----A series of techniques for locating BMPs, especially basins, within a development site so as to minimize their impacts to wetlands, forest, and sensitive stream reaches.

**BMP Sequence** -----See Construction Sequence

**Body of Water** -----Any natural or artificial lake, pond, reservoir, swamp, marsh or wetland.

**Bog** -----A type of wetland characterized by spongy, acidic peat deposits; a growth of evergreen trees and shrubs; and a carpet of sphagnum moss. Their only water source is rainwater and nutrient levels are very low. They often form in old glacial lakes.

**Boil** -----An upward disturbance in the surface layer of soil caused by water escaping under pressure from behind or under a water-retaining structure such as a dam or levee. The boil may be accompanied by deposition of soil particles, usually silt, in the form of a ring around the area where the water escapes.

**Borehole Log** -----A physical description of the various soil and/or rock types encountered while drilling a hole and the relative depths at which changes in soil or rock types occurred. If water is encountered during the drilling, the elevation(s) where this occurred are also noted.

**Boring** -----A hole advanced into the ground by means of a drilling rig.

**Boring, Test** -----Soil analysis taken by boring holes into the ground to remove samples.

**Borrow Area** -----Site where material is excavated for use as fill at another location; also known as a borrow site or borrow pit..

**Bottomlands** -----Lowlands adjacent to stream channels.

**Boulder** -----Rock fragment larger than 2 feet.

**Box Culvert** -----Drainage structure constructed from prefabricated, typically rectangular reinforced concrete, sections.

**Braided Stream** -----A shallow stream channel having many anabranches due to flow obstructions in a relatively wide flow path.

**Breach** -----A break-out or point of failure of a berm, channel, dike, or embankment.

**Breakwater** -----A structure protecting a shore area, harbor, anchorage, or basin from erosion due to wave action.

**Bridge** -----1. A structure and its appurtenant works erected over the regulated surface waters. 2. A single span structure erected from top of bank to top of bank carrying a roadway, walkway, railway, or other mode of transport over a stream.

**Broad-based Dip** -----A low point constructed on an access road or haul road for the purpose of diverting runoff from the roadway into a sediment removal facility or vegetative filter strip. (See Standard Construction Detail #s 3-6 and 3-7)

**Broadcast Seeding** -----A uniform distribution of seeds over an entire planted area.

**Brownfield** -----1. Land that is presently contaminated, is being remediated, or has been remediated under PA DEP's Land Recycling program. 2. Abandoned, idled, or under-used industrial and commercial facilities where expansion or redevelopment is complicated by real or perceived environmental contamination.

**Brownian Movement** -----The constant, random, zigzag movement of small particles dispersed in a fluid medium, caused by collision with molecules of the fluid.

**Brush Barrier** -----A sediment barrier constructed from compacted brush cleared from a right-of-way or work area. This practice has not been shown to be an effective BMP and is **NOT RECOMMENDED**.

**Brush Layering** -----Use of live branch cuttings, laid in crisscross fashion on benches between successive lifts of soil, to stabilize a stream bank or slope.

**Buffer** -----An area of vegetation immediately adjacent to a body of water, field, or cropland, used to protect it from sediment pollution, promote infiltration, and enhance wildlife habitat.

**Building Permit** -----Permit issued by a local government allowing construction or renovation of a house or other structure.

**Building Setback** -----Distance from a curb or property line that a building is located.

**Bulk Unit Weight** -----The weight of a material that fills 1 cubic foot.

**Bulkhead** -----1. A partition to retain or prevent sliding of soil, or to protect an upland area from damage due to wave action. 2. A sea wall, retaining wall, revetment, or armor.

**Bulldozer** -----Heavy construction equipment consisting of tractor-like machinery, which moves on treads, and has an adjustable front-mounted blade, which moves soil by pushing it in front of the machine.

**Bunchgrass** -----A grass that does not have rhizomes or stolons and forms a bunch or tuft.

**Buoyancy** -----Forces that cause a structure to float.

**Buoyant Weight** -----The downward force exerted by an object with a specific gravity greater than 1 when it is submerged in water.

**Burlap** -----Coarse material made from hemp or jute.

**Buttress** -----A projecting structure of masonry or wood for supporting or giving stability to a wall or building or structure; a projecting part of a mountain or hill; something that supports or strengthens.

**Bypass** -----A channel, pipe, or system used to convey base flow around a work area to a stable downstream discharge point.

# C

**C** -----Symbol for Runoff Coefficient in the Rational Equation.

**C-Horizon** -----A layer of unconsolidated material, relatively little affected by the influence of organisms and presumed to be similar in chemical, physical, and mineralogical composition to the material from which at least a portion of the overlying soil has developed.

**CADD** -----Computer Aided Design and Drafting, a graphics program used to design and animate systems and structures.

**Caisson** -----An air- and watertight chamber used as a foundation and/or support structure for excavating below water level; a concrete box-type structure.

**Candidate Species** -----Plant or animal species designated by the Department of the Interior, U.S. Fish and Wildlife Service (USFWS) as candidates for potential future listing as an Endangered Species or Threatened Species.

**Canopy** -----An overhanging cover formed by leaves, needles, and branches of vegetation.

**Cantilever** -----The part of a structure that extends beyond its support.

**Cap** -----A layer of material, such as clay or synthetic material, used to prevent rainwater from penetrating and spreading contaminated materials; the surface of the cap is typically mounded or sloped so water will drain off.

**Capillary water** -----Water just above the water table that is drawn up out of an aquifer due capillary action of the soil.

**Capture** -----1. Diversion of the flow of water in the upper part of a stream or watershed by the headward growth of another stream. 2. Diversion of runoff from one drainage area to another due to earthmoving activities or construction of stormwater systems.

**Cascade Flow** -----Regulated flow through a series of flow control structures.

**Cased Hole** -----An excavation whose sides are lined or sheeted.

**Casing** -----A liner inserted into a borehole or well to prevent collapse, seal off undesirable groundwater sources, and provide a convenient way to cap the well.

**Cast-in-Place** -----Pouring concrete in place, on-site instead of off-site as pre-cast material.

**Catch Basin** -----1. A chamber usually built at the curb line of a street, for the admission of surface water to a storm sewer or subdrain, having at its base a sediment sump designed to retain grit and detritus below the point of overflow. 2. A sieve-like device at the entrance to a storm sewer to stop debris that could possibly block up the sewer.

**Catchment** -----1. An area confined by drainage divides, usually having only one stream flow outlet; watershed. 2. A reservoir or other basin for catching water.

**Category I** -----A type of PASPGP-4 permit which does not require involvement by the ACOE.

**Category II** -----A type of PASPGP-4 permit which requires an opportunity for the ACOE to review and comment.

**Category III** -----A type of PASPGP-4 permit which requires review and approval by the ACOE.

**Causeway** -----A raised roadway constructed in or across a watercourse or wetland. (See Figure 3.8)

**Caving** -----1. The collapse of a stream bank due to undercutting, i.e. wearing away of the toe or an erodible soil layer above the toe. 2. The collapse of a trench due to unfavorable soil conditions and the lack of shoring.

**CCD** -----County conservation district.

**Cellular Block Mattress** -----Regularly cavitated interconnected concrete blocks placed directly on a streambank or filter to prevent erosion. The cavities can permit bank drainage and the growth of either volunteer or planted vegetation when synthetic filter fabric is not used between the mattress and bank.

**Cellular Concrete** -----Lightweight, low-density concrete that holds trapped air.

**Cellular Confinement System** ----- A honeycomb-like structure of cells, typically of geosynthetic material, that can be filled with a variety of materials to protect and stabilize a surface from the erosive effects of wind and/or water.

**Center-to-Center (CTC)** -----Measurement that goes from the centerline of one object to the centerline of another

**Central Office** -----1. The Rachel Carson State Office Building in Harrisburg; 2. DEP staff working out of the State Office in Harrisburg (Note: Some Central Office staff are located in other DEP offices around the state.)

**Central Sewage** -----A sewerage system consisting of pipes, lateral lines, trunk lines, or mains, which convey waste to a facility that provides treatment for final disposal. This term does not included

on-lot disposal, community on-lot disposal, or any other system that requires land surface of subsurface absorption area for treatment and disposal purposes.

**CERCLA** -----Federal Comprehensive, Environmental Response, Compensation, and Liability Act of 1980.

**CFM** -----Cubic Feet per Minute.

**CFR** -----Code of Federal Regulations. The compilation and codification of all current regulations that have been issued in final form by any federal regulatory agency and published in the Federal Register. Environmental regulations are covered under Title 40, Protection of the Environment.

**CFS, or cfs** -----Cubic Feet per Second. (Discharge Capacity)

**CG1** -----Control Guideline 1 in the Pennsylvania Stormwater Best Management Practices Manual.

**CG2** -----Control Guideline 2 in the Pennsylvania Stormwater Best Management Practices Manual.

**Chain Link Fence** -----Interlocking heavy lengths of wire stretched between metal poles.

**Channel** -----A watercourse or swale with a defined bed and bank, either natural or manmade.

**Channel Capacity** -----1. The maximum rate of flow that may occur in a channel without encroaching on the freeboard. 2. The maximum rate of flow that may occur in a stream channel without causing overbank flooding.

**Channel Erosion** ----- The erosion process whereby flowing water wears away the bed and/or banks of a stream channel.

**Channel Flow** -----In determining Travel Time ( $T_c$ ) for Runoff Calculations, it is the flow regime after Shallow Concentrated Flow.

**Channel-Forming Flow** -----See Stream-forming Flow.

**Channel Gradient** -----The slope of the channel bottom measured in drop per unit distance (e.g. feet per foot, ft/ft)

**Channel Hydraulics** -----A study of the movement of water through channels.

**Channel Lining** ----- The material applied to the bottom and/or sides of a natural or constructed channel to prevent or minimize abrasion, scour and other forms of erosion.

**Channel Reach** -----A section of a channel having the same or nearly the same flow conditions.

**Channel Realignment** -----Any alteration of the stream channel alignment which involves excavation into an existing stream bank.

**Channel Scour** -----The erosive action of water and sediment that removes and carries away bed and bank material.

**Channery Soil** -----Soil that is by volume more than 15% thin, flat fragments of sandstone, shale, slate, limestone, or schist as much as 6" along the longest axis.

**Chapter 92a** -----The Department's regulations about NPDES permits.

**Chapter 93** -----The Department's regulations regarding Water Quality Standards. The protected water uses of Pennsylvania's streams are identified in this chapter.

**Chapter 102** -----The Department's regulations concerning Erosion and Sediment Control.

**Chapter 105** -----The Department's regulations for Dam Safety, Waterway Management, Water Obstructions, and Encroachments.

**Check Dam** -----A flow barrier constructed across a channel or swale for the purpose of reducing gully erosion by reducing velocity, often placed in series. Adequate protection below the structure and around the sides is typically needed to prevent scour. **NOTE: This structure is not a recommended BMP for Erosion Control.**

**Check Valve** -----A valve that allows water to flow one direction but automatically closes when water attempts to flow the opposite direction.

**Choking of Flow** -----Severe backwater effect resulting from excessive constriction of a channel.

**Chrome** -----Intensity of color or purity.

**Chute** -----A usually permanent channel specially designed to convey water down a steep slope, such as where a collector channel enters a detention pond. It is typically protected with pavement or hard armor type lining.

**Cistern** -----Rainwater storage tank, sometimes underground.

**Clamshell** -----Soil excavation machinery with a bucket attachment that can be closed to hold in a load of soil and then opened to dump it.

**Clarification** -----The process of making water clear and free of suspended impurities.



**Clay** -----A fine-grained cohesive soil whose individual particles are not visible to the unaided eye (less than 0.002 mm dia.). It is typically plastic when wet — moist sample can be rolled into a 3 mm thick thread — and hardens when heated.

**Clay Liner** -----A layer of clay added to the bottom and sides of a basin or trap.

**Clayey Soil** -----Any soil having at least 20% clay content.

**Clay Stone** -----Rock consisting of hardened clay.

**Clean Fill** -----Uncontaminated, non-water soluble, non-decomposable, inert, solid material. This includes soil, rock, stone, dredged material, used asphalt, and brick, block or concrete from construction and demolition activities that is separate from other waste and is recognizable as such. It does not include materials placed in or on the surface waters unless otherwise authorized, milled asphalt, or asphalt that has been processed for re-use.

**Clean Streams Law (CAL)** -----(35 P.S. §§ 691.1—691.1001) Pennsylvania law passed in 1937 to preserve and improve the purity of the waters of the Commonwealth.

**Clean Water Act (CWA)** -----The federal Water Pollution Control Act (33 U.S.C.A. §§ 1251—1376) to regulate discharges to waters within the United States.

**Clearing** -----Removal of vegetative ground cover.

**Closed-conduit Flow** -----Flow in a pipe, culvert, etc. where there is a solid boundary on all sides.

**Clustering** -----Locating buildings in a development close together in order to minimize disturbance and reduce runoff.

**CMP Pipe** -----Corrugated Metal Pipe ( $n = 0.024$  to  $0.025$ ).

**CPN** -----Runoff curve number (TR-55).

**Coagulation** -----The process in which very small, finely divided solid particles, often colloidal in nature, are agglomerated into larger particles.

**Coarse Fragments** -----Mineral or rock fragments between 2 millimeters and 25 centimeters —0.08 and 10 inches — in diameter in soils.

**Coarse Textured Soil** -----Sand or loamy sand.

**Coast** -----The strip of land of indefinite width — up to several miles — that extends from the shoreline inland to the first major change in terrain features.

**Cobble** -----Rock fragment, usually rounded or semi-rounded, with an average dimension between 3” and 12”.

**COE** -----U. S. Army Corps of Engineers.

**Coefficient of Permeability** -----The rate of flow of a fluid through a unit cross-section of a porous mass under a unit hydraulic gradient usually measured in centimeters per second.

**Coefficient of Runoff (C)** -----See Runoff Coefficient.

**Cofferdam** -----A temporary dam installed within a body of water to prevent water from entering a work area. Such dams should be constructed from sand bags, Jersey barriers, or other non-erosive material, **NO EARTH FILL**. (See Figures 3.12 and 3.13, Standard Construction Detail # 3-15)

**Cohesionless Soil** -----A granular soil, such as gravel, sand, and no plastic silts.

**Cohesive Soil** -----A soil containing significant amounts of clay and silt such that the soil particles have a natural resistance to being pulled apart at their point of contact.

**Coir** -----Coconut fiber.

**Coir Log or Coir Roll** -----Roll of coconut fiber, often used in bioengineering systems to provide erosion control along a stream bank so as to support the establishment of vegetation.

**Coldwater Fish** -----A fish that requires relatively cool water for survival. While the optimum temperature varies by species, most are found in water where temperatures are 68° F (20° C) or less.

**Collector** -----A channel, dike or other conveyance, constructed downslope of an earth disturbance activity for the purpose of collecting stormwater runoff from that area and conveying it to facilities for sediment retention or removal.

**Collector Channel** -----A channel used to collect runoff from a disturbed area and convey it to a sediment removal facility, such as a sediment basin or trap.

**Colloidal Particles** -----Soil particles that are so small — typically 0.0001 to 1 micron in size — and so dispersed in water that they do not settle out, but not so fine and so dispersed as to be dissolved.

**Colluviums** -----Soil and rock that has moved or is moving down the face of a slope.

**Combined Sewer System (CSS)** -----A sewer system that carries both sanitary wastes and stormwater runoff. **Common Area** -----The area of a housing or condominium development that is owned by all residents.

**Common Area Assessments** -----Fees paid by a housing or condominium development, which are used to maintain, operate, or repair common areas.

**Compaction** -----Mechanically compressing soil into a dense mass.

**Complete Plan** -----An E&S Plan which addresses all eleven items required by Chapter 102.

**Complete Plan Checklist** -----The standard checklist that should be used to ensure that a submitted plan addresses all 15 items required by Chapter 102.

**Complex Slope** -----Irregular or variable slope.

**Compliance** -----Conducting earthmoving activities in such a way as to obey all applicable laws, rules, and regulations.

**Compost** -----Organic residue or a mixture of organic residues and soil, that has undergone biological decomposition until it has become relatively stable humus. (See Page 218)

**Compost Filter Berm**-----A sediment filter consisting of composted material blown into a berm configuration below a disturbed area for the purpose of filtering the runoff before exiting the site. (See Standard Construction Detail # 4-2)

**Compost Filter Sock** -----A mesh tube filled with composted material that is placed below a disturbed areas, perpendicular to sheet flow, to filter runoff before it leaves the site. (See Standard Construction Detail # 4-1)

**Concentrated Flow** -----Runoff which is not in the form of Sheet Flow.

**Concentration Time** -----See Time of Concentration.

**Concrete** -----A mixture of Portland cement, fine aggregate, coarse aggregate, and water.

**Concrete Rubble** -----Broken concrete in pieces not to exceed 5 feet in length where neither the width nor thickness is less than 1/3 its length and all reinforcing is removed flush with the face of the concrete.

**Conduit** -----Any channel or pipe intended for the conveyance of water, whether open or closed.

**Cone of Depression** -----The shape of a water table around a well during and immediately after use. The cone differs from the original water table by the amount of the well drawdown.

**Confined Aquifer** -----An aquifer overlain with an impervious layer, often under pressure.

**Confluence** -----The point at which 2 or more concentrated flows come together.

**Consent Agreement (CA)** -----A legal document that formalizes an agreement reached between the Department and a violator detailing the nature of the violations, the actions that will be taken to correct the violations and any penalties that will be paid by the violator.

**Conservation District** -----A conservation district, as defined in section 3(c) of the Conservation District Law (3 P.S. § 851(c)), which has the authority under a delegation agreement executed with the Department to administer and enforce all or a portion of the erosion, sediment, and stormwater management program in this Commonwealth.

**Conservation Easement** -----An agreement negotiated on privately owned land to preserve open space or protect certain natural resources.

**Conservation Plan** -----A plan that identifies conservation practices and includes site specific BMPs for agricultural plowing or Tilling Activities and animal heavy use areas.

**Conservation District Law** -----Act 217 of 1945, creating the Tate Conservation Commission and providing for the organization of the various counties into conservation districts.

**Consolidation** -----Densification of soil by mechanical means, involving expulsion of excess water.

**Constriction** -----A control section, such as a bridge crossing, channel reach or dam, with limited flow capacity in which the discharge is related to the upstream water surface elevation; a constriction may be either natural or manmade.

**Construction Detail** -----A drawing of a BMP showing all critical dimensions and elevations.

**Construction Sequence (aka BMP sequence)** -----A step-by-step description of a proposed earthmoving activity relating the various stages of construction to the BMPs that are to be installed prior to each stage. It should also describe the conditions of stabilization that will exist prior to removal of temporary BMPs or their conversion to permanent stormwater management facilities as well as the process of converting those facilities.

**Continuity Equation** ----- $Q = VA$

Where: Q = Flow volume (cfs)  
V = Flow velocity (fps)  
A = Cross-sectional area of pipe or channel (sq. ft.)

**Contour** -----A line connecting points having the same elevation on a topographic map.

**Contour Cropping** -----Tillage and planting of a crop across, rather than up and down, a slope in order to reduce soil loss.

**Contour Strips** -----The practice of farming sloped land using alternating crops in such a way that plowing, preparing land, planting and cultivating are done on the contour as part of an agricultural operation. Contour strips without drainage are not regulated.

**Contour Interval** -----Difference in elevation between two adjacent contours.

**Contraction** -----A decrease in the width or depth of flow caused by the geometry of a weir, orifice, or obstruction.

**Contributing Drainage Area** ----- Total area upslope of a BMP that contributes runoff to that BMP

**Control Facility** -----A BMP designed to control/filter runoff.

**Control Guideline 1 (CG1)** -----A procedure recommended by the Department's Stormwater Best Management Practices (BMP) Manual for designing Post Construction Stormwater Management Plans.

**Control Measure** -----A Conservation Practice designed to minimize the potential for Accelerated Erosion.

**Controlled Growth** -----The imposition of restrictions on the amount or type of new development in an area.

**Conveyance** -----The process of water moving from one location to another; a measure of the ability of a stream, channel or conduit to convey water; a comparative measure of the water-carrying capacity of a channel

**Conveyance Channel** -----A channel constructed for the purpose of conveying clean water through or around a work area, such as outlet channels from sediment basins or traps, temporary stream relocations, etc.).

**Cool Season Grass** -----Species of grass whose primary growing seasons are in the spring and fall — they are largely dormant during the hottest part of the summer — including bluegrass, fescue, bentgrass, and ryegrass.

**Co-Permittee** -----A discharger of stormwater associated with construction activity that is jointly and individually responsible for compliance with all conditions of a permit and applicable laws with another entity for discharges to surface waters from the construction activity.

**Core** -----A zone of material of low permeability in a basin or pond embankment.

**Core Drilling** -----The process by which a cylindrical sample of rock and other strata is obtained through the use of a hollow drilling bit that cuts and retains a section of the rock or other strata penetrated.

**Core Trench** -----The trench in the foundation material under an earth embankment or dam in which special material is placed to reduce seepage. Also called key trench.

**Core Wall** -----A wall built of impervious material, usually of asphalt or concrete in the body of an embankment dam to prevent leakage.

**Coring** -----A method of drilling in which soil and rock samples are removed by means of hollow tines or spoons.

**Corrosive Soil** ----- Any soil with a high risk of corrosion to uncoated steel or deterioration of concrete. The risk of corrosion pertains to potential soil-induced electrochemical or chemical action that dissolves or weakens uncoated steel or concrete.

**Corrugated** -----Having parallel ridges and grooves.

**Corrugated Steel** -----Steel that is galvanized and corrugated.

**Cost Effective** -----Providing the optimum effect at the most reasonable cost.

**Cover Crop** -----Any vegetation producing a protecting mat on or just above the soil surface.

**Creep** -----Slow mass movement of rock or soil downslope.

**Creosote** -----Coal tar based chemical preservative used to treat wood to protect it from decay and deterioration.

**Crest** -----1. The top of a dam, dike, or spillway, which water must reach before passing over the structure.  
2. The highest elevation reached by flood waters at a specific location.

**Crib Structure** -----A hollow structure of interlocking perpendicular beams — filled with rock or earth — used for stabilizing stream banks.

**Critical Area** -----That part of a disturbed area which poses the greatest threat of sediment pollution to a receiving water

**Stream Channel:** Within the floodway

**Wetland:** Within 50 feet

**Steep Slopes:** Any slope 3H:1V or steeper directly above a surface water.

**Erodible Soils:** Any slope 3H:1V or steeper directly above a surface water.

**Critical Depth** -----The flow depth at which the specific energy for a given discharge rate is a minimum. Since water passes through this depth, it is hard to find in nature. Flow is critical when the Froude number is equal to one.

**Critical Flow** -----The flow conditions at which the discharge is a maximum for a given specific energy, or at which the specific energy is a minimum and the Froude number is equal to 1.0 for a given discharge.

**Critical Slope** -----The slope that will sustain a given discharge at uniform, Critical Depth in a given channel.

**Critical Velocity** -----The velocity that minimizes specific energy. A wave caused by a disturbance cannot move upstream in a channel where flow is at critical velocity.

**Cross Drain** -----A structure, usually a culvert pipe, used to convey runoff from a roadside ditch to a discharge point below the roadway.

**Cross Vanes** -----Rock structures that extend across a stream channel from bank to bank; they are keyed into the bankfull elevation in order to control the channel carving flow.

**Cross-section** -----A section formed by a plane cutting an area, usually at right angles to an axis.

**Cross-sectional Area** -----The surface area of a form or structure formed by a plane cutting it at right angles to an axis.

**Crown** -----The inside top elevation of a conduit.

**Crowned Roadway** -----A roadway graded so as to be higher in the center of the roadway than at either side. This is to promote drainage of runoff from the roadway into a roadside ditch or to an adjacent vegetated area.

**Crows Foot** -----Marked survey stake, which shows the cut/fill needed during grading operations.

**Crust** -----A dry surface layer on soils that is much more compact, hard, and brittle than the material immediately beneath it.

**CSL** -----Pennsylvania Clean Streams Law (35 P.S. §§ 691.1—691.1001).

**C-TRM** -----Composite turf reinforcement mat.

**Cubic Foot Per Second** -----A unit expressing rate of discharge, typically used in measuring pipe or channel flow. One cubic foot per second is equal to the discharge of a pipe or channel having a cross-section of 1 square foot and flowing at an average velocity of 1 foot per second. It is equivalent to 7.48 gallons per second, 448.83 gallons per minute, 1.9835 acre-feet per day, or 723.97 acre-feet per year.

**Cul-de-sac** -----Street that is closed at one end with a circular turnaround area and only one outlet.

**Cultural Resource Notice** -----A notice given by the project applicant to PHMC regarding the intended activity for which the applicant needs DEP's permit or plan approval.

**Culvert** -----A pipe or box used to convey runoff or stream flow under a roadway or embankment to a discharge point on the downslope side. (See Standard Construction Detail # 3-10, 3-13, and 3-14)

**Curb** -----Raised concrete border constructed along a street or sidewalk.

**Curb Inlet Sediment Barrier** -----A temporary barrier, such as concrete block and gravel, constructed around curb storm sewer inlets to reduce sediment discharge to the storm sewer. See Standard Construction Detail #s 4-15, 4-17, 4-19, and 4-22.

**Curb Stake** -----Survey stake used to locate the curb grade that is to be cut.

**Curled Wood Matting** -----A type of erosion control blanket used to minimize erosion on cut slopes or fill slopes or in constructed channels until a protective vegetative cover can be established.

**Curlex** -----A brand name often used to signify curled wood matting.

**Current Meter** -----A device that is lowered into a stream in order to record the rate at which the current is moving.

**Cut** -----1. An area from which earth material has been or will be removed by excavation. 2. The depth from original ground surface to the excavated surface.

**Cut and Cover** -----A method of trenching and laying pipe by using the soil from one section to cover the pipe in an adjoining section, thereby eliminating the need to remove a large amount of soil.

**Cut and Fill** -----The process of earthmoving by excavating from one area and constructing a nearby fill from the excavated material.

**Cut Bank** -----The outside bank of a stream channel at a sharp bend; often eroding and across from a point bar.

**Cut Stake** -----Survey stake indicating cut locations for earthmoving.

**Cutback Asphalt** -----Asphalt which has cutterstock petroleum distillates added to keep it liquid when temperatures are lower than optimum.

**Cutbanks Cave** -----In soils, the walls of excavations tend to cave in or slough.

**Cutting** -----A leaf, stem or branch cut from a plant to establish a new plant.

**Cutoff** -----1. A channel cut across the neck of a meander. 2. In dams, it is an impervious construction or material which reduces or prevents seepage from passing through the foundation material of the dam.

**Cutoff Trench** -----In dams, it is an excavation later to be filled with impervious material to form a cutoff.

**Cut Slope** -----The exposed slope resulting from removal of material from a hillside.

**CWA** -----Federal Water Pollution Control Act (33 U.S.C.A. §§1251—1376).

**CWF** -----Cold water fish stream classification.

## D

**D** -----The symbol for the total depth of a channel.

**d** -----The symbol for the anticipated flow depth of a channel.

**Dam** -----A barrier constructed for the purpose of impounding water.

**Dam Safety and Encroachments Act** -----PA law restricting the design of dams and structures and fills which could result in flood damage during or after storm events (32 P.,S. §§ 693.1—693.27).

**Dam Safety and Waterway Management Regulations** -----The Department's regulations developed in order to enforce the Dam Safety and Encroachment Act (25 Pa. Code §§ 105.1—105.452).

**Datum** -----Any numerical or geometric quantity or set of quantities that may serve as a reference or base for other, comparable quantities (e.g. Mean Sea Level).

**Daylight** -----In stream channel restoration, the excavation and restoration of a stream channel from an underground culvert, covering, or pipe.

**DCNR** -----Department of Conservation and Natural Resources.

**Deminimis** -----Too small or trifling to be covered by law (e.g. a deminimis wetland is  $\leq$  .05 acre).

**Dead Storage** -----In a sediment basin or trap, it is a portion of the storage area that is typically bypassed by water traveling through the impoundment from the point of entry to the principal spillway.

**Deadman** -----A log or block of concrete, or material buried in a stream bank for the purpose of tying in a revetment with cable, chain, or steel rods.

**Deflector** -----A structural barrier (groin, jetty, etc.) projecting into a stream channel to divert flow away from an eroding section of stream bank.

**Degradation** -----The lowering of a streambed by scour and erosion.

**Delineation** -----The process of deciding where something begins and ends (e.g. wetland boundaries).

**Density** -----The mass of a substance per unit volume.

**Deoxygenation** -----The process of removing dissolved oxygen from water.

**DEP** -----The Department of Environmental Protection.

**Department (The)** -----The Department of Environmental Protection.

**Depth-Area-Duration Analysis** -----A study made to determine the maximum amounts of rain within a given time period over a given area.

**Depression Storage** -----In TR-55, it is water contained in natural depressions in the land surface, such as puddles.

**Desiccation Cracks** -----Surface fractures resulting from the drying of soil or porous sedimentary rock.

**Design Capacity** -----The amount of water a structure is designed to hold or convey under certain restrictions.

**Design Criteria** -----Guidelines upon which planning and engineering decisions and judgments are based.

**Design Discharge** -----1. The anticipated rate or volume of flow as a result of a specified storm intensity, usually expressed in cubic feet per second (CFS). 2. The discharge produced by impounded water at a specified stage.

**Design Elevation** -----In dams, it is the height above a defined datum describing the required elevation of pool that will provide the required temporary storage.

**Design Flow (Q<sub>r</sub>)** -----The anticipated peak flow from a Design Storm that a BMP must be able to convey while providing sufficient freeboard.

**Design Frequency** -----The recurrence interval for hydrologic events used for design purposes (e.g. a design frequency of 10 years means a storm of such magnitude that it would occur an average of once every 10 years).

**Design High Water Elevation** -----1. The water surface elevation in a basin, pond, or dam at which the required discharge rate and/or storage capacity is provided. 2. The flow depth in a channel at which the required channel capacity is provided.

**Design Life** -----The period of time for which a BMP or other facility is expected to perform its intended function.

**Design Standards** -----Detailed engineering drawings and/or specifications promulgated by public or private organizations that leave little choice to design engineers and technicians.

**Design Storm** -----The rainfall duration and return frequency used to size a BMP (e.g. for E&S purposes, Temporary BMPs not located in Special Protection Watersheds are generally designed to have sufficient capacity for the anticipated runoff from a 1-hour storm that has a return frequency of once every 2 years, i.e. a storm of that intensity occurs on average once every 2 years). (See Chapter 5)

**Designated Uses** -----Uses of surface waters specified in 25 Pa. Code §§ 93.4(a) and 93.9a-93.9z for each water body or segment whether or not they are being attained.

**Detachment** -----The removal of transportable fragments of soil material from a soil mass by an eroding agent. Through detachment, soil particles or aggregates are made ready for transport (soil erosion).

**Detention** -----The process of temporarily collecting and holding back storm water for later release to receiving waters.

- **On-Site Detention** -----Temporary Storage of runoff on the same land development site where the runoff is generated.
- **On-Stream Detention** -----Temporary storage of runoff within a principal drainage system, receiving stream or conduit.
- **Off-Stream Detention** ----- Temporary storage accomplished off-line — not within a principal drainage system.

**Detention Facility** -----A storage pond or tank (above or below ground) that temporarily stores stormwater runoff and releases it at a slower rate than it was collected. Typically, there is little or no infiltration.

**Detention Pond** -----An impoundment used for stormwater management to delay the peak runoff from a site long enough to minimize the potential for downstream flooding.

**Detention Storage** -----Temporary storage of excess runoff in surface ponds, or underground tanks, for the purpose of attenuating the peak flow rate.

**Detention Time** -----The time required for a drop of water to pass through a detention facility when the facility is filled to design capacity.

**Determination Letter** -----A letter given by PHMC to a project applicant indicating PHMC's determination of the historical or archaeological significance of the site of the project applicant's intended activity.

**Detritus** -----Rock, gravel, sand, silt or other material carried by flowing water.

**Dewater** -----To remove water from all or part of a storage facility in a controlled fashion within a specified period of time.

**Dewatering Facility** -----A BMP used to dewater an impoundment. In erosion control, it usually refers to the facility used to dewater the sediment storage zone of a Sediment Basin or Trap.

**Dewatering Time** -----The time required to dewater a Sediment Basin or Trap from the top of the Dewatering Zone (Top of Riser) to the top of the Sediment Storage Zone (Lowest Row of Perforations). **Dewatering Zone** -----Formerly called the Settling Zone, the part of the storage capacity of a sediment basin or trap extending from the top of the sediment storage zone to the elevation at which the required storage capacity is provided.

**Diabase** -----A rock of basaltic composition resulting from an igneous intrusion.

**Diaphragm** -----A filter medium constructed around the outlet barrel of a basin to prevent piping. (See Figure 7.8)

**Dike** -----1. A low berm constructed for the purpose of directing runoff to a desired discharge point. 2. An embankment constructed along a stream channel to prevent overflow of lowlands, such as a levee). 3. A structure designed to either reduce water velocity as stream flow passes through the dike so that sediment deposition occurs on the upstream side (permeable dike), or to deflect erosive currents away from the stream bank (impermeable dike); also groin, palisade, spur, jetty, or deflector.

**Dilution Disposal** -----Relying on a large water volume, such as from a lake or stream, to dilute waste to an acceptable concentration — not typically an acceptable practice in Pennsylvania.

**Direct Precipitation** -----Water that falls directly into a lake or stream without passing through any land phase of the runoff cycle.

**Direct Runoff** -----The stream flow produced in response to a rainfall event; it is equal to total stream flow minus baseflow.

**Direct Seeding** -----A method of establishing a stand of vegetation by sowing seed directly on the ground surface.

**Director** -----The Director of the Bureau of Clean Water or any authorized employee thereof.

**Discharge** -----Volume of water exiting a pipe, channel, or impoundment (or passing a given point) during a given period of time — usually measured in cubic feet per second, CFS or gallons per minute, GPM.

**Discharge Coefficient** -----The ratio of the actual rate of flow to the theoretical rate of flow through orifices, weirs, or other structures.

**Discharge Point** -----A location at which effluent is discharged.

**Discharge Velocity** -----The velocity at which water being conveyed by a channel or pipe exits that structure.

**Dispersion, Soil** -----The breaking down of soil aggregates into individual particles, resulting in single grain structure. Ease of dispersion is a factor in the erodibility of a soil; the more easily dispersed a soil, the more erodible it is.

**Dissolved Solids** -----The weight of matter in true solution in a stated volume of water, including both inorganic and organic matter.

**Distressed Stream Bank** -----A bank experiencing erosion or failure.

**Disturbed Area** -----That part of an earthmoving project from which the vegetative cover has been removed to the extent that the potential for accelerated erosion exists.

**Ditch** -----An excavated water conveyance parallel to a roadway.

**Ditch Check** ----- Barrier place in a ditch to decrease the slope of the flowline and thereby decrease the velocity of the water. Note: This practice is not recommended by the Department.

**Diversion** -----A facility, including a channel or a conveyance constructed up-slope of the disturbed area to divert clean offsite runoff away from the earth disturbance activity.

**Diversion Channel** -----A channel constructed for the purpose of diverting upslope runoff around a work area.

**Diversion Dike** -----A barrier constructed to divert surface runoff.

**Diversion Terrace** -----A channel, dike, or terrace constructed for diverting upslope runoff around a work area.

**Divide** -----An imaginary line indicating the limits of a watershed or drainage area.

**Dormant Seeding** -----Application of cool season grass seed during late fall or early winter for germination the following spring.

**DOT** -----Generic term for a department of transportation (federal or state).

**Downdrift** -----The transportation of materials along a shoreline.

**Downstream block** -----An obstruction placed within a roadside ditch to direct flow into a cross drain culvert.

**Drag** ----- The retarding force acting on a body moving through a gas or liquid.

**Drain** -----In dams, it is an appurtenance installed in the dam and/or its foundation to safely collect and discharge seepage water.

**Drainage Area** -----The area above a BMP from which runoff would normally drain to that BMP.

**Drainage Basin** -----A geographic and hydrologic sub-unit of a watershed.

**Drainage Density** -----The total length of streams in a watershed divided by the drainage area.

**Drainage Divide** -----The boundary, along a topographic high, between one drainage basin and another.

**Drainage Easement** -----A legal encumbrance that is placed against a property's title to reserve specified privileges for the users and beneficiaries of the drainage facilities contained within the boundaries of the easement.

**Drainage Patterns** -----The drainage paths stormwater runoff usually or historically takes through a given area.

**Drainage, Soil** -----The frequency and duration of periods when the soil is free from saturation.

**Well-drained** -----Excess water drains away rapidly, and no mottling occurs within 36" of the surface.

**Moderately Well-drained** -----Water is removed from the soil somewhat slowly, resulting in small but significant periods of wetness. Mottling occurs within 18" to 36" of the surface.

**Somewhat Poorly-drained** -----Water is removed from the soil slowly enough to keep it wet for significant periods, but not all the time. Mottling occurs between 8" and 18" of the surface.

**Poorly Drained** -----Water is removed so slowly that the soil is wet for a large part of the time. Mottling occurs between 0 and 8" of the surface.

**Very Poorly Drained** -----Water is removed so slowly that the water table remains at or near the surface most of the time. There may also be periods of surface ponding. The soil has a black to gray surface layer with mottles up to the surface.

**Drainage Course** -----A natural or artificial depression that conveys surface runoff to a larger watercourse, lake, or bay.

**Drawdown** -----Lowering of the water surface in an open channel, impoundment, or groundwater aquifer.

**Dredge** -----To remove sand, gravel, mud, or other materials from the beds of regulated water of the Commonwealth.

**Dredge Material** -----Material that has been excavated or dredged from a stream channel, lake, or other body of surface water.

**Dredging** -----A method for deepening streams or other water bodies by scraping and removing solid materials from the bottom.

**Drill Seeding** -----Planting seed with a drill in relatively narrow rows (usually < 1 foot apart).

**Drop Inlet** -----In dams, it is a vertical entrance joined to a barrel section of a principal spillway system.

**Drop Spillway** -----An overall structure in which water drops over a vertical wall onto a protected apron at a lower elevation.

**Drop Structure** -----A structure designed to drop water vertically to a lower level, dissipating its surplus energy, without causing accelerated erosion. See Figure 9.11.

**Droughty** -----Exhibiting a poor moisture-holding capacity due to high permeability and low fines content.

**Drumlin** -----An elongated hill or ridge of glacial drift.

**Dry Basin** -----A basin that has an outlet structure designed so that essentially all stored water will be drained from the impoundment by gravity.

**Dry Weather Flow** -----See Base Flow

**Dry Well** -----1. A catch basin with open bottom and perforated walls used to store rooftop or surface runoff for infiltration into the ground. 2. A seepage pit.

**Dumped Rock Protection** -----Sound, durable stone or concrete rubble, insoluble in water and placed by dumping for the purpose of protecting against erosion, scour or sloughing of a bank.

**Dunes** -----Ridges or mounds of loose, wind-blown material, usually sand.

**Duration Curve** -----A graph showing the percentage of time a given flow of a stream will be equaled or exceeded based upon a statistical study of historic streamflow records.

# E

**E&S Permit** -----Erosion and Sediment Control Permit—A permit required for earth disturbance activities where the earth disturbance is associated with timber harvesting, road maintenance activities, or oil and gas activities.



**E&S Plan** -----Erosion and Sediment Control Plan. A site-specific plan consisting of both drawings and a narrative that identifies BMPs to minimize accelerated erosion and sedimentation before, during and after earth disturbance activities.

**EA** -----Environmental Assessment

**Earth Dam** -----A dam, the main section of which, is composed principally of earth, gravel, sand, silt, and clay. Also called an Earthfill Dam.

**Earth Disturbance Activity** -----A construction or other human activity which disturbs the surface of the land, including land clearing and grubbing, grading, excavations, embankments, land development, agricultural plowing or tilling, operation of animal heavy use areas, timber harvesting activities, road maintenance activities, oil and gas activities, well drilling, mineral extraction, and the moving, depositing, stockpiling, or storing of soil, rock or earth minerals.

**Earth Fill** -----Soil, sand, gravel, or rock construction materials used to build a structure or fill a void adjacent to it.

**Earthen Berm** -----A berm constructed from earthen materials as opposed to concrete, wood, or other building material.

**Earthmoving Activity** -----Any construction or other activity which disturbs the surface of the land, including, but not limited to, excavations, embankments, land development, subdivision development, mineral extraction and the moving, depositing or storing of soil, rock or earth. This includes any excavation or fill within a stream channel.

**Easement** -----A legal instrument enabling the giving, selling, or taking of certain land or water rights without transfer of title, such as for passage of utility lines. An affirmative easement gives the owner of the easement the right to use the land for a stated purpose. A negative easement is an agreement with a private property owner to limit the development of his land in specific ways.

**Easement, Express** ----A legal written document providing easement rights.

**Easily Erodible Soil** -----Any soil having a K-factor > 0.37

**Eddy Current** -----A water current running contrary to the main current. The eddy current may be set up between the main flow and the bank.

**Effective Calcium Carbonate (ECC)** -----A measure of the ability of a liming material to neutralize soil acidity, expressed as a percentage. For agricultural lime, it is about 50%.

**Effective Porosity** -----The usable pore spaces in a rock for the transmission of groundwater.

**Effective Precipitation** -----That portion of total precipitation that becomes available for plant growth. It does not include deep percolation below the root zone or surface runoff.

**Effluent** -----1. Something that flows out or forth, especially a stream flowing out of a body of water.  
2. Discharged wastewater such as the treated wastes from a municipal sewage plant, brine wastewater from oil or gas well drilling, or coolant waters from a nuclear power plant.

**Effluent Limitation** -----An amount or concentration of water pollutant that can be legally discharged into surface waters.

**Elevation** -----1. The vertical distance of a point from Mean Sea Level. 2. In retrofitting, the process of raising a house or other building so that it is above the height of a given flood.

**eMAP** -----A digitally-based series of maps available at [www.emappa.dep.state.pa.us](http://www.emappa.dep.state.pa.us).

**Embankment** -----1. A high berm constructed for the purpose of impounding water, such as in a Sediment Basin or Trap. 2. The part of the soil adjacent to a stream, lake, or body of water which is higher than the normal water level. 3. A raised structure used to carry a roadway.

**Embankment Sediment Trap** -----A sediment trap having a spillway constructed out of R-3 rock, filter stone, and filter cloth (see Standard Construction Detail #8-1).

**Embedment** -----The depth to which a support stake, such as for a silt fence or straw bale barrier, is driven into the ground.

**Emergence** -----The process of plant seedlings rising above the soil surface.

**Emergency Permit** -----Permits issued to alleviate imminent threat to life, property, or the environment.

**Emergency Spillway** -----The low point on the embankment of a Basin or Pond designed to provide a controlled discharge of the impoundment during very intense storm events. This is for safety purposes, to prevent failure of the impoundment due to overtopping of the embankment.

**Emergent Wetlands** -----Wetlands dominated by grasses and grass-like plants.

**Encroachment** -----A structure or activity which changes, expands, or diminishes the course, current, or cross section of a watercourse, floodway, or body of water.

**End Section** -----Flared attachment on an inlet or outlet of a culvert to prevent erosion of the overlying fill, improve hydraulic efficiency, and improve appearance.

**Endangered Species** -----Any plant or animal threatened with extinction by man-made or natural changes throughout all or a significant part of its range. Such species have been identified by the Secretary of the Interior as “endangered” in accordance with the 1973 Endangered Species Act.

**Endwall** -----A structure installed at the discharge end of a pipe.

**Energy Dissipater** -----Outlet Protection placed below the discharge end of a pipe or channel to reduce the scouring capacity of the discharge.

**Enforcement Action** -----A legal action taken by the Department to cause a violator to comply with environmental laws, rules, and regulations. It may be in the form of a Consent Order and Agreement (COA) or an Order and usually involves payment of penalties.

**Engineered Soil** -----A selected soil of known properties placed in a prescribed manner.

**Entrance Head** -----The hydraulic head required to cause flow into a conduit; it includes both entrance loss and velocity head.

**Entrance Loss** -----The head lost in eddies and friction at the inlet of a culvert.

**Entrenchment** -----The degree to which a channel is incised.

**Environmental Defense Fund (EDF)** -----A national, non-profit environmental and conservation organization active in legal, economic, and scientific aspects of environmental issues.

**Environmental Due Diligence** -----Regarding clean fill, Investigative techniques, including but not limited to, visual property inspections, electronic data base searches, review of property ownership, review of property use history, Sanborn maps, environmental questionnaires, transaction screens, analytical testing, environmental assessments or audits.

**Environmental Review Committee** -----An inter-agency group comprised of state and federal resources agencies. Standing members include PADEP, PGC, PFBC, USFWS, EPA, and ACOE.

**Eolian Deposit (aka Aeolian)** -----Wind deposit; typically in the form of silt (loess) or sand dunes.

**EPA** -----The Environmental Protection Agency, a federal agency responsible for implementing the federal laws designed to protect the environment.

**Ephemeral Stream** -----A stream that flows only in direct response to precipitation.

**Equivalent Opening Size (EOS)** -----Number of the U.S. Bureau of Standards sieve (in mm or inches) having openings closest in size to the diameter of uniform particles that will allow 5% by weight to pass through, typically used to select filter fabric for use in filtration and separation.

**ERC** -----The Environmental Review Committee.

**Erodibility** -----Susceptibility to erosion.

**Erodibility K Factor** -----A measure of the susceptibility of soil particles to detachment and transport by rainfall and runoff.

**Erodible Soil (Easily)** -----A soil having an Erodibility Factor (K) > 0.37.

**Erosion** -----The loosening and removal by wind and/or water of soil and/or rock from its location and moving it to a place of deposition.

- **Accelerated Erosion** -----Erosion much more rapid than normal, primarily due to human activity
- **Geologic Erosion** -----The normal or natural erosion caused by geological processes acting over long periods of time, resulting in wearing away of mountains and building up of floodplains.
- **Gully Erosion** -----The erosion process whereby water accumulates in narrow channels over short periods, and removes the soil from this narrow area to considerable depths.
- **Natural Erosion** -----Wearing away of the earth’s surface by water, ice, or other natural agents under natural environmental conditions of climate, vegetation, etc.
- **Normal Erosion** -----The gradual erosion of land use by man that does not greatly exceed natural erosion.
- **Rill Erosion** -----An erosion process in which numerous small channels only several inches deep are formed.
- **Sheet Erosion** -----The removal of a fairly uniform layer of soil from the land surface by stormwater runoff.
- **Splash Erosion** -----The spattering of small soil particles caused by the impact of raindrops on unprotected soil. The loosened particles are often removed by subsequent surface runoff.

**Erosion and Sediment Control Permit** -----A permit required by 25 Pa. Code Chapter 102 for Timber Harvesting Activity or Roadway Maintenance Activity which disturbs 25 acres or more.

**E&S Plan** -----A site-specific plan identifying BMPs to minimize accelerated erosion and sedimentation and which meets the requirements of 25 Pa. Code Chapter 102 regulations. For agricultural plowing or tilling activities, the E&S Plan is that portion of a conservation plan identifying BMPs to minimize accelerated erosion and sedimentation.

**Erosion Control Blanket** -----A soil covering made from straw, coir, excelsior, or synthetic material — either rolled on or sprayed on — used to minimize the potential for erosion of an exposed soil until a suitable vegetative cover can be established. Temporary blankets made from biodegradable or photodegradable materials last several months to a year, while permanent blankets or turf reinforcement mats can last for several years.

**Erosion Resistant Soil** -----A soil having an Erodibility Factor (K)  $\leq$  0.37.

**ESA** -----The federal Endangered Species Act.

**Escarpment** -----A steep place or a ridge of high land.

**Esker** -----A narrow, winding ridge of stratified gravelly and sandy drift deposited by a stream flowing in a tunnel beneath a glacier.

**Estuary** -----An area where fresh water meets salt water.

**Eutrophic** -----Nutrient-rich. A eutrophic lake typically has a high surface area-to-volume ratio.

**Eutrophication** -----The enrichment of water with nutrients, usually phosphorous and nitrogen, which stimulates the growth of algal blooms and rooted aquatic vegetation and accelerates the aging of that water body.

**EV Watershed** -----Exceptional value watershed.

**Evapotranspiration** -----The combined loss of water from an area by evaporation and by transpiration of plants.

**Excavated Basin or Trap** -----A basin or trap constructed mainly by excavation in flat terrain. A relatively short embankment section on the downstream side may be necessary to provide the necessary storage or discharge capacity.

**Exceptional Value Waters** -----Surface waters of high quality which satisfy 25 Pa. Code §93.4b(b) (relating to antidegradation).

**Exceptional Value Wetlands** -----Wetlands as defined at 25 Pa. Code § 105.17(1).

**Excess Fines** -----Excess silt and clay in the soil. The soil does not provide a source of gravel or sand for construction purposes.

**Excess Rainfall** -----The amount of rainfall that runs directly off an area.

**Excess Runoff** -----Direct surface runoff that cannot be accommodated satisfactorily by the existing or planned drainage system.

**Existing Land Uses** -----The dominant land uses of a specific area for the five (5) years preceding a planned project. Note: This is not just the zoning of the land.

**Existing Uses** -----Uses of surface waters that are actually attained in the water body on or after November 28, 1975, whether or not they are included in the water quality standards.

**Exit Channel** -----The portion of an emergency spillway downstream from the control section (weir) that conducts flow to the point where it may be released without jeopardizing the embankment.

**Expired NPDES permit** -----A permit which was not renewed within 5 years of the date of issuance.

**Extended Detention Dry Ponds** -----Depressed basins that temporarily store a portion of the stormwater runoff following a storm event. The extended detention time of the stormwater provides an opportunity for urban pollutants carried by the flow to settle out.

**Extirpated Species** -----A species rendered extinct in a given area.

## F

**Fabric Formed Concrete Systems** -----Geotextile tubes and mattresses that are filled with concrete to provide a hard armor protection system to areas otherwise subject to scour.

**Fabridam** -----A dam formed of fabric and rubber that can be inflated with air or water.

**Face** -----In dams, it is the external surface of a structure, such as the surface of an appurtenance or dam.

**Face Planting** -----Planting vegetation in the frontal openings of retaining structures.

**Facultative** -----Able to live under different or changing conditions (e.g. plants able to grow in both wetland and upland conditions).

**Failure** -----The collapse or slippage of a large mass of bank material into a stream.

**Fallow** -----Cropland, either tilled or untilled, that has been allowed to lie idle during the whole or greater portion of the growing season.

**Fascine** -----Bundled willow, or other suitable species, cuttings used to stabilize a stream bank. Bundling allows otherwise weak green twigs to reinforce each other and resist the forces of stream currents. See Figure 15.7.

**Fault** -----A fracture plane in bedrock along which some movement has taken place.

**Fecal Coliform** -----Coliform bacteria present in the intestinal tracts and feces of worm-blooded animals.

**Federal Water Pollution Control Act** -----The Clean Water Act (33 U.S.C.A. §§ 1251—1376).

**FEMA** -----Federal Emergency Management Agency. An independent agency of the federal government founded in 1979 for the purpose of reducing loss of life and property while protecting the nation's infrastructure from all types of hazards, including flooding.

**Fens** -----Open, freshwater, peat-forming wetlands that are at least partially supplied by groundwater. Fens are not acidic, have higher nutrient levels than bogs, and support a more diverse plant and animal community.

**FERC** -----Federal Energy Regulatory Commission.

**Fertility** -----The ability of a soil to provide sufficient nutrients in the proper balance to promote the growth of specified plants when other growing conditions are favorable.

**Fertilizer** -----Any natural or manufactured material added to the soil to supply one or more required plant nutrients.

**Fertilizer Analysis** ----- The percentage composition of fertilizer expressed in terms of nitrogen, phosphoric acid, and potash. For example, a fertilizer with a 10-20-20 analysis contains 10 percent nitrogen (N), 20 percent available phosphoric acid (P<sub>2</sub>O<sub>5</sub>), and 20 percent water-soluble potash (K<sub>2</sub>O).

**Fertilizer Requirement** -----The quantity of certain plant nutrients that must be added to a soil to optimize growth of a desired plant or plants.

**FGM** -----1. Fluvial Geomorphology, 2. Flexible Growth Medium

**Fiber Roll**-----A sediment filter log. (See Standard Construction Detail # 4-11)

**Fibrous Root System** -----A plant root system having a large number of small, finely divided, widely spreading roots, but no large individual roots, such as grasses.

**Field Capacity** -----The amount of water a soil can hold.

**Filing Fee** -----The required payment — \$500 for a general permit and \$1500 for an individual permit, made payable to the appropriate county conservation district "Clean Water Fund" — due at the time an application for coverage under an NPDES permit is made.

**Fill** -----Soil, rock, gravel or other material that is placed at a specified location to bring the ground surface up to a desired elevation.

**Fill Height** -----The difference in elevation between the existing ground line and the proposed top of an earthen fill or embankment, including allowance for settlement.

**Fill Material** -----Soil that is placed at a specified location to bring the ground surface up to a desired elevation or angle of slope.

**Fill Slope** -----The outer slope of a fill.

**Filter** -----A layer of fabric, sand, gravel, or graded rock placed between a bank revetment or channel lining and the natural soil for one or more of the following purposes: a. to prevent soil from moving through the revetment, b. to prevent the revetment from sinking into the soil, c. to permit natural seepage from the stream bank, thus preventing buildup of excessive groundwater pressure.

**Filter and Drainage Diaphragm** -----Sand pack for preventing piping along a basin or pond outlet barrel. Note gravel wrapped in filter fabric is no longer recommended. (See Figure 7.8)

**Filter Fabric** -----A manufactured water-permeable geotextile material — woven or non-woven — used to filter sediment from runoff coming from a disturbed area. It is typically made from synthetic products such as polypropylene.

**Filter Fabric Fence** -----A sediment barrier constructed from filter fabric attached to support stakes. See Standard Construction Detail #s 4-7, through 4-10.

**Filter Layer** -----Well-graded, hard, durable, non-soluble particles — free from muck, topsoil, organic matter or rubbish — or geotextile fabric, placed under slope protection to prevent the natural soil of the bank from being washed away through the slope protection layer.

**Filter Strip** -----A strip or area of vegetation used for removing sediment, organic matter, and other pollutants from runoff and wastewater.

**Filtration** -----The process of retaining soils and other materials while allowing the passage of water or fluids.

**Fine Particles** -----Silt and clay particles, also called fines.

**Fine Textured Soil** -----Sandy clay, silty clay, and clay.

**Finished Grade** -----The final elevation of the ground surface conforming to the approved plan.

**First Flush** -----The first portion of runoff generated by a storm event containing the main portion of the pollutant load resulting from the storm.

**Fish and Boat Commission** -----See PA Fish and Boat Commission.

**Fish Habitat Enhancement Structure** -----Structures such as deflectors, low flow channels, channel blocks, muddills, boulders, felled shoreline trees, special tire structures, brush structures, rubble reefs, half-log structures, elevated boulder structures, and spawning/nursery structures that are placed in streams, lakes, ponds, or reservoirs as developed and approved by the PFBC. Such activity requires a GP-1.

**Fish Ladder** -----Artificial, stepped pools to enable fish traveling upstream to span a relatively large vertical distance in a series of gradual steps, typically used at dams or other stream barriers.

**Flanking** -----Stream flow between a structure and the bank, possibly occurring because the structure was not properly tied into the bank.

**Flexible Growth Medium (FGM)** -----An hydraulically-applied mulch containing heat-treated wood fibers, cross-linking tackifiers, and man-made fibers, which allows them to bond mechanically with the soil surface.

**Floc** -----Agglomerated colloidal particles.

**Flocculant** -----A chemical added to turbid water to accelerate the formation of clumps from fine-grained particles suspended in the water for the purpose of settling-out those particles prior to discharging into surface waters.

**Flocculation** -----The agglomeration of finely divided suspended solids into larger, usually gelatinous, particles.

**Flood** -----A general but temporary condition of partial or complete inundation of normally dry land areas from the overflow of streams, rivers, or other surface waters.

**Flood Control** -----Preventing the entry of stormwater into an area from another area, or from a stream or other water body.

**Flood Peak** -----The highest stage — greatest discharge rate — attained by a flood event.

**Flood Prone Soil** -----Soil susceptible to flooding during a 2-year frequency storm event.

**Flood Routing** -----An analytical technique used to compute the effects of system storage and system dynamics on the shape and movement of a flood wave.

**Flood Stage** -----The stage at which overflow of the natural banks of a stream begins.

**Floodgate** -----A gate placed in a channel or closed conduit to keep out floodwater or tidal backwater.

**Flooding (Soil)** -----Any soil subject to inundation during a 2-year/24 hour storm event.

**Floodplain** -----The land adjacent to a river or stream that has been, or could be, expected to be inundated by a flood resulting from a 100-year storm event.

**Floodwall** -----A flood barrier constructed of manmade materials, such as concrete or masonry.

**Floodway** -----The area of the floodplain required to carry the discharge from a 100-year storm event. Where no FEMA mapping has been completed, it is assumed to be 50' back from top of bank.

**Flow Length** -----The distance that runoff travels to or through a BMP.

**Flow Line** -----The bottom elevation of an open or closed conduit.

**Flow Path** -----The anticipated course that runoff will follow during a storm event.

**Flow Regime** -----1. In runoff calculations: overland, shallow concentrated, or channel flow. 2. In channel stability calculations: subcritical, critical, or supercritical flow. 3. In culvert capacity calculations: entrance control or exit control.

**Flow Time** -----The estimated time required for runoff to travel a specified distance in an anticipated flow regime, such as overland flow, shallow concentrated, or channel flow).

**Flowing Well** -----A well that flows under hydrostatic pressure to the surface.

**Flume** -----1. A pipe or section of pipe used to convey flow across trench or disturbed area. 2. A constructed channel lined with erosion-resistant materials used to convey water on steep grades without erosion.

**Fluvial Geomorphology (FGM)** ----- The study of a stream's interactions with the local climate, geology, topography, vegetation, and land use; the study of how a river carves its channel within its landscape.

**Fly Ash** -----The solids, ash, cinders, dust, soot, or other partially incinerated material removed from a gas stream, typically associated with coal-fired electric generating plants.

**Footing (Footer)** -----The supporting base or ground work of a structure.

**Forage** -----Unharvested plant material that can be used as feed by domestic animals. It may be grazed or cut for hay.

**Forb** -----Any herbaceous flowering plant other than grass or sedge.

**Force Main** -----A sewer line that is pressurized.

**Ford** -----A submerged stream crossing where vehicles travel at or near the stream bed.

**Forebay** -----1. The water behind a dam. 2. A reservoir or pond situated at the point where a channel or pipe discharges into a sediment basin or detention pond for the purpose of catching sediment and facilitating maintenance.

**Foreshore** -----The part of a shore lying between the crest of the berm, or upper limit of wave wash at high tide, and the ordinary low-water mark, typically traversed by the uprush and backrush of the waves as the tides rise and fall.

**Forest Stewardship Plan** -----A written plan that provides an overview of a woodland property in the context of a landowner's needs and objectives and serves as a means of communicating technical information in a concise form that is useful to the landowner.

**Forest/Woodland Land Use** -----Deciduous, evergreen or mixed forestland; woodlots in suburban or urban areas.

**Forested Wetland** -----Wetlands dominated by mature trees.

**Foundation Drain** -----A pipe or series of pipes designed to collect groundwater from the foundation or footing of a structure and convey it to a chosen discharge point.

**FPS, or fps** -----Feet per Second. (Velocity).

**Fracture** -----A break in rock caused by stresses, or release from stresses.

**Fragipan** -----A natural subsurface soil horizon with high bulk density compared to the soil column above it, seemingly cemented when dry but moderately to weakly brittle when moist.

**Free Flow** -----Flow through or over a structure not affected by submergence or backwater.

**Free Water** -----Water in soil that is free to move by gravity — in contrast to capillary or hygroscopic moisture.

**Freeboard** -----1. The vertical distance between the design maximum water elevation in a BMP and the top of the berm or embankment. 2. In dams, it is the distance between normal pool elevation and the top of the dam.

**Freeze-Thaw Resistance** -----Ability to resist movement and/or degradation caused by cycles of extreme temperature fluctuations above and below the freezing point.

**French Drain** -----A drainage device in which a hole or trench is backfilled with sand or gravel — sometimes with a perforated pipe.

**Frequency Curve** -----A graphical representation of the frequency of occurrence of specific events, such as storm events.

**Frequency of Storm** -----The average period of years that will elapse before another storm of equal intensity will recur. For example a 10-year storm can be expected to occur once during a 10-year period. Note: This is based on probabilities. Storms with large return periods, such as 100 years, have been known to follow closely after one another.

**Friable** -----1. Of rock, the characteristic of crumbling naturally or being easily broken, pulverized, or reduced to powder such as a poorly cemented sandstone. 2. Of soil, the consistency in which moist soil material crushes easily under gentle to moderate pressure — between thumb and forefinger — and coheres when pressed together.

**Frost Action (Soils)** -----The likelihood of upward or lateral expansion of the soil caused by the formation of segregated ice lenses, or frost heave, and the subsequent collapse of the soil and loss of strength on thawing, which can damage roads, buildings, and other structures as well as plant roots.

**Frost Heave** -----The raising of a surface or object due to the accumulation of ice in the underlying soil.

**Frost Line** -----The depth to which frost penetrates the soil.

**Froude Number** -----An expression used to classify channel flow into subcritical, critical, and supercritical flow. Flow is at critical depth when the Froude number is 1.

$$F = \frac{V}{(g D)^{0.5}}$$

Where: **V = Velocity (fps)**

**g = gravitational constant**

**D = hydraulic depth of flow (ft)**

A high Froude number (>1) indicates rapid (supercritical) flow, while a low Froude number (<1) indicates tranquil (subcritical) flow.

**Fugitive Dust** -----Particulate air-borne pollution from construction sites, unpaved roads, or other disturbed areas.

## G

**Gabion** -----A wire basket, usually rectangular, ( $\geq 12$ " high) filled with riprap used to stabilize stream banks, hillsides, and other areas subject to flowing water with high velocities.

**Gabion Mattress** -----A series of gabion baskets tied together by the manufacturer.

**Gaging Station** -----A selected section of stream channel equipped with a gage, recorder or other facilities for measuring streamflow.

**Gap-graded** -----A soil with a discontinuous range of soil particle sizes. For example, having large-sized particles and small-sized particles, but not medium-sized particles.

**Gage (Gauge)**-----1. A device for measuring precipitation, water level, discharge rate or volume, pressure, temperature, etc. 2. A measure of the thickness of metal, such as the diameter of wire.

**Gallons per Minute (GPM)** -----A measure of the rate of discharge typically used for well capacity or for flow rates less than 1 cfs. 1 cfs = 448.83 gpm.

**General Information Form (GIF)** -----An additional form (Document No. 8000-PM-IT001) required for Individual NPDES Permit Applications

### General 105 Permit (GP)

**GP-1** -----GP for Fish Habitat Enhancement Structures.

**GP-2** -----GP for Small Docks and Boat Launching Ramps.

**GP-3** -----GP for Bank Rehabilitation, Bank Protection and Gravel Bar Removal.

**GP-4** -----GP for Intake and Outfall Structures.

**GP-5** -----GP for Utility Line Stream Crossings.

**GP-6** -----GP for Agricultural Crossings and Ramps.

**GP-7** -----GP for Minor Road Crossings.

**GP-8** -----GP for Temporary Road Crossings.

**GP-9** -----GP for Agricultural Activities.

**GP-10** -----GP for Abandoned Mine Reclamation.

**GP-11** -----GP for Maintenance, Testing, Repair, Rehabilitation, or Replacement of Water Obstructions and Encroachments

**GP-15** -----GP for Private Residential Construction in Wetlands.

**General NPDES Permit** -----The category into which most construction permits fall. It is required for all earth disturbances greater than or equal to 1 acre in a non-special protection watershed. Earth disturbances associated with agricultural plowing and tilling and animal heavy use areas, timber harvesting, and roadway maintenance are exempt.

**Generic Permits** -----Chapter 105 permits issued to certain Commonwealth agencies, such as PennDOT, DCNR, the Game Commission, and the Turnpike Commission, for maintenance activities located in or along various streams.

**Geocell** -----A three-dimensional, permeable, polymeric — synthetic or natural — honeycomb or web structure, made of alternating strips of geotextiles, geogrids, or geomembranes. They are typically used for stabilizing steep slopes, high-velocity channels, or for constructing permeable parking areas.

**Geocomposite** -----A manufactured or assembled material having at least one geosynthetic product among the components.

**Geofoam** -----A polymeric material formed by the application of a polymer in semiliquid form through the use of a foaming agent. The result is a lightweight material with a high void content.

**Geographic Information System (GIS)** -----A system that links spatial information such as satellite images and maps with alphanumeric information to produce a geographically referenced database.

**Geogrid** -----A stiff, net-like polymeric material used to reinforce, stabilize, and/or contain soil, rock, earth or other material in a wide variety of applications including internally reinforced walls, segmented retaining walls, steep slopes, etc.

**Geologic Erosion** ----- The normal erosion that occurs due to natural processes acting over long periods of time without the influence of human activity.

**Geologic Map** -----A map showing one or more of the following: geologic formations outcropping at the surface, lithology, structure of bedrock, other geologic features such as faults, fracture traces, and slope movements.

**Geomat** -----A three-dimensional, permeable, polymeric — synthetic or natural — structure made of bonded filaments, used for soil protection and to bind roots and small plants in erosion control BMPs. A TRM.

**Geomembrane** -----An impervious thin sheet of rubber or plastic material that functions as a barrier to liquid or vapor.

**Geonet** -----1. A planar, polymeric structure consisting of a regular dense network whose constituent elements are linked by knots or extrusions and whose openings are much larger than the constituents, such as jute netting. 2. A stiff, polymeric net-like sheet with in-plane openings used primarily as a drainage material within landfills or in soil and rock masses.

**Geosynthetic** -----A planar, polymeric (synthetic or natural) material.

**Geotextile** -----A fabric manufactured from synthetic fiber (usually non-biodegradable, either woven or non-woven) that is designed to achieve specific engineering objectives, including seepage control, separation of materials, filtration, or protection of other construction materials.

**Geotextile Tube** -----A long, capsular structure filled with sand, often used to retard shoreline erosion.

**Geothermal** -----Terrestrial heat, usually associated with deep-seated groundwater. The normal thermal gradient of the earth's crust is such that the temperature in a deep well or mine typically increases by about 1°F for each 100 feet of depth.

**Germination** -----The beginning of plant growth. The sprouting of roots, stems, and leaves from seed.

**GIS** -----See Geographic Information System.

**GISDRG** -----GIS Digital Raster Graphics

**Glacial Drift** -----Earth material transported and deposited by the ice and/or water flowing from a glacier.

**Glacial Till** -----Soil deposited by a receding glacier, composed of mixed clay, sand, gravel, and boulders.

**Gleyed Soil** -----Soil that formed under poor drainage, resulting in the reduction of iron and other elements in the profile and in gray colors and mottles.

**Global Positioning System (GPS)** -----A network of satellites that emit continuous location-finding radio signals; GPS receivers use the signals from multiple satellites to determine their exact three-dimensional location including latitude, longitude, and altitude.

**GPM** -----See Gallons Per Minute.

**GPS** -----See Global Positioning System.

**Gradation** -----The distribution of particle sizes in a material.



**Grade** -----1. The slope of a road or trail expressed as a percent change in elevation per unit of distance traveled. 2. The finished surface of a roadbed, utility trench, fill, or excavation.

**Grade Stabilization Structure** -----See Drop Structure.

**Graded Stream** -----A natural channel that has achieved the necessary flow characteristics for transporting the amount of sediment supplied by its drainage basin.

**Grading** -----Changing the shape of the land's surface to facilitate building, transportation, or other human activity.

**Gradient** -----Change in elevation, velocity, pressure, or other measurable characteristic per unit length, slope.

**Grain** -----A unit of weight equal to 1/7,000 pound or 0.0648 gram.

**Grassed Waterway** -----A natural or constructed waterway, typically broad and shallow, covered with an erosion-resistant grass.

**Grate** -----A metal frame of parallel bars placed in the entrance to a storm sewer inlet to prevent debris, animals, etc. from entering the sewer line.

**Gravel** -----1. Soil particles ranging from 1/5" (2 mm) to 3" (7.6 cm) in diameter. 2. The material retained on a No. 4 sieve.

**Gravel Bars** -----Alluvial deposits in stream channels, including accumulations of gravel, glacial till, sediment, silt and flood debris, that obstruct and redirect flow, and are thereby associated with stream bank erosion.

**Gravitational Water** -----Free water in transit downward through the vadose, or unsaturated, zone.

**Greenbelt** -----A strip of trees and/or shrubs growing parallel to a stream preventing overuse of the top bank area by people, animals, and machinery. It retards rainfall runoff down the bank slope and provides a root system that helps to bind soil particles together. Also called a greenway.

**Groin** -----1. The intersection between a fill and natural ground. 2. A shore protection structure, usually perpendicular to the shoreline, built to trap shoreline drift material or to retard erosion of the shore.

**Groin Ditch** -----A stabilized channel running down-slope parallel to a right-of-way or to the edge of a fill to safely convey runoff to a desired point of discharge.

**Grooving** -----A method of roughening a cut or fill slope in order to reduce the potential for gully formation on the slope until a suitable vegetative cover can be established.

**Groundcover** -----Low-growing, herbaceous or woody plants that spread vegetatively to produce a dense, continuous cover.

**Groundwater** -----Water found below the surface of the land, usually in permeable rock formations. It is the source of water for wells and springs.

**Groundwater Flow** -----Water moving through the subsurface soil and rock.

**Groundwater Infiltration** -----The seepage of groundwater into a sewer line.

**Groundwater Runoff** -----The seepage of groundwater into a stream channel.

**Groundwater Table** -----The depth below the surface where the soil or rock is saturated, such as open spaces between individual particles filled with water.

**Grout** -----A fluid mixture of cement, water and sand or other fillers that can be poured or pumped easily. Used to fill voids in riprap, culverts, or other structures in channels or slopes, intended to prevent or reduce erosion or inadvertent water flow.

**Grout Curtain (Grout Cutoff)** -----A barrier produced by injecting grout into a vertical zone, usually narrow horizontally, in the foundation of a dam to reduce seepage under the dam.

**Grouted Riprap** -----Riprap that has been coated with a specialized type of concrete that is designed to fill voids and reduce the potential for movement of the stone during high flow/high velocity conditions. This is generally accomplished by placing the riprap on a layer of grout, then covering with another layer of grout.

**Growing Season** -----The season that, in general, is warm enough for the growth of plants 1. Time from the last killing frost of spring to the first killing frost in autumn. 2 That period of the year when the daily mean temperatures are above 42° F.

**Grubbing** -----The operation of removing stumps and roots.

**Gully** -----An erosion channel too large to cross with a wheeled vehicle.

**Gully Erosion** -----An advanced form of rill erosion, in which large channels are incised into the soil by water runoff.

**Gumbo** -----Silty soil that becomes, soapy, sticky, or waxy when wet.

**Guy Wire** -----A support wire used to keep the stakes of Reinforced Silt fence erect (see Standard Construction Detail #4-8).

# H

**Hard Armor** -----Non-living erosion protection, such as riprap, concrete, gabions, etc.

**Hardness** -----A measure of soap-neutralizing ions present in water; predominantly magnesium and calcium, but other alkali metal ions contribute to the effect.

**Hardpan** -----Layer of extremely dense, nearly impermeable soil — chiefly clay or organic materials — beneath a more permeable soil, formed by natural chemical cementation of the soil particles.

**Haul Road** -----A temporary dirt, gravel, or stoned roadway used during earth disturbance activities to access a work area.

**Hazardous Material** -----Any substance, pollutant or contaminant listed as hazardous under the Comprehensive Environmental Response, Compensation, and Liability Act (CERCLA) of 1980.

**Head** -----1. The difference in elevation between a water elevation and a point in question (e.g. crest of a riser, outlet barrel elevation, etc.). 2. In culvert pipe calculations:

A) For inlet control, it is the difference in elevation between the highest attainable water level and the pipe invert.

B) For outlet control, it is the difference in elevation between the highest attainable water level above the culvert and the level of the water below the culvert.

**Head Cut** ----- The point at the upstream end of a channel where it grows and lengthens, also called a “nick point”.

**Head Cut Control Structures** -----BMPs designed to break up erosive energy at a head cut, often in the form of stair steps constructed out of logs or rocks in conjunction with erosion control blanketing.

**Head Cutting** -----1. Headward erosion of a locally steep channel or gully. 2. The action of an upstream moving waterfall or locally steep channel bottom with rapidly flowing water through an otherwise placid stream. These conditions often indicate that a readjustment of a stream’s discharge and sediment load characteristics is taking place.

**Head Gate** -----A water control structure. A gate at the entrance to a conduit.

**Head Loss** -----1. The decrease in total head caused by friction. 2. The effect of obstructions, such as narrow bridge openings or buildings that limit the area through which water can flow, raising the surface of the water upstream from the obstruction.

**Headwall** -----The wall placed around the opening of a culvert, storm sewer, etc.

**Headwater** -----1. The source and upper reaches of a stream or reservoir. 2. In culverts, it is the depth of the upstream water surface measured from the invert of the culvert entrance.

**Heaving** -----The partial lifting of plants out of the ground, frequently breaking their roots, during the freeze-thaw cycles of winter.

**Hectare** -----A metric unit of area equal to 10,000 square meters (107,639 square feet).

**Herbaceous Plant**-----A plant with no persistent woody stem above ground.

**HGIS** -----the Pennsylvania Natural Heritage Program database, formerly PNDI, available at [www.naturalheritage.state.pa.us](http://www.naturalheritage.state.pa.us).

**High-Density Polyethylene (HDPE)** -----A synthetic polymer used for geomembranes and pond liners.

**High Quality Waters** -----Surface waters having quality which exceeds levels necessary to support propagation of fish, shellfish, and wildlife and recreation in and on the water by satisfying 25 Pa. Code § 93.4b(a).

**Highwall** -----The unexcavated face of exposed overburden and coal, or other mineral being extracted, in a surface mine or quarry.

**Historic Resource** -----A building, structure, object, district, place, site, or area significant in the history, architecture, maritime heritage, archaeology, or culture of this Commonwealth, its communities or the nation.

**Histosols** -----Organic soils.

**Holding Structure** -----Any excavation, pond, or closed embankment used to contain water or another solution until needed.

**Horizon** -----A layer of soil with different color or composition than the layers above and below it.

**HQ Watershed** -----High quality watershed.

**Humic Acid** -----The alkaline-soluble portion of organic material — humus — that precipitates from solution at low pH and is of high molecular weight. A breakdown product of cellulose from vascular plants.

**Humus** -----Organic materials resulting from decay of plant or animal matter.

**100-Year Flood** -----A flood level with a 1 percent or greater chance of being equaled or exceeded in any given year.

**HWM** -----High water mark, a mark indicating the highest level reached by a body of water.

**Hybrid Terrace** -----A method of planting on slopes to prevent soil loss and landslides; mulches, trees, vetiver grass, and rock walls are combined on the terraces to tie soils on the hillsides and provide gradient breaks where sediments can be deposited and nutrients retained.

**Hydration** -----The chemical reaction between water and cement.

**Hydraulic Gradient** -----A line which represents the relative force available due to the potential energy available. This is a combination of energy due to the height of the water and internal pressure. In an open channel, the line corresponds to the water surface.

**Hydraulic Head** -----1. The height of the free surface of a body of water above a given point beneath the surface. 2. The height of the water level at an upstream point of a waterway above the water surface at a given point downstream.

**Hydraulic Jump** -----An abrupt rise in water surface that occurs in open channel flow when water flowing at a high velocity is retarded. This occurs as the flow changes from supercritical flow to sub critical flow.

**Hydraulic Mulching** -----Applying wood fiber mulch and often a mixture of seed, water, and fertilizer in one application to help retain soil and moisture. Also called “hydromulching.”

**Hydraulic Radius** -----The cross-sectional area of a channel divided by its wetted perimeter (A/P). For a circular pipe flowing full, it is  $\frac{1}{4}$  the pipe diameter.

**Hydraulics** -----The study of water in motion.

**Hydric Inclusions** -----Relatively small (unmapped) areas of hydric soil located within larger areas (mapped) of otherwise non-hydric soil.

**Hydric Soil** -----A soil that is saturated, flooded, or ponded long enough during the growing season to develop anaerobic-conditions. When such a soil is located in an area that has hydrophytic vegetation and wetland hydrology, a wetland is present.

**Hydrograph** -----A graphical representation of the rate of flow, stage, velocity or other property of water at a specific point over a period of time (usually during a storm or flood event).

**Hydrologic Balance** -----An accounting of all water inflows to, water outflows from, and changes in water storage within a hydrologic unit over a specified period of time. Inflow = outflow + changes in storage.

**Hydrologic Cycle** -----The circuit of water movement from the atmosphere to the earth and back to the atmosphere by various processes such as precipitation, runoff, infiltration, evaporation, and transpiration.

**Hydrologic Soil Group** ---A classification of soils according to infiltration rates. Group A soils have the highest infiltration rates, and therefore, the lowest runoff potentials, while Group D soils have the lowest infiltration rates and (highest runoff potentials).

**Hydrology** -----Study of properties, distribution, and circulation of water on the surface of the land as well as underground.

**Hydrophytic Vegetation** -----Plants adapted to life in wet environments.

**Hydroseeding** -----Application of seed and soil amendments (sometimes with a paper mulch) to an area to be stabilized by spraying it in a water mixture onto previously prepared soil (seedbed).

**Hydrostatic Head** -----A measure of pressure at a given point in water in terms of the vertical height of a column of water which would produce the same pressure.

**Hydrostatic Water Testing** -----High pressure water testing of pipelines (intended for gas or other product transport) to check for possible leaks.

**Hyetograph** -----A chart showing the distribution of rainfall over a particular period of time or a particular geographic area.

**Hygroscopic** -----The ability to attract, absorb, and retain atmospheric moisture.



**I or i** -----The symbol for Rainfall Intensity used in the Rational Equation ( $Q = C I A$ ).

**IECA** -----International Erosion Control Association.

**Illuvial Material** -----Soil material, usually minerals and colloidal particles that is removed from the upper soil horizon to a lower one. These can form a hardpan.

**Impact Basin** -----A device used to dissipate the energy of flowing water to reduce its erosion potential. It generally uses baffles to accomplish this.

**Impermeable Material** -----A soil or material whose properties prevent movement of water through the material.

**Impervious Surface** -----Hard ground cover that prevents or retards the entry of water into the soil and increases runoff, such as asphalt, concrete, rooftops, etc.

**Implied Easement** -----An easement for the benefit of lots necessary to provide passage or provision of water supply or sewerage over land or buildings in a subdivision. The easement is specified in words, not dimensions, on a plan of subdivision

**Impoundment** -----1. A water body upstream of a structure such as a sediment basin, trap, or detention pond constructed for the purpose of holding water. 2. An artificial collection and storage area for water or wastewater confined by a dam, dike, floodgate, or other barrier.

**Improvements** -----Roadways, building, utilities, etc. built upon a tract of land.

**Incised Stream** ----- A stream in which scouring causes the channel to degrade or down-cut to a point where the stream is no longer connected to its floodplain.

**Inclinometer** -----A device used to measure the change in inclination, or tilt, of a casing in a borehole.

**Individual NPDES Permit** -----A construction permit issued separately due to concerns about a special protection watershed, potential for disturbing toxic materials, or a history of lack of compliance.

**Infiltration** -----The portion of rainfall or surface runoff that moves downward into the subsurface soil and rock.

**Infiltration Basin** -----An excavated area that impounds stormwater runoff and allows it to gradually infiltrate the subsoil beneath the basin floor.

**Infiltration Capacity** -----The maximum rate at which the soil, when in a given condition, can absorb falling rain or melting snow.

**Infiltration Rate** -----The maximum rate at which water can enter a soil under specified conditions.

**Infiltration Trenches** -----Shallow excavations that have been backfilled with a coarse stone media. The trench forms an underground reservoir that collects runoff and allows it to infiltrate into the subsoil.

**Inflow** -----Water that enters a BMP or other hydrologic system.

**Influent Stream** -----A stream above the water table that contributes to groundwater recharge.

**Infrared Photography** -----A type of aerial photography useful in detecting subtle geologic features like fracture traces, sinkholes, groundwater seepage, etc.

**Infrastructure** -----1. An underlying base or foundation, especially for an organization or system.  
2. The basic facilities, services, and installations needed for the functioning of a community or society, such as transportation and communications systems, water and power lines, sewer lines, etc.

**Initial Loss** -----The sum of interception and depression loss, excluding blind drainage.

**Initial Storage** -----In TR-55, it is that portion of precipitation required to satisfy interception by vegetation, the wetting of the soil surface, and depression storage.

**Inlet** -----A drainage passage, as to a culvert or storm sewer.

**Inlet Control** -----In culverts, it is the condition when the culvert barrel is capable of conveying more flow than the inlet will accept.

**Inlet Filter Bag** -----A geotextile bag designed to fit inside a storm sewer inlet for the purpose of filtering sediment from runoff entering the inlet. See Standard Construction Detail #s 4-15 and 4-16.

**Inlet Protection** -----Type of BMP used at storm sewer inlets to prevent sediment from entering the inlets.

**Inoculation** -----The process of adding cultures of symbiotic micro-organisms to legume seed to enhance atmospheric nitrogen fixation.

**Inorganic** -----Composed of matter other than of plant or animal origin.

**Instantaneous Discharge** -----A discharge at a given moment.

**Intake** -----The inlet of a pipe, hose or channel conveying water from a stream or body of water.

**Intake Structure**-----A headwall, ditch, conduit, etc. used as an intake. A GP-4 is required.

**Intensity** -----The rate of rainfall typically given in inches per hour.

**Interception** -----In runoff calculations, the process by which precipitation is captured on the surfaces of vegetation and other impervious surfaces and evaporates before it reaches the land surface.

**Interceptor Channel** -----Now called a collector. See Chapter 6. A channel constructed for the purpose of collecting runoff from a disturbed area and transporting it to a sediment removal facility, such as a sediment basin or trap.

**Interceptor Dike** -----Now called a collector. See Chapter 6. A low berm constructed for the purpose of collecting runoff from a disturbed area and transporting it to a sediment removal facility.

**Interflow** -----Infiltrated subsurface water that travels to a stream without percolating down to the water table.

**Interim Stabilization** -----1. Temporary measures, such as mulching, used to stabilize a disturbed area until more permanent BMPs can be installed or while plan deficiency or permit issues are resolved. 2. Temporary vegetative cover or mulching over a disturbed area to reduce the potential for accelerated erosion until earthwork resumes or permanent stabilization is provided.

**Intermittent Stream** -----A body of water flowing in a channel or bed composed primarily of substrates associated with flowing water, which, during periods of the year, is below the local water table and obtains its flow from both surface runoff and groundwater discharges.

**Internal Erosion (of a Dam)** -----See Piping.

**Interstitial Water** -----Subsurface water located in the pore spaces of rocks.

**Inundate** -----To cover with water, especially floodwaters.

**Invasive Plant** -----A plant that moves in and takes over an ecosystem to the detriment of other species.

**Inverse Condemnation** -----The legal process that may be initiated by a property owner to compel the payment of fair compensation when the owner's property has been taken or damaged for a public purpose.

**Invert Elevation** -----The elevation of the inside bottom of a pipe.

**IP** -----Individual Permit.

**ITPMP** -----Method of obtaining Latitude and Longitude by interpolation of USGS 7.5 minute quadrangle maps.

## J

**JD** -----Jurisdictional Determination.

**Jersey Barrier** -----A portable section of concrete wall typically used to separate opposing lanes of traffic on highways, but occasionally used to construct cofferdams.

**Jetting** -----A method of placing piles or sheeting by forcing water around and under to displace and lubricate the surrounding soil, allowing the pile or sheeting to sink to the desired position.

**Jetty** -----A structure extending into a water body to restrain currents.

**Joint** -----A fracture plane in bedrock along which no movement has taken place.

**Joint Permit** -----A waterways obstruction or encroachment permit that satisfies both state and federal permit requirements.

**JPA** -----Joint Permit Application.

**Junction Boxes** -----Formed control structures used to join sections of storm drains.

**Jurisdictional Dam** -----A dam regulated by the PADEP.

**Jurisdictional Determination** -----Action by a regulatory agency to determine whether a regulated water body is present at a specific location.

**Jurisdictional Wetland** -----An area that meets the criteria established by the 1987 Corps of Engineers Wetlands Delineation Manual.

**Jute** -----A type of erosion control blanket made from natural fibers manufactured in an open weave.

# K

**k** -----The Hydraulic conductivity of soil

**K Factor** -----The soil erosion factor used for determining the level of potential erosion based upon soil characteristics.

**Kame** -----An irregular, short ridge or hill of stratified glacial drift.

**Karst** -----Areas with topography peculiar to and dependent upon underground solution of limestone and dolomite with the resultant formation of fissures, sinkholes, underground streams, and caverns.

**Key** -----The portion of bank protection that is placed in a trench excavated approximately 5 feet into the bank at the upstream and downstream ends of a project.

**Key Trench** -----Also known as Cutoff Trench, a trench cut along the center line of a sediment basin or detention pond earthen embankment that is filled with compacted clay to retard seepage under the embankment and reduce the potential for piping. See Standard Construction Detail #s 7-4 and 7-6.

**Keyway** -----1. A notch excavated into the side of a gully or channel to anchor a check dam or other structure. 2. A key trench.

# L

**Lacustrine** -----Pertaining to, produced by, or inhabiting a lake.

**Lagging** -----Heavy planking used to construct walls in excavations and braced cuts.

**Laminar Flow** -----The type of water flow where the individual particles of water move in parallel layers, typically at a relatively slow velocity. Also called subcritical flow.

**Land Use Plan** -----The process of inventorying and assessing the status, potentials, and limitations of a particular geographic area and its resources.

**Landing Area** -----In timber harvesting, the place where logs are temporarily stored until they are loaded onto trucks.

**Landslide** -----The failure of a slope in which the movement of the soil mass takes place along a surface of sliding.

**Large MS4** -----A municipal separate storm sewer system located in an incorporated municipality with a population of 250,000 or more, as determined by the 1990 U.S. Census.

**Lateral Sewers** -----Pipes that run under city streets and receive the sewage from homes and businesses, as opposed to domestic feeders and main trunks.

**Lateral Support** -----In slope stability analysis, it is the forces resisting movement due to the presence of material adjacent to the slope in question. Removal of this material could result in the destabilization of the slope.

**Launching** -----Stockpiling of stone along the top of a stream bank so that as the bank is undercut, the stone slides down slope, protecting the bank from future erosion.

**Layering, Soil** -----An undesirable stratification of a soil.

**Leachate** -----A liquid that has percolated through a landfill, mine, or other disturbed area and has picked up dissolved, suspended, and/or microbial contaminants from the waste.

**Leaching** -----The removal of materials in solution by the passage of water through the soil.

**Left Bank** -----The left-hand bank of a stream viewed when the observer faces downstream.

**Legume** -----Any member of the pea or pulse family which includes peas, beans, peanuts, clovers, alfalfas, sweet clovers, lespedezas, vetches, black locust, and kudzu. Practically all legumes are nitrogen-fixing plants.

**Levee** -----A natural or man-made earthen obstruction along the edge of a stream, lake, or river. If built of concrete or masonry, it is usually referred to as a flood wall.

**Level Spreader** -----An earthen or mechanical structure constructed at the discharge end of a diversion channel or dike to spread out the discharge over a low gradient, well-vegetated area.  
Mechanical level spreaders are sometimes used to diffuse the discharge from a basin or trap before it enters a wetland or riparian buffer.

**Licensed Professional** -----Professional engineers, landscape architects, geologists and land surveyors licensed to practice in this Commonwealth.

**Lifts** -----Layers of loose soil. This term is used to specify how much loose soil should be laid down at a time before it must be compacted or wrapped in geotextile fabrics.

**Lime** -----Calcium oxide (CaO) used in many water and wastewater treatment operations. Also called Quicklime.

**Limestone** -----A sedimentary rock composed of calcium carbonate (CaCO<sub>3</sub>).

**Limit of Disturbance** -----The boundary within which it is anticipated that earthmoving, including installation of BMPs, will take place.

**Limiting Exposed Areas** -----1. Minimizing the area to be disturbed by proposed earthmoving.  
2. Minimizing the time period from initial disturbance to final stabilization.

**Limnetic** -----1. Relating to or inhabiting the open water part of a freshwater body with a depth that light penetrates. 2. The area of a wetland without emergent vegetation.

**Liquid Limit** -----The moisture content at which soil passes from a plastic to a liquid state.

**Liquifaction, Spontaneous** -----The sudden large decrease in shear strength of a cohesionless soil due to a collapse of the structure from shock or other type of strain usually associated with a sudden but temporary increase in pore-fluid pressure. It involves the temporary transformation of the material into a fluid mass.

**Littoral** -----1. Of or pertaining to a shore, especially of the ocean. 2. The shoreward zone of a lake or wetland; the area where water is shallow enough for emergent vegetation to dominate.

**Littoral Drift** -----Sedimentary material moved along a shoreline due to the influence of waves and currents.

**Littoral Transport** -----The movement of littoral drift along the shoreline by waves and currents. This includes movement parallel — longshore transport — and perpendicular — on-offshore transport — to the shore.

**Live Staking** -----A bioengineering technique in which cuttings from living branches are inserted and tamped into the ground, where they eventually take root.

**Load** -----The amount of material being transported by a moving body of water.

**Loading** -----The quantity of a contaminant entering a water body.

**Loading Capacity** -----The greatest amount of a contaminant that can be added to a water body without exceeding water quality limitations established for that water body.

**Loam** -----An easily crumbled soil consisting of a mixture of clay, silt, and sand.

**Location Map** -----Map insert on plan drawings and in the narrative showing the location of the project.  
A photocopy of the USGS quad with the project outlined and the quad name provided is recommended.

**Loess** -----Deposits of silt laid down by wind action.

**Long Term Operation and Maintenance**-----The routine inspection, maintenance, repair or replacement of a BMP to ensure proper function for the duration of time that the BMP is needed.

**Longitudinal Profile** ----- A section of a stream, channel, pipe system, etc. along the length of its centerline.

**Longshore** -----Parallel to and near the shoreline.

**Losing Stream** -----A stream or reach of a stream that is losing quantity of flow due to seepage into the ground.

**Low Flow Channel** -----A stabilized channel constructed across the bottom of a detention basin or near the center of a larger channel for conveying base flow.

**Lower Bank** -----Portion of the stream bank below the normal flow level.

# M

**Main** -----Large sewer at which all other branches terminate.

**Maintenance** -----The regular inspection of BMPs to ensure proper functioning and timely repairs to damaged BMPs.

**Maintenance Dredging** -----Dredging conducted as part of the construction of a dam, water obstruction, or encroachment and periodic dredging conducted in order to:

1. Maintain adequate depths for navigation
2. Assure proper passage of ice and flood flows, or
3. Preserve the safety, stability, and proper operation of the facility.

**Major Modification to an NPDES Permit** -----An application that will modify an existing permit, which could include such activities as: enlarging the permit boundaries, expanding the total disturbed area, adding a new or increased point source discharge, adding a receiving surface water, etc.

**Manhole** ----- An access to an underground structure, such as a storm sewer.

**Manning's Equation** -----An empirical formula for computing flow in open channels and pipes.

$$V = \frac{1.49}{n} R^{2/3} S^{1/2}$$

where: V = velocity (fps)  
R = hydraulic radius (ft)  
S = channel bed slope (ft/ft)  
n = roughness coefficient

**Manning's "n"** -----The roughness coefficient used in Manning's equation for estimating channel flow — it is dimensionless.

**Marl** -----An earthy substance containing 35 to 65% clay and 65 to 35% carbonate formed under marine or freshwater conditions.

**Marsh** -----1. An area of soft, wet, or periodically submerged land, generally treeless and usually characterized by grasses and other low vegetation. 2. A wetland dominated by herbaceous emergent plants.

**Mattress** ----- A blanket or revetment of materials interwoven or otherwise tied together so as to provide a protective cover to an area subject to erosion.

**Maximum Design Water Elevation** -----The highest water level that can be obtained in an impoundment or water conveyance structure without encroaching on the required freeboard.

**Maximum Permissible Velocity** -----The highest velocity at which water may be carried safely in a channel or other conduit.

**Maximum Tailwater** -----The flow condition at a pipe outfall where the depth of water below the pipe reaches an elevation above ½ the diameter of the pipe.

**Mean Depth** -----The average depth; cross-sectional area of a stream or channel divided by its surface or top width.

**Mean Sea Level (MSL)** -----The level of the surface of the sea between mean high and mean low tide, used as a reference point for measuring elevations.

**Mean Velocity** -----The average velocity of water flowing in a stream or constructed channel at a given cross-section or in a given reach. It is equal to the discharge divided by the cross-sectional area of the reach.

**Meander** -----A loop-like bend in a stream channel.

**Meander Belt Width** -----The horizontal distance between the outside bends of two successive meanders measured perpendicular to the main flow direction.

**Meander Width Ratio** -----Meander belt width divided by bankfull width

**Mechanically Stabilized Earth** -----Use of steel bars or other material to stabilize the earthen mass behind a retaining wall.

**Median** -----The portion of a divided highway separating traffic traveling in opposite directions.

**Medium MS4** -----A municipal separate storm sewer system located in an incorporated municipality or county with a population of 100,000 or more but less than 250,000, as determined by the 1990 U.S. Census.

**Meltwater** -----Water that comes from melting ice or snow.



**Mesic** -----Refers to environmental conditions that have medium moisture supplies as compared to wet conditions — Hydric — or dry conditions — Xeric.

**Mesophyte** -----A plant that grows under medium conditions of moisture supply.

**MHW** -----Mean High Water

**Micron** -----A unit of length equal to 1 millionth of a meter and usually denoted by the symbol  $\mu$ .

**Microphytes** -----Microorganisms found in soil.

**Microscopic Soil Particles** -----Clay and silt; particles that cannot be observed individually by the unaided human eye.

**Mineral Soil** -----Soil that is mainly mineral material and low in organic material. Its bulk density is more than that of organic soil.

**Minimum Tailwater** -----The flow condition at a pipe outfall where the depth of water below the pipe reaches an elevation below  $\frac{1}{2}$  the diameter of the pipe.

**Minor Amendment to NPDES Permit** -----A change to the permit that does not require the permit to be re-advertised in the Pennsylvania Bulletin. For example, the addition of another rock construction entrance to the E&S Plans).

**Minor Drainage System** -----The drainage system consisting of street gutters, storm sewers, small open channels, and swales, etc.

**Minor Fill in Wetland** -----A permanent or temporary fill which is an integral part of the construction of a residence and driveway located in wetlands with the total surface of disturbed area not exceeding 0.1 acre.

**Minor Road Crossing** -----1. A small roadway across a wetland that individually impacts < 0.10 acre of wetland or cumulatively impacts < 0.25 acre of wetland. 2. A small stream crossing having a watershed drainage area  $\leq$  1.0 square mile. A GP-7 is required.

**Mitered End (a.k.a. beveled end)** -----A culvert end, the face of which conforms roughly with the face of the embankment slope.

**Mitigation Plan** -----1. Measures taken to reduce adverse effects on the environment. 2. A plan that decreases the severity of adverse effects on the site of historic resources.

**MLW** -----Mean Low Water.

**MOA** -----Memorandum of Agreement, a legal agreement between two agencies regarding certain duties or responsibilities.

**Moraine** -----An accumulation of earth, stones, and other debris deposited by a glacier. Some types are terminal, lateral, medial, and ground.

**Mottled** -----A soil characteristic denoting spots or blotches of different color.

**MOU** -----Memorandum of Understanding, essentially the same as an MOA.

**MS4** -----Municipal separate storm sewer system.

**Muck** -----Dark colored, finely divided, well-decomposed organic soil material.

**Mud Line** -----The lower surface of an excavation or braced cut.

**Mulch** -----A natural or artificial layer of plant residue or other materials placed on the soil surface to protect seeds, prevent blowing, retain soil moisture, curtail erosion, aid in establishing plant cover, and minimize soil temperature fluctuations.

**Mulch Binder** -----A substance sprayed over a mulched surface to hold the mulch in place, and often used on steep slopes or in areas subject to wind gusts.

**Municipal Notification** -----A written notice (required by Acts 67, 68, and 127) to local governments informing them of planned land development activities and providing them an opportunity to identify any land use planning or zoning ordinance conflicts associated with the proposed project before the Department or county conservation district completes its review of the application.

**Municipal Separate Storm Sewer System (MS4)**----- A publically owned conveyance or system of conveyances that discharge to waters of the US and is designed or used for collecting or conveying stormwater, is not a combined sewer, and is not part of a publically owned treatment works (POTW).

**Municipality** -----A county, city, borough, town, township, school district, institution or authority or another public body created by or pursuant to state law. For purposes of this definition, town includes an incorporated town.

**Munsell Chart** -----A standardized listing of soil colors according to hue, value, and chroma.

**Mycorrhizae** -----Fungi in soil; beneficial mycorrhizae in the root systems of plants help plants withstand extreme temperatures and increase their capacity to acquire nutrients.

**μ** -----Micron (one-millionth of a meter).

# N

**n** -----The symbol for Manning's roughness coefficient.

**NAD27** -----North American Datum of 1927 (at type of horizontal reference datum for latitude and longitude)

**NAD83** -----North American Datum of 1983

**Narrative** -----The part of an E&S plan which contains the applicant and plan designer information, soil use limitations and resolutions, wetland identification and delineation information, supporting calculations, stream classification information and any other pertinent data not required to be on the plan drawings.

**National Oceanic and Atmospheric Administration (NOAA)** -----A federal agency that oversees geographic, atmospheric, oceanic, and meteorological activities.

**National Wetlands Inventory** -----An effort by the U.S. Fish and Wildlife Service to map all the wetlands of the United States using aerial photography. NOTE: Many existing wetlands were missed during this process. Therefore, a negative determination based upon the maps produced by the NWI is insufficient evidence that no wetlands exist at a specific location.

**Native Species** -----A species that is part of an area's original flora or fauna.

**Natural Drainage** -----The flow patterns of stormwater runoff over land before development.

**Natural Stream Channel Design** -----A fluvial, geomorphic-based restoration method that uses data collection, modeling techniques, and stable or reference channels in the design of ideal channel configurations.

**Nature Conservancy** -----An international conservation organization dedicated to preserving plants and animals in their natural communities, often through purchase of land.

**NAVD 88**-----North American Vertical Datum of 1988.

**Navigable Streams** -----1. Waterways of sufficient depth and width to handle a specified traffic load.  
2. Legally, it is any stream so designated by the legislature.

**Neap Tide** -----A tide having about 10 to 30% less range than the average, occurring about the time of quarter moons.

**NEPA** -----National Environmental Policy Act, 1970; requires all federal agencies to incorporate environmental considerations into their decision-making processes and requires an Environmental Impact Statement for any "major federal action significantly affecting the quality of the human environment."

**Net Rain** -----That portion of rain that contributes to surface runoff.

**Netting** -----1. A mechanical method of anchoring straw or hay mulch by use of a staked net covering the mulch. Nets are typically made of nylon. 2. A heavy-weight woven material, typically jute or excelsior, used in place of mulch.

**Neutralization** -----The addition of an acid or base to a solution to achieve a pH of 7.

**New NPDES Permit Application** -----An application for a project that has not been previously permitted or for which the previous permit has expired.

**NFSAM** -----National Food Security Act Manual, the document used by NRCS for guidance in making wetland determinations on agricultural lands.

**NHPA** -----National Historic and Preservation Act.

**Nitrates** -----One form of nitrogen that plants can take up through their roots and use for growth (NO<sub>3</sub>).

**Nitrogen Fixation** -----The formation of nitrogen compounds (NH<sub>3</sub>, organic nitrogen) from free atmospheric nitrogen (N<sub>2</sub>).

**NGVD 29**-----National Geodetic Vertical Datum of 1929 — relating to bench marks.

**No Till Farming** -----Planting crops without prior seedbed preparation into an existing cover crop, sod, or crop residues, and eliminating subsequent tillage operations.

**NO<sub>3</sub>** -----Nitrate.

**NOAA** -----National Oceanic and Atmospheric Administration.

**NOI** -----Notice of Intent

**Nominal Size** -----The order size for a material — the actual size typically varies from the nominal size.

**Nomograph** -----A graph that can be used to determine an unknown value from one or more known values.

**Noncohesive Soil** -----Soil having particles that have no natural resistance to being pulled apart at their point of contact, such as silt, sand, and gravel.

**Nondischarge Alternative** -----Environmentally-sound and cost-effective BMPs that individually or collectively eliminate the net change in stormwater volume, rate and quality for storm events up to and including the 2-year/24-hour storm when compared to the stormwater rate, volume and quality prior to the earth disturbance activities to maintain and protect the existing quality of the receiving surface waters of this Commonwealth.

**Nonpathogenic** -----Not capable of causing disease.

**Non-Point Source Pollution** -----Pollution originating from diffuse sources.

**Nonstructural BMP** -----A method of protecting receiving surface water quality that does not require construction.

**Normal Depth** -----The depth of uniform flow.

**Normal Flow Depth** -----The depth of flow in an open conduit during uniform flow for a given set of conditions.

**Normal Pool** -----Design water surface elevation in a basin, trap, pond, or dam.

**Normal Pool Elevation** -----1. For bodies of water that have no structural measures to regulate height of water, the height of water at ordinary stages of low water unaffected by drought. 2. For structurally regulated bodies of water, the elevation of the spillway, outlet control, or dam crest which maintains the body of water at a specified height. 3. The term does not apply to wetlands.

**Normal Water Level** -----The average summer water level. The free surface associated with flow in natural streams.

**Normally Consolidated Soil** -----Soil that has never been consolidated by a greater stress than presently existing.

**North American Vertical Datum Plane** -----The elevation datum currently used by FEMA for determination of flood elevations.

**NOT** -----Notice of Termination

**Notch** -----The opening in a dam or spillway for the passage of water.

**Notice of Intent** ----- A request, on a form provided by the Department, for coverage under a General NPDES Permit for Stormwater Discharges Associated with Construction Activities or an E&S Permit.

**Notice of Termination** -----A request, on a form provided by the Department, to terminate coverage under a General or Individual NPDES Permit for Stormwater Discharges Associated with Construction Activities or other permits under Chapter 102.

**Nourishment** -----The process of replenishing a beach, either naturally through accretion due to the longshore transport, or artificially through the deposition of dredged materials.

**NOV** -----Notice of violation. An official letter from a Conservation district or DEP to an earthmover notifying him/her that one or more significant violations exist at a specific project site.

**Noxious Plant** -----A harmful plant species.

**Noxious Weed** -----A plant species having one or more of the following attributes: aggressive and difficult to manage, poisonous, toxic, parasitic, a carrier or host of serious insect or disease and being native or new to or not common to the U.S. or parts thereof.

**NPDES** -----National Pollutant Discharge Elimination System - The national system for the issuance of permits under s33 U.S.C.A. § 1342 including a state or interstate program that has been approved in whole or in part by the EPA, including the regulations codified in Chapter 92a (relating to National Pollution Discharge Elimination System Permitting, Monitoring and Compliance), and as specified in Chapter 102 ( relating to Erosion and Sediment Control).

**NPDES Permit for Stormwater Discharges Associated With Construction Activities** -----A permit required for the discharge or potential discharge of stormwater into waters of this Commonwealth from construction activities, including clearing and grubbing, grading and excavation activities involving 1 acre (0.4 hectares) or more of earth disturbance activity or an

earth disturbance activity on any portion, part, or during any stage of, a larger common plan of development or sale that involves 1 acre (0.4 hectares) or more of earth disturbance activity over the life of the project.

**NRCS** -----Natural Resources Conservation Service, formerly known as SCS, a federal agency under the U.S. Department of Agriculture which, among other things, provides technical assistance to conservation districts, assists farmers in developing conservation plans, provides soil survey information, and assists local governments in planning and installation of erosion and flood control projects.

**NRDC** -----Natural Resources Defense Council, a private American environmental organization emphasizing the proper management of natural resources.

**Nutrients** -----1. Mineral elements, such as nitrogen, phosphorus, or potassium, that are necessary for the growth and reproduction of organisms. 2. In water, those substances that promote growth of algae and bacteria, chiefly nitrates and phosphates.

**Nutrient Management** -----Proper use of control measures and BMPs during to application of soil amendments to agricultural lands so that the soil amendments are not carried by runoff into surface waters.

**NWI** -----National Wetlands Inventory.

**NWP** -----Federal Nationwide Permit.

**NWS** -----National Weather Service.



**Obligate Hydrophytes** -----Plant species found only in wetlands.

**Observation Well** -----A non-pumping well used to observe the elevation of the water table or the potentiometric surface. It is usually larger diameter than a piezometer and is typically screened or slotted throughout the thickness of the aquifer.

**Obstruction** -----Any structure or material in, along, across, or projecting into any watercourse that may alter, impede, retard or change the direction and/or velocity of the flow of water, or due to its location, its propensity to snare or collect debris carried by the flow, or its likelihood of being carried downstream.

**Ogee** -----A reverse curve shaped like an elongated letter S. The downstream faces of overflow dams are often made in this shape.

**Oil and Gas Activities** -----Earth disturbance associated with oil and gas exploration, production, processing, or treatment operations or transmission facilities.

**Oligotrophic** -----Nutrient-poor.

**On-Lot Controls** -----BMPs used during construction of the individual buildings of a housing project, industrial park, etc. They typically consist of a stabilized access, sediment barrier(s), and diversion channels — were necessary. On-lot controls should not be substituted for perimeter BMPs such as sediment basins and/or traps.

**On-lot Sewage System** -----A community and/or individual sewage system that uses a system of piping, tanks, or other facilities of r collecting, treating and disposing of sewage into a subsurface absorption area or a retaining tank.

**1-Hour Storm** -----A storm event having a duration of 1 hour.

**100-Year Flood** -----A flood having a one-percent chance of being equaled or exceeded in any given year.

**Open Channel** -----A natural or manmade structure that conveys water with the top surface in contact with the atmosphere.

**Open Channel Flow** -----Flow in an open conduit or channel that is driven by gravitational forces.

**Open Drain** ----- A natural watercourse or constructed open channel that conveys drainage water.

**Operator** -----A person who has one or more of the following: 1) Oversight responsibility of earth disturbance activity on a project site or a portion thereof who has the ability to make modifications to the E&S Plan, PCSM Plan or site specifications. 2) Day-to-day operational control over earth disturbance activity on all or part of a project site or a portion thereof to ensure compliance with the E&S Plan or PCSM.

**Organic Soil** -----Soil composed predominantly of organic rather than mineral material. Equivalent to Histosol.

**Organics** -----Particles of vegetation or other biologic material that can degrade water quality by decreasing dissolved oxygen and by releasing organic solutes during leaching.

**Orifice** -----An opening with a closed perimeter through which water may flow. It is usually sharp-edged, and of regular form in a plate, wall, or partition.

**Orifice Flow** -----In a barrel/riser type spillway, it refers to either:  
 1) Water entering the riser through perforations in the riser.  
 2) Water entering the top of the riser when the water level has reached a certain elevation above the riser.

**OSHA** -----Occupational Safety and Health Administration (U.S. Dept. of Labor).

**Outcrop** -----Surface exposure of bedrock.

**Outfall** -----The point where water flows from a pipe, conduit, channel, etc.

**Outfall Structure** -----An endwall, splash pad, riprap apron, ditch, conduit, diffuser, or diversion used as an outfall. An authorization is required.

**Outlet** -----The point of water disposal from a stream, river, lake, tidewater, or artificial drain.

**Outlet Basin** -----Outlet protection for a barrel/riser type sediment trap or a temporary slope pipe conveying clean water. See Standard Construction Detail 8-6.

**Outlet Channel** -----A suitably sized and protected channel for the purpose of conveying the discharge from a culvert, pipe, or impoundment to the receiving waters.

**Outlet Control** -----In culverts, it is the condition where the culvert barrel is not capable of conveying as much flow as the inlet will accept.

**Outlet Protection** -----An apron, dissipater, basin, or other device placed below a pipe or channel outfall to prevent scour.

**Outslope** -----The exposed area sloping away from the top of a fill or bench.

**Overbank Drainage** -----Water flow over top of the bank and down the slope.

**Overbank Flow** -----Water flow over the top of the bankfull channel onto the floodplain.

**Overburden** -----The earth, rock, and other materials that lie above a coal or mineral deposit.

**Overland Flow** -----Also called sheet flow. In determining travel time ( $T_c$ ), it is the flow regime before shallow concentrated flow.

**Overseeding** -----Seeding into a dormant turf with cool season grasses in order to provide a playable surface, as on a golf course, during winter months, or for aesthetics.

**Overstory** -----The uppermost part of a plant community.

**Overtopping** -----The passing of water over the top of a natural or artificial structure as a result of wave action or surging.

**Owner** ----- A person who holds legal title to the land subject to construction activity. This term also includes the person(s) who held legal title to the land subject to construction activity at the time such activity was commenced on a site.

**Oxbow** -----An abandoned meander in a river or stream system.

**Oxidation** -----The chemical process in which electrons are removed from an atom, ion, or compound. Oxidation always occurs as part of an oxidation-reduction reaction.

# P

**P** -----Symbol for wetted perimeter - In a channel, it is the length of the boundary between the water and the channel sides and bottom.

**PA DCNR Bureau of Forestry** -----The state agency responsible for the protection of over 2 million acres of forest land in the Commonwealth from forest fire, insects and disease.

**PA DCNR Bureau of Topographic and Geologic Survey** -----Plans, administers, and conducts comprehensive and detailed surveys of the geology, mineral resources, topography and ground water resources of PA.

**PA DEP Bureau of Safe Drinking Water** -----The state agency responsible for setting drinking water standards..

**PA DEP Bureau of Clean Water** ---- The state agency responsible for administering the NPDES program for discharges of sewage, industrial, municipal, and construction stormwater, industrial wastewater, the application of pesticides, and the operation of Concentrated Animal Feeding Operations.

**PA DEP Bureau of Watershed Restoration and Nonpoint Source Management** -----The state agency responsible for conservation district support and the nutrient management program.

**PA DEP Bureau of Waterways Engineering and Wetlands** -----The state agency responsible for dam safety and the water obstructions and encroachments program.

**PA Fish and Boat Commission** -----A state agency responsible for technical assistance and supervision in carrying out fish and aquatic life activities and enforcement of fish and boat laws.

**PA Historical and Museum Commission**, State agency responsible for preserving significant historical structures and archaeological sites.

**PA Natural Diversity Inventory** -----A data bank of site locations where species listed on the PA Threatened and Endangered Species list have been identified.

**PA State Programmatic General Permits** -----Permits that authorize certain minimal impacts to waters of the United States within the boundaries of Pennsylvania as required by the federal Clean Water Act 33 U.S.C.A. §§ 1251—1376.

**PA Wetland Replacement Project** -----A fund managed by the National Fish and Wildlife Foundation. Money from the fund is dispersed at the direction of the DEP, to which Chapter 105 permit applicants can make a monetary contribution, instead of creating wetlands.

**PADEP** -----The PA Department of Environmental Protection.

**Palisade** -----Barrier.

**Palustrine** -----Pertaining to a marsh or wetland.

**Palustrine Wetlands** -----Wetlands dominated by trees, shrubs, herbaceous plants, mosses or lichens.

**PAM** -----Polyacrylamide

**Parabolic Channel** -----A channel having a parabola-shaped bottom and sides when viewed in cross-section.

**Parent Material** -----The unconsolidated and more or less chemically weathered material from which a soil has been derived.

**Parshall Flume** -----A device used to measure the flow of water in an open channel.

**Particulate Matter** -----Solid material in water; either in the solid or dissolved state.

**PASPGP-3** -----Pennsylvania State Programmatic General Permit-3,

**PCBs** -----Polychlorinated biphenyls.

**PCSM** -----Post construction stormwater management.

**PCSM Plan** -----A site-specific plan consisting of both drawings and a narrative that identifies BMPs to manage changes in stormwater runoff volume, rate and water quality after earth disturbance activities have ended and the project site is permanently stabilized.

**Pathogenic** -----Capable of causing disease.

**Peak Discharge** -----The maximum design flow rate at which runoff from a drainage area discharges past a specific point.

**Peak Flow** -----The maximum instantaneous discharge of a stream or river at a given location.

**Peat** -----Unconsolidated material, largely of undecomposed organic matter, that has accumulated under excess moisture.

**Ped** -----An individual natural soil aggregate, such as a granule, a prism, or a block.

**PennDOT (PA DOT)** -----The state agency responsible for administering the state's transportation system, the stabilization of road banks, storm water drainage from existing roadways and control of erosion and sediment pollution from new highway construction.

**PennDOT Publication 408** -----The Pennsylvania Department of Transportation's book of specifications.

**Pennsylvania Natural Diversity Inventory (PNDI)** -----A listing of the locations of threatened or endangered species and/or their habitats. Earthmoving projects that could potentially impact such areas must resolve these conflicts with the appropriate agency before an NPDES permit can be authorized.

**Percolation** -----The movement of water through soil.

**Percolation Rate** -----The rate, typically expressed in inches/hour or inches/day, at which water moves through the soil profile.

**Percolation Test** -----A measure of the rate of percolation or seepage of water through a soil expressed as time for a 1” fall of water in a test hole.

**Perennial Vegetation** -----Vegetation that lives for more than one growing season.

**Perennial Stream** -----A body of water flowing in a channel or bed composed primarily of substrates associated with flowing waters and capable, in the absence of pollution or other manmade stream disturbances, of supporting a benthic macro-invertebrate community which is composed of two or more recognizable taxonomic groups of organisms that are large enough to be seen by the unaided eye and can be retained by a United States Standard No. 30 sieve — 28 meshes per inch, 0.595 mm openings — and live at least part of their life cycles within or upon available substrates in a body of water or water transport system.

**Perimeter BMPs** -----Those BMPs that will be installed at or near the project boundaries to prevent runoff from entering the disturbed area or to capture and treat runoff from disturbed areas prior to leaving the site.

**Permanent Pool** -----The area within a sediment basin that is designed to be inundated with water at all times. For barrel/riser spillways, it is the storage area below the lowest row of perforations; for a skimmer, it is the area below the lowest elevation to which the skimmer dewateres the basin.

**Permanent Riser** -----In a detention pond being used temporarily as a sediment basin, it is the part of the principal spillway riser system, usually a concrete riser, which will remain when the temporary riser, or skimmer, is removed. See Standard Construction Detail #7-9.

**Permanent Stabilization** -----Long-term protection of soil and water resources from accelerated erosion.

**Permanent Vegetation** -----Perennial vegetation that has been established to provide permanent stabilization.

**Permeability** -----The ability of a medium, such as soil, to allow fluids, such as water, to pass through.

**Permeability Coefficient** -----The rate of flow of water in gallons/day through a section of 1 square foot under a unit hydrologic gradient.

**Permeability Rate** -----The rate at which water will move through a saturated soil. Permeability rates are classified as follows:

<b>Very Slow:</b>	< 0.06	in/hr.
<b>Slow:</b>	0.06 to 0.20	in/hr.
<b>Moderately Slow:</b>	0.20 to 0.63	in/hr.
<b>Moderate:</b>	0.63 to 2.0	in/hr.
<b>Moderately Rapid:</b>	2.0 to 6.3	in/hr.
<b>Rapid:</b>	6.3 to 20.0	in/hr.
<b>Very Rapid:</b>	> 20.0	in/hr.

**Permissible Shear Stress** -----The force required to initiate movement of a channel bed or lining material.

**Permissible Velocity** -----The highest velocity at which water may be carried safely in a channel or other conduit.

**Permit Boundary** -----The limits of a project site upon which an NPDES permit is based. They should include all areas that may be disturbed over the life of the project.

**Permitted Activity** -----Any activity requiring a DEP-issued permit, approval, or authorization.

**Permittee** -----A person who has a permit, approval, or authorization which DEP is authorized to issue under any of the environmental statutes that DEP implements.

**Person** -----Any operator, individual, public or private corporation, partnership, association, municipality or political subdivision of this Commonwealth, institution, authority, firm, trust, estate, receiver, guardian, personal representative, successor, joint venture, joint stock company, fiduciary; Department, agency or instrumentality of State, Federal or local government, or an agent or employee thereof; or any other legal entity..

**Pervious** -----Allowing the movement of water.

**PFBC** -----PA Fish and Boat Commission.

**pH** -----A measure of the acidity or alkalinity — hydrogen ion concentration — of water or soil. pHs below 7.0 are acidic, while those above 7.0 are alkaline.

**Phased Construction** -----An earth disturbance activity that takes place in discreet stages. One or more phases may be active at any time during active construction. A separate construction sequence is typically developed for each phase. Any phase not included in the initial application must be submitted to the appropriate reviewing authority and approved in writing prior to any earth disturbance, including clearing and grubbing, within that phase.

**Phase II** ----- Final Rule published in the Federal Register on December 8, 1999, requiring NPDES permit coverage for storm water discharges from certain MS4s and from Construction Activity between 1 and 5 acres.

**Phasing Construction** -----The breaking up of a project into smaller units which will be constructed one or two at a time.

**PHMC** -----Pennsylvania Historical and Museum Commission.

**Phosphates** -----An important nutrient for plant growth ( $PO_4$ ).

**Photodegradable** -----Materials that are not resistant to ultraviolet radiation and therefore break down relatively quickly when exposed to sunlight.

**Phreatic Line** -----1. The line marking the upper surface of the zone of saturation in the soil. 2. In a basin embankment, it is the theoretical interface between the saturated zone and the unsaturated zone.

**Phreatic Zone** -----The layer below the water table down to an impervious layer.

**Physiographic Region** -----A large-scale unit of land having similar climate, geology, topography, and other physiographic features.

**Piezometer** -----A non-pumping well, generally of small diameter that is used to measure the elevation of the water table or potentiometric surface. A piezometer generally has a short well screen through which water can enter.

**Piezometer Nest** -----A set of two or more piezometers set close to each other but screened to different depths.

**Piezometric Level** -----The level to which water will rise in a pipe due to the water's own pressure.

**Pile** -----A long, heavy timber, pipe, or section of concrete or metal to be driven or jetted into the earth or seabed to serve as a support for a bulkhead.

**Pipe Flow** -----In sediment basin or trap discharge capacity calculations, it is the flow regime used to calculate the capacity of the outlet barrel.

**Piping** -----In sediment basins and traps it is the seepage of water through the embankment along the outside of the outlet barrel. If undetected and uncorrected, it could result in embankment failure.

**Plan Drawings** -----The drawings used by a contractor to construct a project. In E&S plans, these drawings include maps, construction details and typicals, sequencing, maintenance information, seeding and mulching specs, and any other information needed by the contractor to comply with the Department's rules and regulations.

**Plan Map** -----A topographic map that shows the proposed earthmoving and the BMPs that are to be used to control accelerated erosion and sedimentation during construction.

**Planimeter** -----A device used to measure the area of a drawn shape.

**Plant Community** -----All of the plant species and individuals occurring in a shared habitat or environment.

**Plasticity Index** -----The numerical difference between the liquid limit and the plastic limit of a soil; the range of moisture content within which the soil remains plastic.

**Plastic Limit** -----The moisture content at which a soil changes from a semi-solid to a plastic state.

**PLS** -----In seeding and mulching specifications, it refers to pure live seed.

**Plugging** -----Establishing turf grass using plugs of sod.

**Plume** -----A contaminated effluent added to a receiving stream near a point source.

**Plunge Pool** -----A small permanent pool at either the inlet to a BMP or at the outfall from a BMP. The primary purpose of the pool is to dissipate the velocity of stormwater runoff, but it can also provide some pretreatment.

**PNDI** -----Pennsylvania Natural Diversity Inventory.

**$PO_4$**  -----Phosphate.

**Point Bar** -----A sediment deposit that has accumulated on the inside of a bend in a stream channel.



**Pollutant** -----Any contaminant or other alteration of the physical, chemical, biological or radiological integrity of surface water which causes or has the potential to cause pollution as defined in section 1 of The Clean Streams Law (35 P.S. §§ 691.1—691.1001).

**Pollutant Loading** -----The arithmetic product of the pollutant concentration and the runoff rate.

**Pollution** -----Contamination of any surface waters such as will create or is likely to create a nuisance or to render such waters harmful, detrimental or injurious to public health, safety or welfare, or to domestic, municipal, commercial, industrial, agricultural, recreational, or other legitimate beneficial uses, or to livestock, wild animals, birds, fish or other aquatic life, including but not limited to such contamination by alteration of the physical, chemical or biological properties of such waters, or change in temperature, taste, color or odor thereof, or the discharge of any liquid, gaseous, radioactive, solid or other substances into such waters.

**Polyacrylamides (PAMs)** -----Synthetic polymers with extensive water-retention and water-saving capabilities used to halt erosion and promote vegetative growth. The polymers are long-lasting, gel-forming, water-absorbing materials that can absorb more than 400 times their weight in distilled water.

**Polypropylene** -----A synthetic — polymeric — material used in the making of geogrids, some compost socks, and other materials.

**Ponding** -----Standing water on soil in a closed depression.

**Pool Area** -----The location for storing water upstream of an embankment.

**Pore Water** -----See interstitial water.

**Porosity** -----The ratio of pore space to total volume of soil or rock. These pore spaces might or might not be interconnected.

**Post Construction Stormwater** -----Stormwater associated with a project site after the earth disturbance activity has been completed and the project site is permanently stabilized.

**Post Construction Stormwater Management Plan (PCSM Plan)** -----A site specific plan identifying BMPs to manage stormwater runoff after construction activities have ended and the project site permanently stabilized to protect and maintain existing and designated uses. The PCSMP must contain a written narrative, including calculations or measurements, and justifications for each BMP. The BMPs should be designed to maximize infiltration technologies, minimize point source discharges to surface waters, preserve the integrity of stream channels, and protect the physical, biological and chemical qualities of the receiving water.

**Potable Water Supply** -----1. Water that is drinkable; water that meets the standards in quality as established in the U.S. EPA's Drinking Water Standards. 2. A water supply that is used as public drinking water.

**Potential Sediment Pollution** -----Site conditions, such as a failure to install or maintain BMPs specified in the E&S Plan that if not corrected, could result in sediment pollution to surface waters if a design storm occurs.

**PPC Plan** ----- **Preparedness, Prevention and Contingency Plan** - A written plan that identifies an emergency response program, material and waste inventory, spill and leak prevention and response, inspection program, housekeeping program, security and external factors, and that is developed and implemented at the construction site to control potential discharges of pollutants other than sediment into waters of this Commonwealth.

**Pre-construction Meeting** -----A meeting held prior to initial disturbance on a construction site between the operator(s) and all interested agencies to facilitate communication between all parties.

**Preparedness, Prevention and Contingency Plan (PPC Plan)** -----A written plan that identifies an emergency response program, material and waste inventory, spill and leak prevention and response, inspection program, housekeeping program, security and external factors, developed and implemented at the construction site to control potential discharges of pollutants other than sediment into waters of this Commonwealth. Potential pollutants at construction activities can include, but are not limited to pesticides, fertilizers, lime, petrochemicals, construction-related chemicals and solvents, wastewater, wash water, core drilling wastewater, cement, sanitary wastes or hazardous wastes.

**Previous Land Uses** -----The actual land use(s) of an area of land for the past 50 years, or longer if known. Note: This is not just the zoning of the land.

**Previously Mined Area** -----1. Any area that has been subject to surface or underground mining activity, 2. A grayfield.

**Principal Spillway** -----The primary system used to dewater a sediment basin or dam at predetermined rates in a staged fashion.

**Proctor Curve** -----Curve showing the relationship between the density and water content of soil for a given compaction.

**Profile** -----A representation of an object or structure seen from the side along its length.

**Project Applicant** -----A person who has filed or intends to file an application for a permit, approval, or authorization that DEP is authorized to issue under any of the environmental statutes that DEP implements.

**Project Name** -----The name by which a project is or will be known.

**Project Site** -----The entire area of activity, development, lease, or sale including:

- (i) The area of an earth disturbance activity.
- (ii) The area planned for an earth disturbance activity.
- (iii) Other areas that are not subject to an earth disturbance activity.

**Protective Lining** -----Materials placed within a water conveyance or impoundment structure to prevent accelerated erosion.

**Public Comment Period** -----The time allotted for citizens to express views and concerns regarding an action proposed by a government agency, such as rulemaking, issuing permits. Etc.

**Pump-around System** -----A method of working within a watercourse wherein base flow is captured upstream of the work area and pumped to a suitable stabilized discharge point downstream of the work area.

**Pumped Water Filter Bag** -----A bag manufactured from filter fabric and used to filter water pumped from a disturbed area prior to discharging it to Surface waters.

**Pumping Test** -----A test that is conducted to determine aquifer or well characteristics, typically the change in hydraulic head while pumping over time.

**Pure Live Seed** -----The product of the percentage of pure seed times the percentage of germination divided by 100. For example, [85% pure seed X 72% germination rate] ÷ 100 = 61% PLS.

**Purveyor** -----Supplier.

**PVC** -----Polyvinyl Chloride, which is a type of plastic commonly used in pipe and some geotextiles.

**PWRP** -----PA Wetland Replacement Project.

**Pyrite** -----A yellowish mineral, iron disulfide, FeS<sub>2</sub>, generally metallic in appearance. Commonly referred to as fool's gold..

## Q

**Q** -----Symbol of quantity of flow, usually given in cfs.

**Quad Map** -----Topographic map of a 7 ½ minute quadrangle published by the USGS.

**Quadrangle** -----A 4-sided area, bounded by parallels of latitude and meridians of longitude used as an area unit of mapping, typically in 7 ½ minutes but sometimes in 15 or 30 minutes.

**Quicklime** -----See lime.

## R

**R, or r** -----Symbol for hydraulic radius.

**Rainfall Duration** -----The period of time during which rainfall occurs, exceeds a given intensity, or maintains a given intensity.

**Rainfall Frequency** -----The frequency, usually expressed in years, at which a given rainfall intensity and duration can be expected to be equaled or exceeded.

**Rainfall Intensity** -----In the Rational Equation, it is the rate of rainfall in inches per hour.

**Light Rain:** ≤ 0.10 in/hr.

**Moderate Rain:** 0.11 to 0.30 in/hr.

**Heavy Rain:** > 0.30 in/hr.

**Range** -----The geographic region in which a given plant or animal lives and grows.

**Rapid Drawdown** -----Lowering the elevation of water against a bank or wall faster than the structure can drain, leaving a pressure imbalance that may cause the bank or wall to fail.

**Rapid Flow** -----Flow at less than critical depth, typically occurring on steep slopes.

**Rare Species** -----A species of plant or animal that, although not presently threatened with extinction, is in such small numbers throughout its range that it may be endangered if its environment worsens.

**Rating Curve** -----A plot of quantity flowing versus depth for a natural watercourse.

**Rational Equation** -----One method of estimating the peak rate of flow that would occur during a design storm event. The equation is as follows:  $Q = C I A$ . It is not a very precise method for determining runoff volume.

**RC-70** -----Standard Construction Drawings used by PennDOT for their E&S plans.

**RCEP** -----Rolled erosion control product.

**RCRA** -----Resource Conservation Recovery Act; federal legislation requiring that hazardous wastes be tracked from general to disposal.

**Reach** -----Any specified length of a stream, channel or conveyance that typically have equal or very similar flow characteristics.

**Rebar** -----Reinforcement Bar — generally steel — primarily used to strengthen concrete.

**Receiving Watercourse** -----Any channel, stream, swale, wetland, or other body of water that could receive runoff from a project site.

**Recharge** -----1. The downward movement of water through soil to groundwater. 2. The process by which water is added to the zone of saturation.

**Recharge Zone** -----A land area into which water can infiltrate into an aquifer relatively easily.

**Record Drawing** -----see As Built

**Record of Decision** -----DEP document for recording consideration of alternatives when authorizing an encroachment upon a wetland.

**RECP** -----Rolled Erosion Control Product.

**Red Dog** ----- The material from a coal gob pile after it has been burned.

**Reference Reach** -----A section of a stream that provides a target for a river restoration project; a reference reach must be located within the same hydro-physiographic region, have the same general land use, and the same stream type and valley form as the proposed stream.

**Regulated Surface waters** -----Watercourses, streams, or bodies of water and their floodways wholly or partly within or forming part of the boundary of Pennsylvania.

**Reinforced Silt Fence (Reinforced Filter Fabric Fence)**-----30" high silt fence with mesh backing and guy wires, as shown in Standard Construction Detail #4-8, or with staked straw bale backing, as shown in Standard Construction Detail #4-9.

**Renewal** -----An application to renew an existing NPDES permit that is nearing expiration. This renewal should be submitted a minimum of 90 days prior to the expiration of a general permit and 180 days for an individual permit. Note: An expired permit cannot be renewed.

**Reno Mattress** -----A series of wire baskets, less than 12" high, tied together by the manufacturer. These baskets are filled with riprap and used to stabilize stream banks, hillsides, and other areas subject to flowing water with high velocities.

**Replacement Wetlands** -----Artificially created wetlands to replace those wetlands destroyed by construction.

**Required Discharge Capacity** -----The minimum flow rate at which an impoundment must discharge when the water level within the impoundment reaches the maximum design water elevation. For sediment basins it is 2 cfs/acre. For traps it is 1.5 cfs/acre.

**Required Storage Capacity** -----The storage volume necessary to provide sediment storage plus a suitably sized settling zone for a sediment basin or trap.

**Reservoir** -----A natural or artificial basin that contains or will contain the water or other fluid or semi-fluid impounded by a dam.

**Residual Soil** -----A soil that remains where it was formed.

**Resurfacing** -----A supplemental surface or replacement placed on an existing pavement to restore its riding qualities or increase its strength.

**Retaining Wall** -----A wall built to support or prevent the advance of a mass of earth or water.

**Retardance** -----In grass-lined channels, it is the resistance to flow due to the vegetative lining. The degree of vegetal retardance depends largely on the height and density of cover.

**Retention** -----That part of the precipitation falling on a drainage area that does not escape as surface streamflow.

**Retention Basin** -----A permanent lake or pond used to prevent stormwater runoff from leaving the development site. Storage for temporary periods is referred to a “detention.”

**Retrofit** -----The modification of stormwater management systems through the construction and/or enhancement of wet pond, wetland plantings, or other BMPs designed to improve water quality.

**Return Period** -----The arithmetic mean of time units, such as years, between observations of an event of a certain magnitude. For example, a storm event with a return period of 100 years is not expected to occur more often than once in 100 years.

**Revegetation** -----Reestablishing vegetative cover on ground that has been disturbed, such as a construction site.

**Revetment** -----1. A facing of stone, bags, blocks, pavement, etc. used to protect or armor a bank against erosion. 2. A retaining wall.

**Reynolds Number** -----A number defined by the equation  $R_e = 4rv/\nu$   
 Where:  $R_e$  = Reynolds number  
 $r$  = hydraulic radius  
 $v$  = velocity  
 $\nu$  = kinematic viscosity

The Reynolds number is used to determine whether a flow will be laminar or turbulent. Turbulent flow typically has a Reynolds number greater than 4000.

**Rhizome** -----A below-ground stem capable of growing horizontally and producing a new plant.

**Riffle** -----Shallow rapids in an open stream where the water surface is broken into waves by obstructions such as shoals or sandbars.

**Right Bank** -----The right-hand side of a stream, river, or channel when facing in the direction of flow.

**Right-of-Way** -----For highways, pipelines, and utility lines, it is the boundary line within which the contractor has a legal right to do earthwork.

**Rill Erosion** -----Removal of soil particles from an area due to surface runoff moving through relatively small channels — only a few inches deep.

**Riparian** -----Pertaining to the banks of a stream, river, waterway, or other flowing body of water as well as the plant and animal communities along such bodies of water.

**Riparian Buffer** ----- A BMP that is an area of permanent vegetation along surface waters.

**Riparian Corridor** -----A narrow strip of land centered on a stream that includes the floodplain as well as related habitats adjacent to the floodplain. Also called a riparian zone.

**Riparian Forest Buffer** ----- A type of riparian buffer that consists of permanent vegetation that is predominantly native trees, shrubs and forbs along surface waters that is maintained in a natural state or sustainably managed to protect and enhance water quality, stabilize stream channels and banks, and separate land use activities from surface waters.

**Riparian Rights** -----A principle of common law that requires any use of waters adjoining or flowing through his lands must so use and protect them so that he will enable his neighbor to utilize the same waters undiminished in quantity and undefiled in quality.

**Riparian Vegetation** -----Plants adapted to moist growing conditions found along waterways and shorelines.

**Riprap** -----Crushed stone that meets certain requirements for size gradation, weight, durability, and shape. It is generally specified according to “R” size.

**Riprap Apron** -----A type of outlet protection constructed out of riprap and with dimensions derived from Figure 9.3 or 9.4.

**Riser** -----That part of a barrel/riser type spillway which extends vertically from the bottom of the impoundment to the top of the settling zone. See Figure 7.1.

**River Training Works** -----Structures placed within a stream channel to direct the current into a predetermined course.

**Rivulet** -----A small stream or brook.

**Road Maintenance Activities** -----Earth disturbance activities within the existing road cross-section or railroad right-of-way including: shaping or re-stabilizing unpaved roads; shoulder grading; slope

stabilization; cutting of existing cut slopes; inlet and endwall cleaning; reshaping and cleaning drainage ditches and swales; pipe cleaning; pipe replacement; support activities incidental to resurfacing activities such as minor vertical adjustment to meet grade of resurfaced area; ballast cleaning; laying additional ballast; replacing ballast, ties and rails; and other similar activities. The existing road cross-section consists of the original graded area between the existing toes of fill slopes and tops of cut slopes on either side of the road and any associated drainage features.

- Roadbed** -----That portion of a roadway extending from curb line to curb line or from shoulder line to shoulder line. Divided highways are considered to have two roadbeds.
- Rock Chimney Drain** -----A comparatively small vertical extension of a rock toe bench maintained within a constructed earthen fill to facilitate drainage of surface runoff from the top of the fill into the rock toe bench. The purpose of this drainage is to prevent concentrated flows and the formation of erosion gullies on the outslope(s) of the fill and to remove some of the sediment load prior to discharge to receiving surface waters.
- Rock Construction Entrance** -----A method of stabilizing a temporary construction entrance to a project site from a paved roadway by placement of AASHTO #1 stone. See Standard Construction Detail #3-1.
- Rock Filter** -----A sediment barrier constructed from riprap and filter stone. See Standard Construction Detail # 4-14.
- Rock Filter Berm** -----A sediment barrier constructed across a right-of-way or below a disturbed area. Due to the cost of construction, this BMP should be used only where no other BMP is feasible.
- Rock Filter Outlet** -----A sediment barrier constructed at points where concentrated flow is anticipated at a silt fence or straw bale barrier or where concentrated flow has caused the failure of a barrier.
- Rock Toe Bench** -----An excavated and rock-filled structure constructed at the base of a fill where the foundation is located in water or in saturated or unstable soils to ensure proper drainage and support for the overlying earthen fill.
- Rock Vanes** -----Rock structures used in FGM-based restoration projects; slope and shape of the rock vane reduces the velocity of the water as it flows up the vane and accelerates the flow as it rolls water away from the bank towards the center of the stream; the net effect is to protect the bank from erosion and to direct the force of the water into the center of the stream for sediment transport.
- ROD** -----Record of decision.
- Rodent Gate** -----An appurtenance at the outlet end of a drainage pipe that swings outwards to permit flow and detritus to pass, yet prevents rodents and other animals from entering and potentially blocking the system.
- Rolled Erosion Control Products (RECPs)** -----Temporary, degradable or long-term, non-degradable material manufactured or fabricated into rolls and designed to be rolled out and staked onto an exposed surface to reduce soil erosion and promote the growth of protective vegetation.
- Root Zone** -----That part of a soil which can be penetrated by plant roots.
- Rooted** -----Expression indicating that a bank has been excavated and the end of a structure, such as a check dam, dike, etc., has been placed in the cavity, thus retarding future streamflow around the end of the structure — flanking.
- Rootwad** -----A tree stump with roots that are strategically placed in a stream bank as part of rebuilding or restoring the bank; it is typically used to control erosion on outside bends; rootwads are angled upstream with the root mass facing the flow; this serves to dissipate energy by receiving the brunt of the stream energy.
- Roughness** -----The resistance of streambed materials, vegetation, or liners to the flow of water in a channel or swale.
- Roughness Coefficient** -----A dimensionless value in Manning's Equation that varies depending upon the type of lining and flow depth.
- Routing** -----The process of transposing an inflow hydrograph through a structure and determining the outflow hydrograph from the structure.
- Rubble** -----Rough, irregular fragments of broken rock or concrete.
- Runoff** -----That portion of a rainfall or snowmelt that flows over the surface.

**Runoff Coefficient** -----In the Rational Equation, it is the factor chosen to reflect such watershed characteristics as topography, soil type, vegetation, and land use in estimating the fraction of total rainfall that will become surface runoff.

**Runoff Curve Number** -----In TR-55, it is a number used to represent the runoff potential of a specified area based on the hydrologic soil group, hydrologic condition, and type of cover.

**Runoff Event** ----- A precipitation event or snowmelt that produces runoff.

**Runoff Hydrology** -----An estimation of the amount of runoff or the peak flow that can be anticipated from a design storm.

**RUSLE** -----Revised universal soil loss equation.

# S

**S, or s** -----In channel calculations, it is the bed slope, typically expressed in ft/ft.

**Saltation** -----The movement of soil or rock particles by rolling or a series of short bounces along the ground due to wind, or a stream bottom by flowing water.

**Sand** -----1. Soil particles ranging from 0.05 to 2.0 mm in diameter; individual particles are visible to the unaided human eye. 2. A soil textural class inclusive of all soils which are at least 70% sand and 15% or less clay.

**Sand Filters** -----Filters that provide stormwater treatment when runoff is strained through a sand bed before being returned to a receiving surface water.

**Sandbar** -----A ridge of sand built up by currents, especially in a river or creek.

**Sandy Soil** -----A soil that is composed of at least 50% sand-sized particles.

**Sanitary Sewer** -----A utility line — typically underground — designed to convey wastewater from a developed area to a treatment facility.

**Saturated Soil** -----Soils in which all voids or pore spaces between soil particles are filled with water.

**Saturated Zone** -----In basin and pond embankments, it is that part of the embankment that is saturated due to the water impounded by the embankment.

**S<sub>c</sub>** -----In channel design, the symbol for critical slope, the slope at which unstable flow occurs within a given channel. .

**Scarified Seed** -----Seed which has been subjected to abrasive treatment to encourage germination.

**Scarify** -----To loosen or stir the surface soil without turning it over.

**Scarp** -----The nearly vertical, exposed earth surface created at the upper edge of a slide or a breached area along the upstream slope.

**Scenic River** -----Areas in or within 100 feet of a watercourse or body of water designated a component of the Pennsylvania Scenic Rivers System in accordance with the Pennsylvania Scenic Rivers Act.

**Scour** -----1. The erosive action of flowing water in streams that removes and carries away material from the bed and bank. 2. Erosion at the outfall of a pipe or channel.

**Scour Pockets** -----The erosive action of flowing water in streams that removes and carries away material from the bed and banks in a particular area.

**Scrub-shrub Wetland** -----Wetlands dominated by woody vegetation less than 20' tall.

**SCS** -----Soil Conservation Service. Now named NRCS.

**Scupper** -----A small opening, usually vertical, in a deck, curb, or barrier through which water can flow.

**Sea Wall** -----A structure separating land and water areas, primarily designed to prevent flooding and erosion caused by wave action.

**Seasonal High Water Table** -----Shallow water table associated with periods of recent high levels of precipitation and/or low levels of evapo-transportation.

**Section 319 Grant** -----A grant under section 319 of the Clean Water Act, which pays up to 60% of the cost of a project to prevent or control nonpoint source pollution.

**Section 401** -----The section of the PA Clean Streams Law that prohibits pollution of waters of the Commonwealth.

**Section 402** -----The section of the PA Clean Streams Law that prohibits activity that have the potential to pollute waters of this Commonwealth without proper measures to prevent that pollution.

**Section 404** ----The section of the federal Clean Water Act delineating restrictions on the dredging and filling of wetlands as well as impacts to waterways.

**Section 601** ----The section of the PA Clean Streams Law that prohibits unlawful conduct.

**Sediment** ---- Soils or other erodible materials transported by stormwater as a product of erosion.

**Sediment Barrier** ----A permeable wall or fence constructed for the purpose of filtering sediment out of runoff from a disturbed area.

**Sediment Basin** ----An impoundment being used to remove sediment from runoff.

**Sediment Delivery Ratio** ----The fraction of the soil eroded from upland sources that reaches a receiving water or storage basin.

**Sediment Deposition** ----The accumulation of soil particles in an area of reduced water velocity.

**Sediment Filter Log**---- A tube-shaped sediment barrier constructed from straw, flax, rice, coconut fiber, mulch, etc. wrapped with a UV-degradable polypropylene netting, burlap, jute, or coir.

**Sediment Load** ----The amount of soil particles being transported by moving water.

**Sediment Pollution** ----Discharging sediment to surface waters.

**Sediment Pool** ----Sediment storage zone.

**Sediment Storage Zone** ----That part of an impoundment designed to contain the sediment separated from runoff passing through the impoundment.

**Sediment Trap** ----A small impoundment constructed for removal of sediment from runoff.

**Sediment Yield** ----The total amount of sediment that passes any section of a stream during a given time period.

**Sedimentation** ----Deposition of sediment.

**Sedimentation Basin** ----See sediment basin.

**Seedbank** ----The accumulation of viable plant seeds occurring in soil and available for germination under favorable environmental conditions.

**Seedbed** ----Soil prepared by natural or artificial means to promote the germination of seed and the growth of seedlings.

**Seedling** ----A young plant grown from seed.

**Seepage** ----1. Groundwater emerging at the surface. 2. Water flowing through an embankment used to impound water.

**Seep** ----A natural discharge of water from the ground, not usually strong enough to sustain flow.

**Sensitive Species** ----Those plant or animal species susceptible or vulnerable to activity impacts or habitat alterations.

**Sensitivity** ----The ratio of a soil's undisturbed strength to its disturbed strength.

**Separate Sewer System** ----A sewer system that carries sanitary wastes in a system of pipes separate from those carrying storm water runoff.

**Setback** ----1. The positioning of a levee or structure in relationship to a stream bank. 2. A distance from the edge of a water body within which intensive development is restricted. Setbacks are established by local regulation for the purpose of maintaining open space next to streams, lakes, and other water bodies. The area within setbacks is frequently used for flood control, recreation, preservation of drinking water supply, and wildlife habitat enhancement.

**Settlement** ----Movement of an embankment or structure during the application of loads.

**Settling Velocity** ----The rate of downward movement of particles through water.

**Sewer Line** ----A utility line, usually buried, for the conveyance of discharge water, such as storm water runoff or waste water.

**Shallow Concentrated Flow** ----In determining travel time ( $T_C$ ) for runoff calculations, it is the flow regime between sheet flow and channel flow.

**Sharp-crested Weir** ----A device for measuring water, having a notch cut in a relatively thin plate and having a sharp edge on the upstream side of the crest.

**Shear** ----Force parallel to a surface, as opposed to at some angle to the surface. An example of shear is the tractive force that moves particles from a stream bank as water flows along the surface.

**Shear Strength** ----A measure of the ability of a material to resist slope failure, such as slumping, flowing, etc. Materials with low shear strength are more susceptible to landslides and embankment failures.

**Shear Stress** -----In channel design, it is a measurement of the ability of a channel lining to resist being moved due to the forces of water and gravity acting upon it.

**Sheathing** -----A wall constructed to maintain trench wall stability.

**Sheet Erosion** -----The removal of soil particles by surface runoff moving in a fairly uniform layer, as opposed to moving in a concentrated fashion.

**Sheet Flow** -----In determining travel time ( $T_C$ ) for runoff calculations, it is the flow regime before shallow concentrated flow.

**Sheet Piling** -----Piling with a slender flat cross-section, to be driven into the ground or seabed and meshed or interlocked with similar sheets to form a bulkhead. It may be constructed from aluminum, fiberglass, steel, vinyl, wood or other suitable material.

**Shoal** -----A shallow place in a body of water.

**Shore** -----The narrow strip of land in immediate contact with an ocean, lake, or other large body of water, including the zone between high and low water lines. A shore of unconsolidated material is usually called a beach.

**Shoreline** -----1. The edge of water in a lake or other body of water at normal pool elevation. 2. The edge of water along a waterway at the ordinary low water level.

**Short Circuit** -----In sediment basins and traps, it is the undesirable condition of a short flow path through the impoundment from the point of entry to the principal spillway such that not enough time for settlement of sediment is provided.

**Shrink-swell** -----The shrinking of soil when dry and the swelling when wet. Such shrinking and swelling can cause damage to roadways, dams, building foundations, and other structures. It can also damage plant roots.

**Significant Archaeological Site** -----An area of land that contains extensive evidence of previous prehistoric or historic human habitation or stratified deposits of animal or plant remains or manmade artifacts or human burials.

**Significant Change in Slope** -----Any change in the bed slope of a channel such that a different liner or different channel dimensions would be required.

**Silt** -----1. A noncohesive soil whose individual particles are not visible to the unaided human eye — 0.05mm - 0.002 mm. Silt will crumble when rolled into a ball. 2. A soil textural class indicating more than 80% silt.

**Siltation** -----The deposition of silt-sized particles upon the bottom of a water body.

**Silt Fence** -----Filter Fabric Fence.

**Silt Loam** -----A soil texture classification containing large amounts of silt and small amounts of sand and clay.

**Silvicultural Activities** -----All forest management activities, including timber harvesting.

**Single and Complete Project** -----Any activity that is not dependent upon another activity to be viable.

**Sinkhole** -----A depression in the earth's surface caused by dissolving of underlying limestone, salt, or gypsum. Drainage is provided through underground channels that may be enlarged by the collapse of a cavern roof.

**Sinuosity** -----Stream length divided by valley length.

**Skid Trail** -----A temporary pathway over forest soil to drag felled trees or logs to a landing.

**Skimmer** -----A type of basin or trap dewatering device that draws from the top 4 to 6 inches of the water stored in the facility. Theoretically, this should be the cleanest water in the impoundment area.

**Slickenside** -----A surface in fractured bedrock or stiff clay along that differential movement has caused smoothing and/or striations parallel to the direction of the movement.

**Slide** -----The mass movement of earth down a slope.

**Slip Surface** -----A planar or curved surface over which soil or rock has moved.

**Slope** -----Deviation of a surface from horizontal measured in ratio, percent, or degrees, such as ft/ft with the first number typically being the horizontal distance [run] and the second the vertical [rise]. percent, or degrees.

**Slope Breaker** -----Waterbar. **Slope Length** -----In Sediment Barrier Design, it is the distance from the sediment barrier to the top of slope or upslope diversion.

**Slope Pipe** -----A pipe used to convey water downslope to a discharge point.



**Slope Protection** -----A layer or facing of sound, durable rock or similar material (natural or manmade), insoluble in water, selectively placed by hand or machine and sized to resist transport by flowing water.

**Slope Stability** -----The resistance of any inclined surface to failure due to sliding, collapsing, or sloughing.

**Slotted Inlets** -----A section of pipe cut along the longitudinal axis with transverse bars spaced to form slots.

**Sloughing** -----Movement of a mass of soil down a bank.

**Slow Percolation** -----Permeability rate of  $\leq 0.2$  inches/hour.

**Sluice** -----An artificial channel for conducting water with a valve or gate to regulate the flow.

**Slump** -----A type of landslide in which the material rotates along a slip surface. In this type of movement, the top — head — of the slide usually moves down, while the bottom, — toe — moves up and outward.

**Small MS4** -----Municipal separate storm sewer system that is not regulated under Phase I of the NPDES program.

**Social or Economic Justification (SEJ)** -----For earth disturbance activities where discharges to surface waters classified as HQ cannot be avoided and ABACT cannot demonstrably protect existing water quality, the applicant must demonstrate that the degrading discharge is necessary to accommodate important economic or social development in the areas in which the waters are located. This must be done according to the procedure identified in Chapter 10 of the Water Quality Antidegradation Implementation Guidance, Document #391-0300-002 as a separate permit application.

**Sod** -----Plugs, squares, or strips of turf with the adhering soil.

**Soil** -----1. The earth materials which have been so modified and acted upon by physical, chemical, and biological agents that it will support rooted plants. 2. Earthen materials — down to bedrock — affected by an earthmoving project.

**Soil Aggregation** -----The cementing or binding together of several soil particles into a secondary unit, aggregate, or granule for purposes of minimizing erosion potential.

**Soil Amendments** -----Lime, fertilizer, or organic matter added to topsoil to enhance vegetative growth.

**Soil Cement** -----A designed mixture of soil and Portland cement compacted at a proper water content to form a veneer or structure that can prevent streambank erosion.

**Soil Classification** -----The systematic arrangement of soils into groups or categories on the basis of their characteristics.

**Soil Conservation** -----The use of land, within the limits of economic practicality, according to its capabilities and its needs to keep it permanently productive.

**Soil Creep** -----The slow mass movement of soil materials down slopes primarily under the influence of gravity, but facilitated by saturation with water and/or freezing and thawing.

**Soil Erodibility** -----An indicator of a soil's susceptibility to raindrop impact, runoff, and other erosive processes. See K-factor.

**Soil Horizon** -----One of the layers of the soil profile (i.e. A - uppermost layer containing organic material, B - layer where material leached from layer A accumulates, C - parent material from which overlying layers were formed) that has developed characteristics distinct from those of the layers above and below.

**Soil Liquefaction** -----Loss of strength of a soil resulting from the combined effects of vibrations and hydraulic forces, thereby causing the material to flow.

**Soil Loss Tolerance (T)**-----The maximum amount of soil loss, in tons/acre/year, that a given soil type can tolerate and still permit a high level of crop production to be sustained economically and indefinitely. T values for various soil types may be obtained from the Pennsylvania Soil and Water Conservation Technical Guide, USDA NRCS, 1991, as amended and updated.

**Soil Map** -----A map showing soil boundaries, such as those in the Soil Survey.

**Soil Moisture** -----Water in the soil either held by capillary attraction or in the process of movement toward the water table.

**Soil Permeability** -----The ability of soil to allow water or air to move through it. It is usually expressed in inches/hour or inches/day.

**Soil Profile** -----Vertical section of soil showing the nature and sequence of the various layers through all its horizons.

**Soil Series** -----A group of soils that have profiles that are almost alike, except for differences in texture of the surface layer or of the underlying material. All the soils of a series have horizons that are similar in composition, thickness, and arrangement.

**Soil Structure** -----1. The relation of particles or groups of particles of soil that impart to the whole soil a characteristic manner of breaking, such as crumb, block, platy, or columnar. 2. The physical properties of different soils. Sand has little structure because sand particles do not tend to stick together, whereas clay has a firm structure because clay particles tend to pack tightly together to form a solid material.

**Soil Survey** -----A publication by the NRCS on a countywide basis containing soil maps, soil descriptions, and tables of soil characteristics, including limitations.

**Soil Texture** -----A classification of soils based on the size distribution of mineral grains comprising the soil; the relative proportions of silt, sand, clay, and gravel in a soil.

**Soil Use Limitations** -----Common construction, erosion control, and stabilization problems associated with soil types that have been identified by the soil survey. See Appendix E.

**Soldier Pile** -----An upright pile used to hold lagging.

**Solum** -----The upper part of a soil profile, such as the A and B horizons.

**Solute** -----A substance dissolved in a solution.

**SOP** -----Standard Operating Procedure.

**Source Control** -----Action to prevent pollution where it originates.

**Special Conditions to Permit** -----Conditions attached to a permit by the reviewing agency that must be adhered to by the permittee.

**Special Protection Watershed** -----A watershed designated as High Quality (HQ) or Exceptional Value (EV) by Chapter 93.

**Species** -----A group of individuals having a common origin and a continuous breeding system; a single kind of animal or plant.

**Species Diversity** -----The number of different species occurring in some location or under some condition.

**Specific Gravity** -----The ratio of the density of a substance to the density of an equal volume of distilled water at 4° C (39° F).

**Specific Yield** -----1. The ratio of water volume that will drain freely, under gravity, from a sample to the total volume. Specific yield is always less than porosity. 2. The amount of water released from or taken into storage per unit volume of a porous medium per unit change in head.

**Specifications** -----Detailed statements prescribing standards, materials, dimensions, and workmanship for works of improvement.

**Spillway** -----A system of pipes, channels or both designed to convey water from an impoundment in a controlled fashion.

- **Auxiliary Spillway** -----An emergency spillway
- **Ogee Spillway** -----An overflow weir which in cross-section forms an “S” or ogee curve from top to bottom.
- **Primary Spillway** -----The principal spillway
- **Service Spillway** -----A principal spillway used to regulate reservoir releases additional to or instead of the outlet.

**Spiking** -----A method of cultivation in which a soil tine or pointed blade penetrates the turf and soil.

**Splash Erosion** -----The spattering of small soil particles caused by the impact of raindrops on wet soils.

**Splash Zone** -----Portion of a stream bank between the normal flow level and the high-water stage.

**Spoil** -----Excavated or dredged material.

**Sprig** -----The section of plant stem material, such as a rhizome, shoot, or stolon, used in vegetative planting referred to a sprigging.

**Spring** ----- A place where water flows due to the intersection of an aquifer with the surface of the earth.

**Stabilization** -----The proper placing, grading, constructing, reinforcing, lining, and covering of soil, rock or earth to ensure its resistance to erosion, sliding or other movement.

**Stable Channel Flow** -----Channel flow such that the bed slope is less than  $0.7 S_c$  or greater than  $1.3 S_c$ .

**Stable Stream Grade** -----The slope of a natural channel at which neither aggradation nor degradation occurs.

**Stability Analysis** -----An evaluation of the ability of a slope, structure, or system to resist change or failure.

**Stage** -----The elevation of a water surface above its minimum plane or datum of reference.

**Stage Discharge Curve** -----A graph showing the relationship between water depth and outflow from an impoundment.

**Stage Storage Curve** -----A graph showing the relationship between water depth and storage volume provided by a sediment basin or trap.

**Staging** -----Sequencing of BMP installation in relation to other construction.

**Stair Step Grading** -----Construction of a series of short horizontal benches on a cut slope to reduce runoff velocity and retard formation of gullies See Figure 11.1.

**Standard Conditions of Permit** -----Conditions that are an integral part of all such permits issued by a regulatory agency.

**Standard Construction Detail** -----Typical details provided by the Department for use on plan drawings to provide information to contractors necessary to install BMPs according to Departmental standards.

**Standard Silt Fence** ----- An 18" High Silt fence. Also called a Standard Filter Fabric Fence. See Standard Construction Detail # 4-7.

**Standard Proctor Density** -----The optimum unit weight of a soil determined in accordance with ASTM designation D-698 or AASHTO T-99.

**Standard E&S Worksheet** -----A form provided by the Department on which supporting calculations can be submitted. See Appendix B.

**Standing Wave** -----A stationary wave caused by an obstruction in a watercourse. The wave cannot move, or propagate, because the water is flowing at its critical velocity.

**Station** -----On linear projects such as highways, pipelines, etc., it is a measurement of distance from a starting point. Station numbers are typically given in 100s. For example, Station 3 + 25 marks a point 325 feet from the starting point.

**Steady Flow** ----- Flow in which the flow quantity does not vary with time at any location along the channel.

**Stilling Basin** -----A form of outlet protection consisting of an excavated pool downstream of a discharge pipe used to decrease tailwater depth and produce an energy-dissipating hydraulic jump. See Standard Construction Detail 9-4.

**Stilling Well** -----A form of outlet protection using a vertical conduit through which discharge water is thrust upward to the discharge point reducing the energy of the discharge. See Figure 9.8.

**Stocked Trout Stream** -----A stream classified as approved trout waters by the PFBC.

**Stockpile** -----A pile or mound of raw material or product in storage or awaiting shipment.

**Stolon** -----An aboveground stem capable of growing horizontally and producing a new plant.

**Stony** -----In soils, it refers to a soil containing stones in sufficient numbers so as to interfere with or prevent tillage.

**Storage** -----The retention of water or delay in runoff either by planned operation, as in a reservoir, or be temporarily filling the overflow areas, as in the progression of a flood crest through a natural stream channel.

**Storage Capacity** -----The volume of an impoundment available for storage of water and sediment. It is measured from the bottom of the impoundment to the top of the settling zone.

**Storm Drain** -----An opening leading to an underground pipe or open ditch for carrying surface runoff, separate from the sanitary sewer or wastewater system.

**Storm Frequency** -----The time interval between major storm events of predetermined intensity and volumes of runoff, such as 2-year, 5-year, 10-year, etc.

**Storm Sewer (or Storm Drain)** -----A utility line, typically underground, through which storm water runoff is directed to a detention pond, where required, or a receiving water.

**Storm Sewer Inlet** -----A point of entry, usually a drop entry, for storm water runoff into a storm sewer system.

**Storm Surge** -----An increase in water level above the normal water level on an open coast or shore due to wind stress and atmospheric pressure on the water surface.

**Stormwater** ----- Runoff from precipitation, snowmelt, surface runoff, and drainage.

**Stormwater Associated with Construction Activity** -----The discharge into surface waters, municipal separate storm sewers, or non-municipal separate storm sewers from and conveyance which is used for collecting and conveying stormwater and which is related to construction activities. Construction activities include clearing, grading, and excavation activities.

**Stormwater Management** -----Functions associated with planning, designing, constructing, maintaining, financing, and regulating the facilities, both constructed and natural, that collect, store, control, and/or convey stormwater.

**Stormwater Management Facility** -----A system designed to handle storm water runoff and, where required, delay the peak discharge long enough to minimize the potential for downstream flooding.

**Stormwater Storage** -----Temporary storage of excess runoff on, below, or above the surface of the earth for the purpose of attenuating excess runoff.

**Straw Bale Barrier** -----A sediment barrier constructed from staked straw bales. See Standard Construction Detail # 4-13.

**Stream Channel** -----Any watercourse having defined bed and banks, either natural or artificial, with perennial or intermittent flow.

**Stream Crossing** -----Any pipeline, aerial cable, or similar structure that is placed in, along, under, across, or over surface waters.

**Stream Dimensions (Critical)** -----Width, mean depth, width/depth ratio, maximum depth flood prone area width, and entrenchment ratio.

**Stream Enclosure** -----Any bridge, culvert, or other structure in excess of 100 feet in length upstream to downstream which encloses any regulated water of the Commonwealth.

**Stream Enhancement** -----The process of implementing certain stream rehabilitation practices in order to improve water quality and/or ecological function; typically conducted on the stream bank or in the flood prone area but may also include the placement of instream habitat structures. However they should only be attempted on a stream reach that is not experiencing severe aggradation or erosion.

**Stream Entrenchment Ratio** -----Channel width at two times the bankfull depth divided by channel width at bankfull depth.

**Stream Flow** -----The discharge in a natural surface stream course.

**Stream-Forming Flow** -----The rate of flow within a stream channel — equivalent to bankfull flow — responsible for active erosion and deposition of the channel, creating pools, riffles, and meanders; usually having a return period of 1.5 to 2 years.

**Stream Gaging** -----A method of determining the velocity in an open channel.

**Stream Load** -----All the material transported by a stream either as visible sediment or in solution.

**Stream Order** -----A method of categorizing streams. Small streams are first-order; second-order streams are fed by 1<sup>st</sup> order streams; third-order streams are fed by 1<sup>st</sup> and 2<sup>nd</sup> order streams, etc.

**Stream Pattern** -----A stream's sinuosity, meander wavelength, belt width, meander width ratio, and radius of curvature.

**Stream Profile** -----The mean water surface slope, pool/pool spacing, pool slope, and riffle slope

**Stream Relocation Streamflow** -----The movement of water through a stream channel.

**Stream Restoration** -----The process of converting an unstable, altered, or degraded stream corridor, including adjacent riparian zone and flood-prone areas to its natural or referenced, stable conditions considering recent and future watershed conditions. This process also includes restoring the geomorphic dimension, pattern, and profile as well as biological and chemical integrity, including transport of water and sediment produced by the stream's watershed in order to achieve dynamic equilibrium.

**Stream Stabilization** -----The in-place stabilization of an eroding streambank and/or stream bed. Stabilization techniques that include "soft" methods or natural materials, such as root wads, rock vanes, vegetated crib walls, may be considered part of a restoration design. However, stream

stabilization techniques that consist primarily of “hard” engineering, such as concrete lined channels, riprap, or gabions are not typically considered restorations or enhancements.

**Streambank** -----The normal flow boundaries — not the flood boundaries — of a stream channel. Right and left banks are named facing downstream.

**Streambank Erosion** -----Removal of soil particles from a bank slope primarily caused by the moving water, but also by climatic conditions, ice, debris, chemical reactions, and changes in land and stream use.

**Streambank Failure** -----Collapse or slippage of a large mass of bank material into a stream channel.

**Streambank Stabilization** -----The lining of stream banks with riprap, matting, etc. to control erosion. See Chapter 15.

**Streambed Erosion** -----The movement of material, causing lowering or widening of a stream at a given point or along a given reach.

**Strip Cropping** -----Growing crops in a systematic arrangement of strips or bands aligned parallel to contours that serve as barriers to wind and water erosion.

**Structural BMP** -----Constructed facilities whose purpose is to protect receiving surface waters from pollution.

**Sub Drain** -----A backfilled trench containing a perforated pipe for the purpose of intercepting groundwater or seepage.

**Subbase** -----Coarse aggregate stone placed under a paved roadway or parking lot.

**Subcritical Flow** -----The state of flow when the depth of flow is greater than critical depth and velocity is less than the critical velocity, or when the Froude Number is less than 1. A wave from a disturbance can move upstream under subcritical flow conditions.

**Subgrade** -----The portion of a roadbed that has been prepared as specified, upon which a subbase, base, base course, or pavement is to be constructed.

**Submerged Lands of This Commonwealth** -----Water and permanently or periodically inundated lands owned by the Commonwealth, including lands in the beds of navigable lakes and rivers and beds of streams declared public highways that are owned and held in trust by the Commonwealth.

**Subsidence** -----Sinking, collapsing, or cracking of a portion of the earth’s surface caused by underground voids due to mining or solution of bedrock.

**Subsoil** -----The B horizons of soils with distinct profiles. In soils with weak profile development the subsoil can be defined as the soil below which roots do not normally grow.

**Substrate** -----A substance acted upon by an organism, chemical, or enzyme; sometimes used to mean organic material.

**Substratum** -----The part of a soil below the solum.

**Subsurface Drain** -----A pervious backfilled trench usually containing stone and a perforated pipe for intercepting groundwater or seepage.

**Subsurface Layer** -----In soils, a leached horizon (A<sub>2</sub>) lighter in color and lower in content of organic matter than the overlying surface layer.

**Subwatershed** -----A watershed subdivision of unspecified size that forms a convenient natural unit.

**Sump** -----A pit, cistern, or other small containment structure used to collect or drain surface water.

**Sump Pump** -----A pump used to remove accumulated water from a low point in or near a work area.

**Supercritical Flow** -----The state of flow when the flow depth is less than the critical depth and the velocity is greater than the critical velocity, or when the Froude Number is greater than 1. A wave from a disturbance will always be swept downstream under supercritical flow conditions.

**Super Filter Fabric Fence** -----Silt fence attached to a chain link fence. See Standard Construction Detail # 4-10.

**Super Silt Fence** -----Another name for super filter fabric fence.

**Superfund Site** -----An abandoned waste site identified by the EPA as potentially dangerous to human health and the environment.

**Surcharge** -----1. The flow condition occurring in closed conduits when the hydraulic grade line is above the crown of the pipe. 2. In slope stability analysis, it is a weight placed at or near the top of the slope that increases the forces tending to cause slope failure.

**Surface Mining** -----The process of removing soil and overlying rock to gain access to mineral deposits that are relatively close to the surface.

**Surface Retention** -----The part of a storm that does not contribute to runoff. Retention is composed of depression storage, interception, and evaporation.

**Surface Roughening** -----The practice of providing a rough soil surface with horizontal depressions for the purpose of reducing runoff velocity, increasing infiltration, aiding the establishment of vegetation, and reducing erosion.

**Surface Runoff** -----The portion of rainfall that moves over the ground surface toward a lower elevation and does not infiltrate the soil.

**Surface Waters** -----Perennial and intermittent streams, rivers, lakes, reservoirs, ponds, wetlands, springs, natural seeps and estuaries, excluding water at facilities approved for wastewater treatment such as wastewater treatment impoundments, cooling water ponds and constructed wetlands used as part of a wastewater treatment process.

**Suspended Solids** -----Solids that are not in true solution and can be removed by filtration.

**Swale** -----A watercourse without defined bed and banks.

**Switchback** -----A 180 degree — or nearly so — turn in a trail or road used to climb steep slopes.

**SWMP** -----Storm water management plan.

**Synthetic Mat** -----An erosion control blanket manufactured from synthetic materials.

# T

**T** -----In channel calculations, it is the top width of the channel.

**Tackifier** -----A substance sprayed on straw or hay mulch or exposed soil to increase its resistance to wind and reduce its potential for being washed away by runoff.

**Tail Race** -----An open waterway leading water out of a dam spillway and back to a natural channel.

**Tailwater** -----1. The water into which a spillway or outfall discharges. 2. The depth of water downstream of a culvert measured from the outlet invert.

**T<sub>c</sub>** -----In the Rational Equation it is the symbol for time of concentration.

**TDS** -----Total dissolved solids.

**Technical Review Checklist** -----A checklist provided by the Department to aid plan preparers in doing in-house checks of E&S control plans before submitting them and plan reviewers in doing consistent plan reviews.

**Temporary Bypass Channel** -----A suitably sized and stabilized channel constructed for the purpose of conveying base flow around a work area.

**Temporary Riser** -----That part of a barrel/riser type spillway which extends vertically from the bottom of the impoundment to the top of the Settling Zone. See Standard Construction Detail #7-7.

**Temporary Road Crossing** -----A road installed for a period of time not to exceed one year across a wetland or across or along a stream using a pipe culvert or a series of culverts, a bridge, a causeway or a ford.

**Temporary Slope Pipe** -----A pipe installed on a long or steep slope for the purpose of conveying runoff or a discharge down the slope to the desired discharge point.

**Temporary Stabilization** -----Provision of immediate protection from accelerated erosion pending future disturbance, typically in the form of annual seed mixtures and/or mulch.

**Temporary Stream Crossing** -----A stabilized culverted crossing or bridge installed for the purpose of providing access for construction equipment to an area on the other side of a stream channel.

**Temporary Stub** -----A short pipe connecting a temporary riser to a permanent riser in a sediment basin, which will later be converted to a stormwater detention pond. See Standard Construction Detail # 7-8.

**Temporary Vegetation** -----A vegetative cover — annual or perennial, but typically rapid growing annual grasses, small grains, or legumes — used to provide erosion protection to a disturbed area until active earthmoving resumes or permanent protection is provided.

**10-year Storm** -----1. A storm event of such intensity that it occurs on average once every 10 years; 2. A rainfall event having a ten-percent chance of being equaled or exceeded in any given year.

**Tension Crack** -----An opening parallel to the edge of a cut slope or fill slope. It may be a sign of incipient movement.

**Terrace** -----An earthen embankment or a ridge and channel constructed across a slope to intercept surface runoff water and outlet it to surface or underground outlets.

**Terrace Zone** -----Portion of a stream bank inland from the bank zone.

**Test Boring** -----Soil analysis taken by boring holes into the ground to remove samples.

**Texture** -----Refers to the relative proportions of clay, silt, and sand in soil.

**Thalweg** -----The line extending down a channel that follows the lowest elevation of the bed.

**Thank-You-Ma'am** -----Waterbar.

**Thatch** -----A layer of organic material between the crown of the plant and the true soil surface.

**Thermal Impact** -----A measure of the change in temperature in a body of water due to changes in the tributary watershed.

**Thermal Impact Analysis** -----An evaluation of the anticipated changes that will occur in a receiving surface water due to changes in the tributary watershed.

**Thermal Pollution** -----A temperature rise or decrease in a body of water sufficient to be harmful to aquatic life in the water.

**Threading** -----The process of installing a slightly smaller pipe or arch within a failing drainage structure.

**Threatened Species** -----Any plant or animal species likely to become an “endangered” species with the foreseeable future throughout all of a significant area of its range or natural habitat; as identified by the Secretary of the Interior in accordance with the 1973 Endangered Species Act.

**Tidal Wetlands** -----Wetlands affected by ocean tides, such as saltwater marshes, brackish water marshes, mangrove swamps, intertidal flats.

**Tie-back** -----A variety of techniques used to secure a bulkhead, sea wall, or revetment in place against a bank or slope.

**Tile Drainage** -----Land drainage — usually for agricultural purposes — by means of a series of tile lines laid at specific depth and grade.

**Till** -----Non-sorted, non-stratified sediment left by glacial action.

**Till Plain** -----An extensive flat to undulating area underlain by glacial till.

**Tillage** -----The practice of producing a rough soil surface to maintain surface residue, conserve soil moisture, and reduce wind erosion.

**Tiller** -----A plant that produces a new plant at the base of the parent plant.

**Tiltmeter** -----A device used to detect tilt, or rotation, of a surface point.

**Timber Harvesting Activities** -----Logging operation. See Chapter 14.

**Time of Concentration (T<sub>c</sub>)** -----In the Rational Equation, it is the estimated travel time for a drop of water landing at the most distant point, usually the top of a hill, to the point of interest, usually an outfall or a station on a channel. It is the sum of the times for sheet flow, shallow concentrated flow, and channel flow.

**Tipple** -----A facility for loading coal in preparation for transporting it.

**TMDL** -----Total maximum daily load.

**TOAD** -----Team organizing agency development group, an interagency group conducting workshops and training on wetland identification and delineation, plant identification, and hydric soils.

**Toe** -----1. The break in slope at the bottom of a bank or hillside. 2. The portion of a landslide farthest removed from the head.

**Toe Drain** -----1. Drainage system installed at the bottom of a fill to collect excess soil moisture and convey it to a discharge point. 2. Drainage system constructed in the downstream portion of and earth dam or levee to prevent excessive hydrostatic pressure.

**Toe of Dam** -----The base or bottom of the sloping faces of a constructed dam at the point of intersection with the natural ground surface. An inside toe is on the upstream side, while the outside toe is on the down gradient side.

**Toe of Slope** -----The base or bottom of a slope at the point where the ground surface abruptly changes to a significantly flatter grade.

**Toe Zone** -----Portion of a stream bank between the streambed and the normal flow level.

**Top of Streambank** -----First substantial break in slope between the edge of the bed of the stream and the surrounding terrain. The top of streambank can either be a natural or constructed feature, lying generally parallel to the watercourse, such as a road or railroad grade.

**Top-of-Slope Berm** -----A low berm constructed/maintained at the top of a fill slope for the purpose of directing runoff from the top of the fill to a suitable conveyance structure, such as a channel or pipe, discharging to a sediment basin or trap. See Standard Construction Detail #6-4.

**Topdressing** -----A thin layer of soil applied to a turf.

**Topographic Map** -----A map providing contours at sufficient intervals to adequately depict the surface features of a site.

**Topography** -----A general term that includes the characteristics of the ground surface such as plains, hills, mountains, degree of relief, steepness of slope, and physiographic features.

**Topsoil** -----Surface soil usually containing organic matter.

**Total Dissolved Solids** -----A measure of the amount of material dissolved in water, typically carbonates, bicarbonates, chlorides, sulfates, phosphates, nitrates, etc.

**Total Disturbed Area** -----That portion of a project site where earth disturbance activities are planned to occur. For permitting purposes it is measured to the nearest tenth of an acre.

**Total Maximum Daily Load (TMDL)** -----The maximum allowable loading of a pollutant that a designated water body can assimilate and still meet numeric and narrative water quality standards. TMDLs were established by the 1972 Clean Water Act. Section 303(d) of the US Water Quality Act requires states to identify water bodies that do not meet federal water quality standards. In 1996, the states developed — with EPA approval — a list of water bodies that failed to meet section 303(d) standards. These are the focus of TMDLs.

**Total Project Area** -----The entire project site, including areas that are or will be subject to earth disturbance activity as well as those that will not. For permitting purposes, it is measured to the nearest tenth of an acre.

**Total Solids (TS)** -----Total dissolved solids plus total suspended solids.

**Total Storage Volume** -----The available storage in a basin, pond, or trap at the elevation where the required freeboard is provided.

**Total Suspended Solids (TSS)** -----A measure of the solids found in water that can be removed by filtration, typically silt, man-made wastes, etc.

**Toxic** -----Causing acute or chronic damage to biological tissue following physical contact or absorption.

**TR-55** -----An NRCS publication describing a method of estimating runoff from small urban watersheds.

**TR-60** -----An NRCS publication providing specifications for earth dams and reservoirs.

**Tracking Slopes (Trackwalking)** -----A method of surface roughening in which a tracked vehicle, typically a dozer with blade raised, runs up and down a fill slope leaving short horizontal depressions in the surface. See Figure 11.3.

**Tractive Force** -----The drag on a stream bank caused by passing water which tends to pull soil particles along with the streamflow.

**Transient Flow** -----Unsteady flow during a change from a steady-flow state to another steady-flow state.

**Transition Zone** -----1. The area between habitats or ecosystems. 2. The area between uplands and wetlands.

**Transmissivity** -----The rate at which water moves through a unit width of an aquifer or confining bed under a unit hydraulic gradient. It is a function of properties of the liquid, the porous media, and the thickness of the porous media.

**Transpiration** -----The process by which water vapor escapes from living plants, principally from the leaves, and enters the atmosphere.

**Trap Efficiency** -----The ratio of sediment retained within a sediment basin or trap to the sediment inflow, expressed as a percentage.

**Trapezoidal Channel** -----A channel whose cross-section has a relatively flat bottom and sloping sides.

**Trash Rack** -----A structure attached to the top of a principal spillway riser for the purpose of preventing floating debris from entering the pipe and plugging it. See Standard Construction Detail # 7-5.

**Trench** -----A long, narrow excavation for the purpose of burying a pipeline or utility line.

**Trench Breakers** -----Openings in the side of a trench just upslope of a trench plug to allow water in the trench to discharge to a waterbar.



**Trench Plug** -----A flow obstruction, typically constructed from earth-fill sacks, placed in a trench to prevent flow along the pipe either prior to or after backfilling the trench. See Standard Construction Detail #13-4.

**Trespass** -----Any voluntary transgression of law or rule, such as to enter wrongfully upon another's land or to infringe upon another's rights to use water.

**Triaxial Test** -----A common method of testing soil strength.

**Tributary Drainage Area** -----The area above a BMP from which runoff would be expected to flow to the BMP.

**TRM** -----Turf reinforcement matting.

**Trunk Line** -----The main conduit for transporting stormwater. The trunk line is typically deeper than laterals to allow for gravity flow.

**TSF** -----Trout stock fishery, a stream classification used by PFBC.

**TSS** -----Total Suspended Solids.

**Turbidity** -----A measure of the reduced clarity of water caused by suspended particles, such as silt, clay, organic material, etc.

**Turbidity barrier** -----A device to prevent sediment transport in a body of water but retaining sediment particles. The fabric is attached to a flotation device at the top and usually anchored or weighted at the bottom. See Figures 3.14 to 3.17.

**Turbulent flow** -----The type of flow in which individual water particles move in unpredictable paths.

**Turf** -----Surface soil supporting a dense growth of grass and associated root mat.

**Turf Reinforcement Matting** -----A type of erosion control blanket which is intended to increase the maximum allowable shear stress for a vegetative liner.

**Turnout** -----A drainage ditch which drains water away from roads.

**2b Stone** -----The old PennDOT designation for AASHTO #57 stone.

**2-year Storm** -----1. A storm event of such intensity that it occurs, on average, once every 2 years; 2. A rainfall event having a fifty-percent chance of being equaled or exceeded in any given year.

**Type M Inlet** -----A rectangular box-shaped storm water inlet commonly used by PennDOT and other designers.

**Type II Rainfall Distribution** -----A standardized distribution of a 24-hour rainfall event, developed by NRCS, and applicable to most of Pennsylvania per TR-55.

**Typical Detail** -----A construction detail that applies to more than one application of a BMP on a project site.

## U

**Ubiquitous Hydrophytes** -----Plant species that grow either in wetland or on upland areas.

**Unconsolidated** -----Not cemented together or lithified. For example, sand is unconsolidated.

**Underdrain** -----See sub drain.

**Underclay** -----A non-bedded clay occurring below a coal seam; also called a plastic clay or soft clay.

**Undermining** -----The process of scour by hydraulic action that progressively removes earth support from an engineered structure, such as a culvert or sewer.

**Understory** -----Plants growing beneath the canopy of other plants, usually grasses, forbs, and low shrubs.

**Unified Soil Classification System** -----A classification system based upon soil particle size, gradation, plasticity index, and liquid limit.

**Uniform Flow** -----A state of steady flow when the mean velocity and cross-sectional area are essentially constant in all sections of a reach.

**Unit Density** -----A density of one gram per cubic centimeter or one gram per milliliter; the density of water at 4°C or 39.2 °F.

**Unit Hydrograph** -----The hydrograph of surface runoff on a given basin due to an effective rain falling for a unit of time.

**Unit Weight of Water** -----The weight per unit volume of water (62.4 lb/ft<sup>3</sup>).

**Universal Soil Loss Equation** -----An NRCS method of computing the anticipated amount of soil that would be lost per acre of ground during a design storm.

$$A = R \times K \times LS \times C \times P$$

Where: A = soil loss, tons/acre/year

R = rainfall erosion index in 100 ft \* T/ac X in/hr

K = soil erodibility in tons/acre per unit of R

LS = slope length and steepness factor

C = vegetative cover factor

P = erosion control practice factor.

**Unravel** -----To loosen material from the edges of a revetment.

**Unsteady Flow** -----Flow that is changing with respect to time.

**Updrift** -----The direction opposite that of the predominant movement of materials along a shoreline.

**Uplands** -----1. The ground above a floodplain. 2. Land which is neither a wetland nor covered with water.

**Upper Bank** -----Portion of a stream bank above the elevation of the normal flow level.

**Urban Land Use** -----Cities, towns, residential areas, institutional areas, commercial areas, industrial areas, suburban or built-up areas, transportation corridors, railways, airports, ports, or utilities, such as water, sewer, electric, petroleum, communications, etc.

**Urban Runoff** -----Storm water from city streets and gutters that usually carries a great deal of litter and organic and bacterial wastes into the sewer systems and receiving waters.

**USDA** -----U. S. Department of Agriculture.

**USFWS** -----U.S. Fish and Wildlife Service.

**USGS** -----The U. S. Geological Survey, an agency of the U.S. Department of the Interior responsible for providing extensive earth-science studies of the nation's land, water, and mineral resources.

**USGS Quadrangle Map** -----Topographic map of a 7 ½ minute quadrangle published by the USGS.

**Utilidor** -----Utility corridor.

**Utility Line** -----Any pipe or pipeline for transportation of a gaseous, liquid, liquefiable or slurry substance or cable, conduit, line or wire for the transmission of electrical energy, telephone telegraph, radio, or television signals, including cathodic corrosion protection.

## V

**V** -----In channel calculations, it is the symbol for Velocity, typically given in fps.

**V Channel** -----A triangular-shaped channel.

**Vadose Water** -----All underground water above the water table, including soil water, gravitational water, and capillary water.

**Vadose Zone** -----The subsurface zone between the water table and the land surface where some of the spaces between the soil particles are filled with air.

**Varied Flow** ----- Flow with different depths along a watercourse.

**Vegetative Cover** -----All plant species found in an area regardless of size or whether they have forage or other value.

**Vegetative Filter Strip** -----An area having well-established, grassy vegetative cover such that it could receive runoff from a small disturbed area without a pollution event occurring during a design storm.

**Vegetative Retardance** -----The amount of hindrance to flow caused by the type, density, and height of vegetation.

**Vegetative Stabilization** -----1. A vegetative cover that has achieved a Uniform 70% Cover.  
2. Protection of erodible soil in a disturbed area by the establishment of a uniformly thick, perennial vegetation that is erosion-resistant.

**Velocity** -----The rate of motion of water measured in terms of the distance traveled and a unit of time, such as feet per second.

**Velocity Head** -----For water moving at a given velocity, the equivalent head through which it would have to fall by gravity to acquire the same velocity.

- Vernal Pool** -----Wetlands that occur in shallow depressions that are generally underlain by an impervious subsoil layer, such as clay or hard pan.
- Vertical Mowing** -----Use of a mechanical device with vertically rotating blades for thatch and grain control.
- Vetiver Grass** -----Any of several varieties of grass — the most common is *Vetiveria zizanioides*— widely used for erosion control and moisture conservation. When planted as a contour hedge, it slows runoff and filters sediment. The curtain-like root system helps anchor soil and competes minimally with adjacent crop roots.
- Voluntary Compliance** -----Adhering to all pertinent requirements of the PA Clean Streams Law, Departmental rules and regulations, and permit conditions without being forced to by Departmental or court order.
- Vortex** -----A revolving mass of water which forms a whirlpool; a spiral motion of water within a limited area, especially over small open orifice.

# W

- WAAS** -----A differentially corrected reading of latitude and longitude from a GPS system.
- Waiver** -----An exemption for those who desire to do certain types of activities that have very minimal environmental impact from the requirement of obtaining a permit to do such activity.
- Wale** -----Structural element of a bulkhead, fixed horizontally between the vertical piles on the water side and the sheet piles on the land side.
- Warm Season Grasses** -----Species of turf grass that are dormant during the spring and fall, but grow during summer months.
- Wash Rack** -----A facility where vehicle tires can be washed prior to exiting a project site onto a paved roadway. See Standard Construction Detail #3-2.
- Washout** -----The failure of a culvert, bridge, embankment or other structure resulting from the action of flowing water.
- Washout Facility** -----A temporary storage area, above or below ground, for collecting waste water from the cleaning of chutes, mixers, and hoppers of concrete delivery trucks.
- Waste Area** -----An approved site, with BMPs installed and functioning where excess material excavated from the project site may be taken for disposal.
- Wastewater** -----Effluent from a sewage, industrial or water plant, conveyed through a pipe or channel for discharge into a stream or body of water.
- Water Budget (Water Balance)** -----An accounting of the inflows, outflows, and changes in storage of water in a hydrologic unit or system, such as a drainage basin.
- Water Purveyor** -----The owner or operator of a public water supply.
- Water Quality** -----A term used to describe the physical, chemical, thermal, and biological characteristics of water, usually in respect to its suitability for a particular use.
- Water Quality Inlets** -----Pre-cast storm drain inlets, such as oil and grease separators, that remove sediment, oil and grease, and large particulates from paved areas runoff before it reaches storm drainage systems or infiltration BMPs.
- Water Table** -----The surface of a groundwater body at which the water is at atmospheric pressure; the upper surface of the ground water reservoir.
- Waterbar** -----A low berm constructed at an angle across the right-of-way of a pipeline or utility line to direct runoff away from the right-of-way onto a well-vegetated area.
- Watercourse** -----A channel or conveyance of surface water having defined bed and banks, whether natural or artificial, with perennial or intermittent flow.
- Waters of the Commonwealth** -----Rivers, streams, creeks, rivulets, impoundments, ditches, watercourses, storm sewers, lakes, dammed water, wetlands, ponds, springs, and other bodies or channels of conveyance of surface and underground water, or parts thereof, whether natural or artificial.
- Waters of the U.S.** -----All such waters identified by the CWA.
- Watershed** -----An area confined by drainage divides usually having only one streamflow outlet.
- Watertight** -----So tightly made that water cannot enter or escape.

**Wattles** -----Live branch cuttings bound together into long bundles. Also called live fascines.

**Wattling** ----- Use of wattles to stabilize slopes and stream banks.

**WCO** -----Water Conservation Officer of the PA Fish and Boat Commission.

**Weathering** -----The physical disintegration or chemical decomposition of rock due to wind, rain, heat, freezing, thawing, etc.

**Weep Hole** -----Opening left in a revetment or bulkhead to allow groundwater drainage.

**Weighted Runoff Coefficient** -----In the Rational Equation, a runoff coefficient that has been adjusted for varying cover and soil conditions.

**Weighted Sediment Filter Tube** -----A tube-shaped device filled with non-biodegradable filter materials and used to remove sediment from runoff.

**Weir** -----1. A device for determining the quantity of water flowing over it from measurements of the depth of flow over the crest or sill and known dimension of the device. 2. A barrier placed in a channel to divert or regulate flow.

**Weir Flow** -----In riser capacity calculations, it is the flow regime used to calculate the riser capacity at water elevations not far above the crest of the riser.

**Weir Gate** -----Water-control device used to adjust water levels and measure flows simultaneously.

**Weir Notch** -----The opening in a weir for the passage of water.

**Well-graded** -----Materials with particle or rock sizes well distributed over a designated size range.

**Wet Meadow** -----Grassland with waterlogged soil near the surface but without standing water for most of the year.

**Wet Pond** -----A pond designed to store a permanent pool during dry weather.

**Wetland** -----1. An area that meets the criteria — hydric soils, hydrophytic plants, and hydrology — set forth in the 1987 Corps of Engineers Wetlands Delineation Manual 2. An area that is inundated or saturated by surface water or groundwater at a frequency and duration sufficient to support and that under normal circumstances does support, a prevalence of vegetation typically adapted for life in saturated soil conditions, including swamps, marshes, bogs and similar areas.

**Wetland Banking** -----A term used to describe actions required to be taken on the part of developers to mitigate and replace the loss of wetlands. In this case, wetlands are created or restored in order to provide replacement credit for future wetlands impacts.

**Wetland Crossing** -----Trenching through a wetland for a pipeline or utility line.

**Wetland Function** -----The physical, chemical and biological processes or attributes of a wetland without regard to the importance to society.

**Wetland Mitigation** -----Actions taken to avoid, minimize, or deter the need to adversely affect existing wetlands plus the construction or restoration of wetlands to replace those that are affected.

**Wetland Value** -----Wetland processes or attributes that are valuable or beneficial to society.

**WETPAC** -----The Wetland Protection Advisory Committee.

**Wetted Perimeter** -----In a channel, it is the length of the boundary between the water and the channel sides and bottom.

**WGS84** -----World Geodetic System of 1984. A type of horizontal reference datum for latitude and longitude.

**Wild Trout Stream** -----A stream classified as supporting naturally reproducing trout populations by the PFBC.

**Wildlife Cover** ----- Plants or objects used by wild animals for nesting, raising of young, escape from predators, or protection from adverse environmental conditions.

**Wingwall** -----The end portion of a bulkhead, sea wall, or revetment that cuts back in toward the bank at an angle to the main structure to prevent flanking.

**Wood Excelsior Blanket** -----A type of erosion control blanket. Another name for Curlex.

**WQC** -----Water Quality Certification, a permit requirement for federally sponsored projects which are exempt from state Chapter 105 authorization.

**WWF** -----Warm water fish. a stream classification of PFBC.

# Y

**Yellowboy** -----Iron oxide deposits; usually observed as orange-yellow deposits in surface streams affected by drainage from coal mines or related activities.

# Z

**Z** -----The horizontal component of slopes (e.g. the “3” in 3H:1V).

**Zone of Weathering** -----The superficial layer of the earth’s crust above the water table that is subjected to the destructive agents of the atmosphere, and in which soils develop.

## REFERENCES

1. Acker, W. L., Basic Procedures for Soil Sampling and Core Drilling, 1974.
2. Alabama Soil and Water Conservation Committee, Alabama Handbook for Erosion Control and Stormwater Management on Construction Sites and Urban Areas, 2003.
3. Association of Conservation Districts, Erosion and Sedimentation Pollution Control Plan Guide for Small Projects, 1995.
4. Barfield, B.J. and R.C. Warner, Applied Hydrology and Sedimentology for Disturbed Areas, University of Kentucky, DAE, 1983.
5. Canadian Association of Petroleum Producers, Planning Horizontal Directional Drilling for Pipeline Construction, 2004.
6. City of Portland, Erosion Control Manual, 1994.
7. Clark, E. II, J. Havercamp, and W. Chapman. Eroding Soils: The Off-Farm Impact, The Conservation Foundation, Washington, D.C. 1985.
8. Commonwealth of Pennsylvania, DEP, BMR, Engineering Manual for Coal Mining Operations, 563-0300-101, 1999.
9. Commonwealth of Pennsylvania, DEP, BWM, Pennsylvania Stormwater Best Management Practices Manual, 363-0300-002, 2006.
10. Commonwealth of Pennsylvania, DEP, BDWM, Recommended Hydrologic Procedures for Computing Urban Runoff from Small Watersheds in Pennsylvania, 1982.
11. Commonwealth of Pennsylvania, DEP, BLWC, Controlling Erosion and Sedimentation from Timber Harvesting Operations, 1992.
12. Commonwealth of Pennsylvania, DEP, BOGM, Oil and Gas Operators Manual, 2001.
13. Commonwealth of Pennsylvania, DEP, BWM, Technical Paper: "Level Spreaders and Off-Site Discharges of Stormwater to Non-Surface Waters," 2007.
14. Commonwealth of Pennsylvania, DEP, BWSWM, Water Quality Antidegradation Implementation Guidance, 391-0300-002, 2003.
15. Commonwealth of Pennsylvania, Pennsylvania Code, Title 25. Environmental Protection, Chapter 92a - National Pollutant Discharge Elimination System Permitting, Monitoring and Compliance, 2010.
16. Commonwealth of Pennsylvania, Pennsylvania Code, Title 25. Environmental Protection, Chapter 93 - Water Quality Standards, 2001.
17. Commonwealth of Pennsylvania, Pennsylvania Code, Title 25. Environmental Protection, Chapter 102 - Erosion and Sediment Control, 2001.
18. Commonwealth of Pennsylvania, Pennsylvania Code, Title 25. Environmental Protection, Chapter 105 - Dam Safety and Waterway Management, 2005.
19. D'Addario, J., Maccaferri Gabions, 10303 Governor Lane Boulevard, Williamsport, MD.
20. Delaware Sediment and Stormwater Program, Division of Soil and Water Conservation, Delaware Erosion and Sediment Control Handbook, 2003.
21. Dillaha, T.A., III, D.B. Beasley and L.F. Huggins. 1982. "Using the ANSWERS Model to Estimate Yields on Construction Sites", *Journal of Soil and Water Conservation* 37(2): 117-120.
22. Downs, S.C. and Appel, D.H. Progress Report on the Effects of Highway Construction on Suspended-Sediment Discharge in Coal River and Trace Fork, West Virginia 1975-81, USGS Water Resources Investigations Reports 84-4275, 1986.
23. Environmental Protection Agency, Erosion and Sediment Control - Surface Mining in the Eastern U.S. - Design, EPA-625/3-76-006, 1976.
24. Environmental Protection Agency, Storm Water Management for Construction Activities, EPA-832-R-92-005, 1992.
25. Faircloth, J.W. and Son, A Manual for Designing, Installing, and Maintaining Skimmer Sediment Bains, 2001.

26. Filtrexx, Standard Specifications and Design Manual Version 6.0, 2007.
27. GAI Consultants, Inc., Slope Stability Shortcourse for Pennsylvania Department of Environmental Resources, 1982.
28. The Geological Society of America, Application of Geology to Engineering Practice, 1958.
29. Georgia Soil and Water Conservation Commission, Manual for Erosion and Sediment Control in Georgia, 5<sup>th</sup> Edition, 2000.
30. Geosynthetics, Specifier's Guide 2008.
31. Geyer, Alan R. and J. Peter Wilshusen, Engineering Characteristics of the Rocks of Pennsylvania, Commonwealth of PA, DEP, BTGS, EGR1, 1982.
32. Goldman, Steven J., Katharine Jackson, and Tara A. Bursztynsky, P.E., Erosion and Sediment Control Handbook, 1986.
33. Indiana County Conservation District, Controlling Sediment Pollution from Light Duty Gravel/Dirt Roads.
34. Jefferson County, Colorado Planning and Zoning Division, Small Site Erosion and Sediment Control Manual, 2006.
35. Kentucky Division of Water, Kentucky Construction Site BMP Planning and Technical Specifications Manual.
36. Kentucky Division of Water, Kentucky Erosion Prevention and Sediment Control Field Guide.
37. Keown, Malcolm P., Streambank Protection Guidelines for Landowners and Local Governments, USACOE, 1984.
38. Lindeberg, Michael R., Civil Engineering Reference Manual for the PE Exam, 8<sup>th</sup> Ed. 2001.
39. Maine Department of Environmental Protection, Maine Erosion and Sediment Control BMPs, DEPLW0588, 2003.
40. Massachusetts Department of Environmental Protection, Massachusetts Sediment Control Guidelines for Urban and Suburban Areas, 2003.
41. Meyer, L.D. W.H. Winchmeier, and W.H. Daniel. 1971 "Erosion, runoff and revegetation of denuded construction sites". Transactions ASAE 24(6): 1472-1475.
42. National Stone Association, Quarried Stone for Erosion and Sediment Control, 1978.
43. Nevada Division of Water Planning, Dictionary: Technical Water, Water Quality, Environmental, and Water-Related Terms.
44. New York State Department of Environmental Conservation, New York Standards and Specifications for Erosion and Sediment Control, 2005.
45. North Carolina Sedimentation Control Commission, Erosion and Sediment Control Planning and Design Manual, 1988.
46. North Dakota Department of Health, A Guide to Temporary Erosion-Control Measures for Contractors, Designers and Inspectors, 2001.
47. Officine Maccaferri S.p.A., Maccaferri Gabions, 1988.
48. Ohio Department of Transportation, Handbook for Erosion and Sediment Control, 2000.
49. Oregon Department of Transportation, Soil and Rock Classification Manual, 1987.
50. Osterkamp, W., P. Heilman, and L.J. Lane. 1998. Economic Considerations of a Continental Sediment-Monitoring Program. International Journal of Sediment Research 13(4): 12-14.
51. Pennsylvania DEP, Engineering Manual for Coal Mining Operations, 1991.
52. Pennsylvania Department of Transportation, Design Manual, 1995.
53. Pennsylvania Department of Transportation, Guidelines for Design of Erosion, Sediment, and Stormwater Controls, 2004.
54. Pennsylvania Department of Transportation, Specifications, Pub. 408, 1999.

55. Pennsylvania Department of Transportation, Standards for Roadway Construction, Series RC-0 to 100, PDT Pub. #72, 1993 Reprint.
56. The Pennsylvania State University, A Guide to Preserving Trees in Development Projects, 1999.
57. The Pennsylvania State University, An Introduction to Soils of Pennsylvania, 1982.
58. The Pennsylvania State University, Erosion Control and Conservation Plantings on Noncropland, uc150, 1997.
59. The Pennsylvania State University, Understanding Tree Planting in Construction Damaged Soils, 2008.
60. Rosgen, Dave, Applied River Morphology, 1996.
  
61. Schuster, Robert L. and Raymond J. Krizek, ed., Landslides Analysis and Control, National Academy of Sciences, Special Report 176, 1978.
62. State of Alaska Department of Environmental Conservation, User's Manual Best Management Practices for Gravel Pits and The Protection of Surface Water Quality of Alaska, 2006.
63. Terzaghi, Karl, "Mechanism of Landslides", 1950.
64. University of the Virgin Islands Cooperative Extension Service, Sediment and Erosion Control on Construction Sites Field Guide.
65. Urbonas, Ben and Peter Stahre, Stormwater Best Management Practices and Detention for Water Quality, Drainage, and CSO Management, 1993.
66. USDA, Forest Service, Relief Culverts, 1997.
67. USDA, NRCS, Urban Hydrology for Small Watersheds, TR-55, 2005.
68. USDA, NRCS, Web Soil Survey.
69. USDA, SCS, Earth Dams and Reservoirs, TR-60, 1976.
70. USDA, SCS, Engineering Field Handbook - Chapter 16: Streambank and Shoreline Protection, 1996.
71. USDA, SCS, Engineering Field Manual, 1984.
72. USDA, SCS, Engineering Field Manual - Chapter 2: Estimating Runoff and Peak Discharges, 1989.
73. USDA, SCS, Ponds, Planning, Design, Construction, Agricultural Handbook Number 590, 1982.
74. USDA, SCS, West Virginia Erosion and Sediment Control Handbook for Developing Areas, 1993.
75. USDC, NOAA, NWS, Hydrometeorological Design Studies Center, Precipitation Data Server.
76. USDI, Bureau of Reclamation, Design of Small Dams, 024-003-00119-8, 1977.
77. USDOT, FHWA, Design of Roadside Channels with Flexible Linings, HEC No. 15, 1988.
78. USDOT, FHWA, Highway Drainage Design Manual: Hydrology, PB95-219705, 1994.
79. USDOT, FHWA, Highway Hydrology, FHWA-AS-96-067, 1996.
80. USDOT, FHWA, Hydraulic Charts for the Selection of Highway Culverts, HEC No. 5, 1965.
81. USDOT, FHWA, Hydraulic Design of Energy Dissipators for Culverts and Channels, HEC No. 14, 1983.
82. USDOT, FHWA, Hydraulic Design of Improved Inlets for Culverts, HEC No. 13, 1972.
83. USDOT, FHWA, Introduction to Highway Hydraulics, PB97-186761, 1997.
84. USDOT, FHWA, Urban Drainage Design Manual, HEC No. 22, FHWA-SA-96-078, 1996.
85. USDOT, FHWA, Use of Riprap for Bank Protection, HEC No. 11, 1967.
- a) USEPA, et. al., Corps of Engineers Wetlands Delineation Manual, 1987.



86. USEPA, National Pollutant Discharge Elimination System (NPDES), Construction Site Stormwater Runoff Control, 2006.
87. USEPA, Terms of Environment, 2001.
88. Virginia Department of Conservation and Historic Resources, Virginia Erosion and Sediment Control Handbook, 1992.
89. West Virginia Department of Transportation Division of Highways, Erosion and Sediment Control Manual, 2003.
90. Wisconsin Department of Natural Resources - Runoff Management Section, Construction Site Erosion and Sediment Control Standards, 2006.
91. Wu, Tien Hsing, Soil Mechanics, 2<sup>nd</sup> Edition, 1976.