

**YORK TOWNSHIP**  
**CONSTRUCTION AND MATERIALS**  
**SPECIFICATIONS**

January 2005  
Revised April 2009  
Revised August 2015

**C.S. DAVIDSON, INC.**  
Consulting Engineers  
38 North Duke Street  
York, PA 17401  
[www.csdavidson.com](http://www.csdavidson.com)

Phone: (717) 846-4805  
Fax: (717) 846-5811

Price \$

## **ABBREVIATED TABLE OF CONTENTS**

<b><u>SECTION</u></b>	<b><u>DESCRIPTION</u></b>
00100	Terms and Abbreviations
00160	Utility Conflict Statement
02100	Clearing and Grubbing
02150	Boring and Jacking
02210	Site Excavation and Placement of Fill Material
02221	Trenching, Backfilling and Compacting
02230	Roadway Excavation, Fill and Compaction
02270	Soil Erosion and Sediment Pollution Control
02485	Finish Grading, Seeding, and Sodding
02500	Bituminous Paving and Surfacing
02525	Cement Concrete Curb and Sidewalk
02575	Trench Paving and Restoration
02581	Conduit for Underground Utilities
02610	Sanitary Sewer Pipe
02615	Water Mains
02618	Storm Drain Pipe
02630	Inlets, Manholes and Endwalls
02640	Valves and Fire Hydrants
02642	Water Service Connections
02760	Pavement Markings
02820	Fences
02852	Guide Rail
02891	Roadway Signing
02901	Landscaping Planting
03000	Plain and Reinforced Cement Concrete
03050	Cement Concrete for Utility Construction
16500	Street Lighting
Future	Traffic Signals

SECTION 00100

TERMS AND ABBREVIATIONS

I. TERMS

Unless indicated otherwise, the meaning of terms used in these specifications shall be as follows:

Contract is defined as the agreement between a developer and contractor or Municipality and contractor performing the site improvements.

Contractor is defined as company performing the construction of site improvements.

Developer is defined as subdivider or potential buyer, property owner, equitable owner who has executed an agreement with contractor performing site improvements.

Drawings are defined as those land development and subdivision plans or construction documents approved by the municipality.

Engineer is defined as the Township's appointed engineer.

Municipality is defined as York Township and its full-time employees, elected officials and appointed representatives and Authorities.

II. ABBREVIATIONS

The following abbreviations are used in the text of these specifications:

AASHTO	American Association of State Highway Transportation Officials
ACI	American Concrete Institute
ADA	Americans with Disabilities Act
ADT	Average Daily Traffic
ANSI	American National Standards Institute
ASME	American Society of Mechanical Engineers
ASTM	American Society for Testing and Materials
AWWA	American Water Works Association
BCBC	Bituminous Concrete Base Course
DI	Ductile Iron
ESAL	Equivalent Single Axle Load
FS	Federal Specifications
HES	High Early Strength
HMA	Hot Mix Asphalt
HDPE	High Density Polyethylene
IEEE	Institute of Electrical & Electronics Engineers
IES	Illuminating Engineering Society
IESNA	Illuminating Engineering Society of North America
IPCEA	Insulated Power Cable Engineers Association
MUTCD	Manual of Uniform Traffic Control Devices

### ABBREVIATIONS (cont'd)

NEC	National Electric Code
NECS	National Electric Safety Code
NEMA	National Electrical Manufacturers Association
NFPA	National Fire Protection Association
O.D.	Outside Diameter
OSHA	Occupational Safety & Health Administration
PA DEP	Pennsylvania Department of Environmental Protection
PE	Polyethylene
PennDOT	Pennsylvania Department of Transportation
psi	pounds per square inch
PTM	Pennsylvania Test Method
PVC	Polyvinyl Chloride
SALDO	Subdivision and Land Development Ordinance
SDR	Standard Dimension Ratio
SESPC	Soil Erosion and Sediment Pollution Control
UL	Underwriters' Laboratories, Inc.
U.S. DOT	United States Department of Transportation
WWF	Welded Wire Fabric
YCCD	York County Conservation District

### III. YORK TOWNSHIP CONSTRUCTION AND MATERIALS SPECIFICATIONS

The standards and requirements of the York Township Construction and Material Specifications (YTCMS) herein, as amended, shall apply as minimum design and construction standards and requirements for all subdivisions and/or land developments in York Township. In the event any provision York Township SALDO, resolution, or specification of the Township is in conflict with this manual, the standards and requirements of the SALDO shall prevail.

END OF SECTION

SECTION 00160

UTILITY CONFLICT STATEMENT

Any discrepancies between the requirements of these specifications and the requirements of any other authorized agency, such as public utilities, must be resolved prior to commencement of construction activities in order to avoid delays.

END OF SECTION

SECTION 02100

CLEARING AND GRUBBING

PART 1 GENERAL

1.01 DESCRIPTION

A. The work of this section includes, but is not limited to:

1. Clearing
2. Grubbing
3. Stripping and stockpiling topsoil
4. Debris disposal

B. Related Work Specified Elsewhere:

- |  |               |
|--|---------------|
| 1. Site excavation and placement of fill material: | Section 02210 |
| 2. Trenching, backfilling and compacting:          | Section 02221 |
| 3. Roadway excavation, fill, and compaction:       | Section 02230 |
| 4. Soil erosion and sediment pollution control:    | Section 02270 |
| 5. Finish grading, seeding, and sodding:           | Section 02485 |

C. Definitions:

1. Clearing is defined as the removal of trees, brush, down timber, rotten wood, rubbish, any above original ground elevation not designated to be saved. Clearing also includes removal of fences, walls, guard posts, guide rail, signs, and other obstructions interfering with the proposed work.
2. Grubbing is defined as the removal from below the surface of the natural ground of stumps, roots and stubs, brush, organic materials and debris.

D. Applicable Standard Details: NONE

1.02 QUALITY ASSURANCE - Section not utilized

1.03 SUBMITTALS

A. Permits:

1. No burning is permitted in the Municipality.
2. For off-site disposal, submit two copies of the agreement with each property owner releasing the Municipality from responsibility in connection with the disposal of the debris, and permits or approvals from regulatory agencies.

## 1.04 JOB CONDITIONS

- A. The Contractor may clear all obstructions within the construction limits or permanent and construction rights-of-way except those specifically designated to be saved or restored.

## PART 2 PRODUCTS

### 2.01 MATERIALS

#### A. Temporary Fencing:

1. Orange plastic safety fence, 4 foot high minimum.
2. Undamaged picket snow fence, 4' high, formed of wooden slats, tightly woven with wire cable.
3. Soil-set fence posts, studded "T" type, 6' high.

## PART 3 EXECUTION

### 3.01 PREPARATION

- A. Notify the Municipality and regulatory agencies at least 72 hours prior to beginning any clearing work.
- B. Protect benchmarks, utilities, existing trees, shrubs and other landscape features designated for preservation with temporary fencing or barricades satisfactory to the Municipality. No material shall be stored or construction operation carried on within 4-feet of any tree to be saved or within the tree protection fence.
- C. When a private enclosure fence encroaches on the work area, notify the property owner at least 5 days in advance of the clearing/grubbing operations to permit its removal, construct a supplemental fence, or make such other arrangements as may be necessary for security purposes. Upon failure of the property owner to reasonably proceed with the work required to secure his property, carefully remove the fence, in whole or in part, and neatly pile the materials on the property.

### 3.02 UTILITY RELOCATIONS

- A. Inform all companies, individuals and others owning or controlling facilities or structures within the limits of the work which have to be relocated, adjusted or reconstructed in sufficient time for the utility to organize and perform such work in conjunction with or in advance of the Contractor's operations.

B. Comply with the requirements of Pennsylvania Underground Utility Protection Law.

3.03 CLEARING

- A. Confine clearing to within the construction limits.
- B. Clear in a manner that will avoid damage to trees, shrubs, structures, and other installations, which are to be retained.
- C. Where stumps are not required to be grubbed, flush cut with ground elevation.

3.04 GRUBBING

- A. Grub areas within the construction limits to remove roots and other objectionable material to a minimum depth of 24".
- B. Remove all stumps within the cleared areas.

3.05 STRIPPING AND STOCKPILING TOPSOIL

- A. Strip topsoil to whatever depth it may occur from areas to be excavated, filled, or graded and stockpile.
- B. The topsoil shall not be used as backfill.

3.06 DEBRIS DISPOSAL

- A. Trees, logs, branches, brush, stumps, and other debris resulting from clearing and grubbing operations shall be legally disposed of. These items may not be buried on site.
- B. Debris may not be burned - no burning is permitted in the Municipality.

3.07 RESTORATION

- A. Repair all injuries to bark, trunk, limbs, and roots or remaining plants by properly using approved arboricultural practices and materials.
- B. Replace trees, shrubs and plants designated to be saved which are permanently injured or die as a result of construction operations with like species acceptable to the Municipality.
- C. Remove protective fences, enclosures and guards upon the completion of the project.
- D. Restore guard posts, guide rail, signs and other interferences to the condition equal to that existing before construction operations.

END OF SECTION



SECTION 02150  
BORING AND JACKING

PART 1 GENERAL

1.01 DESCRIPTION

A. The work of this section includes, but is not limited to:

1. Approach trench excavation
2. Installation of casing pipe
3. Installation of carrier pipe

B. Related Work Specified Elsewhere:

1. Trenching, backfilling and compacting: Section 02221

C. Definitions: NONE

D. Applicable Standard Details:

YT 02150-1 Casing Installation

1.02 QUALITY ASSURANCE

A. Reference Standards:

1. Comply with applicable federal, state and local ordinances, codes, statutes, rules and regulations, and affected jurisdictional bodies.
2. Pennsylvania Department of Transportation (PennDOT), latest revisions, Publication 408 Specifications.

B. Contractor Qualifications:

1. Construction operations shall be undertaken only by an experienced Contractor with a minimum of five operations of similar magnitude and condition.

1.03 SUBMITTALS

A. Submit history of previous work completed of equivalent nature and scope. Include qualification and experience of key personnel.

- B. Submit description of proposed construction methods, including methods to establish and maintain vertical and horizontal alignment.
- C. Manufacturers' Literature:
  - 1. Submit manufacturers' catalog information for each type of pipe, fittings, couplings, adapters, gaskets, casing spacers, and assembly of joints for approval by the Municipality. Include manufacturers' recommendations for deflection in pipe joints.
- D. Certificates:
  - 1. Submit certifications for each type of pipe, fittings, gaskets, lubricants or other joint materials from the manufacturers attesting that each of these meets or exceeds specifications requirements.

1.04 JOB CONDITIONS

- A. Conduct operations so as not to interfere with, interrupt, damage, destroy, or endanger the integrity of surface or subsurface structures or utilities, and landscape in the immediate or adjacent areas.
- B. When boring or jacking under state highways and railroads, comply with applicable right-of-way occupancy permits.
- C. If boring is obstructed, relocate or jack or tunnel crossing as approved by the Municipality.

PART 2 PRODUCTS

2.01 STEEL CASING PIPE

- A. ASTM A53; 35,000 psi minimum yield strength, new materials only.
- B. Full circumference welded joints.
- C. Diameter and wall thickness as shown on the drawings.
- D. 1 mil thick standard bituminous coating, interior and exterior.

2.02 CASING SPACERS

- A. Non-metallic:
  - 1. High density polyethylene (HDPE) with no metal bolts or attachments. Spacers shall strap onto carrier pipe and slide easily into casing but shall not move during installation.
  - 2. Spacers shall provide constant projections around entire circumference of carrier pipe. Projections must have minimum height to pipe bells, similar to RACI type spacers as manufactured by RACI Spacers of North America, Vernon, British Columbia, or approved equal.

B. Stainless Steel (bolt on):

1. Stainless steel shell with PVC liner, stainless steel hardware, and UHMW polymer runners. Centered Type as manufactured by Cascade Waterworks Manufacturing Company, Yorkville, Illinois, or equal.

C. Timber Skids:

1. Pressure treated, cut to a cross-sectional size to allow placement of the carrier pipe in the casing and to support the barrel of the carrier pipe. Provide with notches to accommodate fastening. Treat notches at time of pipe installation.

2.03 STEEL STRAPPING: ASTM A36

2.04 SAND (Fine aggregate)

- A. Section 703.1, Publication 408 Specifications, Type A.

2.05 GROUT

- A. One part Portland cement (ASTM C150), and 6 parts mortar sand mixed with water to a consistency applicable for pressure grouting.

2.06 FLOWABLE FILL - as specified in Section 02221.

PART 3 EXECUTION

3.01 APPROACH TRENCH

- A. Excavate approach trench using methods as site conditions require.
- B. Ensure pipe entrance face as near perpendicular to alignment as conditions permit.
- C. Establish a vertical entrance face at least 1 foot above top of casing or tunnel lining.
- D. Install adequate excavation supports as specified in Section 02221.

3.02 CASING PIPE INSTALLATION METHODS

A. Boring:

1. Install casing pipe with the determined vertical and horizontal alignment prior to installation of the carrier pipe.
2. Push the pipe into the ground with a boring auger rotating within the pipe to remove the spoil. Do not advance the cutting head ahead of the casing pipe except for that distance necessary to permit the cutting teeth to cut clearance for the pipe. The machine bore and cutting head arrangement shall be removable from within the pipe. Arrange the face of the cutting head to provide a barrier to the free flow of soft material.
3. Do not overcut excavation by more than 1" greater than the outside diameter of the casing pipe.

4. If voids should develop greater than the outside diameter of the pipe by approximately one inch, grout to fill voids.

B. Jacking:

1. Construct adequate thrust wall normal to the proposed line of thrust.
2. Impart thrust load to the pipe through a suitable thrust ring that is sufficiently rigid to ensure distribution of the thrust load on the pipe.

C. Drilling and Jacking:

1. Use an oil field type rock roller bit or plate bit made up of individual roller cutter units solidly welded to the pipe which is turned and pushed for its entire length by the drilling machine to give the bit the necessary cutting action.
2. Inject high density slurry (oil field drilling mud) to the head as a cutter lubricant. Inject slurry at the rear of the cutter units to prevent jetting action ahead of the pipe.

D. Mining and Jacking:

1. Utilize manual hand-mining excavation from within the casing pipe as it is advanced with jacks, allowing minimum ground standup time ahead of the casing pipe.

### 3.03 CARRIER PIPE INSTALLATION WITHIN CASING PIPE

- A. All provisions regarding cleaning, inspection and handling specified under pipe material sections apply to this work.
- B. Place the carrier as shown on Standard Detail YT 02150-1. Exercise care to prevent damage to pipe joints when carrier pipe is placed in casing.
- C. Support pipeline within casing so that no external loads are transmitted to carrier pipe. Attach casing spacers to barrel of carrier pipe at 6' on centers, minimum two (2) per pipe section.
- D. Close ends of casing by sealing with brick masonry bulkheads, water-plug, or other approved hydraulic cement. The downstream bulkhead shall have a 2" diameter stainless steel weephole.
- E. Completely fill annular space between carrier pipe and casing pipe with limestone screenings. If in a State highway right-of-way, fill annular space with flowable fill.

### 3.04 CARRIER PIPE INSTALLATION WITHOUT CASING PIPE

- A. Bore the opening with a boring auger to the determined vertical and horizontal alignment.
- B. Do not overcut boring excavation by more than 1" greater than the outside diameter of the lateral pipe.

- C. Carefully guide the lateral pipe and joints through the opening, assembling joints prior to inserting into the boring.

END OF SECTION

PUMP GROUT BETWEEN CASING AND EXCAVATION IF GREATER THAN 1"

EXCAVATION

1 MIL. BITUMINOUS COATING, BOTH SIDES  
 ANNULAR SPACE TO BE FILLED WITH LIMESTONE SCREENINGS \*  
 STEEL CASING PIPE  
 PIPE BELL

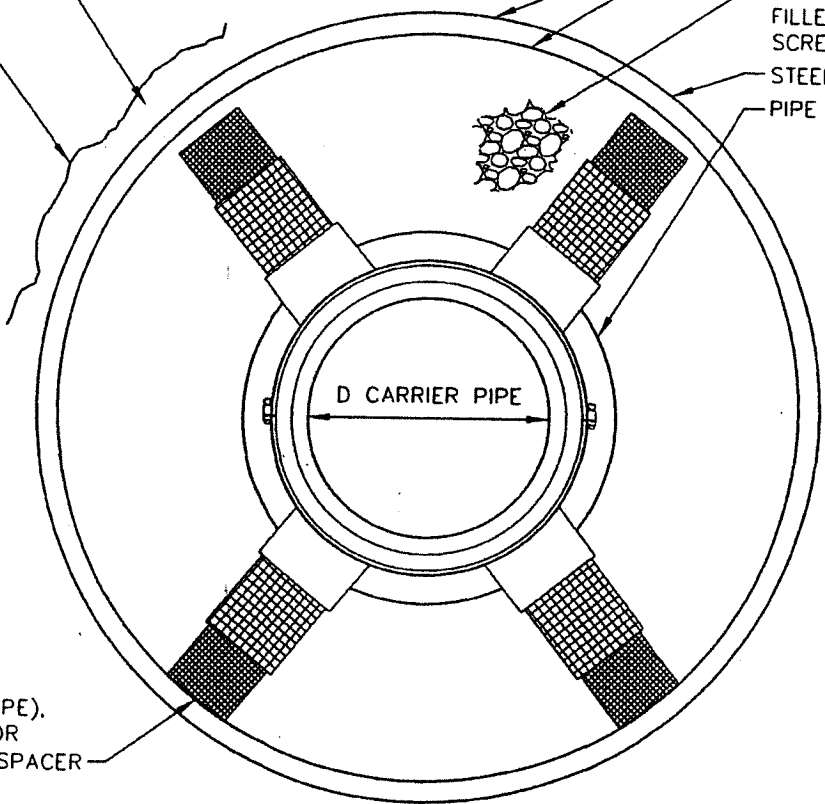

NON-METALLIC (HDPE), STAINLESS STEEL OR OTHER APPROVED SPACER

**NOTE:**  
 DO NOT SUPPORT CARRIER PIPE ON BELLS

\* IF IN STATE HIGHWAY RIGHT-OF-WAY, USE FLOWABLE FILL.

NOTE: NOT TO SCALE

**YORK TOWNSHIP CONSTRUCTION & MATERIALS SPECIFICATIONS**

**YORK TOWNSHIP BOARD OF COMMISSIONERS**  
 190 OAK ROAD  
 DALLASTOWN, PENNSYLVANIA 17313  
 TELEPHONE: 717-741-3861 FAX: 717-741-5009

**CASING INSTALLATION**

DATE:	1/24/2005
DRAWN BY:	ARB
CHK. BY:	SKS
NO.	YT 02150-1

K:\09490003\dwg\YT02150-1.dwg, 1/27/2005 9:51:15 AM

SECTION 02210

SITE EXCAVATION AND PLACEMENT OF FILL MATERIAL

PART 1 GENERAL

1.01 DESCRIPTION

A. The work of this section includes, but is not limited to:

1. Excavation
2. Blasting
3. Placement and compaction of fill material

B. Related work specified elsewhere:

- |   |               |
|---|---------------|
| 1. Clearing and grubbing:                       | Section 02100 |
| 2. Trenching, backfilling and compacting:       | Section 02221 |
| 3. Roadway excavation, fill and compaction:     | Section 02230 |
| 4. Soil erosion and sediment pollution control: | Section 02270 |
| 5. Finish grading, seeding, and sodding:        | Section 02485 |

C. Definitions: NONE

D. Applicable Standard Details: NONE

1.02 QUALITY ASSURANCE

A. Reference Standards:

1. Pennsylvania Department of Transportation (PennDOT), latest revision:

Publication 408, Specifications  
Publication 213, Temporary Traffic Control Guidelines  
Publication RR-459, Occupancy of Highways by Utilities

2. American Society for Testing and Materials (ASTM) latest revision:

D698	Test Method of Laboratory Compaction Characteristics of Soil Using Standard Effort (12,400 ft.-lbf./ft <sup>3</sup> )
D1557	Test Method for Laboratory Compaction Characteristics of Soil Using Modified Effort (56,000 ft.-lbf./ft <sup>3</sup> )
D2922	Test Method for Density of Soil and Soil Aggregate in Place by Nuclear Methods (Shallow Depth)

3. American Association of State Highway and Transportation Officials (AASHTO):

T89	Determining Liquid Limit of Soils
T90	Determining Plastic Limit and Plasticity Index of Soils

B. Testing Agency:

1. Compaction testing shall be performed by a Soils Testing Laboratory engaged and paid for by the Contractor and approved by the Municipality.

C. Compaction Testing:

1. Determine compaction by the testing procedure contained in ASTM D698 or ASTM D1557

1.03 SUBMITTALS

A. Certificates:

1. Submit certified compaction testing results from the Soils Testing Laboratory.

B. One copy of approved Soil Erosion Control Plan, including approval letter from York County Conservation District.

C. One copy of Certification of Origin of Clean Fill or the General Permit registration (for beneficial use activities of regulated fill).

1.04 JOB CONDITIONS

A. Classification of Excavation:

1. Site excavation work includes excavation and removal of all soil, shale, rock, boulders, fill, and all other materials encountered of whatever nature.

B. Control of Traffic:

1. Employ traffic control measures in accordance with Publication 213, Temporary Traffic Control Guidelines.

C. Protection of Existing Utilities and Structures:

1. Take all precautions and utilize all facilities required to protect existing utilities and structures in compliance with Pennsylvania Underground Utility Protection Law. Request cooperative steps of the Utility and suggestions for procedures to avoid damage to its lines.
2. Allow free access to Utility personnel at all times for purposes of maintenance, repair and inspection.

PART 2 PRODUCTS

2.01 ACCEPTABLE MATERIALS

For purposes of construction control, subject to approval and inspection by the Municipality or other specifically designated personnel, the following materials may be deemed acceptable for use in placement of fills:



- A. Soil. Soil shall include all inorganic material having a maximum size that can be readily placed and compacted in loose 8 inch layers and of which more than 35 percent shall pass the No. 200 sieve. Soil shall have a minimum dry weight density of 98 pounds per cubic foot as determined in accordance with PTM No. 106, Method B and a maximum liquid limit of 65 as determined in accordance with AASHTO Designation T89. The plasticity index, as determined by AASHTO Designation T90 for soils having liquid limits of 41 to 65 inclusive, shall be not less than that determined by the formula: Plasticity Index = Liquid Limit - 30.
- B. Granular Material. Granular material shall include all natural or synthetic mineral aggregates having a maximum size that can be readily placed and compacted in loose 8 inch layers and of which 35 percent or less shall pass the No. 200 sieve.
- C. Shale. Shale shall include all rock-like materials formed by the natural consolidation of mud, clay, silt and fine sand and usually thinly laminated, comparatively soft and easily split, having a maximum size that can be readily placed and compacted in loose 8 inch layers.
- D. Rock. Rock shall include all igneous, metamorphic and sedimentary rock having a maximum size that can be readily placed and compacted in loose 8 inch layers and which generally has sufficient fines to normally fill all the voids in each layer.
- E. Random Materials. Random material shall include any combination of the above classifications and may include old concrete, brick, etc., from demolition having a maximum size that can be readily placed and compacted in loose 8 inch layers, and which have been approved by the Municipality.
- F. Flowable Fill. As defined in Section 02221.

### PART 3 EXECUTION

#### 3.01 MAINTENANCE AND PROTECTION OF TRAFFIC

- A. Coordinate the work to ensure the least inconvenience to traffic and maintain traffic on one or more unobstructed lanes unless closing of the roadway is authorized.
- B. Maintain access to all streets and private drives and for emergency vehicles.
- C. Provide and maintain signs, flashing warning lights, barricades, markers, and other protective devices as required to conform to construction operations and to keep traffic flowing with minimum restrictions.
- D. Comply with State and local codes, permits and regulations.

#### 3.02 SALVAGE TOPSOIL

- A. Within the areas indicated for grading, strip topsoil to the depth of suitable topsoil material and stockpile for subsequent topsoiling operations. See Section 02100.

### 3.03 PLACEMENT OF FILL MATERIAL

- A. After removal of topsoil, areas to receive fill shall be thoroughly rolled, and any soft spots disclosed by rolling shall be excavated and the unsuitable material removed and disposed of in a waste area. The excavated area shall be filled with suitable fill material approved by the Municipality and recompacted. Suitable fill material shall be spread in layers of not more than 8 inches (loose) over the full area of the fill, and compacted to the required density by the use of compaction equipment. All fill material shall be compacted to not less than 95% of its maximum dry weight density at its optimum moisture content, plus or minus 2%, as determined by ASTM D698, under roadways, shoulders, driveways, curbs, sidewalks, gravel and sand parking areas and not less than 90% in yards, fields and sand areas.

When the material is too coarse to satisfactorily use these methods, compaction will be determined by the Municipality based on non-movement of the material under the compaction equipment.

- B. Fill material placed in areas inaccessible to the compaction equipment shall be placed in uniform loose layers not exceeding 4 inches in depth and compacted by means of approved mechanical tampers to the density requirements herein specified.
- C. When a previously constructed fill requires additional material to bring it to required elevation, the top of the fill shall be thoroughly scarified before the required additional material is placed.
- D. Material containing moisture in excess of that percentage which will ensure satisfactory compaction shall not be placed in the fill and fill material shall not be placed on material that has become unstable due to excessive moisture.
- E. Frozen fill material shall not be placed in fills, and fill material shall not be placed on frozen material. If during construction the top of the fill freezes, all frozen material shall be removed before additional material is placed.
- F. In no case shall waste material be disposed of in the flood channel or floodway area of any stream.
- G. Shale and random material containing an excessive quantity of large fragments shall be so placed that the coarser material is in areas where no building foundations or utility trenches are to be located. The large pieces shall then be broken down by the use of approved equipment until all voids are filled. Mixtures of shale and rock shall be placed in accordance with the requirements for placing shale.
- H. Where fill is to be constructed on a slope, the slope shall be benched to the width and depth shown on the drawings or as approved by the Municipality.

### 3.04 EXCAVATION

- A. Perform excavation of borrow material in a manner satisfactory to the Municipality. Strip borrow pits of brush, trees, roots, grass and other vegetation prior to removal of material for use in fill. During the excavation operation, grade the borrow area to ensure free drainage of water from the area. Place and maintain erosion control devices after completion of the excavation, grade the excavated area, including side slopes, to drain and present a uniformly trim appearance merging into the surrounding terrain. After borrowing operations are complete, regrade area, if necessary, to prevent erosion.

### 3.05 BLASTING

- A. Notify Municipality at least 24 hours in advance of any blasting activity within the Municipality.
- B. Blasting is the sole responsibility of the Contractor and no duty is assumed or to be exercised by Municipality relative thereto.
- C. Blasting work shall be supervised by licensed and experienced personnel and performed in conformance with applicable Federal, State and local codes.

### 3.06 CONTROL OF EXCAVATED MATERIAL

- A. Provide temporary barricades to prevent excavated material from encroaching on private property, walks, gutters, and storm drains.
- B. Maintain accessibility to all fire hydrants, valve pit covers, valve boxes, curb boxes, fire and police call boxes, and other utility controls at all times. Keep gutters clear or provide other satisfactory facilities for street drainage. Do not obstruct natural water courses. Where necessary, provide temporary channels to allow the flow of water either along or across the site of the work.
- C. All work shall be reviewed and approved by the York County Conservation District.

### 3.07 DEWATERING

- A. Keep excavations dry and free of water. Dispose of precipitation and subsurface water clear of the work.
- B. Intercept and divert surface drainage away from excavations. Design surface drainage systems so that they do not cause erosion on or off the site, or unwanted flow of water.
- C. Comply with Federal and State requirements for dewatering to any watercourse, prevention of stream degradation, and erosion and sediment control.

### 3.08 TOPSOILING

- A. Topsoiling as specified in Section 02485, Finish Grading, Seeding and Sodding.

3.09 DISPOSAL OF EXCAVATED MATERIAL

- A. Excavated material remaining after completion of placement of fills shall be removed from the construction area, and properly disposed of.

3.10 FOREIGN BORROW MATERIAL

- A. Foreign borrow consists of excavation, placement and compaction in fill areas of approved material obtained from sources outside the project limits.
- B. The Contractor shall make his own arrangements for obtaining all foreign borrow material.

END OF SECTION

## SECTION 02221

### TRENCHING, BACKFILLING AND COMPACTING

#### PART 1 GENERAL

##### 1.01 DESCRIPTION

A. The work of this section includes, but is not limited to:

1. Cutting paved surfaces
2. Blasting
3. Trench excavation, backfill and compaction
4. Support of excavation
5. Pipe bedding requirements
6. Control of excavated material
7. Rough grading
8. Restoration of unpaved surfaces

B. Related work specified elsewhere:

- |   |               |
|---|---------------|
| 1. Clearing and grubbing:                       | Section 02100 |
| 2. Boring and jacking:                          | Section 02150 |
| 3. Soil erosion and sediment pollution control: | Section 02270 |
| 4. Finish grading, seeding and sodding:         | Section 02485 |
| 5. Trench paving and restoration:               | Section 02575 |

C. Definitions: NONE

D. Applicable Standard Details:

- YT 02221-1 Pipe Bedding Details
- YT 02221-2 Stream Crossing Detail
- YT 02221-3 Clay Dike Detail

##### 1.02 QUALITY ASSURANCE

A. Reference Standards:

1. Pennsylvania Department of Transportation (PennDOT), latest revision
    - Publication RR-459, Occupancy of Highways by Utilities
    - Publication 408, Specifications
    - Publication 213, Temporary Traffic Control Guidelines
    - Publication 72M, Standards for Roadway Construction
    - Publication 19, Field Test Manual
- PTM No. 106 - Moisture-Density Relations of Soils (using 5.5 lb. Rammer and 12 inch drop)
  - PTM No. 402 - Determining In-Place Density and Moisture Content of Construction Materials by Use of Nuclear Gauges

2. American Society for Testing and Materials (ASTM):

C33	Specifications for Concrete Aggregates
D698	Test Method of Laboratory Compaction Characteristics of Soil Using Standard Effort
D2922	Test for Density of Soil and Soil Aggregate in Place by Nuclear Methods
D1557	Modified Proctor Compaction Test

B. Testing Agency:

1. Compaction testing shall be performed by a PennDOT qualified Soils Testing Laboratory approved by the Municipality.

C. Compaction Testing:

1. Conduct compaction tests as directed by the Municipality during backfilling operations.
2. Determine compaction in state highways and shoulders by the testing procedure contained in PTM No. 106, Method B or PTM No. 402.
3. Determine compaction in areas other than state highways and shoulders by the testing procedure contained in ASTM D698 or ASTM D2922.

1.03 SUBMITTALS

A. Certificates:

1. Submit certification from aggregate suppliers attesting that the pipe bedding and select material stone backfill materials conform to the specifications herein.

B. Compaction Equipment List:

1. Submit a list of all equipment to be utilized for compacting, including manufacturers' lift thickness limitations.

1.04 JOB CONDITIONS

A. Classification of Excavation:

1. Excavation work includes excavation and removal of all soil, shale, rock, boulders, fill, and all other materials encountered of whatever nature.

B. Compaction of Backfill:

1. The degree of compaction required at each location is indicated in the Backfill and Surface Restoration Requirements Table in Section 02575.

C. Control of Traffic:

1. Employ traffic control measures in accordance with Publication 213, Temporary Traffic Control Guidelines.

D. Protection of Existing Utilities and Structures:

1. Take all precautions and utilize all facilities required to protect existing utilities and structures. Comply with the requirements of the Pennsylvania Underground Utility Protection Law. Request cooperative steps of the Utility and suggestions for procedures to avoid damage to its lines.
2. Advise each person in physical control of powered equipment or explosives used in excavation or demolition work of the type and location of utility lines at the job site, the Utility assistance to expect, and procedures to follow to prevent damage.
3. Immediately report to the Utility and the Municipality any break, leak or other damage to the lines or protective coatings made or discovered during the work and immediately alert the occupants of premises of any emergency created or discovered.
4. Allow free access to Utility personnel at all times for purposes of maintenance, repair and inspection.

## PART 2 PRODUCTS

### 2.01 - PIPE BEDDING MATERIAL

- A. AASHTO No. 57 coarse aggregate, Table C, Section 703.2, Publication 408 Specifications.
- B. AASHTO No. 8 coarse aggregate conforming to Section 703, Publication 408, for piping size 2" diameter or less.

### 2.02 - BACKFILL MATERIAL

#### A. Select Material Backfill:

1. Crushed stone or gravel aggregate conforming to PennDOT 2A, Section 703.3, Publication 408 Specifications. Do not use slag or cinders.

#### B. Flowable Backfill Material:

1. Material conforming to PennDOT Special Provision S94 (S2060130), Type A or B as shown in Table 1.

#### C. Suitable Backfill Material (Highways, driveways, and shoulders):

1. From top of pipe bedding material to subgrade elevation:
  - a. Select Material Backfill
  - b. Flowable Backfill Material - Where directed or approved

#### D. Suitable Backfill Material (Other than highways, driveways, and shoulders):

1. From top of pipe bedding material to 24" over top of pipe - Material excavated from the trench if free of stones larger than 2" in size and free of wet, frozen, or organic materials.
2. From 24" above pipe to subgrade elevation -Material excavated from the trench if free of stones larger than 8" in size and free of wet, frozen, or organic materials.

Table 1 - Flowable Fill

Properties & Criteria	Type A	Type B	Type C	Type D
Mix Design ( /cy)				
§ Cement (lbs)*	100	50	150-200	300-700
§ Fly Ash (lbs)*	2000	300	300	100-400
§ Bottom Ash (lbs)* or Coarse Aggregate or Fine Aggregate	0	2600	2600	**
Flow Cone (seconds) ASTM C939	30-60	—	—	30-60****
Slump (inches) PTM No. 600	—	7-11	7-11	7-11****
Density (pcf) PTM No. 613	95-110***	120-135***	125 min. ***	30-70 or as specified ***
Water Absorption of Aggregate, PTM No. 506	—	—	—	20 (max %)
Compressive Strength (psi) PTM No. 604				
§ 3 days (minimum)	25	25	300	40
§ 28 days (range)	50-125	50-125	800 min.	90-400

\* Quantities may be varied or alternate designs submitted to adapt mix to meet density and strength requirements or to adapt to specific site conditions.

\*\* Requires the use of suitable lightweight aggregate or air entraining admixture. Provide a mix design that achieves the specified strength and density requirements.

\*\*\* Approximate Value. Use of air entraining agent may reduce these values.

\*\*\*\* As appropriate depending on whether lightweight aggregate or air entraining admixture is used to obtain lightweight properties.

## PART 3 EXECUTION

### 3.01 MAINTENANCE AND PROTECTION OF TRAFFIC

- A. Maintain traffic in one or more unobstructed lanes and provide access to all streets and private drives.
- B. Provide and maintain protective devices as required by state and local codes, permits, and regulations.
- C. Notify Municipality at least 72 hours in advance of any operations requiring changes to existing traffic patterns.



### 3.02 CUTTING PAVED SURFACES

- A. Where installation of pipelines, miscellaneous structures, and appurtenances necessitate breaking a paved surface, make cuts in a neat uniform fashion forming straight lines parallel with the centerline of the trench. Cut offsets at right angles to the centerline of the trench.
- B. Protect edges of cut pavement during excavation to prevent raveling or breaking; square edges prior to pavement replacement.
- C. The requirement for neat line cuts, in other than state highways, may be waived if the final paving restoration indicates overlay beyond the trench width.
- D. The use of Asphalt Zipper equipment is acceptable.

### 3.03 BLASTING

- A. See Section 02210.

### 3.04 TRENCH EXCAVATION

#### A. Depth of Excavation:

1. Gravity Pipelines - Excavate mainline trenches to the required depth and grade for the invert of the pipe plus that excavation necessary for placement of pipe bedding material.
2. Pressure Pipelines - See York Township Water & Sewer Authority or appropriate water company requirements.
3. Where unsuitable bearing material is encountered in the trench bottom, continue excavation until the unsuitable material is removed, solid bearing is obtained or can be established, or concrete cradle can be placed. If no concrete cradle is to be installed, refill the trench to required pipeline grade with pipe bedding material.
4. Where the Contractor, by error or intent, excavates beyond the minimum required depth, backfill the trench to the required pipeline grade with pipe bedding material.

#### B. Width of Excavation:

1. Excavate trenches to a width necessary for placement and jointing of the pipe, and for placing and compacting pipe bedding and trench backfill around the pipe, but not less than 16" or more than 24" plus the pipe outside diameter from the bottom of the trench to a point 12" above the crown of the pipe.
2. Shape trench walls completely vertical from trench bottom to at least 2' above the top of the pipe. Trench walls from 2' above the top of the pipe to grade to be benched and sloped, or shaved, to comply with Federal and State laws and codes.

#### C. Length of Open Trench:

1. Do not advance trenching operations more than 100' ahead of completed pipeline, except as specified in the State Highway Occupancy Permit.

3.05 SUPPORT OF EXCAVATION

- A. The adequacy of the design of sheeting, shoring and bracing installations relative to the nature of the material to be encountered and retained is the sole responsibility of the Contractor and no duty is assumed or to be exercised by the Municipality relative thereto.
- B. Support excavations with sheeting, shoring, and bracing or a "trench box" as required to comply with Federal and State laws and codes.
- C. Install adequate excavation supports to prevent ground movement or settlement of adjacent structures, pipelines or utilities. Damage due to settlement because of failure to provide support or through negligence or fault of the Contractor in any other manner, shall be repaired at the Contractor's expense.
- D. Removal of sheeting, shoring and bracing as backfilling proceeds is the Contractor's responsibility.

### 3.06 CONTROL OF EXCAVATED MATERIAL

- A. Keep the ground surface on both sides of the excavation free of excavated material to comply with Federal and State laws and codes.
- B. Provide temporary barricades to prevent excavated material from encroaching on private property, walks, gutters, and storm drains.
- C. Maintain accessibility to all fire hydrants, valve pit covers, valve boxes, curb boxes, fire and police call boxes, and other utility controls at all times. Keep gutters clear or provide other satisfactory facilities for street drainage. Do not obstruct natural water courses. Where necessary, provide temporary channels to allow the flow of water either along or across the site of the work.
- D. In areas where pipelines parallel or cross streams, ensure that no material slides, is washed, or is dumped into the stream course. Remove cofferdams immediately upon completion of pipeline construction.
- E. Work shall be in accordance with approved Soil Erosion and Sediment Pollution Control plan and guidelines of the York County Conservation District.

### 3.07 DEWATERING

- A. Keep excavations dry and free of water. Dispose of precipitation and subsurface water clear of the work.
- B. Maintain pipe trenches dry until pipe has been jointed, inspected, and backfilled, and concrete work has been completed. Prevent trench water from entering pipelines under construction.
- C. Intercept and divert surface drainage away from excavations. Design surface drainage systems so that they do not cause erosion on or off the site, or unwanted flow of water.
- D. Comply with Federal and State requirements for dewatering to any watercourse, prevention of stream degradation, and erosion and sediment control.

### 3.08 PIPE BEDDING REQUIREMENTS

#### A. Type III Bedding:

1. Depth of pipe bedding aggregate as shown on Standard Detail YT 02221-1.
2. Provide Type III bedding when installing reinforced concrete storm drain pipe.

#### B. Type IV Bedding:

1. Depth of pipe bedding aggregate as shown on Standard Detail YT 02221-1.
2. Provide Type IV bedding when installing all other pipes larger than 2" diameter.

#### C. Type V Bedding:

1. Depth of pipe bedding aggregate as shown on Standard Detail YT 02221-1.
2. Provide Type V bedding when installing utility conduit and pipe less than 2" diameter.

#### D. Shape recesses for the joints or bell of the pipe by hand. Assure that the pipe is supported on the lower quadrant (under "haunches") and the pipe bottom for the entire length of the barrel. Fill all voids below the pipe.

#### E. Pipe embedment material shall be placed, worked by hand or compacted until a minimum density of 90% in yards and 95% under roadways and sidewalks is achieved (at optimum moisture content, $\pm 2\%$ , standard proctor).

### 3.09 PIPE LAYING

#### A. Provide required pipe bedding placed in accordance with the Standard Details.

#### B. Lay pipe as specified in the appropriate Section of these Specifications for pipeline construction.

### 3.10 BACKFILLING TRENCHES

#### A. After pipe installation and inspection, backfill trenches to 12" above the crown of the pipe with pipe bedding material (crushed aggregate) except for reinforced concrete pipe. Backfill and compact the remainder of the trench with specified backfill material. Under permanent vegetative surfaces, backfill shall be compacted to 90% of maximum dry weight density ( $\pm 2\%$ ) at optimum moisture content. Under all stone or paved surfaces, including sidewalks and parking lots, compact to 95% of maximum dry weight density ( $\pm 2\%$ ).

#### B. Lift Thickness Limitations:

1. Submit a list of the compaction equipment to be utilized on the project, the recommendations of the equipment manufacturer as to the maximum lift thickness which can be placed, and the method of compaction to be used with this equipment to achieve the required compaction. In no case shall maximum lift thickness placed exceed the maximum limits specified by the manufacturer's recommendations. However, if the equipment manufacturer's lift thickness recommendation is followed and the specified compaction is not obtained, the Contractor shall, at his own expense, remove, replace, and retest as many times as is required to obtain the specified compaction.

2. Lift thickness limitations specified for state highways, shoulders, or embankments shall govern over the compaction equipment manufacturer's recommendations.

C. Jetting:

1. When approved by the Municipality in writing, jetting methods may be used to consolidate backfill. Quality assurance methods to verify adequate compaction will be a condition of the approval by the Municipality.

D. Uncompacted Backfill:

1. Where uncompacted backfill is indicated on the drawings, backfill the trench from one foot above the pipe to the top of the trench with material excavated from the trench, crowned over the trench to a sufficient height to allow for settlement to grade after consolidation, providing for surface water drainage.

E. Unsuitable Backfill Material:

1. Where the Municipality deems backfill material to be unsuitable and rejects all or part thereof due to conditions prevailing at the time of construction, remove the unsuitable material and replace with select material backfill.

3.11 DISPOSAL OF EXCAVATED MATERIAL

- A. Excavated material remaining after completion of backfilling shall be removed from the construction area, and legally disposed of.

3.12 ROUGH GRADING

- A. Rough subgrade areas disturbed by construction to a uniform finish. Form the bases for terraces, banks, and lawns.
- B. Grade areas to be paved to depths required where placing subbase and paving materials.
- C. Rough grade areas to be topsoiled and seeded to 4" below indicated finish contours.

3.13 RESTORATION OF UNPAVED SURFACES

- A. Restore unpaved surfaces disturbed by construction to equal the surface condition prior to construction.
- B. Restore grassed areas in accordance with Section 02485, Finish Grading, Seeding and Sodding.

END OF SECTION

K:\091990003\dwg\102221-1.dwg, 1/27/2005 9:52:00 AM

W MIN. = O.D. + 16"  
W MAX. = O.D. + 24"

AASHTO NO. 57  
BEDDING

TYPE III  
(RCP ONLY)

24"

COMPACTED  
SUITABLE  
BACKFILL

.5 O.D.

4" (6" IN  
ROCK)

O.D.

W

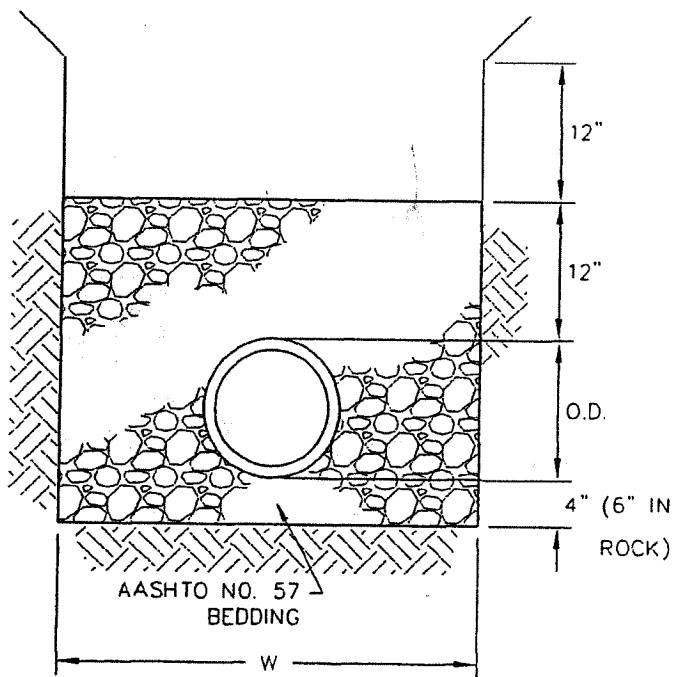

TYPE IV

NOTE: TYPE I AND II NOT PERMITTED.

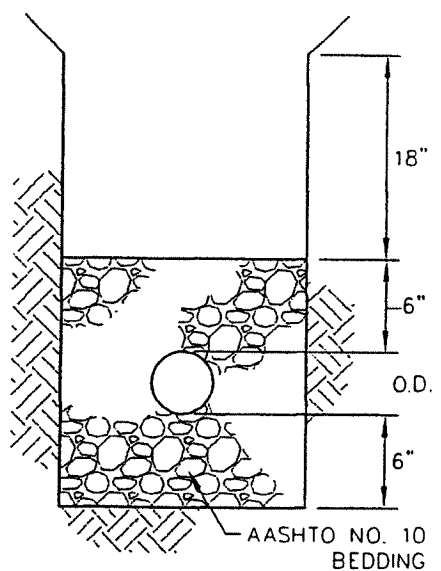

TYPE V  
(2" DIA. AND SMALLER)

NOTE: NOT TO SCALE

**YORK TOWNSHIP CONSTRUCTION & MATERIALS SPECIFICATIONS**

**YORK TOWNSHIP BOARD OF COMMISSIONERS**  
190 OAK ROAD  
DALLASTOWN, PENNSYLVANIA 17313  
TELEPHONE: 717-741-3861 FAX: 717-741-5009

**PIPE BEDDING DETAILS**

DATE:	1/24/2005
DRAWN BY:	ARB
CHK. BY:	SKS
NO.	YT 02221-1

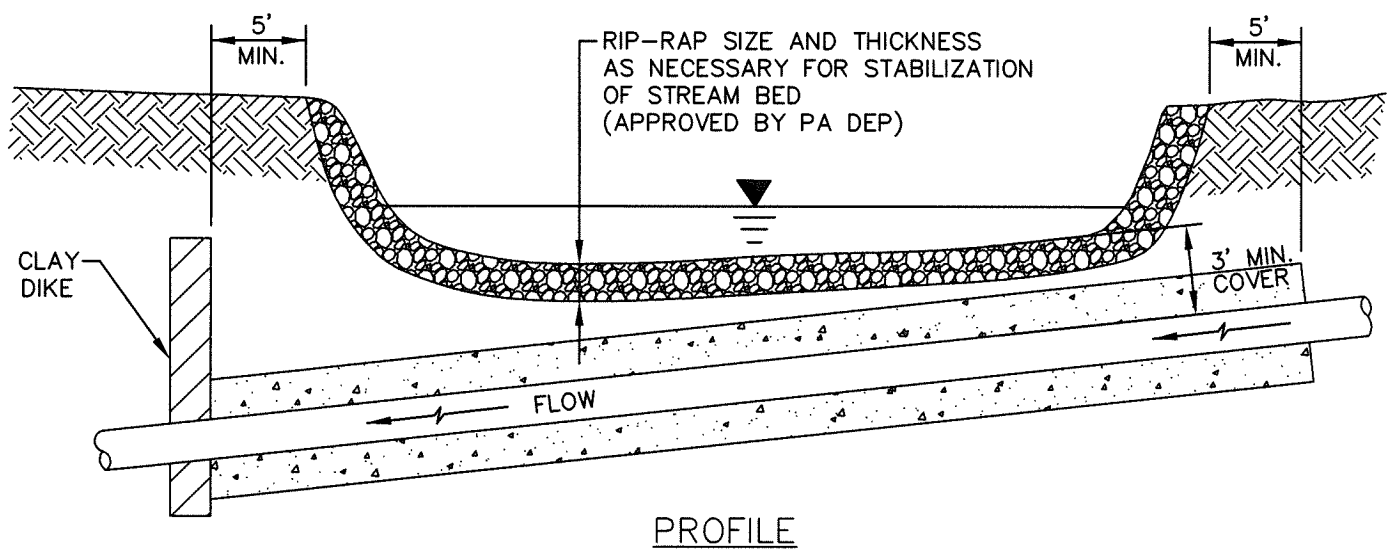
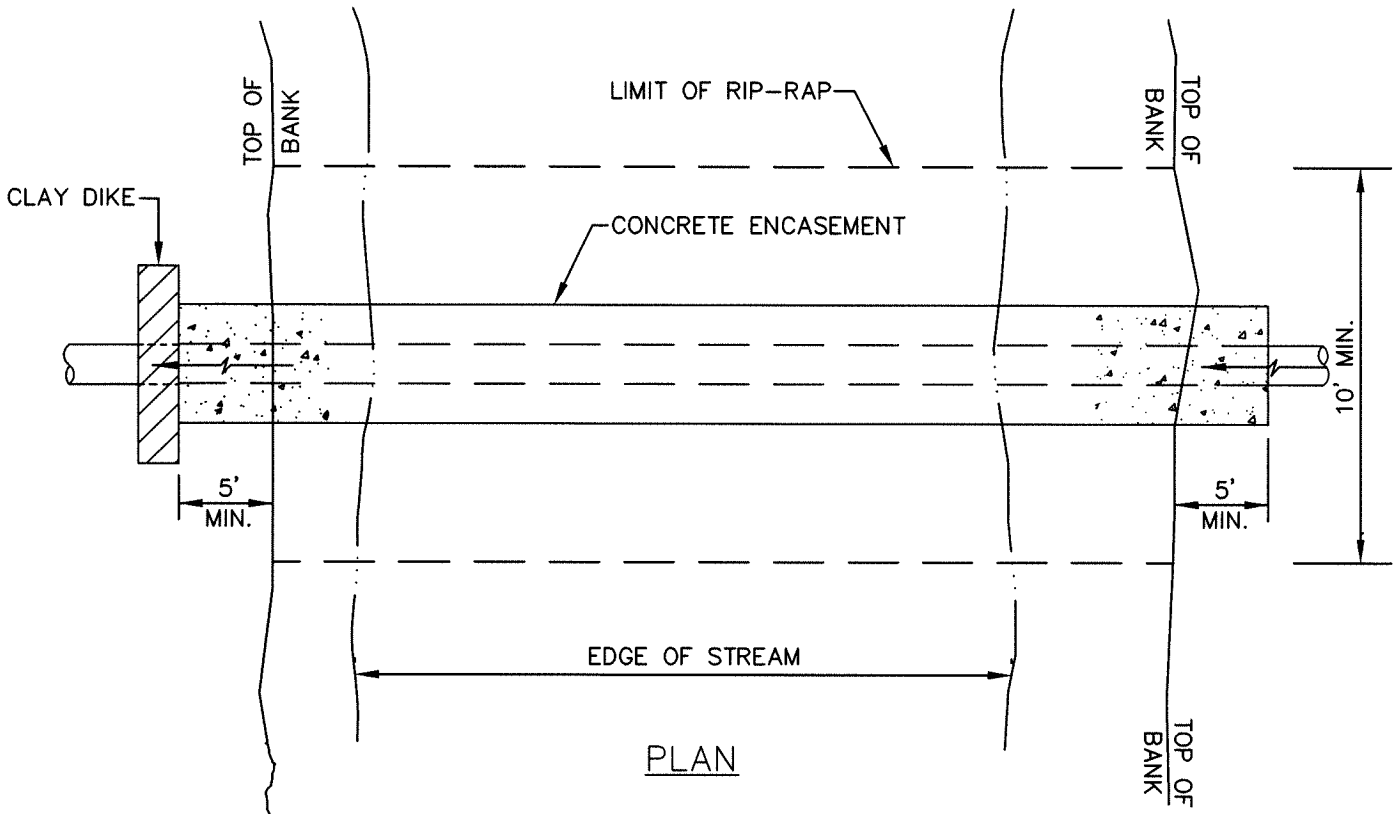

\*SUBJECT TO ALL THE REQUIREMENTS OF PADEP PERMIT\*

NOTE: NOT TO SCALE:

YORK TOWNSHIP CONSTRUCTION & MATERIALS SPECIFICATIONS

**YORK TOWNSHIP BOARD OF COMMISSIONERS**  
 190 OAK ROAD  
 DALLASTOWN, PENNSYLVANIA 17313  
 TELEPHONE: 717-741-3861 FAX: 717-741-5009

**STREAM CROSSING**  
**DETAILS**

DATE: 03/30/09  
 DRAWN BY: MJL  
 CHK. BY:  
 NO. YT-02221-2

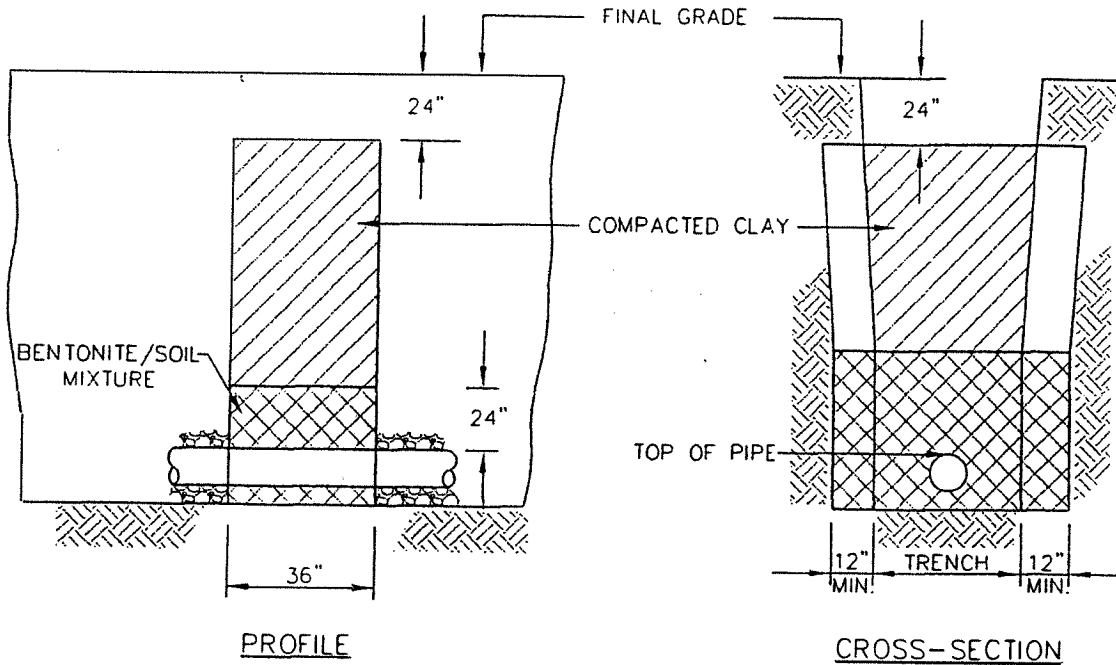

**NOTES:**

1. COMPACTED CLAY DIKES SHALL EXTEND VERTICALLY FROM UNDISTURBED GROUND AT BOTTOM OF TRENCH TO WITHIN 24" OF FINAL GRADE, AND FROM UNDISTURBED GROUND ON TRENCH SIDES FOR WIDTH OF TRENCH AND 12" BEYOND EACH SIDE OF TRENCH.
2. CLAY BACKFILL TO A POINT 24" OVER THE PIPE SHALL CONSIST OF A BENTONITE /SOIL MIXTURE AT A 5:1 MIX.
3. REMAINING BACKFILL SHALL CONSIST OF CLAY CONTAINING NO MORE THAN 15% (BY VOLUME) STONE NOT LARGER THAN TWO (2") INCHES IN DIAMETER. CLAY SHALL BE PLACED IN SIX (6") INCH LIFTS AND COMPACTED BY MECHANICAL TAMPER TO NOT LESS THAN 95% OF MAXIMUM DENSITY AT OPTIMUM MOISTURE CONTENT.

NOTE: NOT TO SCALE

**YORK TOWNSHIP CONSTRUCTION & MATERIALS SPECIFICATIONS**

**YORK TOWNSHIP BOARD OF COMMISSIONERS**  
 190 OAK ROAD  
 DALLASTOWN, PENNSYLVANIA 17313  
 TELEPHONE: 717-741-3861 FAX: 717-741-5009

**CLAY DIKE DETAIL**

DATE:	1/24/2005
DRAWN BY:	ARB
CHK. BY:	SKS
NO.	YT 02221-3

K:\09\090003\dwg\YT02221-3.dwg, 1/27/2005 9:52:58 AM

## SECTION 02230

### ROADWAY EXCAVATION, FILL AND COMPACTION

#### PART 1 GENERAL

##### 1.01 DESCRIPTION

###### A. The work of this Section includes but is not limited to:

1. Excavation
2. Compaction
3. Fill
4. Subgrade Preparation
5. Base Preparation

###### B. Related work specified elsewhere:

- |  |               |
|--|---------------|
| 1. Clearing and grubbing:                          | Section 02100 |
| 2. Site excavation and placement of fill material: | Section 02210 |
| 3. Finish grading, seeding and sodding:            | Section 02485 |
| 4. Bituminous paving and surfacing:                | Section 02500 |
| 5. Soil erosion and sediment pollution control:    | Section 02270 |

###### C. Definitions:

1. Roadway: Area under and within ten feet of the edge of paving.
2. Roadway Subgrade: The prepared earth surfaces on or over which additional roadway materials will be placed or work is to be performed.

###### D. Applicable Standard Details:

- YT 02500-1 Typical Street Cross Section
- YT 02500-2 Street Widening Detail
- YT 02500-3 Pavement Base Drain Detail
- YT 02500-4 Local Street (without curbs) Cross Section
- YT 02500-5 Residential Driveway Profile (curbed street)
- YT 02500-6 Residential Driveway Profile (no curbs)

##### 1.02 QUALITY ASSURANCE

###### A. Reference Standards:

1. American Association of State Highway and Transportation Officials (AASHTO):
  - T99 Moisture-Density Relations of Soils, Using a 5.5-lb. Rammer and a 12-in. Drop
  - T191 Standard Method of Test for Density of Soil In-Place by the Sand Cone Method.



2. American Society for Testing and Materials (ASTM):  
D2922 Test Method for Density of Soil and Soil-Aggregate in Place by Nuclear Methods (Shallow Depth).
3. Pennsylvania Department of Transportation (PennDOT), latest revision:  
Publication 408, Specifications

B. Inspections:

1. Inspection by the Municipality will, at a minimum, be made of the subgrade prior to placement of the base course, and of the base course prior to placement of the binder surface.

1.03 SUBMITTALS

A. Certificates:

1. Submit certification from aggregate suppliers attesting that materials conform to specifications herein. Certification shall be provided with each load of crushed aggregate delivered to the job site.

- B. One copy of the approved SESPC plan, including approval letter.

1.04 JOB CONDITIONS

- A. As specified in Section 02210.

PART 2 PRODUCTS

2.01 ACCEPTABLE FILL MATERIALS

- A. Roadway Fill Areas: As specified previously under Site Excavation and Placement of Fill Material, Section 02210.
- B. Embankment Fill Areas: As specified previously under Site Excavation and Placement of Fill Material, Section 02210.
- C. Excavated Areas: Suitability of material for subgrade purposes shall be determined by non-movement of the material under compaction equipment.

2.02 STONE BASE

- A. Coarse aggregate - hard, tough, durable and uncoated inert particles reasonably free from clay, silt, vegetation and other deleterious substances. Coarse aggregate shall be obtained from an approved source.

## 2.03 GEOTEXTILES

- A. For all areas of wet subgrade - Class 4 Type A or B as defined in PennDOT Pub 408, Section 735, and as approved by the Engineer.
- B. For pavement base drains - Class 1 as defined by PennDOT Pub 408, Section 735, and as approved by the Engineer.

## PART 3 EXECUTION

### 3.01 SUBGRADE

- A. Perform soil erosion control work in accordance with the approved soil erosion plan.
- B. Roadway Excavation: Excavate or otherwise remove and satisfactorily dispose of materials located within the limits indicated on the drawings for roadways.
  - 1. Excavate to roadway subgrade depths required, and cut drainage channels and waterways as detailed on the drawings. Proof roll subgrade to the satisfaction of the Municipality.
  - 2. Remove rock encountered in roadway excavation to a depth six inches below finished subgrade elevation.
  - 3. Excavate unsuitable subgrade material. Refill such areas to required elevation with acceptable materials.
  - 4. Place geotextile layer in wet areas prior to placing final base course.
- C. Roadway Grading: Shape subgrade of roadways, intersections, approaches, entrances and adjoining pedestrian walkways to no more than 0.10 foot above or below the design elevations.
- D. Roadway Fill: Construction requirements for roadway fill shall be as follows:
  - 1. Form the roadway fill with acceptable materials.
  - 2. Compact material to a minimum final density of not less than 95% of the maximum dry weight density at its optimum moisture content plus or minus 2%. Proof roll roadway fill to the satisfaction of the Municipality.
- E. Roadway Embankment: Construction requirements for roadway embankment shall be as follows:
  - 1. Break up shale and other rock-like materials formed by natural consolidation of mud, clay, silt and fine sand into a maximum size that can be readily placed and compacted in loose eight-inch layers.
  - 2. Place rock to form the base of roadway embankments. Place in uniform loose layers not exceeding in depth the approximate average size of the larger rock, but not exceeding 8 inches deep.
  - 3. Smooth and level each layer adding soil or granular material conforming to Section 02210, in sufficient quantity to supplement the smaller rock pieces, filling the voids and pockets.
  - 4. Form the top 18 inches of roadway embankments with soil or granular material conforming to Section 02210.

5. Compact embankment material to a minimum final density of not less than 95% of the maximum dry weight density at its optimum moisture content plus or minus 2%. Proof roll embankments to the satisfaction of the Municipality.
6. During foreign borrow excavation operations, keep the borrow area graded to ensure free water drainage. Following completion of work in the borrow area, grade the area to present a uniformly trim appearance merging into the surrounding terrain and to prevent erosion.

### 3.02 BASE COURSES

#### A. Subbase Course

1. Compact subgrade material to a minimum final density of not less than 95% of the maximum dry weight density at its optimum moisture content plus or minus 2%. Perform finish rolling on roadway subgrade just prior to installation of aggregate subbase or base course.
2. When indicated on the drawings or directed by the Municipality, construct subbase in accordance with PennDOT Publication 408 Specifications, Section 350.

#### B. Crushed Aggregate Base Course (2A Modified Stone)

1. Compaction shall be achieved by means of approved static or vibratory equipment (5 ton GVW minimum). If static roller is used, base course of more than 8 inches shall be constructed in two lifts. If approved vibratory roller is used, base course up to 10 inches compacted thickness may be constructed in one course.
2. On prepared subgrade (or subbase if required), construct stone base of 2A modified coarse aggregate to the compacted depth specified on the standard details.
3. Spreading Coarse Material: The aggregate material shall be spread uniformly by approved mechanical stone spreaders to the full width of the base unless otherwise specified for part-width construction. Spreaders shall be adjusted to spread the loose material to obtain a layer of the required depth after compaction. In areas inaccessible to spreading equipment, the material may be spread directly from trucks provided the distribution is equivalent to that achieved by the spreader. All segregated material shall be removed and replaced with well graded material. The aggregate material shall not be spread for a distance of more than an average day's work ahead of compacting.
4. Compacting Coarse Material: Immediately after surface corrections have been made to the spread material, it shall be compacted. The rolling shall begin at the sides and progress to the center, except on super elevated curves where the rolling shall begin on the low side and progress to the high side. The rolling shall be parallel with the centerline of the roadway, uniformly lapping each preceding track, covering the entire surface with the rear wheels and continuing until the material does not creep or wave ahead of the roller wheels. After each layer of material has been spread and compacted, it shall be checked with approved templates and straightedges, and all irregularities shall be satisfactorily corrected. Red flags shall be placed at the limits of satisfactorily compacted material. The flags shall be moved ahead as additional material is compacted.

5. Maintenance and Traffic: The Contractor shall maintain the completed base course until the placement of the surface course. No traffic shall be allowed on the base course other than necessary local traffic and that developing from the operation of essential construction equipment. Any defects which may develop in the construction of the base course or any damage caused by the operation of local or job traffic is the responsibility of the Contractor and shall be immediately repaired or replaced at no expense to the Municipality.

C. Alternate Base Course: PennDOT 2A Stone. Construct in accordance with Article 3.02.B.

D. Crushed Aggregate Base Course for Street Widening

1. PennDOT 2A - see paragraph 3.02.B.

E. Crushed Aggregate Shoulders

1. PennDOT 2A

F. Pavement Base Drain - See Section 02618.

### 3.03 FIELD QUALITY CONTROL

A. Surface Tolerance.

After the base course has been completed as specified, the surface smoothness shall be checked with approved templates, string lines, or straightedges.

1. Templates: The Contractor shall furnish and use approved templates of required length and cut to the required crown of the finished surface of the base course, for checking the crown and contour thereof. The templates shall be equipped with metal or other approved vertical extensions attached to each end, so that the bottom of the template will be at the elevation of the top of the aggregate. At least 3 such templates shall be furnished, and used at intervals of not more than 25 feet.
2. String Lines: String lines, for controlling the finished elevation of the proposed base course, shall be furnished with ample supports and offset along each side of the base course, and shall be maintained until all irregularities have been satisfactorily corrected.
3. Straightedges: Approved straightedges 10 feet in length shall also be furnished and used for testing longitudinal irregularities in the surface of the base course.

Any surface irregularities that exceed ½ inch shall be remedied by loosening the surface and removing or adding material as required, after which the entire area, including the surrounding surface, shall be rolled until satisfactorily compacted.

B. Tests for Depth of Finished Base Course: During the progress of the work, the depth of the base course will be measured by the Municipality and unsatisfactory work shall be repaired, corrected, or replaced. The Municipality will not be liable for payment for any excess depth of base course. The initial layer of fine material placed as a bed and filler will be measured and considered as part of the base course in determining the compacted depth of the finished base course.

1. The depth will be determined by cutting or digging holes to the full depth of the completed base course. One depth measurement shall be made for each 1500 square yards, or less, of completed base course. Any section in which the depth is  $\frac{1}{2}$  inch or more deficient in specified depth, shall be satisfactorily corrected at no expense to the Municipality.
  2. All test holes shall be backfilled with similar material and satisfactorily compacted by and at the expense of the Contractor. This operation shall be performed under the observation of the Municipality who will check the depth for record purposes.
- C. Field Moisture-Density Tests: Conduct such tests as specified under Site Excavation and Placement of Fill Material: Section 02210.

END OF SECTION

SECTION 02270

SOIL EROSION AND SEDIMENT POLLUTION CONTROL

PART 1 GENERAL

1.01 DESCRIPTION

A. The work of this section includes, but is not limited to:

1. Installation of soil erosion and sediment pollution control (SESPC) measures as per approved plan.
2. Maintenance of SESPC measures.
3. Restoration of area and removal of any interim SESPC measures placed to protect areas from erosion during stabilization period.

B. Related work specified elsewhere:

- |  |               |
|--|---------------|
| 1. Clearing and grubbing:                          | Section 02100 |
| 2. Site excavation and placement of fill material: | Section 02210 |
| 3. Finish grading, seeding, sodding:               | Section 02485 |
| 4. Storm drain pipe:                               | Section 02618 |

C. Applicable Standard Details:

- YT 02270-1 Rock Barrier Detail
- YT 02270-2 Rock Basin Detail
- YT 02270-3 Rock Lining Detail
- YT 02270-4 Soil Erosion Control for Structures
- YT 02270-5 Silt Barrier Fence Detail
- YT 02270-6 Temporary Diversion Swale Detail
- YT 02270-7 Storm Inlet Protection Detail
- YT 02270-8 Straw Bale Barrier Detail
- YT 02270-9 Stabilized Construction Entrance Detail

In the event of a conflict between these details and PA DEP/York County Conservation District details, the current PA DEP and York County Conservation District Standard Details shall govern work.

1.02 QUALITY ASSURANCE

A. Reference Standards:

1. Pennsylvania Department of Transportation (PennDOT), latest revision:  
  
Publication 408, Specifications  
Publication 72M, Roadway Construction Standards

2. Pennsylvania Department of Environmental Protection (PA DEP):

Soil Erosion and Sedimentation Control Manual

3. Asphalt Institute Specifications

1.03 SUBMITTALS

A. A Soil Erosion and Sediment Pollution Control plan for this project must be approved by the York County Conservation District. This plan may not be adjusted by the Contractor without prior approval of the County Conservation District and other regulatory agencies as applicable.

1.04 JOB CONDITIONS: Section Not Utilized.

PART 2 MATERIALS

2.01 STONE FOR RIP-RAP

A. Stone used shall be the type and size of rip-rap shown on the drawings and shall meet the requirement of Publication 408, Section 850.

2.02 MATTING FOR EROSION CONTROL

A. The Contractor shall furnish a certification from the manufacturer that the matting conforms to the requirements prescribed hereinafter.

B. Jute matting for erosion control:

1. As specified in Publication 408, Section 806.2(a).

C. Excelsior matting:

1. As specified in Publication 408, Section 806.2(b).

D. Nylon matting:

1. As specified in Publication 408, Section 806.2(d).

2.03 EROSION CONTROL DEVICES

A. Silt Barrier Fence:

1. Geotextiles, Class 3: As specified in Publication 408, Section 735.1 (a) (b) (c) (d) and Section 865.2 (a).

2. Mesh Support: As specified in Publication 408, Section 865.2(b).

3. Post:
  - a. Wood or steel or acceptable plastic with equivalent section and sufficient length for height of fence required.
  - b. As specified in Publication 408, Section 865.2 (c).
4. Fasteners: As specified in Publication 408, Section 865.2(d).
5. Ground Anchors, Guy Wires: As specified in Publication 408, Section 865.2 (e) (f).

#### 2.04 TEMPORARY COVER

- A. Seed: As specified in Section 02485.
- B. Seed Mixtures: As specified in Section 02485.
- C. Inoculant: As specified in Section 02485.

#### 2.05 SOIL SUPPLEMENT MATERIALS

- A. Fertilizer: As specified in Section 02485.
- B. Agricultural Lime: As specified in Section 02485.

#### 2.06 MULCHING MATERIALS

- A. Straw: As specified in Section 02485.
- B. Wood Cellulose Fiber: As specified in Section 02485.
- C. Mulching Binder:
  1. Emulsified Asphalt: SS-1, CSS-1, CMS-1, MS-2, RS-1, RS-2, CRS-1, or CRS-2. Designations from Asphalt Institute Specifications.
- D. Wood Chips: Wood chips, recovered from clearing and grubbing operation will be acceptable as mulch for seeding and shall be used at a rate of 35 cubic yards per acre.

#### 2.07 STORM DRAIN PIPE

- A. As specified in Section 02618.

#### 2.08 PUMPED SEDIMENT CONTROL DEVICE

- A. Nonwoven geotextile fabric bag that collects silt from pumped water, such as Dirtbag manufactured by ACF Environmental, Inc., Richmond, VA, or approved equal.
- B. Bag must be sized to accommodate flow rates and maintained as recommended by the manufacturer.



2.09 INLET SEDIMENT CONTROL DEVICE

- A. Woven polypropylene fabric bag such as Siltsack, as manufactured by ACF Environmental, Inc., Richmond, VA, or approved equal, sized to fit inlet.

PART 3 EXECUTION

- 3.01 Notify County Conservation District a minimum of 7 days prior to initiating earthmoving.
- 3.02 A copy of the SESPC Plan must be available at the site of earthmoving activity during construction and until the site is stabilized.
- 3.03 SESPC measures shall be implemented by the Contractor before earthmoving activities are started. The plan shall be strictly adhered to, and the Contractor shall maintain all SESPC measures until permanent soil cover has been established.
- 3.04 The following minimum control measures shall be employed by the Contractor:
  - A. Reduce by the greatest extent practicable the area and duration of exposure of readily erodible soils;
  - B. Protect soils by use of temporary vegetation, or by seeding and mulching, or by accelerating the establishment of permanent vegetation and completing disturbed areas of work as rapidly as is consistent with construction schedules;
  - C. Retard the rate of runoff from the construction site and control the disposal thereof;
  - D. Trap sediment from the construction site in silt basins, including pump discharges from dewatering operations;
  - E. Sprinkle or apply dust suppressors to keep dust within tolerable air quality limits on haul roads and at the construction site;
  - F. Utilize temporary measures to control soil erosion on construction operations suspended for more than 20 calendar days;
  - G. Provide protection against discharge of pollutants such as chemicals, fuel, lubricants, sewage, etc. into streams or storm water facilities;
  - H. Keep all construction debris, excavated material, rocks, and refuse incidental to the work out of any stream channel, gutter lines and drainage channels.
- 3.05 Do not permit mud or silt-laden water to leave the construction site, and is responsible for any and all damages to downstream properties as a result of his failure to prevent such damages.
- 3.06 At such time permanent soil cover has been established, remove all temporary SESPC measures.
- 3.07 Temporary control measures must be maintained, including disposal and replacement of damaged or filled devices.

END OF SECTION

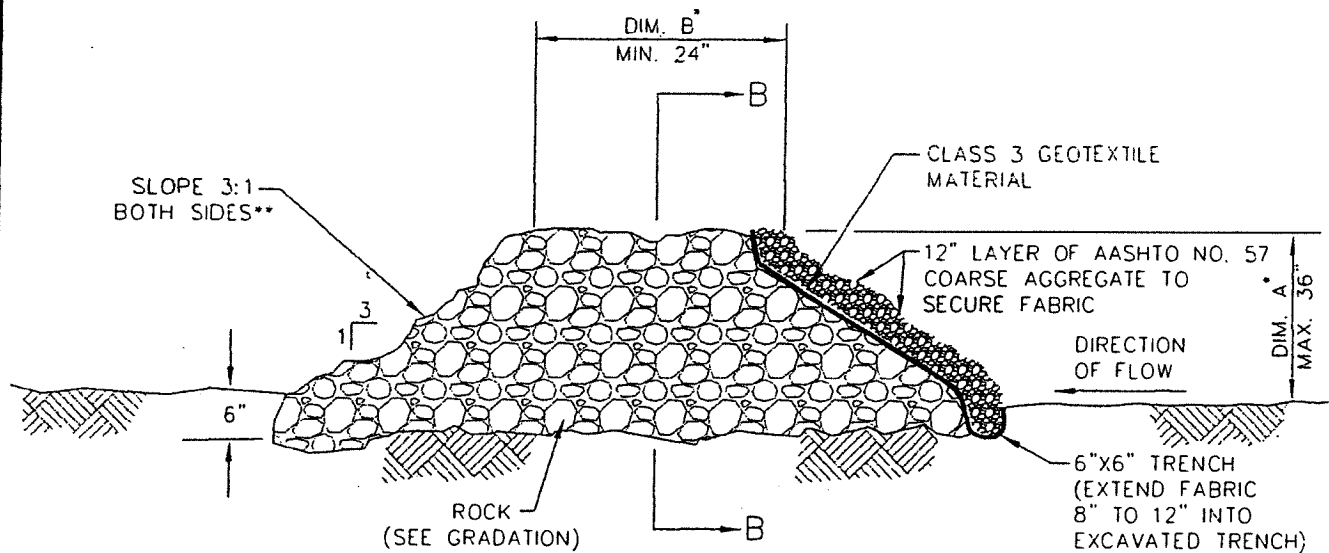

**TYPICAL SECTION**

- \* REFER TO CONTRACT DRAWINGS FOR INDIVIDUAL BARRIER DIMENSIONS AND LOCATIONS.
- \*\* SLOPE SHALL BE 1:1 WHEN USED AS ROCK FILTER OUTLET
- DIM. A = 5/6 HEIGHT OF SILT BARRIER FENCE WHEN USED AS ROCK FILTER OUTLET.
- NOTE: SEDIMENT MUST BE REMOVED WHEN ACCUMULATIONS REACH 1/2 HEIGHT OF ROCK BARRIER.

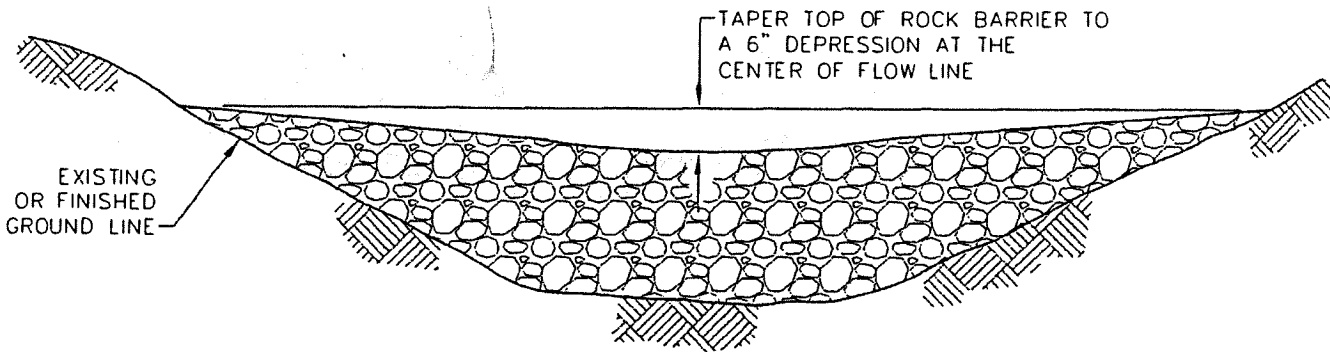

**SECTION B-B**

HEIGHT (DIM. A)	ROCK
3' OR LESS	R-4
2'-3'	R-3
1'-2'	R-2

NOTE: NOT TO SCALE

**YORK TOWNSHIP CONSTRUCTION & MATERIALS SPECIFICATIONS**

**YORK TOWNSHIP BOARD OF COMMISSIONERS**  
 190 OAK ROAD  
 DALLASTOWN, PENNSYLVANIA 17313  
 TELEPHONE: 717-741-3861 FAX: 717-741-5009

**ROCK BARRIER  
 DETAIL**

DATE:	1/24/2005
DRAWN BY:	ARB
CHK. BY:	
NO.	YT 02270-1

K:\091990003\dwg\YT02270-1.dwg, 1/27/2005 9:53:20 AM

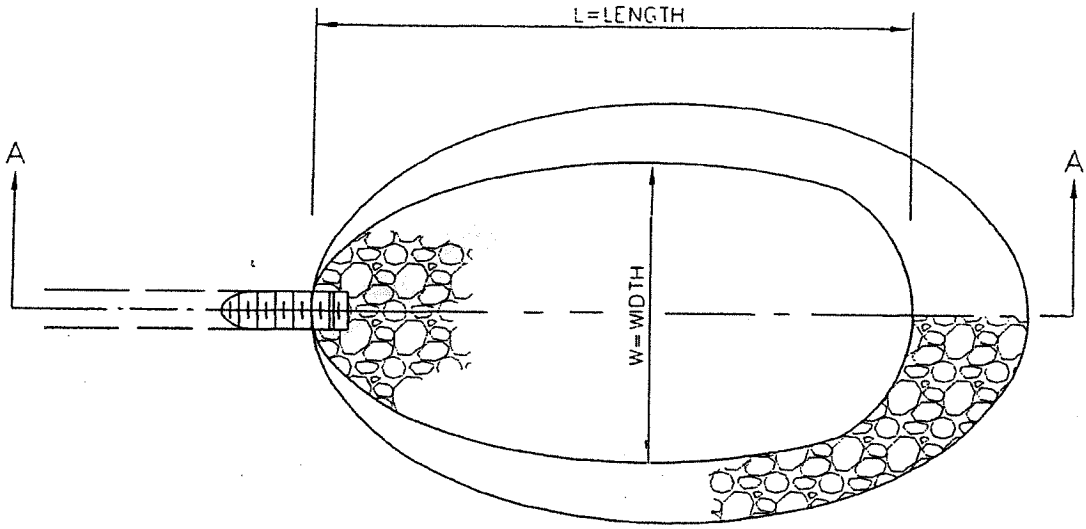

PLAN

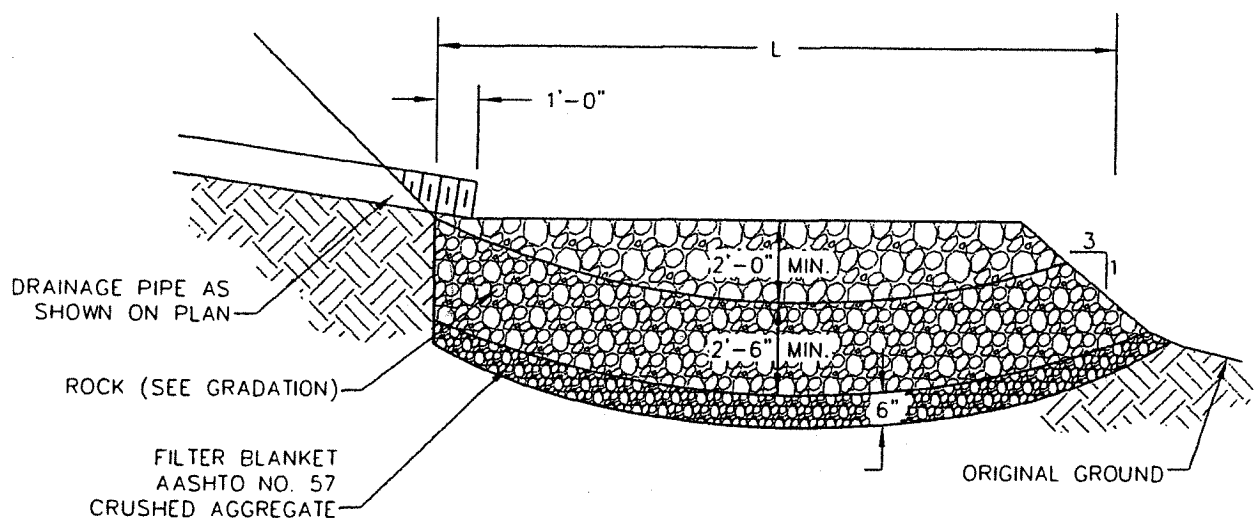

SECTION A-A

ROCK GRADATION

ROCK SIZE	MAX. % OF TOTAL WEIGHT SMALLER THAN GIVEN SIZE
36"	100%
24"	50%
12"	10%

"L" AND "W" AS SHOWN ON DRAWINGS

NOTE: NOT TO SCALE

YORK TOWNSHIP CONSTRUCTION & MATERIALS SPECIFICATIONS

YORK TOWNSHIP BOARD OF COMMISSIONERS  
 190 OAK ROAD  
 DALLASTOWN, PENNSYLVANIA 17313  
 TELEPHONE: 717-741-3861 FAX: 717-741-5009

ROCK BASIN DETAIL

DATE:	1/24/2005
DRAWN BY:	ARB
CHK. BY:	SJS
NO.	YT 02270-2

K:\091990003\dwg\YT02270-2.dwg, 1/27/2005 9:51:01 AM

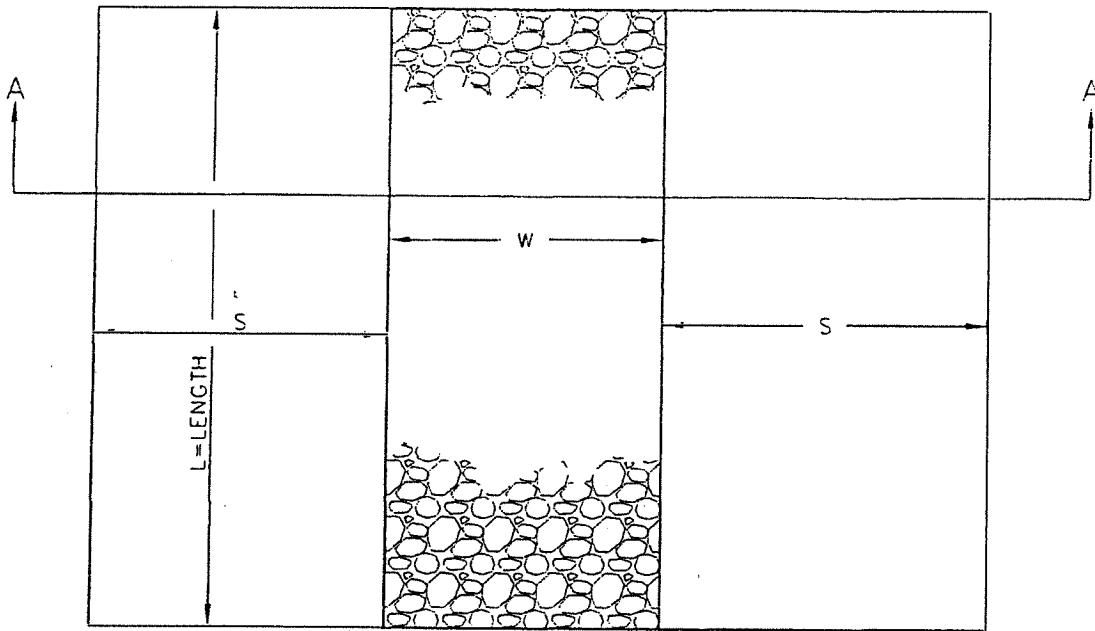

PLAN

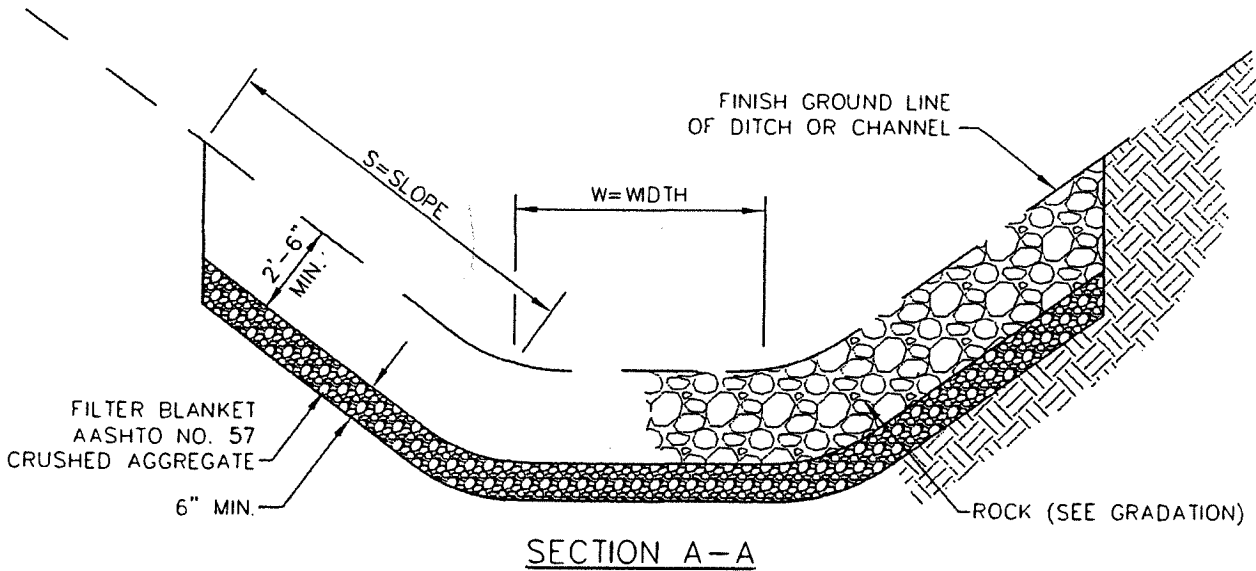

SECTION A-A

ROCK GRADATION

<u>ROCK SIZE</u>	<u>MAX. % OF TOTAL WEIGHT SMALLER THAN GIVEN SIZE</u>
36"	100%
24"	50%
12"	10%

"S", "L" AND "W" AS SHOWN  
ON DRAWINGS

NOTE: NOT TO SCALE

**YORK TOWNSHIP CONSTRUCTION & MATERIALS SPECIFICATIONS**

**YORK TOWNSHIP BOARD OF COMMISSIONERS**  
 190 OAK ROAD  
 DALLASTOWN, PENNSYLVANIA 17313  
 TELEPHONE: 717-741-3861 FAX: 717-741-5009

**ROCK LINING DETAIL**

DATE: 1/24/2005  
 DRAWN BY: ARB  
 CHK. BY: S+S  
 NO. YT 02270-3

K:\091990003\dwg\YT02270-3.dwg, 1/27/2005 9:51:12 AM

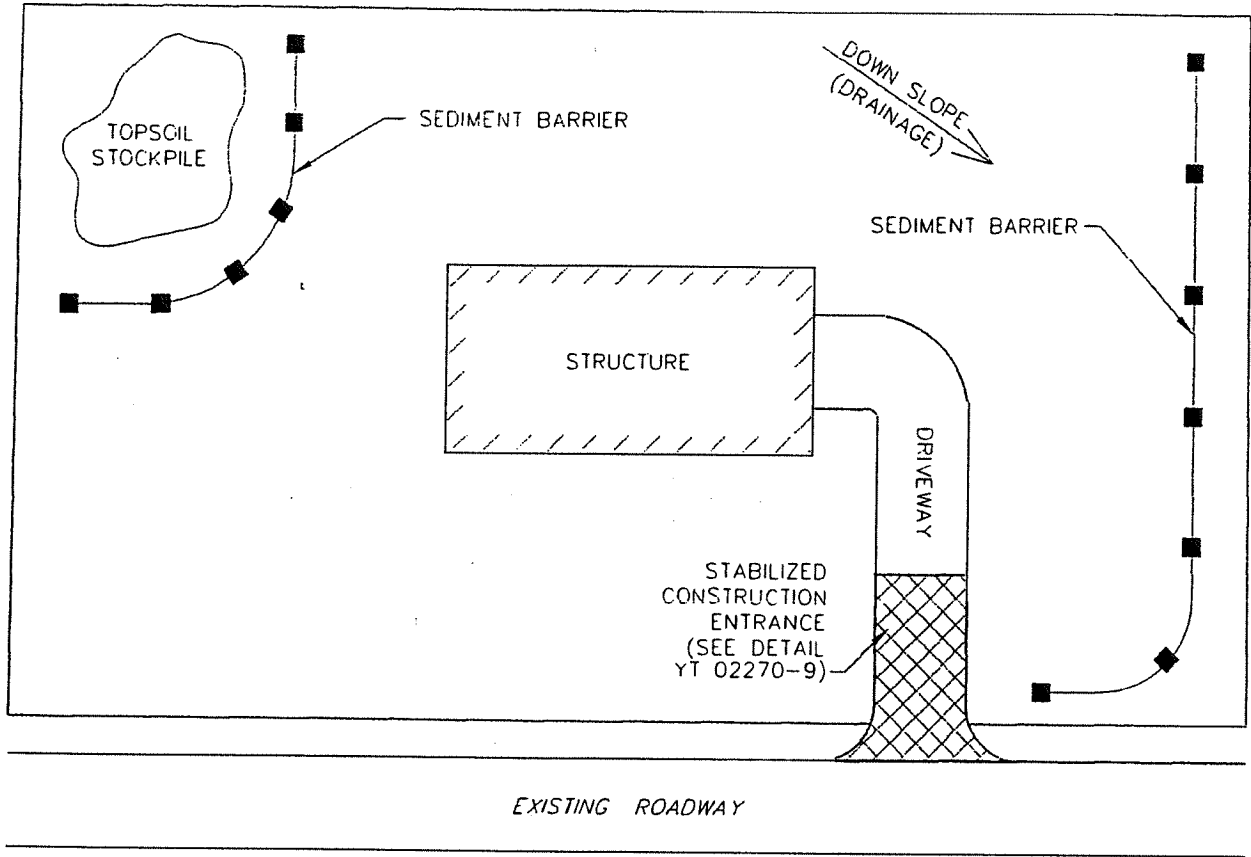

TYPICAL CONSTRUCTION SEQUENCE

1. INSTALL STABILIZED CONSTRUCTION ENTRANCE.
2. INSTALL ACCEPTABLE SEDIMENT BARRIERS ALONG THE DOWNSLOPE EDGE OF THE PROPERTY.
3. STRIP TOPSOIL AND STOCKPILE ON UPSLOPE PORTIONS OF THE AREA.
4. ROUGH GRADE THE AREA.
5. SEED AND MULCH ALL DISTURBED AREAS. TEMPORARY COVER SHALL BE ANNUAL RYE GRASS APPLIED AT A SEEDING RATE OF 10 POUNDS PER 1000 SQUARE YARDS.
6. INSPECT AND MAINTAIN EROSION AND SEDIMENTATION CONTROLS ON A REGULAR BASIS. EROSION AND SEDIMENTATION CONTROLS SHALL NOT BE REMOVED UNTIL THE DISTURBED AREAS ARE STABILIZED.
7. ENSURE ALL VEHICLES LEAVING THE SITE HAVE MUD REMOVED FROM TIRES AND UNDERCARRIAGES.

NOTE: NOT TO SCALE

**YORK TOWNSHIP CONSTRUCTION & MATERIALS SPECIFICATIONS**

**YORK TOWNSHIP BOARD OF COMMISSIONERS**  
 190 OAK ROAD  
 DALLASTOWN, PENNSYLVANIA 17313  
 TELEPHONE: 717-741-3861 FAX: 717-741-5009

**SOIL EROSION CONTROL  
 FOR STRUCTURES**

DATE:	1/24/2005
DRAWN BY:	ARB
CHK. BY:	SJS
NO.	YT 02270-4

K:\091920003\dwg\YT02270-4.dwg, 1/27/2005 9:55:21 AM

STAKES SPACED @ 8'  
MAX. USE 2"x2" WOOD OR  
EQUIVALENT STEEL STAKES.

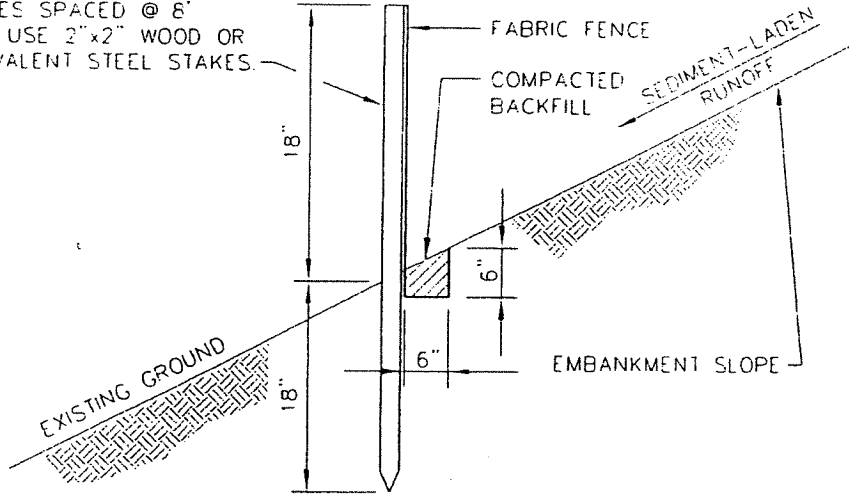

18" SILT FENCE DETAIL

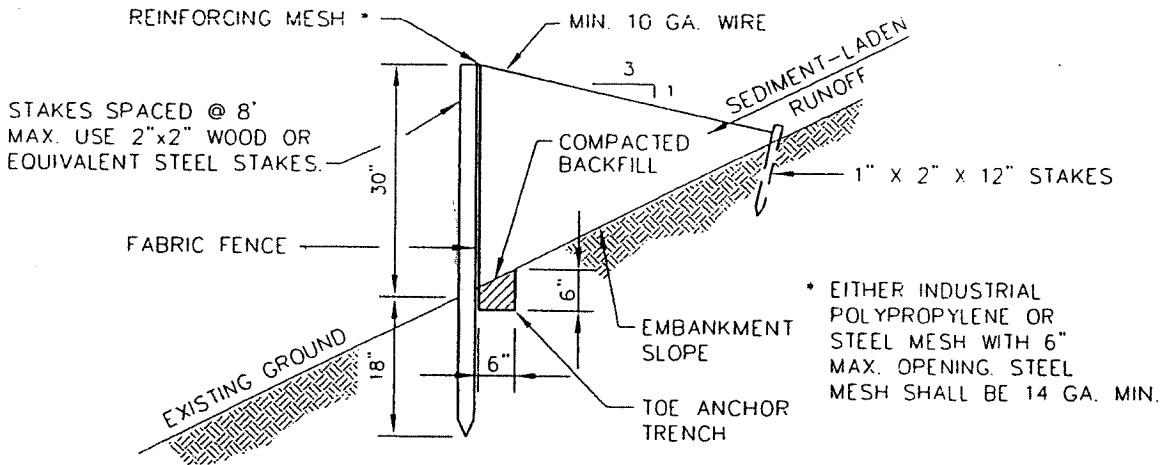

FILTER FABRIC FENCE MUST BE INSTALLED AT LEVEL GRADE. BOTH ENDS OF EACH FENCE SECTION MUST BE EXTENDED AT LEAST 8' UPSLOPE AT 45° TO THE MAIN FENCE ALIGNMENT.

SEDIMENT MUST BE REMOVED WHERE ACCUMULATIONS REACH 1/2 THE ABOVE GROUND HEIGHT OF THE FENCE.

ANY FENCE SECTION WHICH HAS BEEN UNDERMINED OR TOPPED MUST BE IMMEDIATELY REPLACED WITH A ROCK FILTER OUTLET. SEE DETAIL, YT 02270-1.

30" SILT FENCE DETAIL

NOTE: NOT TO SCALE

**YORK TOWNSHIP CONSTRUCTION & MATERIALS SPECIFICATIONS**

**YORK TOWNSHIP BOARD OF COMMISSIONERS**  
190 OAK ROAD  
DALLASTOWN, PENNSYLVANIA 17313  
TELEPHONE: 717-741-3861 FAX: 717-741-5009

**SILT BARRIER FENCE  
DETAIL**

DATE: 1/24/2005  
DRAWN BY: ARB  
CHK. BY:  
NO. YT 02270-5

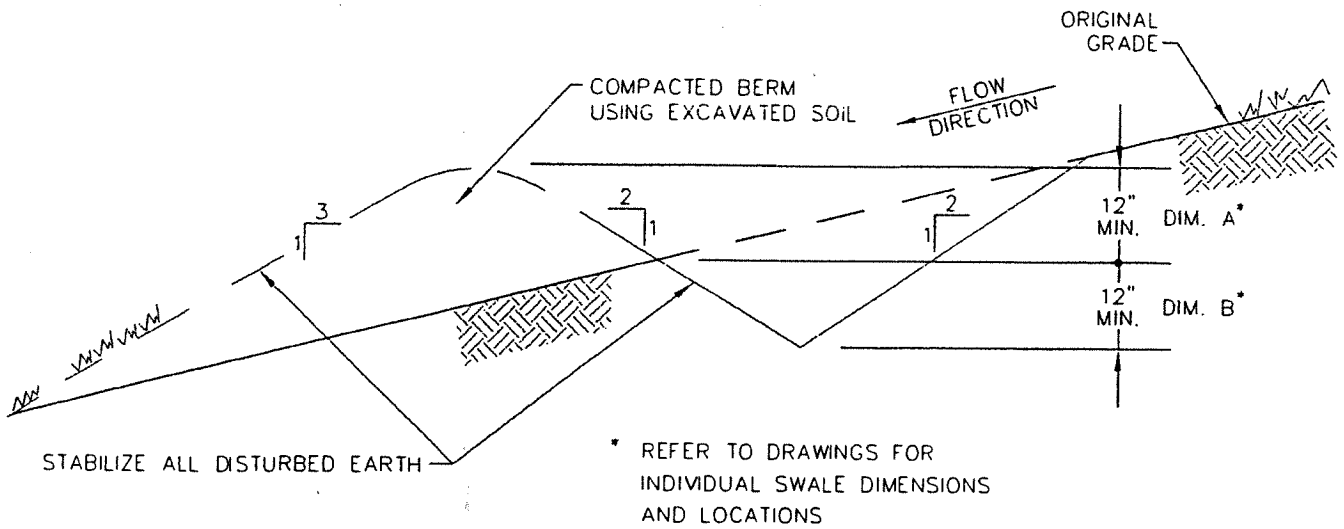

NOTE: NOT TO SCALE

YORK TOWNSHIP CONSTRUCTION & MATERIALS SPECIFICATIONS

YORK TOWNSHIP BOARD OF COMMISSIONERS  
 190 OAK ROAD  
 DALLASTOWN, PENNSYLVANIA 17313  
 TELEPHONE: 717-741-3861 FAX: 717-741-5009

TEMPORARY DIVERSION  
 SWALE DETAIL

DATE:	1/24/2005
DRAWN BY:	ARB
CHK. BY:	SKS
NO.	YT 02270-6

K:\09 1990003\dwg\YT02270-6.dwg, 1/27/2005 9:56:13 AM

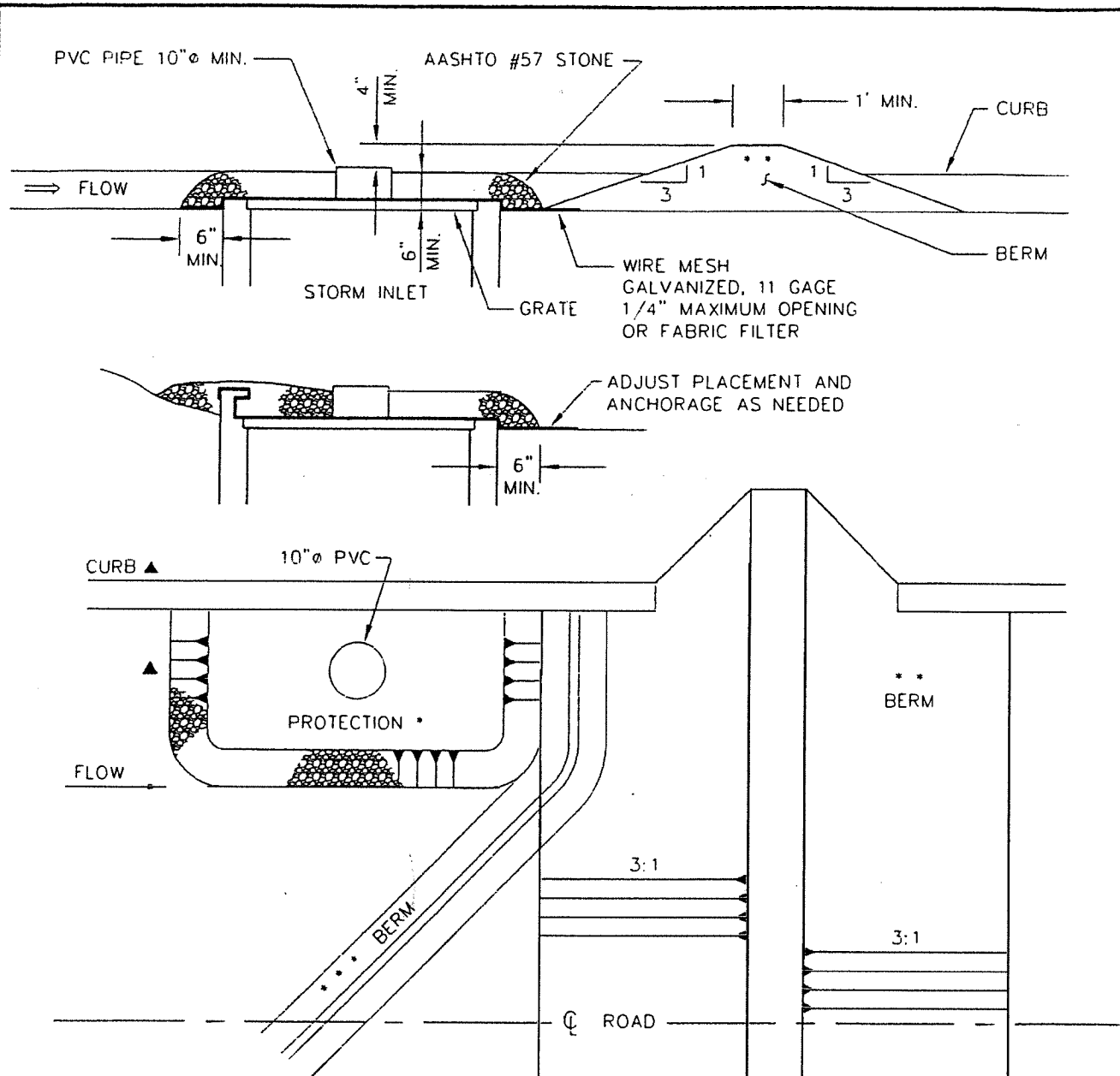

NOTE - MAXIMUM DRAINAGE AREA = 1 ACRE.

- \* STONE PROTECTION IS NOT REQUIRED FOR INLETS TRIBUTARY TO SEDIMENTATION BASINS AND SEDIMENT TRAPS. BERMS ARE REQUIRED FOR ALL INSTALLATIONS.
  - \*\* EARTHEN BERM TO BE MAINTAINED UNTIL ROADWAY IS STONED. ROAD SUBBASE BERM TO BE MAINTAINED UNTIL ROADWAY IS PAVED.
  - \*\*\* SIX INCH MINIMUM HEIGHT ASPHALT BERM TO BE MAINTAINED UNTIL ROADWAY SURFACE RECEIVES FINAL COAT.
  - ▲ IF NOT CURBED, CONSTRUCT BERM ON ALL SIDES OF INLET.
- NOTE: NOT TO SCALE

**YORK TOWNSHIP CONSTRUCTION & MATERIALS SPECIFICATIONS**

**YORK TOWNSHIP BOARD OF COMMISSIONERS**  
 190 OAK ROAD  
 DALLASTOWN, PENNSYLVANIA 17313  
 TELEPHONE: 717-741-3861 FAX: 717-741-5009

**STORM INLET PROTECTION DETAIL**

DATE: 1/24/2005  
 DRAWN BY: ARB  
 CHK. BY: SSS  
 NO. YI 02270-7

K:\09100003\dwg\YI02270-7.dwg, 1/27/2005 9:58:15 AM



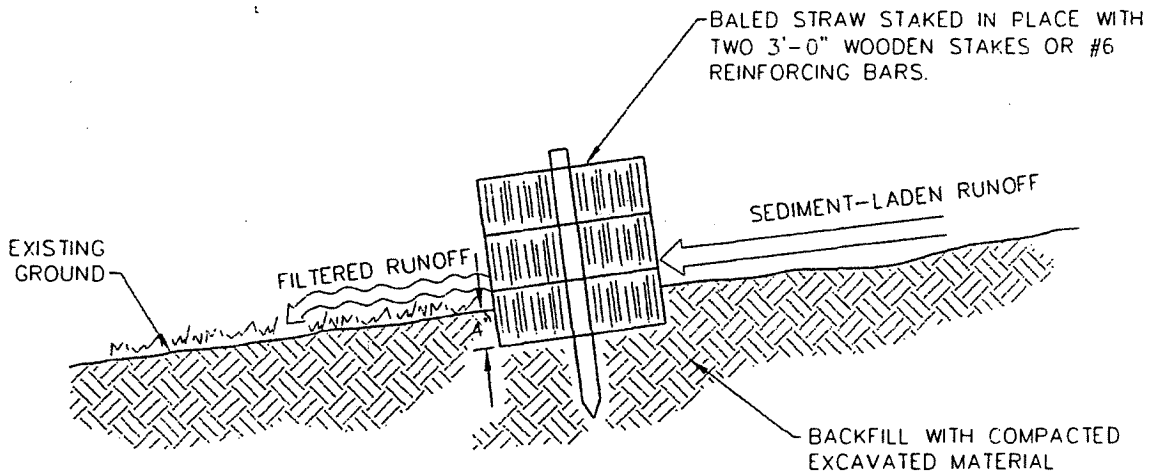

CROSS-SECTION OF PROPERLY  
INSTALLED STRAW BALE

NOTES:

STRAW BALE BARRIERS SHOULD NOT BE USED FOR MORE THAN 3 MONTHS.

STRAW BALE BARRIERS MUST BE PLACED AT LEVEL GRADES. BOTH ENDS OF THE BARRIER MUST BE EXTENDED AT LEAST 8 FEET UPSLOPE AT 45 DEGREES TO MAIN BARRIER ALIGNMENT.

SEDIMENT MUST BE REMOVED WHERE ACCUMULATIONS REACH 1/3 THE ABOVE GROUND HEIGHT OF THE BARRIER.

ANY SECTION OF STRAW BALE BARRIER WHICH HAS BEEN UNDERMINED OR TOPPED MUST BE IMMEDIATELY REPLACED WITH A ROCK FILTER OUTLET. SEE ROCK FILTER OUTLET DETAIL.

NOTE: NOT TO SCALE

YORK TOWNSHIP CONSTRUCTION & MATERIALS SPECIFICATIONS

YORK TOWNSHIP BOARD OF COMMISSIONERS  
 190 OAK ROAD  
 DALLASTOWN, PENNSYLVANIA 17313  
 TELEPHONE: 717-741-3861 FAX: 717-741-5009

STRAW BALE BARRIER  
 DETAIL

DATE:	1/24/2005
DRAWN BY:	ARB
CHK. BY:	<i>[Signature]</i>
NO	YT 02270-8

K:\091990003\dwg\T02270--8.dwg, 1/27/2005 9:58:16 AM

SECTION

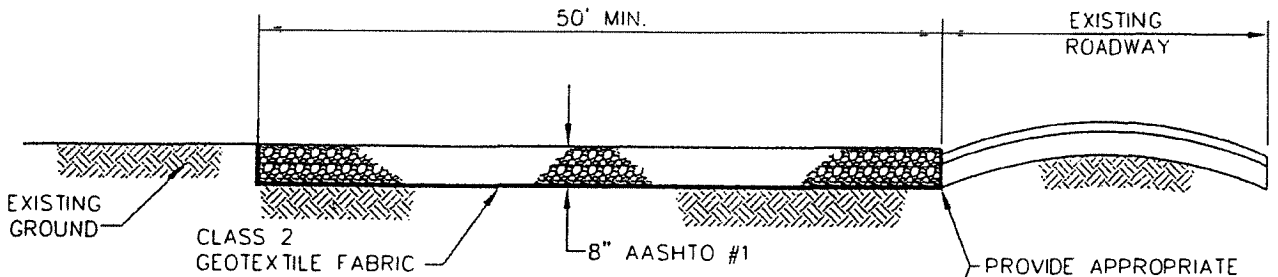

PLAN

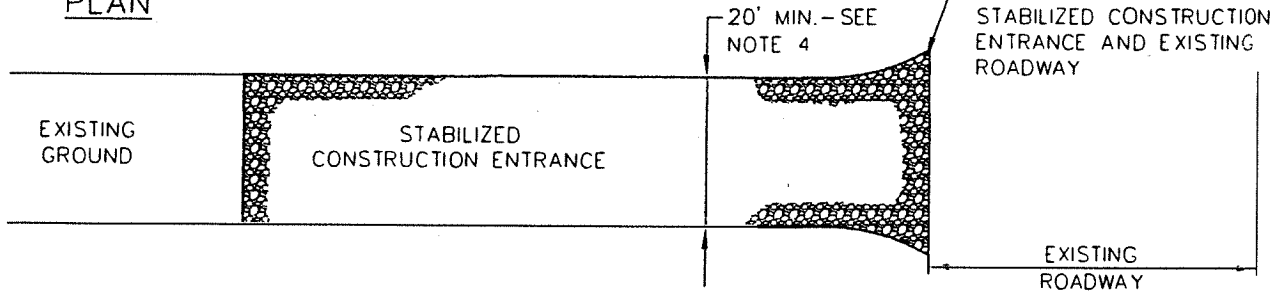

CONSTRUCTION SPECIFICATIONS

1. STONE SIZE - AASHTO #1.
2. LENGTH - AS REQUIRED TO BE EFFECTIVE, BUT NOT LESS THAN 50'.
3. THICKNESS - NOT LESS THAN 8".
4. WIDTH - FULL WIDTH OF ALL POINTS OF INGRESS OR EGRESS, BUT NOT LESS THAN 20'.
5. WASHING - WHEELS SHALL BE CLEAN PRIOR TO ENTRANCE ONTO EXISTING ROADWAY. WHEN WASHING IS REQUIRED IT SHALL BE DONE ON AN AREA STABILIZED WITH CRUSHED STONE WHICH DRAINS INTO AN APPROVED SEDIMENT TRAP OR SEDIMENT BASIN. ALL SEDIMENT SHALL BE PREVENTED FROM ENTERING ANY STORM DRAIN, DITCH, OR WATERCOURSE THROUGH USE OF SAND BAGS, GRAVEL, BOARDS, OR OTHER APPROVED METHODS.
6. MAINTENANCE - THE ENTRANCE SHALL BE MAINTAINED IN A CONDITION WHICH WILL PREVENT TRACKING OR FLOWING OF SEDIMENT ONTO EXISTING ROADWAY. THIS MAY REQUIRE PERIODIC TOP DRESSING WITH ADDITIONAL STONE AS CONDITIONS DEMAND AND REPAIR AND/OR CLEANOUT OF ANY MEASURES USED TO TRAP SEDIMENT. ALL SEDIMENT SPILLED, DROPPED, WASHED OR TRACKED ONTO EXISTING ROADWAYS MUST BE REMOVED IMMEDIATELY.

NOTE: NOT TO SCALE

**YORK TOWNSHIP CONSTRUCTION & MATERIALS SPECIFICATIONS**

**YORK TOWNSHIP BOARD OF COMMISSIONERS**  
 190 OAK ROAD  
 DALLASTOWN, PENNSYLVANIA 17313  
 TELEPHONE: 717-741-3861 FAX: 717-741-5009

**STABILIZED  
 CONSTRUCTION  
 ENTRANCE DETAIL**

DATE:	1/24/2005
DRAWN BY:	ARB
CHK. BY:	
NO.	YT 02270-9

K:\091990003\dwg\T02270-9.dwg, 1/27/2005 9:59:11 AM

K:\094990003\dwg\DETAILS - MAY 2015\DETAILS (original in autocad)\YT02270-10.dwg, 8/10/2015 9:03:01 AM

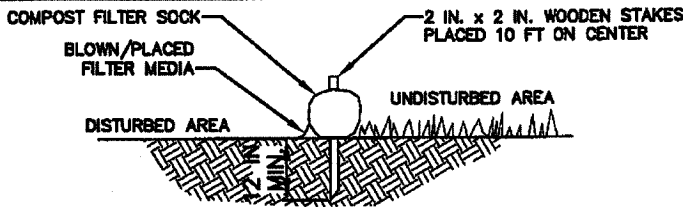

**SECTION**

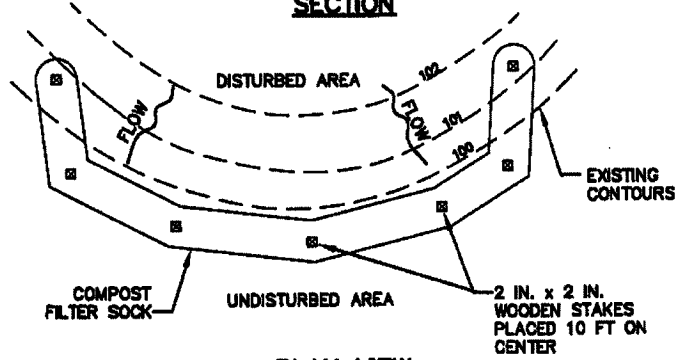

**PLAN VIEW**

**NOTES:**

SOCK FABRIC SHALL MEET STANDARDS OF TABLE 4.1 OF THE PA DEP EROSION CONTROL MANUAL. COMPOST SHALL MEET THE STANDARDS OF TABLE 4.2 OF THE PA DEP EROSION CONTROL MANUAL.

COMPOST FILTER SOCK SHALL BE PLACED AT EXISTING LEVEL GRADE. BOTH ENDS OF THE BARRIER SHALL BE EXTENDED AT LEAST 8 FEET UP SLOPE AT 45 DEGREES TO THE MAIN BARRIER ALIGNMENT. MAXIMUM SLOPE LENGTH ABOVE ANY BARRIER SHALL NOT EXCEED THAT SPECIFIED FOR THE SIZE OF THE SOCK AND THE SLOPE OF ITS TRIBUTARY AREA.

TRAFFIC SHALL NOT BE PERMITTED TO CROSS COMPOST FILTER SOCKS.

ACCUMULATED SEDIMENT SHALL BE REMOVED WHEN IT REACHES 1/2 THE ABOVE GROUND HEIGHT OF THE BARRIER AND DISPOSED IN THE MANNER DESCRIBED ELSEWHERE IN THE PLAN.

COMPOST FILTER SOCKS SHALL BE INSPECTED WEEKLY AND AFTER EACH RUNOFF EVENT. DAMAGED SOCKS SHALL BE REPAIRED ACCORDING TO MANUFACTURERS SPECIFICATIONS OR REPLACED WITHIN 24 HOURS OF INSPECTION.

BIODEGRADABLE COMPOST FILTER SOCKS SHALL BE REPLACED AFTER 6 MONTHS; PHOTODEGRADABLE SOCKS AFTER 1 YEAR. POLYPROPYLENE SOCKS SHALL BE REPLACED ACCORDING TO MANUFACTURERS RECOMMENDATIONS.

UPON STABILIZATION OF THE AREA TRIBUTARY TO THE SOCK, STAKES SHALL BE REMOVED. THE SOCK MAY BE LEFT IN PLACE AND VEGETATED OR REMOVED. IN THE LATTER CASE, THE MESH SHALL BE CUT OPEN AND THE MULCH SPREAD AS A SOIL SUPPLEMENT.

Material Type	3 mil HDPE	5 mil HDPE	5 mil HDPE	Multi-Filament Polypropylene (MFPP)	Heavy Duty Multi-Filament Polypropylene (HDMFPP)
Material Characteristics	Photo-degradable	Photo-degradable	Bio-degradable	Photo-degradable	Photo-degradable
Sock Diameters	12" 18"	12" 18" 24" 32"	12" 18" 24" 32"	12" 18" 24" 32"	12" 18" 24" 32"
Mesh Opening	3/8"	3/8"	3/8"	3/8"	1/8"
Tensile Strength		28 psi	28 psi	44 psi	202 psi
Ultraviolet Stability % Original Strength (ASTM D-155)	23% at 1000 hr.	23% at 1000 hr.		100% at 1000 hr.	100% at 1000 hr.
Minimum Functional Longevity	6 months	9 months	6 months	1 year	2 years
Two-ply systems					
Inner Containment Netting	HDPE biaxial net				
	Continuously wound Fusion-welded junctures 3/4" x 3/4" Max. aperture size				
Outer Filtration Mesh	Compenla Polypropylene Fabric (Woven layer and non-woven fleece mechanically fused via needle punch)				
	3/16" Max. aperture size				
Sock fabrics composed of burlap may be used on projects lasting 6 months or less.					

Organic Matter Content	80% - 100% (dry weight basis)
Organic Portion	Fibrous and elongated
pH	5.5 - 8.0
Moisture Content	35% - 55%
Particle Size	98% pass through 1" screen
Soluble Salt Concentration	5.0 dS/m (mmhos/cm) Maximum

NOTE: NOT TO SCALE

**YORK TOWNSHIP CONSTRUCTION & MATERIALS SPECIFICATIONS**

<b>YORK TOWNSHIP BOARD OF COMMISSIONERS</b> 190 OAK ROAD DALLASTOWN, PENNSYLVANIA 17313 TELEPHONE: 717-741-3861 FAX: 717-741-5009	<b>COMPOST FILTER SOCK DETAIL</b>		DATE: 5/20/2015
			DRAWN BY: BAM
			CHK. BY:
			NO. YT 02270-10

SECTION 02485

FINISH GRADING, SEEDING, AND SODDING

PART 1 GENERAL

1.01 DESCRIPTION

A. The work of this section includes, but is not limited to:

1. Placing topsoil
2. Soil conditioning
3. Finish grading
4. Seeding
5. Sodding
6. Mulching
7. Steep slope stabilization
8. Maintenance

B. Related work specified elsewhere:

1. Clearing and grubbing: Section 02100
2. Trenching, backfilling and compacting: Section 02221

C. Definitions: NONE

D. Applicable Standard Details: NONE

1.02 QUALITY ASSURANCE

A. Reference Standards:

1. Pennsylvania Department of Transportation (PennDOT), latest revision:  
Publication 408, Specifications
2. American Association of State Highway Transportation Officials (AASHTO):  
T194 Determination of Organic Matter in Soils by Wet Combustion
3. Pennsylvania Department of Agriculture
4. Others:

Agricultural Liming Materials Act of 1978, P.L.15  
Pennsylvania Seed Act of 1965, Act 187, as amended  
Pennsylvania Soil Conditioner and Plant Growth Substance Law, Act of December 1,  
1977, P.L. 258 No. 86 (3P.S. 68.2) as amended  
Rules for Testing Seeds of the Association of Official Seed Analysts  
Federal and State pesticide acts and registration requirements

- B. Sod Producer - Company specializing in sod production and harvesting with a minimum of 5 years experience.
- C. Sod Installer - Company specializing in performing this work with a minimum of 5 years experience.

### 1.03 SUBMITTALS

#### A. Samples:

1. Unless otherwise directed, furnish three strips of sod, 4-1/2 feet long by 12" wide, laid on 3" of topsoil and tamped in place. The samples shall be representative of the sod and workmanship to be provided. Include sod source location.

#### B. Certificates:

1. Unless directed otherwise, prior to use or placement of material, submit certifications of material composition of the following for approval:
  - a. Topsoil analysis
  - b. Fertilizer
  - c. Lime
  - d. Seed mixtures
  - e. Inoculant
  - f. Sod

### 1.04 JOB CONDITIONS - Section not utilized

## PART 2 PRODUCTS

### 2.01 TOPSOIL

- A. Having a pH of between 6.0 and 7.0; containing not less than 2% nor more than 10% organic matter as determined by AASHTO T194.
- B. Fertile friable loam, sand loam, or clay loam which will hold a ball when squeezed with the hand, but which will crumble shortly after being released.
- C. Free of clods, grass, roots, or other debris harmful to plant growth.
- D. Free of pests, pest larvae, and matter toxic to plants.

### 2.02 FERTILIZER

#### A. Basic Dry Formulation Fertilizer:

1. Analysis 10-20-20 and as defined by the Pennsylvania Soil Conditioner and Plant Growth Substance Law.

B. Starter Fertilizer:

1. Analysis 38-0-0 or 31-0-0 and as defined by the Pennsylvania Soil Conditioner and Plant Growth Substance Law.

2.03 LIME

- A. Raw ground limestone conforming to Publication 408, Section 804.2(a).

2.04 SEED

- A. Deliver seed fully tagged and in separate packages according to species or seed mix. Seed which has become wet, moldy, or otherwise damaged in transit or storage will not be accepted.
- B. Fresh, clean, dated material from the last available crop and within the date period specified, with a date of test not more than 9 months prior to the date of sowing. Percentage of pure seed present shall represent freedom from inert matter and from other seeds distinguishable by their appearance. All seeds will be subject to analysis and testing.

TABLE 1 - GRASS AND AGRICULTURAL SEEDS

<u>Species</u>	<u>Minimum</u>	<u>Maximum</u>	<u>Minimum Guaranteed Purity (Percent)</u>	<u>Weed Seed (Percent)</u>	<u>Guaranteed Germination (Percent)</u>
Kentucky Bluegrass ( <i>Poa pratensis</i> )			98	0.20	80
Perennial Ryegrass ( <i>Lolium perenne</i> , var. Pennfine) 98			0.15	90	
Tall Fescue ( <i>Festuca arundinacea</i> ), var. Kentucky 31)			98	0.15	85
Crownvetch ( <i>Coronilla varia</i> )			99	0.10	65
Creeping Red Fescue ( <i>Festuca rubra</i> , var. Pennlawn)			98	0.15	85
Annual Rye Grass ( <i>Lolium multiflorum</i> )			98	0.15	90
Timothy ( <i>Phleum pratense</i> )			98	0.25	85
Birdsfoot Trefoil mixture ( <i>Lotus corniculatus</i> )			98	0.10	80*
Redtop ( <i>Agrostis alba</i> )			92	0.15	80

\* Minimum 20% hardseed and 60% normal sprouts

2.05 SEED MIXTURES

A. See Seeding Restoration Table at end of this Section.

2.06 INOCULANT

A. Inoculate leguminous seed before seeding with nitrogen fixing bacteria culture prepared specifically for the species.

B. Do not use inoculant later than the date indicated by the manufacturer.

C. Protect inoculated seed from prolonged exposure to sunlight prior to sowing.

D. Reinoculate seed not sown within 24 hours following initial inoculation.

2.07 MULCHING MATERIALS

A. Mulches for seeded areas shall be one, or a combination of, the following:

1. Straw:

- a. Cured to less than 20% moisture content by weight.
- b. Contain no stems of tobacco, soybeans, or other coarse or woody material.
- c. Wheat or oat straw.

2. Wood Cellulose:

- a. No growth or germination inhibiting substances.
- b. Green, air dried. Packages not exceeding 100 pounds.
- c. Requirements:

Moisture Content:	12% $\nabla$ 3%
Organic Matter:	98.6% $\nabla$ 0.2% on the oven dried basis
Ash Content:	1.4% $\nabla$ 0.2%
Minimum Water-Holding Capacity:	1,000%

3. Mushroom Manure:

- a. Organic origin, free of foreign material larger than 2" and substances toxic to plant growth.
- b. Organic Matter: 20% minimum
- c. Water-Holding Capacity: 120% minimum
- d. pH: 6.0

B. Sewage sludge compost is not permitted.

2.08 SOD

A. Well-rooted Kentucky Bluegrass (*Poa pratensis*) sod containing a growth of not more than 10% of other grasses and clovers.

- B. Free from noxious weeds such as Bermuda grass, wild mustard, crab grass, and kindred grasses.
- C. Mow sod in the field to a height of not more than 2-1/2" within 5 days prior to lifting.
- D. Cut sod to a depth equal to the growth of the fibrous roots, but in no case less than 1-1/2", exclusive of grass and thatch. Do not cut sod when the ground temperature is below 32°F.
- E. Deliver sod to the project site within 24 hours after being cut and place sod within 36 hours after being cut. Do not deliver small, irregular, or broken pieces of sod. Do not deliver more sod than can be laid within 24 hours.
- F. During wet weather, allow sod to dry sufficiently to prevent tearing during handling and placing. During dry weather, moisten sod to ensure its vitality and to prevent dropping of the soil during handling. Sod which dries out will be rejected.

## 2.09 SLOPE STABILIZATION

- A. Erosion control mat (ECM) with appropriate seed mix.
- B. Erosion control and revegetation mat (ECRM) with appropriate seed mix.
- C. For all slopes 25% or steeper, use appropriate matting and seed mix.

## PART 3 EXECUTION

### 3.01 TIME OF OPERATIONS

- A. Spring Seeding:
  - 1. Preliminary operations for seed bed preparation may commence as soon after February 15 as ground conditions permit.
- B. Fall Seeding:
  - 1. Preliminary operations for seed bed preparation may commence after July 15.

### 3.02 FINISH GRADING

- A. Preparation of Subgrade:
  - 1. "Hard pan" or heavy shale:
    - a. Plow to a minimum depth of 6".
    - b. Loosen and grade by harrowing, discing, or dragging.
    - c. Hand rake subgrade. Remove rocks over 2" in diameter and other debris.
  - 2. Loose loam, sandy loam, or light clay:
    - a. Loosen and grade by harrowing, discing, or dragging.



- b. Hand rake subgrade. Remove rocks over 2" in diameter and other debris.

B. Placing Topsoil:

1. Place topsoil and spread over the prepared subgrade to obtain the required depth and grade elevation. Compact with a roller having not more than 65 pounds per roller foot width to a final compacted thickness of not less than 4".
2. Hand rake topsoil and remove all materials unsuitable or harmful to plant growth.
3. Do not place topsoil when the subgrade is frozen, excessively wet, or extremely dry.
4. Do not handle topsoil when frozen or muddy.

C. Tillage:

1. After seed bed areas have been brought to proper compacted elevation, thoroughly loosen to a minimum depth of 4" by discing, harrowing, or other approved methods. Do not work topsoiled areas when frozen or excessively wet.
2. Liming:
  - a. Distribute lime uniformly at the specified rates.
  - b. Thoroughly incorporate into the topsoil to a depth of 4".
  - c. Incorporate as a part of the tillage operation.
3. Basic Fertilizer:
  - a. Distribute basic fertilizer uniformly at the specified rate.
  - b. Thoroughly incorporate into the topsoil to a depth of 4".
  - c. Incorporate as a part of tillage operation.

D. Finish Grading:

1. Remove unsuitable material larger than 1/2" in any dimension.
2. Uniformly grade surface to the required contours without the formation of water pockets.
3. Rework areas which puddle by the addition of topsoil and starter fertilizer and rake.

3.03 SEEDING

- A. Distribute starter fertilizer at the specified rates.
- B. Incorporate starter fertilizer into the upper 1" of soil.
- C. Uniformly sow specified seed mix by use of approved hydraulic seeder, power-drawn drill, power-operated seeder, or hand-operated seeder. Do not seed when winds are over 15 mph.
- D. Upon completion of sowing, cover seed to an average depth of 1/4" by hand raking or approved mechanical methods.
- E. Mulch immediately after seeding, using one of the following methods:
  1. Place straw mulch in a continuous blanket at a minimum rate of 1,200 pounds per 1,000 square yards.

- a. Anchor straw mulch by use of twine, stakes, wire staples, paper, or plastic nets.
  - b. Emulsified asphalt may be used for anchorage provided it is applied uniformly at a rate not less than 31 gallons per 1,000 square yards.
  - c. Chemical mulch binders may be used for anchorage if they are applied uniformly at the manufacturer's recommended rate.
  - d. Chemical mulch binders or a light covering of topsoil may be used for anchorage when the size of the area precludes the use of mechanical equipment.
2. Apply wood cellulose fiber hydraulically at a rate of 320 pounds per 1,000 square yards. Incorporate as an integral part of the slurry after seed and soil supplements have been thoroughly mixed.
  3. Spread mushroom manure uniformly to a minimum depth of ½" or to the depth indicated on the drawings.
- F. When mulch is applied to grass areas by blowing equipment, the use of cutters in the equipment will be permitted to the extent that a minimum of 95% the mulch is 6" or more in length. For cut mulches applied by the blowing method, achieve a loose depth in place of not less than 2".
- G. When mulching by the asphalt mix method, apply the mulch by blowing. Spray the asphalt binder material into the mulch as it leaves the blower. Apply the binder to the mulch in the proportion of 1.5 to 2.0 gallons per 45 pounds of mulch.
1. Protect structures, pavements, curbs, and walls to prevent asphalt staining.
  2. Erect warning signs and barricades at intervals of 50 feet or less along the perimeter of the mulched area.
  3. Do not spray asphalt and chemical mulch binders onto any area within 100 feet of a stream or other body of water.

### 3.04 SODDING

- A. Prior to sod placement, complete finish grading and moisten prepared surface to received sod.
- B. Do not place sod when the temperature is lower than 32°F.
- C. Place sod by hand with tight joints and no overlap. Transverse joints shall be broken or staggered.
- D. Place sod so that the top of the sod is flush with the surrounding grade.
- E. Use of tools which damage the sod or dumping of sod from vehicles will not be permitted.
- F. Water sod to the saturation point immediately after placement.
- G. After watering, tamp with an approved tamper to close all joints and insure close contact between sod and sod bed. After tamping, the sod shall present a smooth, even surface free from bumps and depressions. If so directed, use a light roller, weighing not more than 65 pounds per foot of roller width to complete firming and smoothing the sod.

- H. When placing sod in ditches, place the strip with the long dimension at right angles to the flow of water. At any point where water will start flowing over a sodded area, the upper edge of the sod strips shall be turned into the soil below the adjacent area and a layer of compacted earth placed over this juncture to conduct the water over the edge of the sod.
- I. In ditches and on slope areas, stake each strip of sod securely with at least 1 wood stake for each 2 square feet of sod. Stakes shall be ½" by 1" with a length of 8" to 12". Drive stakes flush with the top of the sod, with the long face parallel to the slope contour.

3.05 STEEP SLOPES

- A. Prepare final graded surface, topsoil and designated seed mix and mulch.
- B. Install matting with appropriate anchoring devices. Follow manufacturer's installation instructions.

3.06 MAINTENANCE

- A. Maintenance includes watering, weeding, cleanup, edging and repair of depressions, washouts or gullies.
- B. Those areas which do not show a prompt catch of grass within 14 days of seeding or sodding shall be reseeded or resodded until complete grass catch occurs.
- C. Maintain sodded areas for 3 months from date of substantial completion, mow to maintain maximum height of 2-1/2" or as specified on drawings.

SEEDING RESTORATION TABLE

<u>RESTORATION CONDITION</u>	<u>TOPSOIL</u>	<u>LIME*</u>	<u>BASIC FERTILIZER</u>	<u>STARTER FERTILIZER</u>	<u>SEED MIX &amp; SOWING RATE (% BY WEIGHT)</u>
Temporary Cover (PennDOT E)	N/A	1 Ton/Acre	5-5-5 @ 1000# /Acre	N/A	100% Annual Ryegrass Sow 10# per 1,000 Sq. Yds. March 15 thru October 15
Roadside; Non-mowed (PennDOT D)	Yes	800# per 1000 Sq. Yds.	10-20-20 @ 140# per 1000 Sq. Yds.	38-0-0 @ 50# per 1000 Sq. Yds. or 31-0-0 @ 61# per 1000 Sq. Yds.	70% Tall Fescue 30% Creeping Red Fescue Sow 21# per 1000 Sq. Yds. Mar. 15 thru May/Aug. thru Oct. 15
Roadside; Mowed (PennDOT B)	Yes	800# per 1000 Sq. Yds.	10-20-20 @ 140# per 1000 Sq. Yds.	38-0-0 @ 50# per 1000 Sq. Yds. or 31-0-0 @ 61# per 1000 Sq. Yds.	50% Kentucky Bluegrass 30% Creeping Red Fescue 20% Perennial Ryegrass Sow 21# per 1000 Sq. Yds. Mar. 15 thru May/Aug. thru Oct. 15
Bank Areas (PennDOT C)	Yes	800# per 1000 Sq. Yds.	No	38-0-0 @ 50# per 1000 Sq. Yds. or 31-0-0 @ 61# per 1000 Sq. Yds.	45% Crownvetch 55% Annual Ryegrass Sow 9# per 1000 Sq. Yds. Anytime except Sept. and Oct.
Bank Areas (PennDOT W)	Yes	No	No	38-0-0 @ 50# per 1000 Sq. Yds. or 31-0-0 @ 61# per 1000 Sq. Yds.	70% Tall Fescue 20% Birdsfoot Trefoil Mixture 10% Redtop Sow 10.5# per 1000 Sq. Yds.
Lawns (PennDOT B)	Yes	800# per 1000 Sq. Yds.	10-20-20 @ 140# per 1000 Sq. Yds.	38-0-0 @ 50# per 1000 Sq. Yds. or 31-0-0 @ 61# per 1000 Sq. Yds.	50% Kentucky Bluegrass 30% Pennlawn Red Fescue 20% Perennial Ryegrass Sow 21# per 1000 Sq. Yds. Mar. 15 thru May/Aug. thru Oct. 15
Open Fields; Non-Cultivated, Pasture	No	No	No	38-0-0 @ 50# per 1000 Sq. Yds. or 31-0-0 @ 61# per 1000 Sq. Yds.	100% Timothy Sow 10# per 1000 Sq. Yds. Mar. thru May/Aug. thru Sept.

\*Unless lesser rate indicated by soils tests

SEEDING RESTORATION TABLE

<u>RESTORATION CONDITION</u>	<u>TOPSOIL</u>	<u>LIME*</u>	<u>BASIC FERTILIZER</u>	<u>START FERTILIZER</u>	<u>SEED MIX &amp; SOWING RATE (% BY WEIGHT)</u>
Open Fields; Cultivated	No	No	No	38-0-0 @ 50# per 1000 Sq. Yds. or 31-0-0 @ 61# per 1000 Sq. Yds.	100% Annual Ryegrass Sow 10# per 1,000 Sq. Yds. March 15 thru Oct. 15
Woods; Sparse	No	No	10-20-20 @ 140# per 1000 Sq. Yds.	38-0-0 @ 50# per 1000 Sq. Yds. or 31-0-0 @ 61# per 1000 Sq. Yds.	100% Red Fescue Sow 36# per 1000 Sq. Yds. Mar. 15 thru May/Aug. thru Oct. 15
Sodding	Yes	800# per 1000 Sq. Yds.	10-20-20 @ 140# per 1000 Sq. Yds.	N/A	N/A
Basin/Channels	Yes	No	10-20-20 @ 140# Per 1000 Sq. Yds.	38-0-0 @ 50# per 1000 Sq. Yds or 31-0-0 @ 61# per 1000 Sq. Yds.	50% Tall Fescue, 25% Rough Bluegrass, 15% Reed Canary Grass, 10% Redtop

\*Unless lesser rate indicated by soils test

END OF SECTION

SECTION 02500

BITUMINOUS PAVING AND SURFACING

PART 1 GENERAL

1.01 DESCRIPTION

A. The work of this section includes, but is not limited to:

1. Bituminous concrete base course construction.
2. Placement and compaction of bituminous binder and wearing surface.
3. Placement of bituminous seal coat and surface treatment.
4. Surface preparation.

B. Related work specified elsewhere:

- |  |               |
|--|---------------|
| 1. Clearing and grubbing:                          | Section 02100 |
| 2. Site excavation and placement of fill material: | Section 02210 |
| 3. Roadway excavation, fill, and compaction:       | Section 02230 |
| 4. Pavement markings:                              | Section 02760 |
| 5. Roadway signing:                                | Section 02891 |

C. Definitions: NONE

D. Applicable Standard Details:

- YT 02500-1 Local Streets with Curbs Typical Cross Section (Parking Both Sides)
- YT 02500-2 Street Widening Detail
- YT 02500-3 Pavement Base Drain Detail
- YT 02500-4 Residential Local Street (with reinforced shoulders) Cross Section (Parking Both Sides)

1.02 QUALITY ASSURANCE

A. Reference Standards:

1. Pennsylvania Department of Transportation (PennDOT), latest revision:

- Publication 408, Specifications
- Publication 213, Temporary Traffic Control Guidelines
- Publication 27, Specification for Bituminous Mixtures (Bulletin 27)
- Publication 37, Specification for Bituminous Materials (Bulletin 25)
- Publication RR-459, Occupancy of Highway by Utilities

2. American Society for Testing and Materials (ASTM):

- D2950 Test Method for Density of Bituminous Concrete in Place by Nuclear Methods

B. Inspections:

1. Inspection by the Municipality will, at a minimum, be made of the subgrade prior to placement of the base course, and of the base course prior to placement of the binder surface.

1.03 SUBMITTALS

A. Certification:

1. Submit certification from bituminous and aggregate suppliers attesting that materials conform to Publication 408, Specifications.
2. Submit bituminous concrete mix design for approval.
3. Provide PennDOT certifications (CS-4171) with each load delivered to the job site.

1.04 JOB CONDITIONS

A. Control of Traffic:

1. Take measures to control traffic during paving operations. Do not allow traffic on newly paved areas until adequate stability and adhesion have been attained and the material has cooled to 140° F or less.
2. Employ traffic control measures in accordance with Publication 213 Temporary Traffic Control Guidelines.

B. Protect existing utilities as described in Section 02210.

PART 2 PRODUCTS

2.01 BITUMINOUS MATERIALS AND AGGREGATES

- A. All bituminous materials and aggregates used in base course construction, paving, and resurfacing are designated in these specifications by, and shall conform to, the applicable portions of the Publication 408 Specifications. The coarse aggregate used in bituminous wearing surfaces shall have the following aggregate Skid Resistance Level (SRL) letter designation based on the current Average Daily Traffic (ADT) for resurfacing or anticipated initial daily traffic on new facilities:

<u>ADT</u>	<u>SRL</u>	<u>ALTERNATIVES</u>
20,000 and Above	E	None
5,000 to 20,000	H	E, H, Blend of E and M, Blend of E and G
3,000 to 5,000	G	E, H, G, Blend of H and M, Blend of E and L
1,000 to 3,000	M	E, H, G, M, Blend of H and L, Blend of G and L, Blend of E and L
1,000 and Below	L	Any

Note: All blends are 50% by mass and shall be accomplished by an approved method.

- B. All Superpave (HMA) mixtures shall conform to applicable portions of Publication 408 Specifications. Aggregate shall be provided by approved sources and have the SRL designation as specified above. All mixtures will be petroleum grade PG 64-22 and 1.0 million ESALS unless specified otherwise by the Municipality. Submit mixture design for base, binder, and wearing to Municipality for approval prior to placement.

## 2.02 SEALANTS

- A. Rubberized joint sealing material (ASTM D3405 or modified AASHTO M173) for transverse; longitudinal or other joints at utilities and curbs.
- B. Poly Flex II or equivalent may be used with prior approval of Township Engineer.

## PART 3 EXECUTION

### 3.01 BASE COURSES

- A. Bituminous Concrete Base Course - Where indicated on the drawings or requested by the Municipality, construct bituminous concrete base course to compacted depth in accordance with Publication 408 Specifications, Section 350. Proof roll base course to satisfaction of the Municipality. Municipality shall approve crushed aggregate base course prior to placement of BCBC.
- B. Superpave Asphalt - Where indicated on the drawings, construct HMA base course to compacted depth in accordance with Publication 408, Section 309.

### 3.02 PREPARATION OF EXISTING PAVEMENT SURFACE

- A. Clean street surface of all dust, debris, loose stone, earth, or other deleterious material by means of hand brooms or approved power brooms.
- B. Scarify areas shown on the drawings. Where the existing base is judged inadequate by the Municipality, construct new base of the required type shown on Standard Details.



- C. Patch holes and depressions greater than one inch and less than four inches with 19 mm superpave HMA binder material, compacted in layers not exceeding two inches after compaction.
- D. Holes greater than four inches in depth shall be sawed back to sound pavement, and patched with a minimum of six inches of crushed aggregate base course and two inches of 19 mm or superpave HMA binder material.
- E. Apply tack coat prior to overlaying existing pavement in accordance with Publication 408 Specifications, Section 460.
- F. Milling of existing bituminous pavement shall be performed in accordance with Publication 408, Section 491 to the depth and limits specified in the drawings.
  - 1. Saw cut all edges at intersections with streets and driveways and at the limits of work.
  - 2. Millings must be disposed of properly.
  - 3. Supply all water as needed.
- G. Fabric Requirement: Mirafi MPV 600 (or equal). This fabric must be installed per the manufacturer's instructions between the binder and wearing course no later than five years after the binder mat was placed.

### 3.03 SURFACE COURSES

- A. Bituminous Surface Course 9.5 mm Superpave HMA
  - 1. Construct binder course meeting the requirements of Publication 408 Specifications to compacted depth shown on Standard Details.
  - 2. Construct wearing surface meeting the requirements of Publication 408 Specifications, Section 420 to the compacted depth shown on Standard Details. Apply tack coat on existing paved surfaces in accordance with Publication 408, Section 401.
- B. Compaction
  - 1. Compact by rolling with steel-wheel, vibration or pneumatic tire rollers (minimum GVW = 5 tons) or a combination of these to obtain specified layer thickness and until non-movement of material under compaction equipment is achieved, unless other density requirements required by the Municipality.
  - 2. The roller pattern and speed shall be monitored by the Municipality to avoid roller marks, pattern segregation and displacement of hot mixtures.
- C. Bituminous Seal Coat (single application)
  - 1. Construct bituminous seal coat in accordance with Publication 408 Specifications, Section 470.
- D. Bituminous Surface Treatment (double application)
  - 1. Construct bituminous surface treatment in accordance with Publication 408 Specifications, Section 480.
- E. Superpave Asphalt

1. HMA Binder Course - Construct HMA binder course to the compacted depth shown on the drawings and Publication 408, Section 409.
2. HMA Wearing Course - Construct HMA wearing course to the compacted depth shown on the drawings and Publication 408, Section 409.
3. HMA Base Course - Where required, construct in accordance with Publication 408, Section 309.

### 3.04 JOINTS

#### A. Notch

The edge of an overlay shall be milled to a depth of 2" for the entire length of the joint and the detached material removed to a minimum notch width of 12". Notch shall be skewed a minimum 6:1 unless otherwise noted. The vertical face must be painted with E-6, E-8 or the same asphalt material used in mix design (Publication 408, Section 401.3(j)).

#### B. Sealing

All joints shall be sealed rubberized joint sealing material. When wearing course is placed adjacent to curb to form bituminous gutter, seal with hot bituminous material of the class and type designated for wearing course and extend to 6 inches from the curb, applied evenly. The use of PG 64-22 may be permitted when approval is obtained from the Township Engineer.

### 3.05 FIELD QUALITY CONTROL

#### A. Surface Tolerance of Base Course.

After the base course has been completed as specified, the surface smoothness shall be checked with approved templates, string lines, or straightedges.

1. Templates. The Contractor shall furnish and use approved templates of required length and cut to the required crown of the finished surface of the base course, for checking the crown and contour thereof. The templates shall be equipped with metal or other approved vertical extensions attached to each end, so that the bottom of the template will be at the elevation of the top of the aggregate. At least 3 such templates shall be furnished, and used at intervals of not more than 25 feet.
2. String Lines. String lines, for controlling the finished elevation of the base course, shall be furnished with ample supports and offset along each side of the base course, and shall be maintained until all irregularities have been satisfactorily corrected.
3. Straightedges. Approved straightedges 10 feet in length shall also be furnished and used for testing longitudinal irregularities in the surface of the base course.

Any surface irregularities that exceed 1 inch shall be remedied by removing or adding bituminous material as required, after which the entire area, including the surrounding surface, shall be rolled until satisfactorily compacted.

B. Tests for Depth of Finished Base Course.

During the progress of the work, the depth of the base course will be measured by the Municipality and unsatisfactory work shall be repaired, corrected, or replaced. The Municipality will not be liable for payment for any excess depth of base course.

1. The depth will be determined by cutting or coring holes to the full depth of the completed base course. One depth measurement may be required for each 1500 square yards, or less, of completed base course. Any section in which the depth is  $\frac{1}{2}$  inch or more deficient in specified depth, shall be satisfactorily corrected at no expense to the Municipality.
2. All test holes shall be backfilled with similar material and satisfactorily compacted by and at the expense of the Contractor. This operation shall be performed under the observation of the Municipality who will check the depth for record purposes.

C. Surface Tolerance of Wearing Course.

After the wearing course has been completed as specified, the surface smoothness shall be checked with straightedges.

1. Straightedges. Approved straightedges 10 feet in length shall be furnished and used for testing longitudinal irregularities in the surface of the wearing course.

Any surface irregularities that exceed  $\frac{3}{16}$  inch shall be remedied by removing or adding wearing material as required, after which the entire area, including the surrounding surface, shall be rolled until satisfactorily compacted.

D. Tests for Depth of Finished Wearing Course.

During the progress of the work, the depth of the wearing course may be measured by the Municipality and unsatisfactory work shall be repaired, corrected, or replaced. The Municipality will not be liable for payment for any excess depth of wearing course.

1. The depth will be determined by cutting or coring holes to the full depth of the completed wearing course. Test holes to be excavated by the Contractor at no expense to the Municipality. One depth measurement may be required for each 1500 square yards of completed wearing course. Any section in which the depth is  $\frac{1}{4}$  inch or more deficient in specified depth, shall be satisfactorily corrected at no expense to the Municipality.
2. All test holes shall be backfilled with similar material and satisfactorily compacted by and at the expense of the Contractor. This operation shall be performed under the observation of the Municipality who will check the depth for record purposes.

END OF SECTION

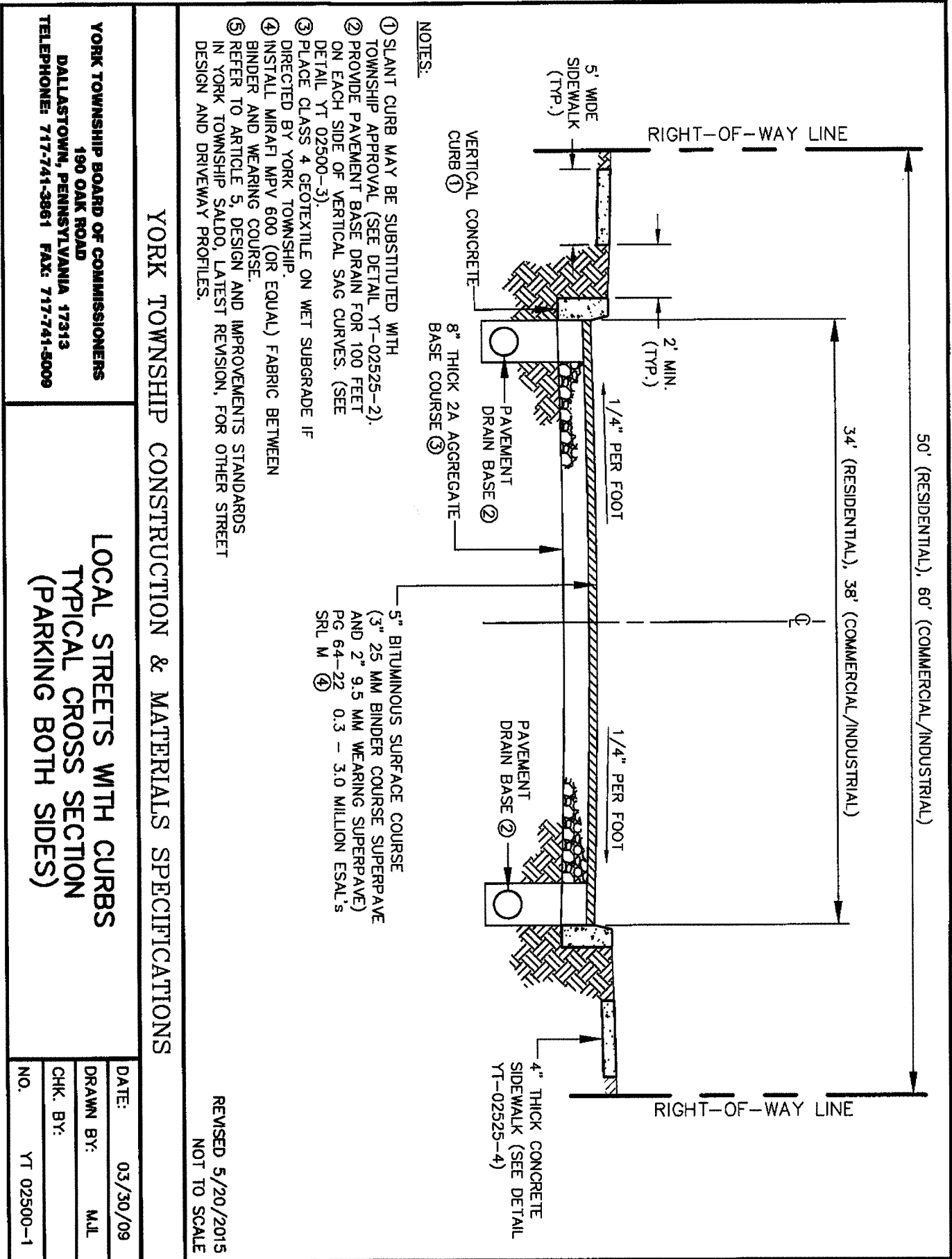

MILL AND OVERLAY TO EXISTING CENTERLINE AT DIRECTION OF TOWNSHIP. IF YORK TOWNSHIP DETERMINES THAT THE EXISTING ROAD BASE IS UNSATISFACTORY, (PER SECTION 02500) RECONSTRUCT 1/2 WIDTH OF ROAD FOR ENTIRE LENGTH OF PROJECT FRONTAGE.

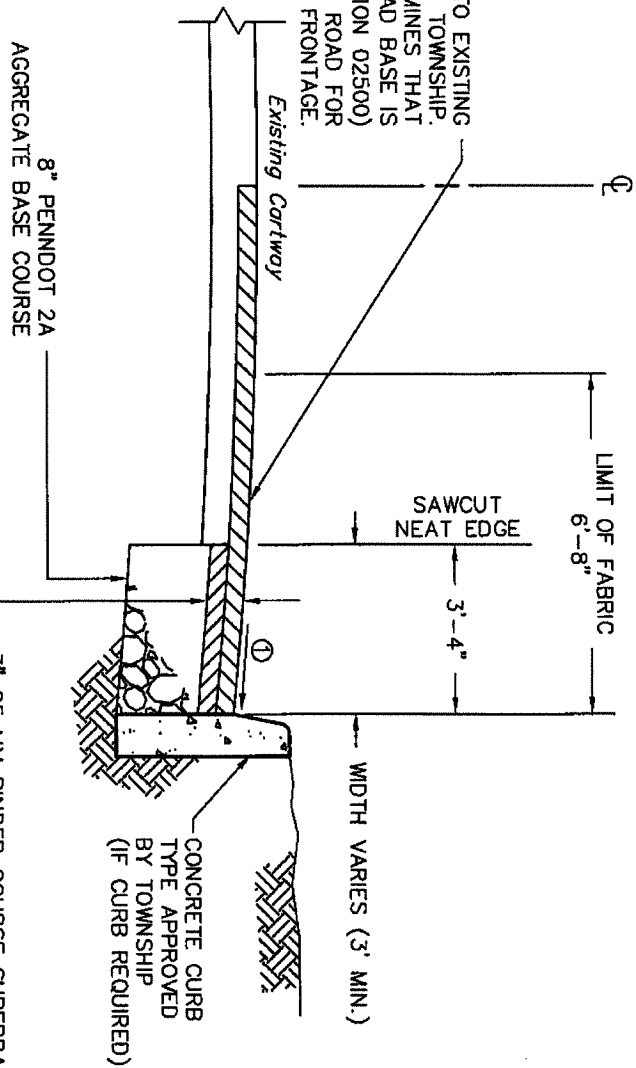

**NOTES:**

- ① 2% MINIMUM, MATCH EXISTING CROSS-SLOPE IF GREATER THAN 2%
- ② INSTALL FABRIC BETWEEN BINDER AND WEARING COURSE

REVISED 5/20/2015

NOT TO SCALE

**YORK TOWNSHIP CONSTRUCTION & MATERIALS SPECIFICATIONS**

**YORK TOWNSHIP BOARD OF COMMISSIONERS**

**190 OAK ROAD**

**DALLASTOWN, PENNSYLVANIA 17313**

**TELEPHONE: 717-741-3861 FAX: 717-741-5009**

**STREET WIDENING DETAIL**

DATE: 03/30/09

DRAWN BY: MJL

CHK. BY:

NO. YT 02500-2REV

K:\094990003\dwg\DETAILS - MAY 2015\DETAILS (original in autocadd)\YT02500-3REV.DWG, 8/10/2015 7:58:46 AM

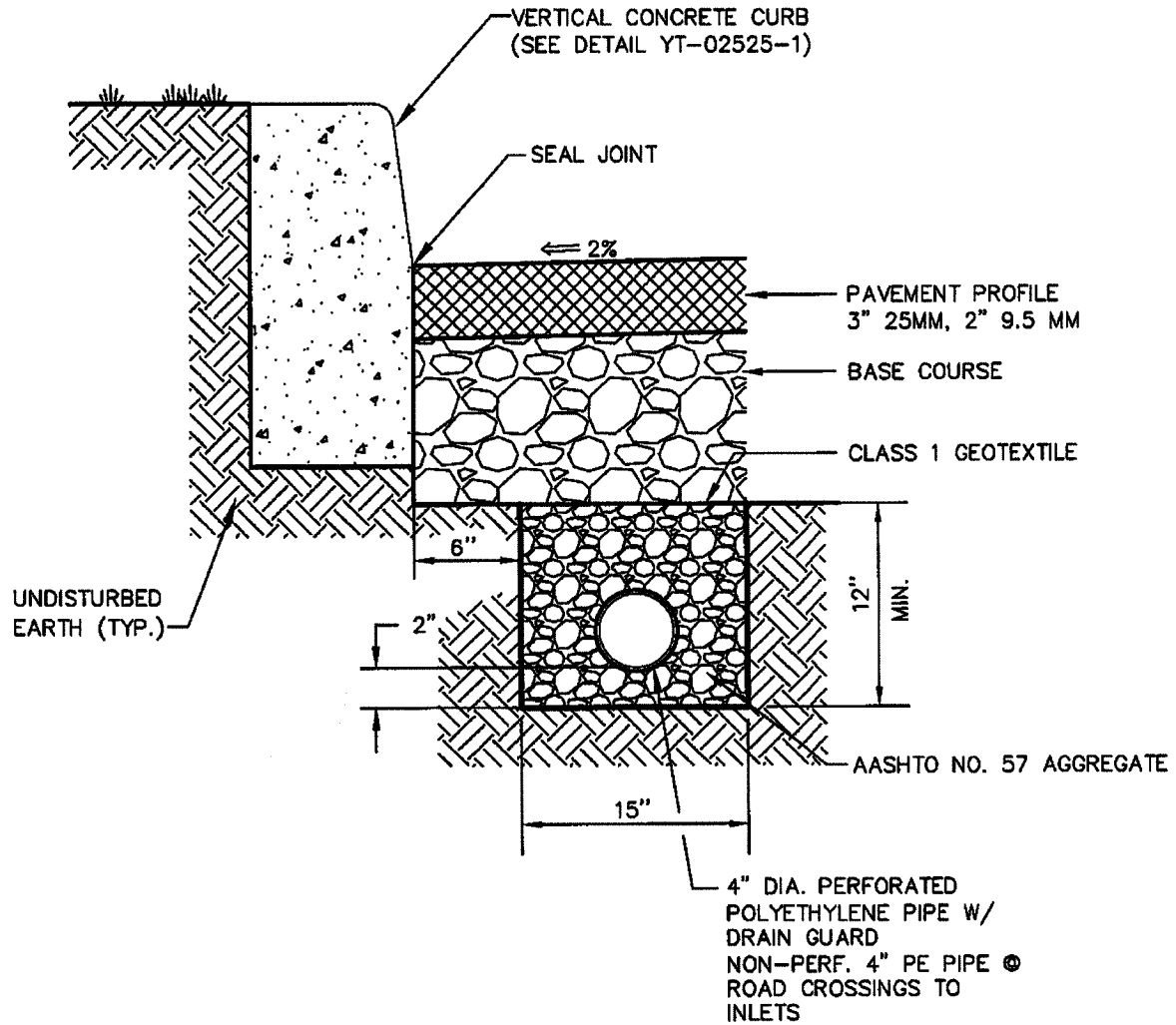

REVISED 5/20/2015  
NOT TO SCALE

YORK TOWNSHIP CONSTRUCTION & MATERIALS SPECIFICATIONS

YORK TOWNSHIP BOARD OF COMMISSIONERS  
190 OAK ROAD  
DALLASTOWN, PENNSYLVANIA 17313  
TELEPHONE: 717-741-3861 FAX: 717-741-5009

PAVEMENT  
BASE DRAIN  
DETAIL

DATE: 04/03/09

DRAWN BY: MJL

CHK. BY:

NO. YT 02500-3REV

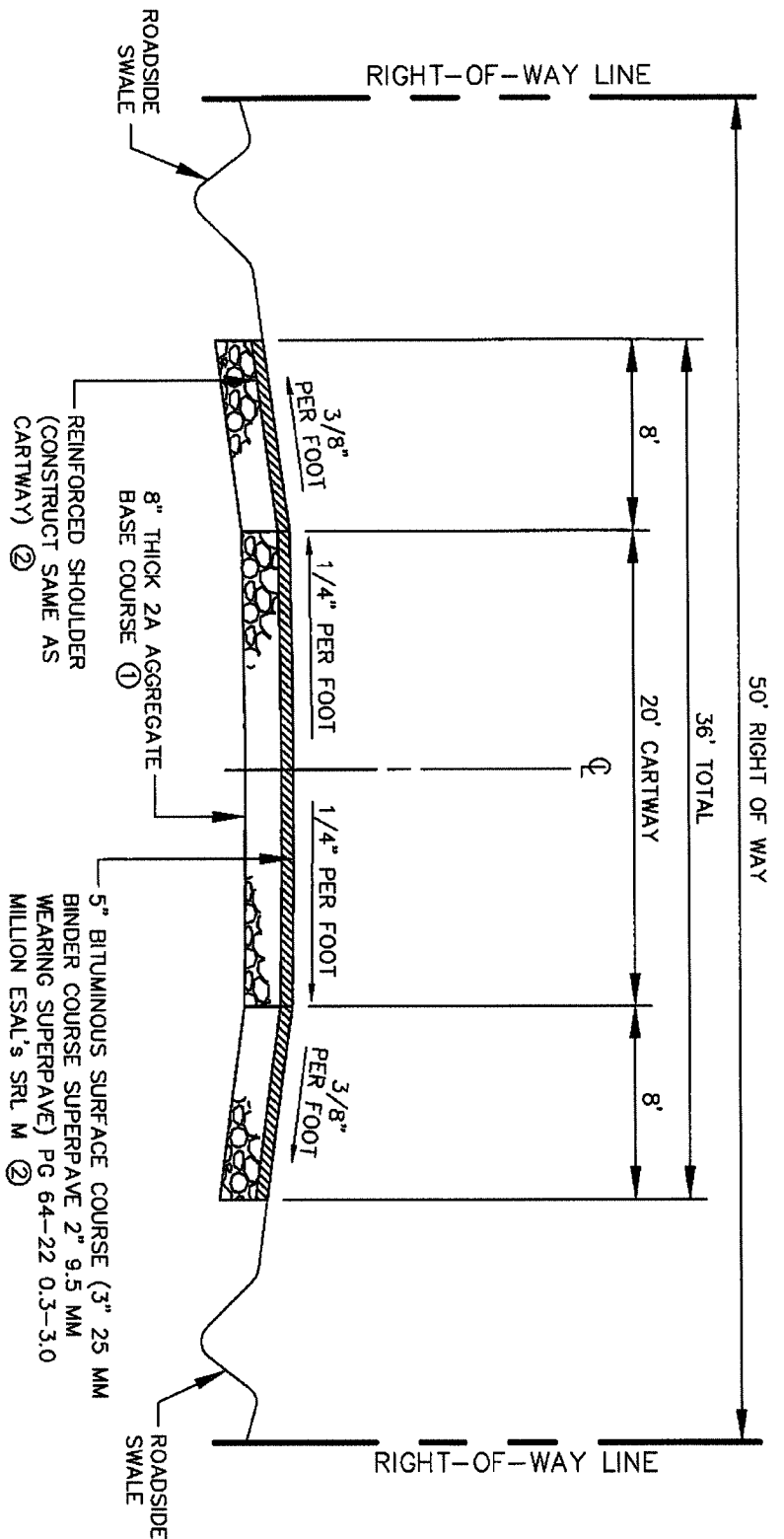

- NOTES:**
- 1 PLACE CLASS 4 GEOTEXTILE ON WET SUBGRADE IF DIRECTED BY TOWNSHIP
  - 2 INSTALL MIRAFI MPV 600 (OR EQUAL) FABRIC BETWEEN BINDER AND WEARING COURSE.
  - 3 REFER TO ARTICLE 5, DESIGN AND IMPROVEMENTS STANDARDS IN YORK TOWNSHIP SALDO, LATEST REVISION, FOR OTHER STREET DESIGN AND DRIVEWAY PROFILES.

REVISED 5/20/2015  
NOT TO SCALE

**YORK TOWNSHIP CONSTRUCTION & MATERIALS SPECIFICATIONS**

**RESIDENTIAL LOCAL STREET  
(WITH REINFORCED SHOULDERS)  
CROSS SECTION  
(PARKING BOTH SIDES)**

**YORK TOWNSHIP BOARD OF COMMISSIONERS**  
190 OAK ROAD  
DALLASTOWN, PENNSYLVANIA 17313  
TELEPHONE: 717-741-3861 FAX: 717-741-5009

DATE:	03/30/09
DRAWN BY:	M.J.L.
CHK. BY:	
NO.	YT 02500-4

## SECTION 02525

### CEMENT CONCRETE CURB & SIDEWALK

#### PART 1 - GENERAL

##### 1.01 DESCRIPTION

A. The work of this section includes, but is not limited to:

1. Subgrade preparation
2. Construction of cement concrete curb and sidewalk
3. Construction of handicap ramps

B. Applicable Standard Details:

- YT 02525-1 Vertical Concrete Curb Details
- YT 02525-2 Slant Concrete Curb Details
- YT 02525-3 Concrete Sidewalk Adjacent to Curb Details
- YT 02525-4 Concrete Sidewalk with Grass Strip Details
- YT 02525-5 Handicap Ramp Details (no grass strip)
- YT 02525-6 Handicap Ramp Details (with grass strip)

##### 1.02 QUALITY ASSURANCE

A. Reference Standards:

1. Pennsylvania Department of Transportation (PennDOT), latest revision:

- Publication 408, Specifications
- Publication 213, Temporary Traffic Control Guidelines

2. American Society for Testing and Materials (ASTM):

- A185 Standard Specification for Welded Steel Wire Fabric for Concrete Reinforcement
- A615 Standard Specification for Deformed and Plain Billet-Steel Bars for Concrete Reinforcement
- C94 Specification for Ready-Mixed Concrete
- C143 Test Method for Slump of Hydraulic Cement Concrete
- C231 Test Method for Air Content of Freshly Mixed Concrete by the Pressure Method
- C309 Specification for Liquid Membrane-Forming Compounds for Curing Concrete
- D994 Specification for Preformed Expansion Joint Filler for Concrete (Bituminous Type)
- E329 Specification for Agencies Engaged in the Testing and/or Inspection of Materials used in Construction

3. SALDO Article 5



B. Inspections:

1. Inspection by the Municipality will at a minimum be made of the subgrade, formwork, and any steel prior to placement of the concrete.

1.03 JOB CONDITIONS

A. Control of traffic:

1. Take measures to control traffic during all operations. Do not allow traffic on newly placed concrete until adequate strength has been attained.
2. Employ traffic control measures in accordance with Publication 213, Temporary Traffic Control Guidelines.

B. Coordination with utilities:

1. Coordinate all necessary adjustments of existing utilities to accommodate this work.
2. Provide access to the site for utility work.

PART 2 PRODUCTS

2.01 CONCRETE

- A. Portland cement concrete shall be air-entrained and have a minimum 28 day compressive strength shall be a minimum of 3,500 psi.

B. Cement Concrete criteria for curbs and sidewalks:

Slump:	1" minimum, 4" maximum
Air Content:	4.5% minimum, 7.5% maximum
Temperature:	60EF minimum, 100EF maximum

- C. For slip formed curb, same as above except with a maximum slump of 1-1/2".

- D. For replacement of curb and sidewalk at existing driveways, use air-entrained, PennDOT Class HES (High Early Strength).

2.02 FORMS

A. General requirements:

1. Forms shall be coated with a form release agent just prior to placement of concrete.

B. Straight curbing (or radius greater than 40 feet):

1. Approved metal forms.
2. Wood forms, not less than 2 inch nominal thickness, planed on finish side.

C. Radius curbing:

1. Approved metal forms.
2. Fabricated plywood or hardboard forms.

D. Curbing repairs (less than 10 feet):

1. Approved metal forms.
2. Adjust to match existing conditions (vertical 6" x 8" x xx" or rolled 24" x 10¾").

E. Machine-placed curbing:

1. Straight or radius curbing may be placed with a self-propelled machine approved by the Municipality.

2.03 REINFORCEMENT

- A. Welded Wire Fabric - ASTM A185. Size and spacing as shown on Standard Details.
- B. Reinforcing Bars - ASTM A615, Grade 60 billet steel. Size and spacing as shown on Standard Details.

2.04 JOINT MATERIAL

- A. Joint Filler - Premolded expansion joint material shall be fiber joint filler conforming to ASTM D994. or ASTM D1751.
- B. Joint Sealant - as recommended by joint filler manufacturer.

2.05 FORM COATING MATERIALS

- A. Form release agents shall be non-staining, liquid chemical coatings free of kerosene, oil and wax which effectively prevent absorption of moisture into the forms and bonding of the concrete to the forms.

2.06 CONCRETE CURING COMPOUNDS

- A. Curing compounds shall be clear, non-staining liquid coatings containing no oil or wax and conforming to ASTM C309, such as Safe-Cure, Sealtight 1100, Klear Seal R-75 or Enviocure Clear 500, or similar material.

PART 3 EXECUTION

3.01 CURB CONSTRUCTION

- A. Excavate to required depth, remove and dispose of material, including existing curbs, and compact the subgrade material to a firm, even surface. Curb types as follows:
  1. 7" x 8" x 20" vertical curb (new construction)
  2. 7" x 8" x 18" vertical curb (curb replacement)
  3. Other types only if approved in advance by Municipality

- B. Saw cut existing pavement a minimum of 12" from face of new curb. Exposed edges of existing work shall be smooth and square.
- C. Forms shall be placed as appropriate to the type of curbing on 2 sides (front and back). Forms shall be securely braced to limit deflection during placement of concrete.
- D. Provide openings through curb for drainage pipes. Install one, 2'-0" long, #4 reinforcing bar in the middle of curb centered above the pipe.
- E. Form or saw contraction joints 3/16" wide and 2" deep at 10-foot maximum intervals on 2 sides (front and top). Saw as soon as possible after the concrete has set sufficiently to preclude raveling during the sawing and before any shrinkage cracking occurs in the concrete, but in no case later than 24 hours following completion of the curb placement.
- F. Provide ½" expansion joints at 100-foot intervals, at the end of each pour, and at the beginning and end of all radii. Place ½" expansion joint material to separate curb from adjacent sidewalks, poles, hydrants, walls and other permanent structures, except place 1" thick expansion joint material at storm inlets.
- G. Place 2 - #4 dowels, 24 inches long at the end of each pour, as shown on Standard Detail YT-2525-1. Do not dowel into inlet tops.
- H. The last three feet of curb shall be tapered to a 1-1/2" reveal with expansion joint at the beginning of taper.
- I. Finish top surface. Provide depressions for drainage, driveways, and ramps for the handicapped as directed by the Municipality. Tool all exposed edges to the specified radius.
- J. Do not remove forms until concrete has set. Begin proper curing immediately after placement.
- K. For slip formed curb, uniformly feed the concrete to the machine so the concrete maintains the shape of the section, without slumping after extrusion. Voids or honeycomb on the surface of the finished curb will not be allowed. Immediately after extrusion, perform any additional surface finishing required.

### 3.02 SIDEWALK CONSTRUCTION

- A. Excavate to required depth and width, remove and dispose of material, including any existing sidewalks, and compact the subgrade material to a firm, even surface.
- B. Exposed edges of existing work shall be smooth and square.
- C. Construct ramps for handicapped persons at all street crossings (as required by ADA regulations) as directed by the Municipality. Handicap ramps shall be 6" thick concrete.
- D. Sidewalks across sanitary sewer or storm sewer easements shall be 8" thick.
- E. Spread AASHTO No. 57 aggregate and compact to the thickness shown on the Standard Details.

- F. Score contraction joints at 5-foot intervals to sufficient depth to insure cracking at the joint. Do not saw cut the contraction joints without prior approval from the Municipality. Also score sidewalks over each drainage pipe placed underneath.
- G. Provide 1/4" expansion joint at 30-foot intervals and at the end of each pour. Place 1/2" expansion joint material at adjacent curb, poles, hydrants, walls, and other permanent structures.
- H. Apply light broom finish immediately after float finish.
- I. Provide depressions for driveways, downspouts, and drainage as directed by the Municipality or shown on the drawings. Wherever possible, roof leaders shall be placed under the sidewalks in lieu of depressions.
- J. Begin proper curing immediately following placement.
- K. Monolithic sidewalk and curb will not be allowed at a radius handicap ramp.

### 3.03 BACKFILLING AND RESTORATION

- A. Temporary backfill at curbs shall consist of select granular material front and back, to within 8" of top of curb.
- B. Restore adjacent areas in kind.

END OF SECTION

K:\094990003\dwg\DETAILS - MAY 2015\DETAILS (original in autocadd)\YT02525-1REV.dwg, 8/10/2015 8:00:48 AM

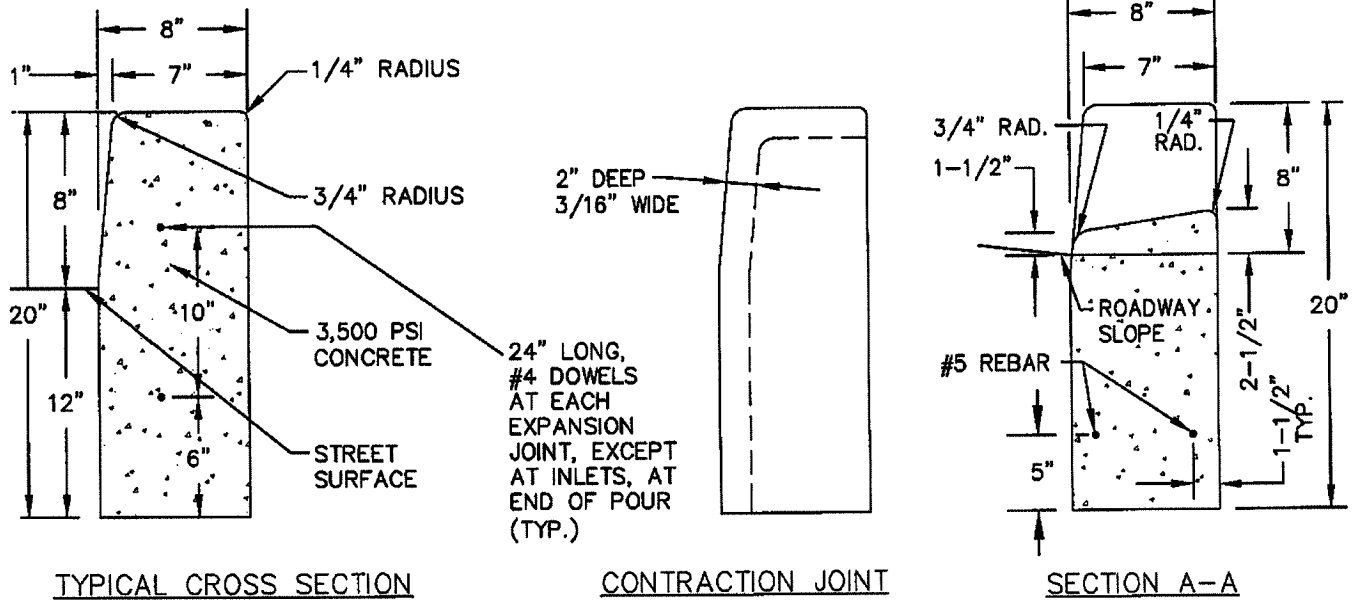

NOTE: CONSTRUCT 18" CURBS FOR CURB REPLACEMENT.

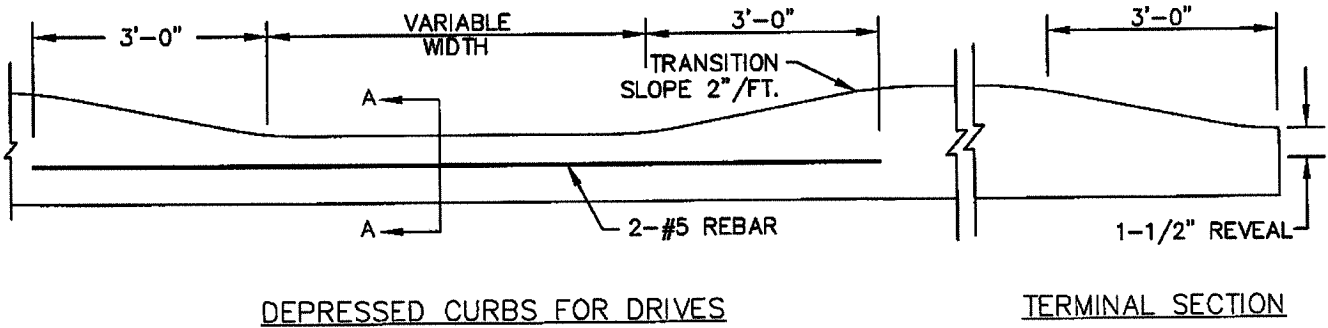

REVISED 5/20/2015  
NOT TO SCALE

YORK TOWNSHIP CONSTRUCTION & MATERIALS SPECIFICATIONS

YORK TOWNSHIP BOARD OF COMMISSIONERS  
190 OAK ROAD  
DALLASTOWN, PENNSYLVANIA 17313  
TELEPHONE: 717-741-3861 FAX: 717-741-5009

**VERTICAL CONCRETE  
CURB DETAILS**

DATE: 10/17/2007  
DRAWN BY: MJL  
CHK. BY:  
NO. YT-02525-1REV

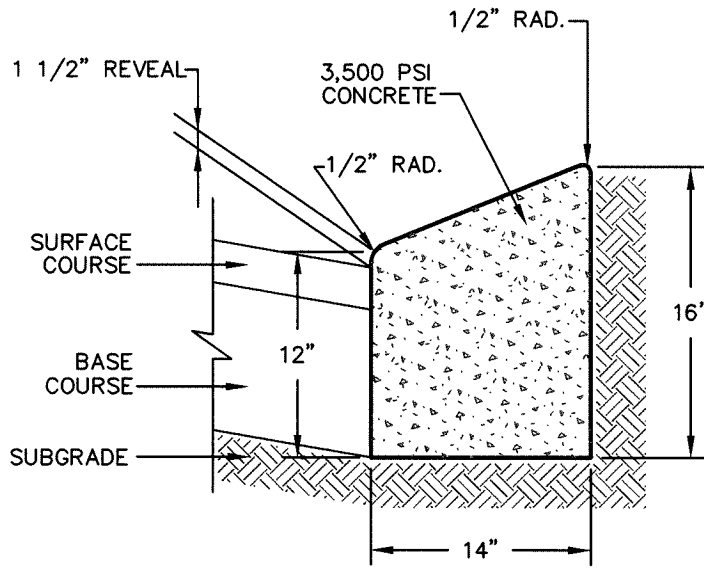

TYPICAL CROSS SECTION

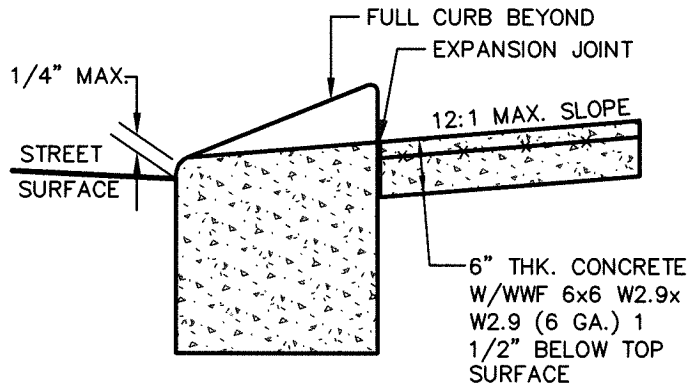

CROSS SECTION AT HANDICAP RAMPS

NOTE: NOT TO SCALE:

**YORK TOWNSHIP CONSTRUCTION & MATERIALS SPECIFICATIONS**

**YORK TOWNSHIP BOARD OF COMMISSIONERS**  
**190 OAK ROAD**  
**DALLASTOWN, PENNSYLVANIA 17313**  
**TELEPHONE: 717-741-3861 FAX: 717-741-5009**

**SLANT CONCRETE**  
**CURB DETAILS**

DATE:	03/30/09
DRAWN BY:	MJL
CHK. BY:	
NO.	YT-02525-2

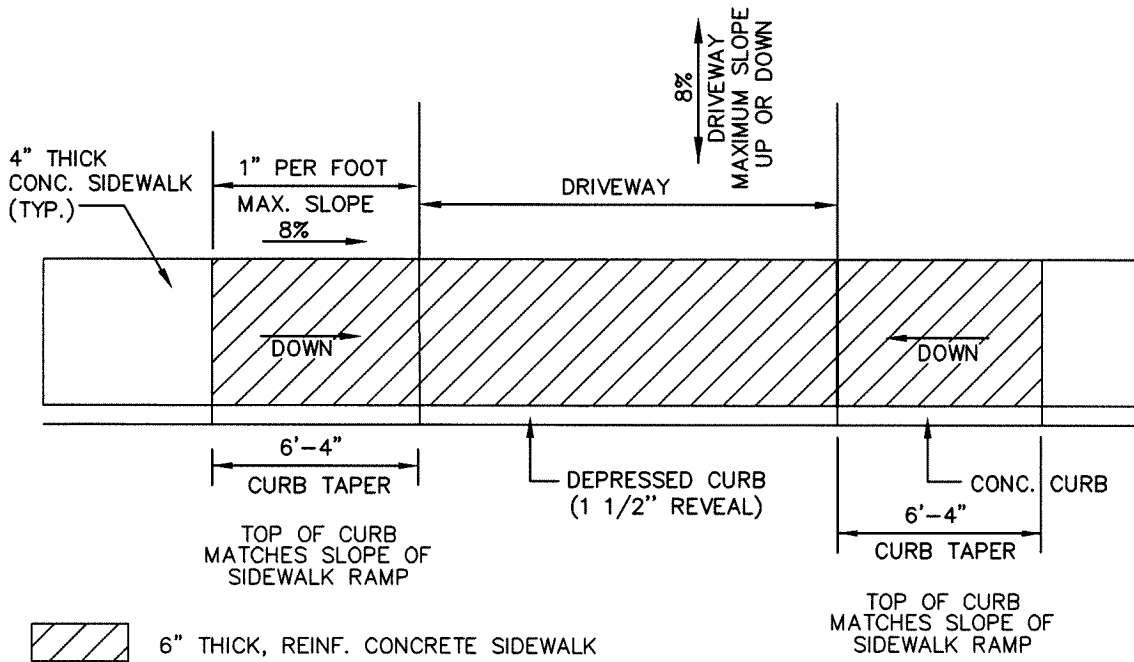

PLAN OF 4' SIDEWALK ADJACENT TO CURB

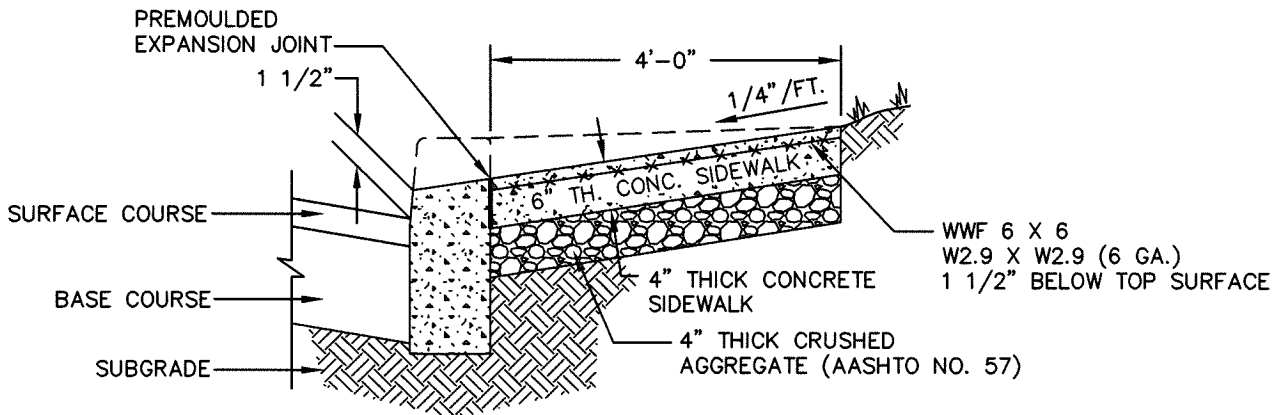

TYPICAL SECTION THROUGH CONCRETE CURB & SIDEWALK AT DRIVEWAY DEPRESSION

NOTE: NOT TO SCALE:

YORK TOWNSHIP CONSTRUCTION & MATERIALS SPECIFICATIONS

YORK TOWNSHIP BOARD OF COMMISSIONERS  
190 OAK ROAD  
DALLASTOWN, PENNSYLVANIA 17313  
TELEPHONE: 717-741-3861 FAX: 717-741-5009

**CONCRETE SIDEWALK  
ADJACENT TO CURB  
DETAILS**

DATE: 03/03/09

DRAWN BY: MJL

CHK. BY:

NO. YT 02525-3

 6" THICK, REINF. CONCRETE SIDEWALK

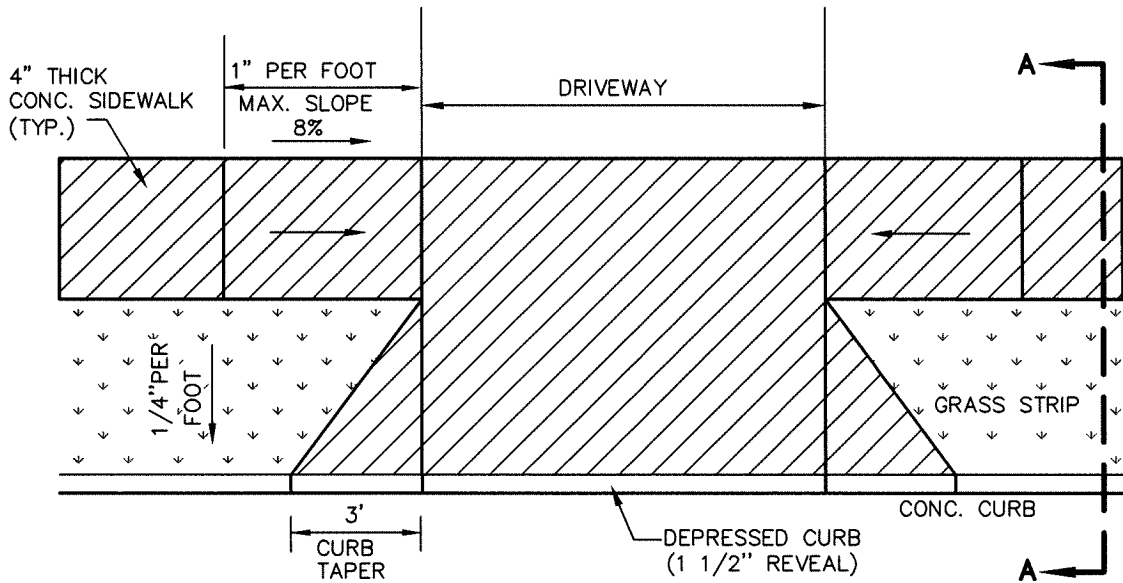

**PLAN**

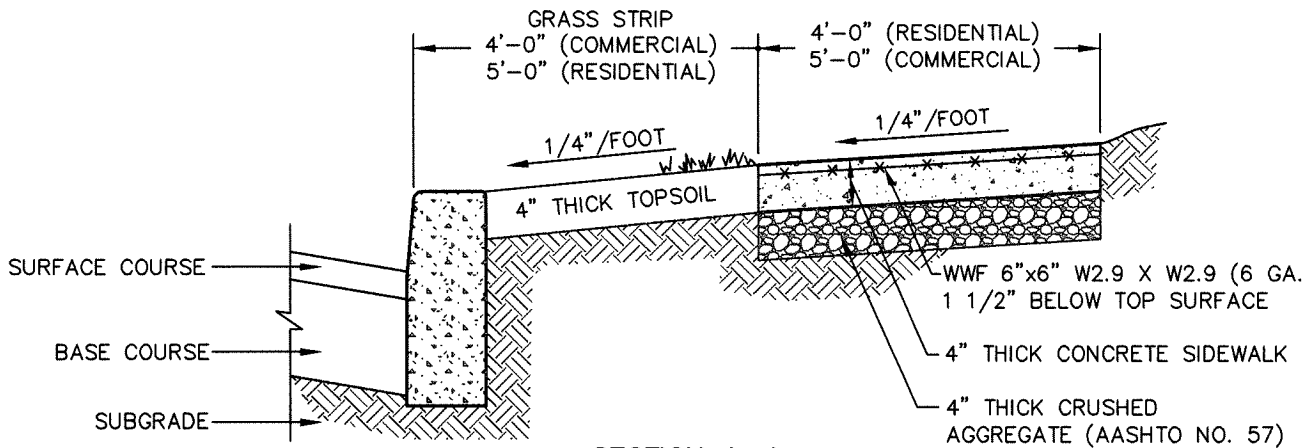

**SECTION A-A**

SEE SECTION 02500 FOR PAVING SPECIFICATIONS

SEE DETAIL YT 02525-3 FOR DETAILS AT DRIVEWAY AND DEPRESSED CURB.

NOTE: NOT TO SCALE

**YORK TOWNSHIP CONSTRUCTION & MATERIALS SPECIFICATIONS**

**YORK TOWNSHIP BOARD OF COMMISSIONERS**  
 190 OAK ROAD  
 DALLASTOWN, PENNSYLVANIA 17313  
 TELEPHONE: 717-741-3861 FAX: 717-741-5009

**CONCRETE SIDEWALK  
 WITH GRASS STRIP  
 DETAILS**

DATE:	03/30/09
DRAWN BY:	MJL
CHK. BY:	
NO.	YT 02525-4



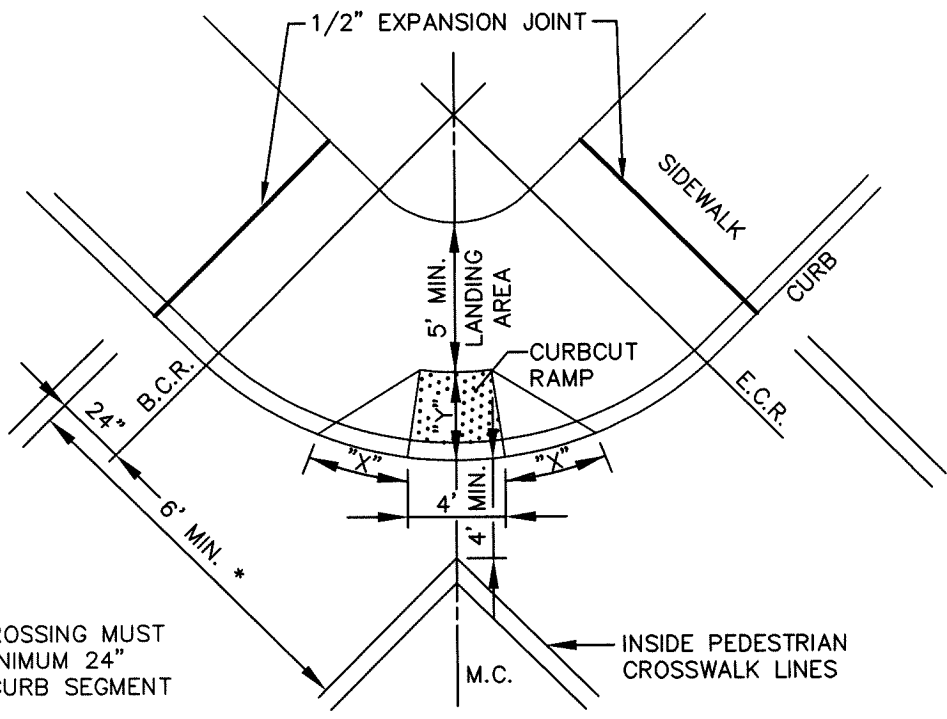
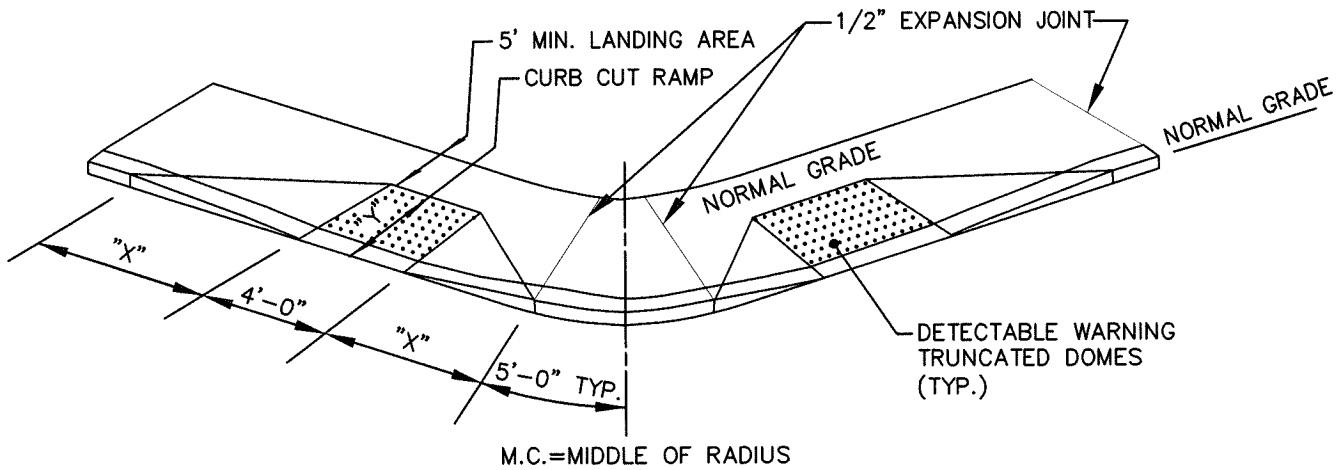

\* MARKED CROSSING MUST INCLUDE MINIMUM 24" STRAIGHT CURB SEGMENT

"X" - LENGTH NEEDED TO MAINTAIN A MAXIMUM 12:1 SLOPE ALONG THE FACE OF THE CURB.  
 "Y" - LENGTH NEEDED TO MAINTAIN A MAXIMUM 12:1 SLOPE FROM THE CURB LINE TO THE TOP OF THE RAMP.

REFER TO PENNDOT RC 67M FOR MORE INFORMATION

NOTE: NOT TO SCALE:

**YORK TOWNSHIP CONSTRUCTION & MATERIALS SPECIFICATIONS**

**YORK TOWNSHIP BOARD OF COMMISSIONERS**  
 190 OAK ROAD  
 DALLASTOWN, PENNSYLVANIA 17313  
 TELEPHONE: 717-741-3861 FAX: 717-741-5009

**HANDICAP RAMP  
 DETAILS  
 (NO GRASS STRIP)**

DATE:	03/30/09
DRAWN BY:	MJL
CHK. BY:	
NO.	YT-02525-5

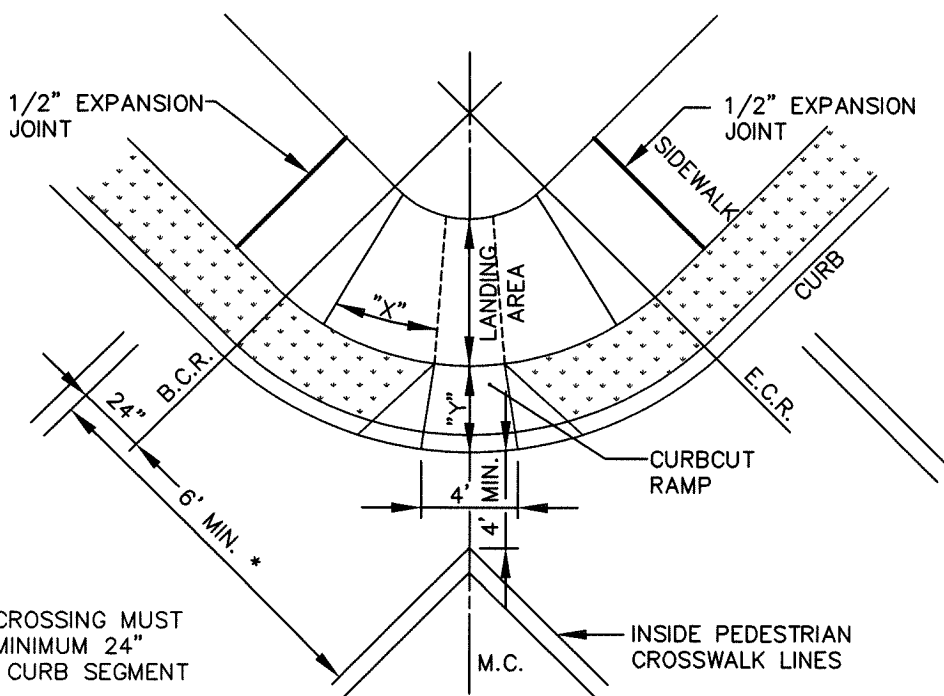
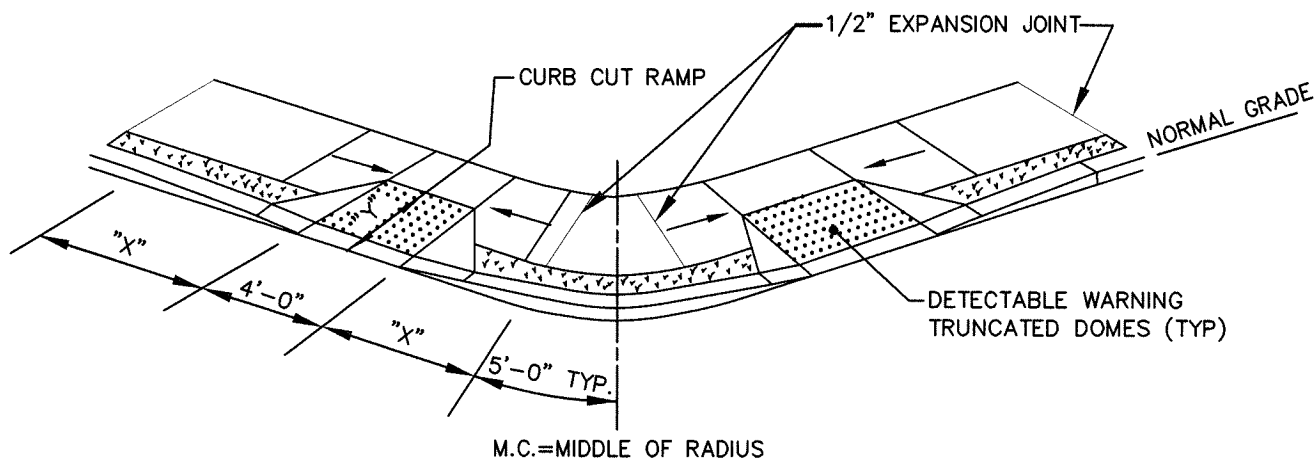

\* MARKED CROSSING MUST INCLUDE MINIMUM 24" STRAIGHT CURB SEGMENT

"X" - LENGTH NEEDED TO MAINTAIN A MAXIMUM 12:1 SLOPE ALONG THE FACE OF THE CURB.

"Y" - LENGTH NEEDED TO MAINTAIN A MAXIMUM 12:1 SLOPE FROM THE CURB LINE TO THE TOP OF THE RAMP.

REFER TO PENNDOT RC 67M FOR MORE INFORMATION

NOTE: NOT TO SCALE:

## YORK TOWNSHIP CONSTRUCTION & MATERIALS SPECIFICATIONS

**YORK TOWNSHIP BOARD OF COMMISSIONERS**  
**190 OAK ROAD**  
**DALLASTOWN, PENNSYLVANIA 17313**  
**TELEPHONE: 717-741-3861 FAX: 717-741-5009**

### HANDICAP RAMP DETAIL (WITH GRASS STRIP)

DATE: 03/30/09

DRAWN BY: MJL

CHK. BY:

NO. YT-02525-6

SECTION 02575

TRENCH PAVING AND RESTORATION

PART 1 GENERAL

1.01 DESCRIPTION

A. The work of this section includes, but is not limited to:

1. Temporary trench paving
2. Permanent trench paving
3. Shoulder restoration
4. Driveway restoration

B. Related work specified elsewhere:

- |  |               |
|--|---------------|
| 1. Trenching, backfilling, and compacting: | Section 02221 |
| 2. Bituminous paving and surfacing:        | Section 02500 |
| 3. Plain and reinforced cement concrete:   | Section 03000 |

C. Definitions: NONE

D. Applicable Standard Details:

- YT 02575-1 Temporary Trench Paving
- YT 02575-2 Permanent Trench Paving

1.02 QUALITY ASSURANCE

A. Reference Standards:

1. Pennsylvania Department of Transportation (PennDOT), latest revision:

- Publication 408, Specifications
- Publication 213, Temporary Traffic Control Guidelines
- Publication 27, Specification for Bituminous Mixtures (Bulletin 27)
- Publication 37, Specification for Bituminous Materials (Bulletin 25)
- Publication RR-459, Occupancy of Highways by Utilities
- York Township Code, Article 1, Chapter 275

2. American Society for Testing and Materials (ASTM):

- D2950 Test Method for Density of Bituminous Concrete in Place by Nuclear Method

3. York Township Code, Article 1, Chapter 275

B. Inspections:

1. Inspection by the Municipality will, at a minimum, be made of the subgrade prior to placement of the base course, and of the base course prior to placement of the binder surface.

### 1.03 SUBMITTALS

#### A. Certificates:

1. Submit certification from bituminous and aggregate suppliers attesting that materials conform to Publication 408. Submit bituminous concrete mix design for approval. Provide PennDOT certifications with each load delivered to the job site.

### 1.04 JOB CONDITIONS

#### A. Control of Traffic:

1. Take measures to control traffic during paving operations. Do not allow traffic on newly paved areas until adequate stability and adhesion have been attained and the material has cooled to 140° F or less.
2. Employ traffic control measures in accordance with Publication 213.

#### B. Protection of Adjacent Areas:

1. Restore existing surface outside the limits of the work that has been damaged by the Contractor's operations to its original condition at the expense of Contractor.

#### C. Concrete Testing: Section 03000.

## PART 2 PRODUCTS

### 2.01 CONCRETE

#### A. As specified in Section 03000.

- #### B. For driveway restoration, use air-entrained, PennDOT Class HES (High Early Strength). (3-day compressive strength of 3,000 psi, 28-day compressive strength of 3,750 psi, as per Section 704 of Pub. 408).

### 2.02 BITUMINOUS MATERIALS AND AGGREGATES

- #### A. All bituminous materials and aggregates used in base course construction, paving, and resurfacing are designated in these specifications by, and shall conform to, the applicable portions of the Publication 408 Specifications. See descriptions in Sections 02230 and 02500.

## PART 3 EXECUTION

### 3.01 TEMPORARY TRENCH PAVING

- #### A. Place temporary paving immediately upon completion of trench backfilling. Unpaved trenches shall not remain unpaved longer than five working days after backfilling, nor over weekends and holidays.
- #### B. Shape and compact subgrade material, then place and compact base course to the required thicknesses shown in Standard Detail YT 02575-1.

- C. Place temporary paving material. Compact to required minimum thickness shown on Standard Details with trench roller having a minimum 300 pounds pressure per inch-width of compaction.
- D. Continuously maintain temporary paving (minimum 60 days).

### 3.02 PERMANENT TRENCH PAVING

- A. For Bituminous Surface Course (Trench) saw cut existing paving in accordance with Publication RR-459. Remove temporary paving material.
- B. Construct permanent base and surface courses to the required compacted thicknesses shown in the Standard Detail YT 02575-2. In State Highways, construct permanent paving in accordance with Highway Occupancy Permit requirements.
- C. Maintain permanent paving throughout the contract maintenance period or for warranty period specified under street cut permit.

### 3.03 BITUMINOUS OVERLAY

- A. See Section 02500.

### 3.04 SHOULDER RESTORATION

- A. Restore shoulders as directed by the Municipality. In State Highways, restore in accordance with Highway Occupancy Permit requirements.

### 3.05 DRIVEWAYS

- A. Trim concrete and bituminous driveway surfaces to remove damaged areas. Saw or cut straight joint lines parallel to the centerline of the trench. Cut offsets at right angles to the trench centerline.
- B. Restore existing concrete driveways with a 6" layer of concrete reinforced with WWF 6 x 6 - W2.9 x W2.9 (6 ga.) wire mesh, placed 2" from top surface. See Section 03000.
- C. Restore existing bituminous driveways in kind; minimum 1½" layer wearing course over 6" layer of granular material (2A stone).
- D. Restore earth driveways with a 6" layer of granular material (2A stone).
- E. Restore stone or gravel driveways in kind; minimum 6" layer of granular material (2A stone).
- F. Restore brick driveways with like bricks placed on a 4" thick wet sand bed. Place bricks in like pattern and spacing.

### 3.06 UNPAVED SURFACES

- A. Restore surfaces to a condition equal to that prior to construction.

B. Restore grassed or landscaped areas in accordance with Sections 02485 and 02901.

END OF SECTION

K:\09499003\dwg\DETAILS - MAY 2015\DETAILS (original in autocadd)\YT02575-1rev.dwg - 8/10/2015 8:01:29 AM

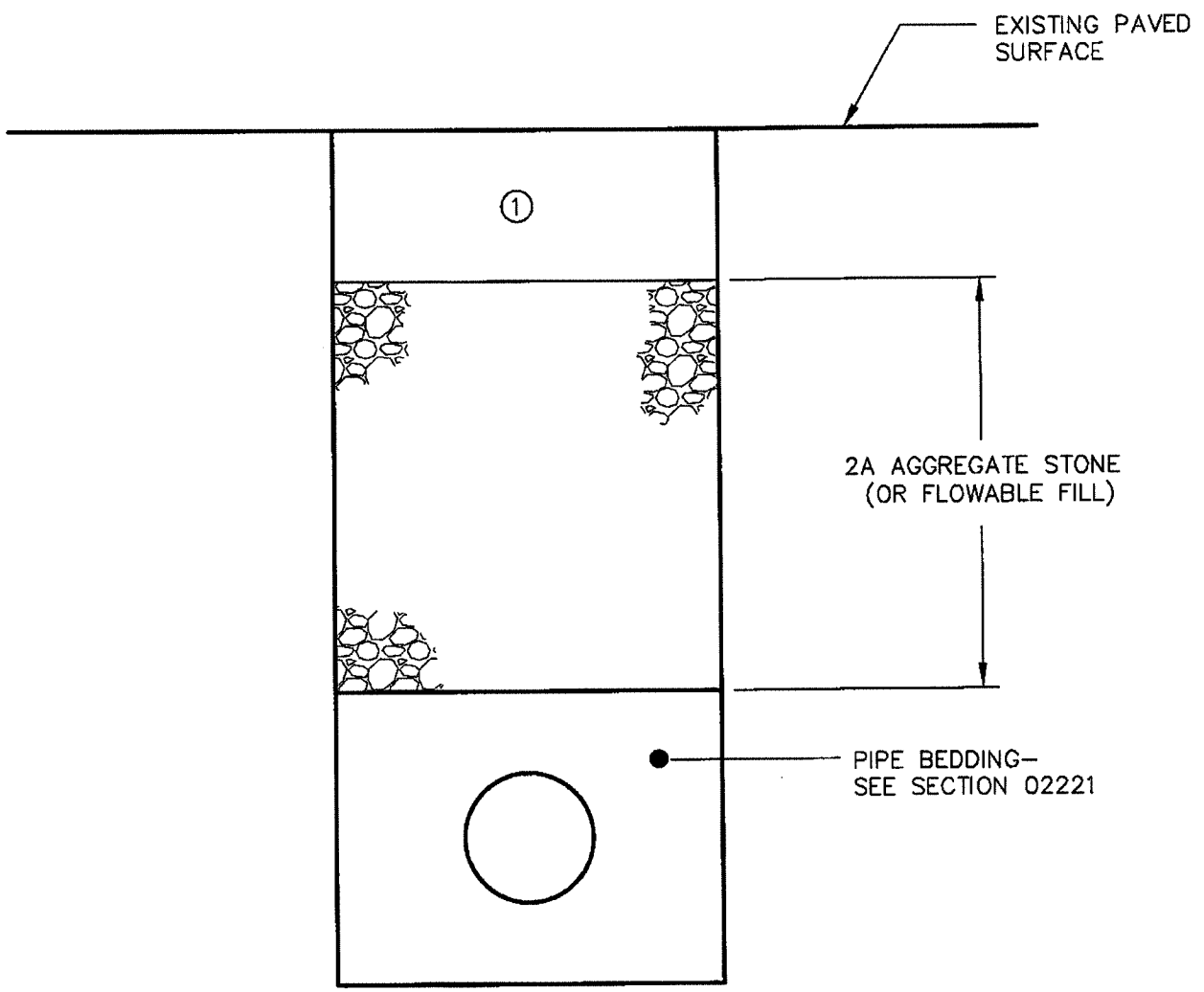

NOTES:

- ① ALL TOWNSHIP STREET CLASSIFICATIONS - 5" OF 19MM SUPERPAVE BINDER
- ② COLD PATCH ACCEPTED IN WINTER MONTHS
- ③ IN STATE ROADS, SEE HIGHWAY OCCUPANCY PERMIT
- ④ MAINTAIN TEMPORARY PAVING UNTIL PERMANENT PAVING IS PLACED (MAX. 60 DAYS)

REVISED 5/20/2015  
NOT TO SCALE

**YORK TOWNSHIP CONSTRUCTION & MATERIALS SPECIFICATIONS**

**YORK TOWNSHIP BOARD OF COMMISSIONERS**  
**190 OAK ROAD**  
**DALLASTOWN, PENNSYLVANIA 17313**  
**TELEPHONE: 717-741-3861 FAX: 717-741-5009**

**TEMPORARY TRENCH  
PAVING DETAIL**

DATE:	03/30/09
DRAWN BY:	MJL
CHK. BY:	
NO.	YT 02575-1REV

K:\094990003\dwg\DETAILS - MAY 2015\DETAILS (original in autocadd)\YT02575-2REV.dwg 8/10/2015 8:02:04 AM

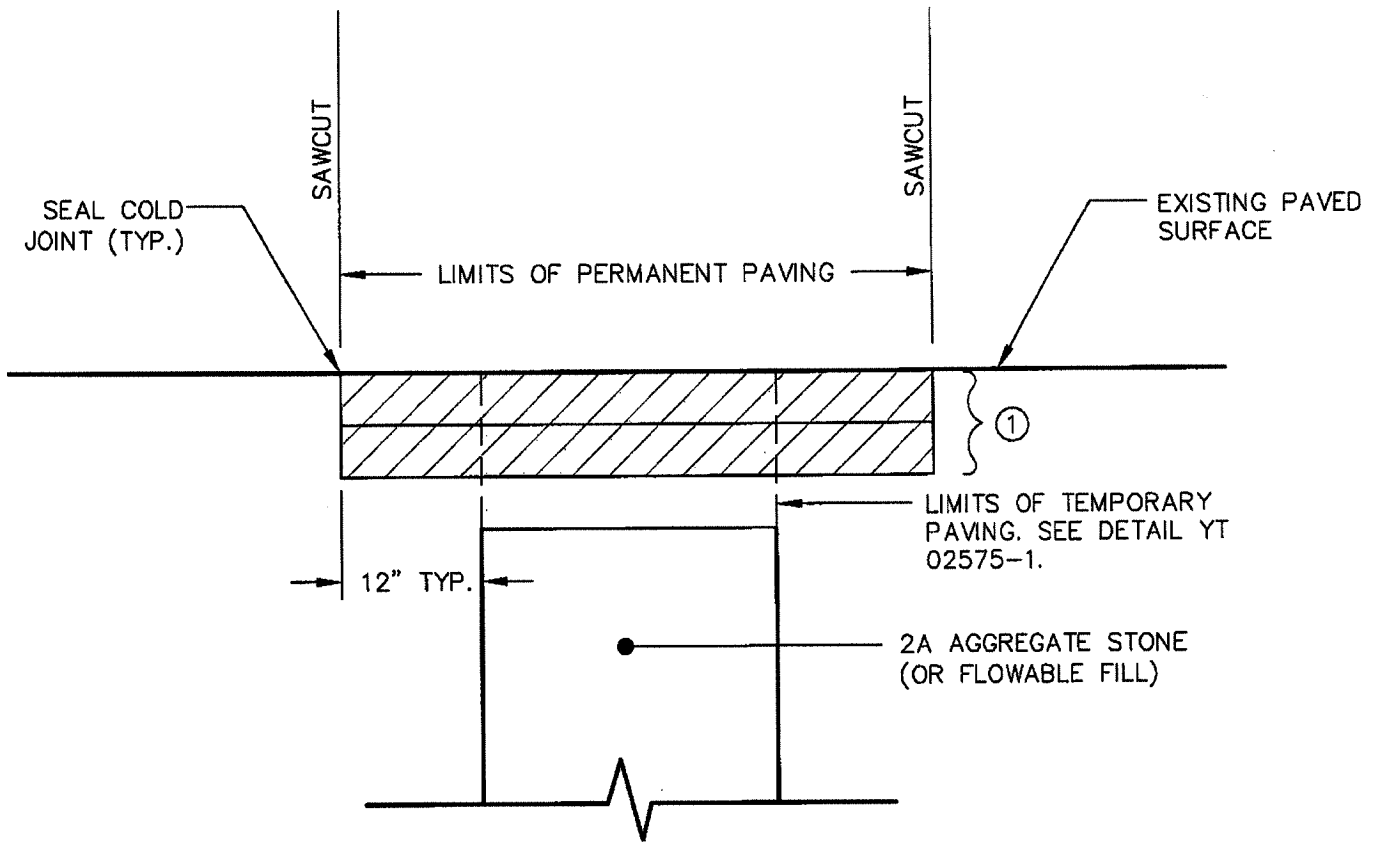

STREET CLASSIFICATION	①
ARTERIAL	3" 25 MM HMA BINDER COURSE SUPERPAVE; 2" 9.5 MM HMA WEARING SUPERPAVE
COLLECTOR	3" 25 MM HMA BINDER COURSE SUPERPAVE; 2" 9.5 MM HMA WEARING SUPERPAVE
* LOCAL AND CUL-DE-SAC	3" 25 MM HMA BINDER COURSE SUPERPAVE; 2" 9.5 MM HMA WEARING SUPERPAVE
STATE ROADS	SEE PERMIT

\* OR AS DIRECTED BY YORK TOWNSHIP

① REMOVE ALL TEMPORARY MATERIAL

REVISED 5/20/2015  
NOT TO SCALE

## YORK TOWNSHIP CONSTRUCTION & MATERIALS SPECIFICATIONS

**YORK TOWNSHIP BOARD OF COMMISSIONERS**  
190 OAK ROAD  
DALLASTOWN, PENNSYLVANIA 17313  
TELEPHONE: 717-741-3861 FAX: 717-741-5009

### PERMANENT TRENCH PAVING DETAIL

DATE: 03/30/09  
DRAWN BY: MJL  
CHK. BY:  
NO. YT 02575-2REV



SECTION 02581

CONDUIT FOR UNDERGROUND UTILITIES

PART 1 GENERAL

1.01 DESCRIPTION

A. The work of this section includes, but is not limited to, installation of conduits for:

1. Natural gas transmission
2. Underground electrical power transmission
3. Underground telephone and cable TV

B. Related Work Specified Elsewhere:

1. Trenching, backfilling and compacting: Section 02221

C. Definitions: NONE

D. Applicable Standard Details: NONE

1.02 QUALITY ASSURANCE

A. American Society for Testing and Materials (ASTM):

- D1785 Specifications for Poly (Vinyl Chloride)(PVC) Plastic Pipe, Schedule 40, 80, and 120
- D2321 Recommended Practice for Underground Installation of Flexible Thermoplastic Sewer Pipe
- D2564 Specifications for Solvent Cements for Poly (Vinyl Chloride)(PVC) Plastic Pipe and Fittings
- D2855 Recommended Practice for Making Solvent-Cemented Joints with Poly (Vinyl Chloride)(PVC) Plastic Pipe and Fittings
- D2729 Specifications for Poly (Vinyl Chloride)(PVC) Sewer Pipe and Fittings

B. Materials contaminated with gasoline, lubricating oil, liquid or gaseous fuel, aromatic compounds, paint solvents, paint thinner, or acid solder will be rejected.

1.03 SUBMITTALS: Section not utilized

1.04 JOB CONDITIONS: See Section 02221.

## 1.05 PRODUCT DELIVERY, STORAGE AND HANDLING

### A. Delivery and Handling:

1. During loading, transporting and unloading, exercise care to prevent damage to materials.
2. Do not drop pipe or fittings. Avoid shock or damage at all times.
3. Take measures to prevent damage to the exterior surface or internal lining of the pipe.

### B. Storage:

1. Do not stack pipe higher than recommended by the pipe manufacturer.
2. Store PVC pipe and fittings in a cool, dry location out of direct sunlight and not in contact with petroleum products.

## PART 2 - PRODUCTS

### 2.01 POLY (VINYL CHLORIDE) (PVC) UTILITY CONDUIT

#### A. Natural Gas:

1. Main line conduits - three inch (3") diameter and larger shall meet the requirements of ASTM D2729. Joints shall be solvent cement.
2. Service line conduits - two and one-half inch (2½") diameter and smaller shall meet the requirements of ASTM D1785 (Schedule 40). Joints shall be solvent cement.

#### B. Telephone, Electric and Cable TV:

1. Main line conduits - three inch (3") diameter and larger shall meet the requirements of ASTM D2729. Joints shall be solvent cement.
2. Service lines - one inch (1") diameter minimum. No direct buried wiring under roads, paving and sidewalks.

### 2.02 WARNING TAPE

- #### A. Metallic warning tape, six inch (6") minimum width, printed with "CAUTION BURIED UTILITY LINE BELOW" or similar. Tape may be provided by utility company or furnished by the installing contractor and approved by utility. Materials shall meet requirements of U.S. DOT, Office of Public Safety.

### 2.03 AS-BUILT DRAWINGS

- #### A. All underground utilities shall be documented with as-built drawings provided to York Township prior to street dedication.

## PART 3 – EXECUTION

### 3.01 EXCAVATION

#### A. Depth of Excavation

1. Natural Gas Line (per Gas Company Specifications):

- a. Excavate main line trenches to a minimum depth of 36". Grade for the invert of the conduit plus that excavation necessary for placement of bedding material. During Street construction, prior to installation of the stone base course, conduits shall be installed at all proposed crossings. Conduits shall extend a minimum of two feet (2') beyond the curb line where curbs are proposed or a minimum of five feet (5') beyond the paving where no curbs are proposed to be installed.
- b. Excavation for service lines shall be as nearly perpendicular to the street centerline as possible and shall be a minimum of twenty-four inches (24") deep plus that excavation necessary for placement of bedding material. A minimum of two (2) service line conduits shall be placed for each lot which will require a street crossing, prior to installation of the stone base course. Location of the service line conduits shall be coordinated with the local gas supplier. With written authorization from the gas supplier, the number of conduits may be reduced to one (1). In any event, no open cut trenching for installation of gas services will be allowed after installation of the stone base course.

2. Electric Conduits:

- a. Excavate main line trenches to a minimum depth of twenty-four inches (24") plus that excavation necessary for placement of bedding material. During street construction and prior to installation of the stone base course, conduits shall be installed at all proposed crossings. Conduits shall extend a minimum of two feet (2') beyond the curb line where curbs are proposed or a minimum of five feet (5') beyond the paving where no curbs are proposed to be installed.

3. Telephone and Cable TV:

- a. Excavate main line trenches to a minimum depth of twenty-four inches (24") plus that excavation necessary for placement of pipe bedding material. During street construction and prior to installation of the stone base course, conduits shall be installed at all proposed crossings. Conduit shall extend a minimum of two feet (2') beyond the curb line where curbs are proposed or a minimum of five feet (5') beyond the paving where no curbs are proposed to be installed.

- B. Where unsuitable bearing material is encountered in the trench bottom, continue excavation until the unsuitable material is removed, solid bearing is obtained or can be established, or concrete cradle can be placed. If no concrete cradle is to be installed, refill the trench bottom to required conduit grade, minus six inches (6") for bedding, with Penn DOT 2A crushed aggregate.

- C. Width of Excavation:
1. Excavate main line and service trenches to a maximum width of twenty-four inches (24").
- D. Lay conduit to a true uniform line with a barrel of the conduit resting solidly in bedding material throughout its length. Excavate recesses in bedding material to accommodate joints. Do not subject the conduit to a blow or shock to achieve solid bearing or grade.
- E. Lay section of conduit in such a manner as to form a closed concentric joint with the adjoining section and to avoid offsets in the conduit.
- F. Clean and inspect each section of the conduit before joining. Assemble to provide tight, flexible joints that permit movement caused by expansion, contraction, and ground movement. If unusual joining resistance is encountered or if the conduit cannot be fully inserted into the bell, disassemble joint, inspect for damage, reclean joint components, and reassemble joint.
- G. Assemble joints in accordance with recommendations of the manufacturer.
1. Camfer and deburr conduit. Clean socket and plain end. Measure and mark the socket depth on the outside of the conduit.
  2. Apply primer to inside socket surface using a scrubbing motion to ensure penetration. Repeated applications may be necessary. Soften surface of male end of conduit to depth of fitting socket by applying a liberal brush coat of primer. Do not pour primer on. Assure entire surface is well softened.
  3. Repeat application of primer to inside socket surface, then apply cement to conduit while surfaces are still wet with primer. Apply cement uniformly taking care to keep excess cement out of socket.
  4. Immediately after applying the last coat of cement to the conduit, and while both the inside socket surface and outside conduit surface are soft and wet, forcefully seat the conduit into the socket. Turn the conduit  $\frac{1}{4}$  turn during assembly to distribute the cement evenly. Assembly should be completed within twenty (20) seconds after the last application of cement. Insert conduit with a steady, even motion. Do not use hammer blows.
  5. Hold joint in place until cement has set. Wipe excess cement from the conduit.
- H. Place sufficient compacted bedding and backfill on each section of conduit, as it is laid, to hold firmly in place.
- I. Keep trenches and excavations free from water during construction.
- J. When work is not in progress, at the end of each day, and at the end of each conduit run, securely plug open ends of conduit to prevent trench water, earth, and other substances from entering the conduit.

3.02 CONDUIT BEDDING AND BACKFILL

- A. All conduits must be surrounded with a minimum of six inches (6") of stone dust (AASHTO#10) on top, bottom and each side.
- B. For specific higher voltage lines, place 6" concrete encasement as directed by the utility company. Refer to Met Ed Specifications.

3.03 DETECTABLE WARNING TAPE FOR ELECTRIC AND NATURAL GAS CONDUITS

- A. The warning tape shall be installed twelve inches (12") below the finished ground or street surface for entire length of the conduit. Maintain sufficient separation between tape and the conduit.

END OF SECTION

SECTION 02610

SANITARY SEWER PIPE

PART 1 GENERAL

- 1.01 The work of this section includes installing, repairing and testing of all sanitary sewers.
- 1.02 All public sanitary sewers in the Municipality are owned and maintained by the Municipality.

PART 2 PRODUCTS

- 2.01 All materials shall be in accordance with the requirements of the York Township Water & Sewer Authority.

PART 3 EXECUTION

- 3.01 All work shall be performed in accordance with the requirements of the York Township Water & Sewer Authority.
- 3.02 All trench excavation, backfill, bedding, and pavement restoration work shall comply with these specifications.

END OF SECTION

SECTION 02615

WATER MAINS

PART 1 GENERAL

- 1.01 The work of this section includes the installing, repairing and testing of water mains.
- 1.02 All public water mains in the Municipality are owned and maintained by The York Water Company, the Dallastown-Yoe Water Authority, or the Red Lion Municipal Authority.

PART 2 PRODUCTS

- 2.01 All materials shall be in accordance with the requirements of the appropriate water company.

PART 3 EXECUTION

- 3.01 All work shall be performed in accordance with the requirements of the appropriate water company.
- 3.02 All trench excavation and pavement restoration shall comply with these specifications.

END OF SECTION

SECTION 02618

STORM DRAIN PIPE

PART 1 GENERAL

1.01 DESCRIPTION

A. The work of this section includes, but is not limited to:

1. Storm sewer pipelines
2. Pavement base drains and subdrains

B. Related work specified elsewhere:

- |   |               |
|---|---------------|
| 1. Boring and jacking:                          | Section 02150 |
| 2. Trenching, backfilling and compacting:       | Section 02221 |
| 3. Soil erosion and sediment pollution control: | Section 02270 |
| 4. Finish grading, seeding and sodding:         | Section 02485 |
| 5. Trench paving and restoration:               | Section 02575 |
| 6. Inlets, manholes and endwalls:               | Section 02630 |
| 7. Cement concrete for utility construction:    | Section 03050 |

C. Definitions:

1. Polyethylene pipe Type C - full circular cross-section with corrugated surface both inside and outside. (For underdrain only).
2. Polyethylene pipe Type S - full circular cross-section with outer corrugated pipe wall and smooth inner wall.

D. Applicable Standard Details: NONE

1.02 QUALITY ASSURANCE

A. Reference Standards:

1. Pennsylvania Department of Transportation (PennDOT), latest revision:

Publication 408, Specifications  
Publication 72M, Standards for Roadway Construction

2. American Society for Testing and Materials (ASTM):

- |       |   |
|-------|---|
| C76   | Specification for Reinforced Concrete Culvert, Storm Drain, and Sewer Pipe                                  |
| C507  | Specification for Reinforced Concrete Elliptical Culvert, Storm Drain, and Sewer Pipe                       |
| D2241 | Specification for Poly(Vinyl Chloride)(PVC) Pressure Rated Pipe (SDR series)                                |
| D2321 | Practice for Underground Installation of Thermoplastic Pipe for Sewers and other Gravity-Flow Applications. |
| F405  | Specification for Corrugated Polyethylene (PE) Tubing and Fittings  |



F667 Specification for Large Diameter Corrugated Polyethylene Pipe and Fittings

3. American Association of State Highway Transportation Officials (AASHTO):

- M36 Metallic (zinc or aluminum) coated corrugated steel culverts and underdrains
- M246 Precoated galvanized steel sheet for culverts and underdrains
- M252 Corrugated Polyethylene Drainage Tubing
- M278 Class PS50 Polyvinyl Chloride (PVC) Pipe
- M294 Corrugated Polyethylene Pipe (12" to 48" Diameter)
- MP7 Corrugated Polyethylene Pipe (54" to 60" Diameter)

1.03 SUBMITTALS

A. Certificates:

1. Submit two copies of manufacturer's certification attesting that the pipe, fittings, and joints meet or exceed specification requirements.

B. Manufacturer's Literature:

1. Submit two copies of the manufacturer's recommendations on installation, handling, and storage of materials.

1.04 JOB CONDITIONS: Section not utilized.

1.05 PRODUCT DELIVERY, STORAGE, AND HANDLING

- A. During loading, transporting, and unloading, exercise care to prevent damage to materials.
- B. Do not drop pipe or fittings. Avoid shock or damage at all times.
- C. Do not place materials on private property without written permission from the property owner.

PART 2 PRODUCTS

2.01 CORRUGATED POLYETHYLENE PIPE

A. Tubing and Fittings - 3" to 6"

1. AASHTO M252
2. ASTM F405

B. Pipe and Fittings - 12" to 60" (18" minimum diameter in public rights-of-way)

1. Integrally formed smooth interior (Type S).
2. AASHTO M294 and MP6-95
3. ASTM F667

C. Pavement Base Drains - 4", 6"

- A. AASHTO M304

2.02 REINFORCED CONCRETE PIPE (18" minimum diameter in public rights-of-way)

A. Pipe and Fittings:

1. ASTM C76, Minimum Class II

B. Joints:

1. Tongue and groove or bell and spigot.

2.03 ELLIPTICAL REINFORCED CONCRETE PIPE

A. Pipe:

1. ASTM C507, Minimum Class HE-A or VE-II.

2.04 POLY (VINYL CHLORIDE) PIPE 3" TO 6"

A. Pipe and Fittings

1. AASHTO M278
2. ASTM D3034

2.05 PIPE CULVERT END SECTIONS

1. Concrete - Comply with the requirements of Publication 72M.
2. Polyethylene end sections shall have smooth interior and be anchored at the flared end.

PART 3 EXECUTION

3.01 PREPARATION

- A. Perform trench excavation and associated work as specified in Section 02221.
- B. Provide AASHTO No. 57 pipe bedding as specified in Section 02221. Place aggregate so that the pipe can be laid to the required tolerances.

### 3.02 LAYING PIPE IN TRENCHES

- A. Give ample notice to the Municipality in advance of pipe laying operations, minimum twenty-four hours.
- B. Lower pipe into trench using handling equipment designed for the purpose to assure safety of personnel and to avoid damage to pipe. Do not drop pipe.
- C. Lay pipe proceeding upgrade with the bell or groove pointing upstream.
- D. Lay pipe to a true uniform line with the barrel of the pipe resting solidly in bedding material throughout its length. Excavate recesses in bedding material to accommodate joints, fittings and appurtenances. Do not subject pipe to a blow or shock to achieve solid bearing or grade.
- E. Lay each section of pipe in such a manner as to form a close concentric joint with the adjoining section and to avoid offsets in the flow line.
- F. Clean and inspect each pipe and fitting before joining. Align pipe with previously laid sections. Assemble to provide tight, flexible joints that permit movement caused by expansion, contraction, and ground movement. Assemble joints in accordance with the pipe manufacturer's instructions.
- G. Check each pipe installed as to line and grade in place. Correct deviation from line and grade immediately. A deviation from the designed line or grade as shown on the drawings will be cause for rejection.
- H. Place and compact sufficient backfill to hold each section of pipe firmly in place as the pipe is laid. For storm sewers laid at slopes of 15% or greater, construct concrete anchors as shown in Standard Detail YT 03050-2.

### 3.03 BACKFILLING TRENCHES

- A. Backfill pipeline trenches only after examination of pipe by the Municipality.
- B. Backfill and compact trenches as specified in Section 02221.

### 3.04 PAVEMENT BASE DRAINS AND PIPE UNDERDRAINS

- A. Construct drains of the size and type indicated on the drawings in accordance with the requirements set forth in Section 610, Publication 408 Specifications.

### 3.05 SURFACE RESTORATION

- A. Restore unpaved areas in accordance with Section 02221.
- B. Restore other areas in accordance with Section 02575.

END OF SECTION

SECTION 02630

INLETS, MANHOLES, AND ENDWALLS

PART 1 GENERAL

1.01 DESCRIPTION

A. The work of this section includes, but is not limited to:

1. Storm sewer inlets
2. Manholes - precast and cast-in-place
3. Endwalls

B. Related work specified elsewhere:

- |   |               |
|---|---------------|
| 1. Trenching, backfilling and compacting:       | Section 02221 |
| 2. Soil erosion and sediment pollution control: | Section 02270 |
| 3. Storm drain pipe:                            | Section 02618 |
| 4. Plain and reinforced cement concrete:        | Section 03000 |
| 5. Cement concrete for utility construction:    | Section 03050 |

C. Definitions: NONE

D. Applicable Standard Details:

- YT 02630-1 Inlet/Storm Pipe Installation Detail
- YT 02630-2 Cast-in-Place Manhole Details
- YT 02630-3 Precast Manhole Base Details
- YT 02630-4 Shallow Manhole Detail

1.02 QUALITY ASSURANCE

A. Reference Standards:

1. Pennsylvania Department of Transportation (PennDOT), latest revision:

- Publication 408, Specifications
- Publication 72M, Standards for Roadway Construction

2. American Society for Testing and Materials (ASTM):

- A36 Specification for Carbon Structural Steel
- A47 Specification for Ferritic Malleable Iron Castings
- A48 Specification for Gray Iron Castings
- A185 Specification for Steel Welded Wire Fabric for Concrete Reinforcement
- A536 Specification for Ductile Iron Castings
- A615 Specification for Deformed and Plain Billet-Steel Bars for Concrete Reinforcement
- C32 Specification for Sewer and Manhole Brick (made from clay or shale)
- C270 Specification for Mortar for Unit Masonry

- B221 Specification for Aluminum and Aluminum Alloy Extruded Bars, Rods, Wire, Profiles and Tubes
- C139 Specification for Concrete Masonry Units for Construction of Catch Basins and Manholes
- C443 Specification for Joints for Circular Concrete Sewer and Culvert Pipe, Using Rubber Gaskets
- C478 Specification for Precast Reinforced Concrete Manhole Sections
- C923 Specification for Resilient Connectors Between Reinforced Concrete Manhole Structures, Pipes and Laterals

3. Federal Specifications (FS):

SS-S-00210 Sealing compound, preformed plastic, for expansion joints and pipe joints.

B. Inspections:

1. Inspections of the manholes by the Municipality will, at a minimum, be made of materials upon delivery to the job site; of the subgrade, prior to manhole base construction or placement; and of the completed manhole, prior to backfill.
2. Inspections of the frame and covers by the Municipality will be made upon delivery to the job site; and of the completed installation, prior to backfill.
3. A final inspection of the manhole channels, steps, frames and covers, and all joints will be performed upon completion of all testing, roadway restoration, and/or seeding.
4. Manholes shall be subject to rejection for failure to conform with these specifications or if any one of the following conditions is noted:
  - a. Fractures or cracks passing through the wall, except for a single end crack that does not exceed the depth of the joint.
  - b. Defects that indicate incorrect proportioning, mixing, and molding.
  - c. Surface defects larger than 1/2" diameter indicating honey-combed or open texture.
  - d. Damaged or cracked ends, where such damage would prevent making a satisfactory joint.
  - e. Any continuous crack having a surface width of 0.01 inches or more and extending for a length of 6 inches or more, regardless of position in the section wall.

C. Concrete Testing (For Cast-In-Place Work) - As specified in Section 03000.

1.03 SUBMITTALS

A. Certificates:

1. Submit two copies of certification from material suppliers attesting that materials meet or exceed specification requirements.

B. Shop Drawings:

1. Submit details of manhole sections, and precast bases if used.
2. Submit details of manhole frames and covers, including required lettering.
3. Submit details of adjusting rings.
4. Submit details of manhole steps.
5. Submit manufacturer's descriptive literature for joint sealant compounds.

1.04 JOB CONDITIONS

A. As specified in Section 02221.

1.05 PRODUCT DELIVERY, STORAGE AND HANDLING

A. Precast Concrete Units:

1. After fabrication and curing, transport the units to the job site. Protect until required for installation.
2. Handle to avoid damage to surfaces, edges and corners and to avoid creation of stresses within the units.

B. Inspections

1. Inspection by the Municipality will, at a minimum, be made of materials upon delivery to the job site; of the subgrade, prior to construction or placement; and of the completed structure, prior to backfill.
2. Precast cement concrete products shall be subject to rejection for failure to conform with these specifications or if any one of the following conditions is noted:
  - a. Fractures or cracks passing through the wall, except for a single end crack that does not exceed the depth of the joint.
  - b. Defects that indicate incorrect proportioning, mixing, and molding.
  - c. Surface defects larger than ½" diameter indicating honey-combed or open texture.
  - d. Damaged or cracked ends, where such damage would prevent making a satisfactory joint.
3. Concrete Testing (For Cast-In-Place Work): Section 03000.

PART 2 PRODUCTS

2.01 MATERIALS

A. Crushed Stone Subbase:

1. AASHTO No. 57, Type C, Crushed Stone or Gravel aggregate, Section 703.2, Publication 408 Specifications.

B. Masonry Mortar: ASTM C270, Type S.

C. Malleable Iron Castings: ASTM A47, Grade 35018, Domestic.

D. Ductile Iron Castings: ASTM A536, Grade 60-40-18, Domestic.

E. Structural Grade Carbon Steel: ASTM A36.

F. Cast-in-Place Cement Concrete: Section 03050.

G. Cast Gray Iron Castings: ASTM A48.

## 2.02 STORM SEWER INLETS

### A. Precast Cement Concrete Units

1. Comply with the requirements of Section 714, Publication 408 Specifications. Concrete shall be Class AA, unless otherwise specified.
2. All reinforcing shall comply with the requirements of Publication 72M.
3. 6' inlets shall be similar in all respects to standard inlets except that the longitudinal dimension shall be increased by 24".
4. Modified boxes (PennDOT Type 1, 2 or 3, Modified Type I or Modified Type II) shall have reinforced cover adjustment slabs in accordance with Details in Publication 72M.

### B. Inlet Grates

1. Comply with the requirements of Publication 72M, PennDOT approved vane, diagonal or bicycle safe grates.
2. Grates for 6' inlet shall be similar in all respects to standard inlet grates except that the longitudinal dimension shall be increased by 24".
3. Inlet grates in traffic areas shall be capable of handling HS-25 loading.
4. Welded structural steel grates and frames shall be coated with bituminous paint. All iron castings shall be furnished unpainted.
5. Inlets on roadways with longitudinal slopes equal to or greater than 4% shall have vane grates unless approved by Municipality.

### C. Outlet Structures

1. Precast concrete or cast-in-place concrete in accordance with Article 2.02.A.
2. Construct outlet structures to dimensions shown on the drawings.

## 2.03 PRECAST CONCRETE MANHOLE BASES AND SECTIONS: ASTM C478

- A. 5.5%  $\pm$  1.5% air-entrained cement concrete.
- B. Eccentric cone or flat slab top sections; minimum 24" access opening.
- C. Precast riser sections of length to suit.
- D. Precast bases of a design similar to the precast riser sections.
- E. Manholes shall have a 4' inside diameter unless otherwise noted on the drawings.
- F. Precast manhole bases shall be manufactured in accordance with the elevations shown on the Municipality's grade sheets and shall accommodate lateral hookups as marked in the field.
- G. Precast manhole bases and precast concrete channels shall be constructed specifically for the work intended.
- H. Joint Sealant Compound: FS SS-S-00210, preformed, flexible, self-adhering, cold-applied. Joints between manhole base and riser, between risers, between riser and cone, between cone and adjusting rings and cast iron frame, shall be made of RUB'R-NEK, a flexible plastic gasket-type sealant manufactured by K. T. Snyder Company, Inc., of Houston, Texas, or approved equal.

- I. Rubber Gaskets: ASTM C443
- J. Non-shrink Grout: Fastsetting, cement-based mortar such as Waterplug, manufactured by Thoro Division of ChemRex, Shakopee, MN, or approved equal.

#### 2.04 MANHOLE STEPS

- A. Manhole steps shall be made of non-corrosive aluminum, or steel reinforced fiberglass or polypropylene materials. Steps in precast walls shall terminate 1" from outer surface and shall be cast in place wherever possible or grouted with a waterproof, non-shrink grout.
  - 1. Aluminum alloy steps (Alloy 6061-T6) shall be Model No. F-140, manufactured by Washington Aluminum Company, Inc. of Baltimore, MD, or approved equal and shall have a protective coating consisting of asphalt coating conforming to AASHTO M-190 requirements applied to the portion to be embedded in the concrete.
  - 2. Steel reinforced fiberglass steps shall be Model No. 115 manufactured by R.J. Manufacturing, Inc. of San Antonio, Texas, or approved equal.
  - 3. Steel reinforced copolymer polypropylene plastic steps shall be Model No. PS-2-B or PS-2-PFS, manufactured by M. A. Industries, Inc. of Peachtree City, Georgia, or approved equal.

#### 2.05 MANHOLE FRAMES AND COVERS

- A. Domestic soft, gray cast iron castings: ASTM A48, Class 35B or better; free of bubbles, sand and air holes, and other imperfections. Castings shall be furnished unpainted.
- B. Frames and covers shall be capable of withstanding an AASHTO HS-25 loading and shall have a minimum 21" clear opening. Watertight frames and covers shall meet AASHTO HS-20 loading requirements.
- C. Frame and cover shall have machined bearing surfaces and matched to insure against rocking.
- D. Cover shall be lettered or marked "Storm Sewer" as appropriate.
- E. Standard frames and covers shall be similar to Model No. 1835 manufactured by East Jordan Iron Works, Inc., or Model 1255B manufactured by Bridgestate Foundry Corp., or approved equal. Manhole cover shall be 3" thick. Covers shall be self-sealing, have two (2) concealed watertight pick holes, and shall have two (2) lifting rings or bars, and no openings to permit surface water entry.
- F. Watertight frames and covers shall have suitable clamp, employing a rubber gasket seal, similar to Model No. 1120Z1 manufactured by East Jordan Iron Works, Inc., or Model 1032 manufactured by Bridgestate Foundry, or approved equal.

#### 2.06 ADJUSTING RINGS (MANHOLES AND INLETS)

- A. Precast cement concrete grade adjustment rings shall be cast from 4000 psi concrete (28-day compressive strength), shall be a maximum of 2" thick per ring. Circumferential reinforcement shall be in conformance with ASTM C478. Split concrete rings are not permitted. Concrete rings are permitted as approved by Engineer.



- B. HDPE adjusting rings and recycled rubber adjustment rings, manufactured by GNR Technologies may be used with prior approval from the ENGINEER. Rings shall be tapered to suite field conditions to result in cover (frame) elevation c" maximum below roadway grade.
- C. Metal adjusting rings are not permitted.
- D. For manholes, construct cast-in-place concrete riser to set frame at final grade of binder course unless otherwise requested by Engineer.

## 2.07 ENDWALLS

- A. Precast concrete: Publication 408, Section 714
- B. Cast-in-place concrete: Class A

## PART 3 EXECUTION

### 3.01 EXCAVATION

- A. Excavate as specified in Section 02221 at location marked in the field.
- B. Excavate to the required depth and grade for the bottom of the unit plus that excavation necessary for placement of base material.

### 3.02 INLET AND ENDWALL CONSTRUCTION

- A. Construct inlets and catch basins of either precast cement concrete sections or of cast-in-place cement concrete, and of the type indicated on the drawings.
  - 1. Place precast units on a minimum 12" compacted AASHTO No. 57 crushed aggregate base.
  - 2. Construct cast-in-place units on undisturbed earth.
  - 3. Shape bottom of inlet boxes to channel flow of water to the outlet pipe and to prevent water from standing in box or as directed.
  - 4. Unless units are cast-in-place, use precast cement concrete grade adjustment risers to adjust to grade. Mortar in place. Recycled rubber adjustment risers may be used with prior approval.
  - 5. Place appropriate grates in all paved (present or future) areas.
- B. Construct endwalls to the dimensions and design indicated on Standard Drawing RC-31M, Publication 72M, and of the type shown on the drawings. Construct endwalls of monolithically cast reinforced concrete.
- C. Do not permit pipes to project more than 2" into inlets. Do not expose end of pipe through faces of endwalls. Do not insert bell end of pipe into inlet.
- D. Inlet grates in new streets shall be flush with wearing course. Final grate elevation shall be at final street surface elevation.
- E. Pour concrete collars on outside of box around pipe at entry.

### 3.03 MANHOLE CONSTRUCTION

- A. Locate new manholes to be at the roadway centerline, center of a travel lane or behind the curb.
- B. Place a minimum of 4" thick compacted crushed stone base. Provide cast-in-place concrete or precast concrete bases.
  - 1. Construct cast-in-place bases as shown on Standard Detail YT 02630-2.
    - a. Cast-in-place bases may be constructed with a special form for a joint to match the manhole cylinder sections.
  - 2. Install precast bases as shown on Standard Detail YT 02630-3.
    - a. Set the precast base on the crushed stone base.
    - b. Provide a sealed, flexible resilient connection between pipe and precast base section.
- C. Form flow channels in manhole bases. Slope channels uniformly from influent invert to effluent invert, minimum 0.1' drop. Form channel sides and invert smooth and uniform, free of cracks, holes or protrusions.
- D. Do not permit pipe to project more than 2" into the manhole. Pour concrete collars on outside of manhole around pipe at entry.
- E. Where special gaskets or water stops are recommended by pipe manufacturers for connections at manhole walls, these facilities shall be provided. All pipe connection joints shall be watertight.
- F. Seal joints between precast concrete manhole sections with preformed rubber gaskets or joint sealant compound.
  - 1. Place joint sealant compound on both sections to be compressed by the weight of the upper section.
  - 2. Place rubber gasket in groove formed in spigot end. Equalize gasket tension.
- G. Step placement:
  - 1. Install manhole sections with steps in proper vertical alignment. Distance from top of rim to top step shall not be greater than 22". Distance from floor of manhole to bottom step shall not be greater than 24".
  - 2. Manhole steps shall be placed perpendicular to the mainline channel. Do not locate steps over channels.
- H. Install manhole frames and covers.
  - 1. In all streets and private roadways the top rim elevation of all manhole frames and covers shall be depressed 1/4" below the elevation of the adjacent street surface.
  - 2. Seal joint between manhole frame and manhole with joint sealant compound.
  - 3. All manholes in paving shall be adjusted to grade of binder course by constructing a concrete collar and anchoring frame with threaded steel rods. Use adjusting rings for the final adjustment of manhole cover to finished (wearing course) elevation.

4. If the proper adjustment cannot be achieved by the use of two rings, the cone section shall be removed and the proper barrel section inserted.
5. All concrete adjusting rings shall be parged and plastered on the inside and outside with cement mortar one-half (½") inch in thickness, carefully spread and thoroughly troweled to a smooth surface on the inside only.
6. Install other (non-concrete) types of adjusting rings in accordance with the manufacturer's recommendations.

I. New manholes constructed on existing pipelines:

1. Only cast-in-place manhole bases shall be installed over existing storm sewers, unless prior approval is obtained from the Engineer.
2. Carefully excavate around existing pipeline for placement of the new manhole base.
3. Take all measures necessary to control flow through the existing pipeline and to prevent leakage into the new base.
4. After completion of the manhole, carefully saw and remove the top portion of the existing pipeline.
5. No materials, construction debris, or ground and surface water shall enter the existing pipelines.

3.04 BACKFILLING

- A. Backfill structures only after inspection by the Municipality.
- B. Perform backfilling and compaction as specified in Section 02221.

3.05 DISPOSAL OF EXCAVATED MATERIAL: Section 02221.

3.06 RESTORATION OF SURFACE AREAS

- A. Restore paved areas in accordance with Section 02575.
- B. Restore unpaved surfaces as specified in Section 02221.

END OF SECTION

K:\094990003\dwg\DETAILS - MAY 2015\DETAILS (original in autocadd)\YT02630-1.dwg, 8/10/2015 8:03:06 AM

4' OR 6' INLET

VOIDS AROUND STORM PIPE & INLET WALL SHALL BE SEALED WITH CONCRETE AND A CLEAN SMOOTH FINISH PROVIDED ON INTERIOR WALL OF INLET.

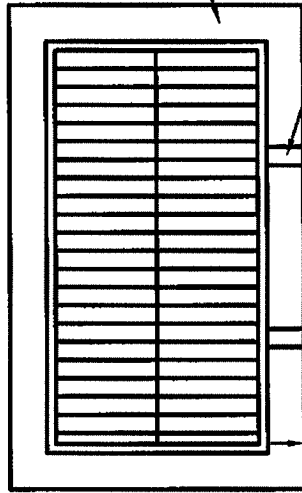

HIGH SLUMP CONCRETE COLLAR

STORM SEWER PIPE

±12"

PLAN VIEW

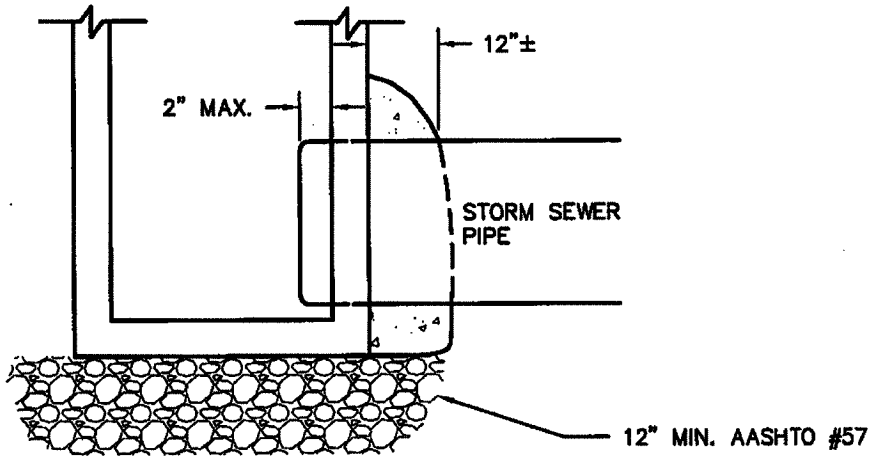

2" MAX.

12"±

STORM SEWER PIPE

12" MIN. AASHTO #57

ELEVATION

REVISED 5/20/2015  
NOT TO SCALE

**YORK TOWNSHIP CONSTRUCTION & MATERIALS SPECIFICATIONS**

YORK TOWNSHIP BOARD OF COMMISSIONERS  
190 OAK ROAD  
DALLASTOWN, PENNSYLVANIA 17313  
TELEPHONE: 717-741-3861 FAX: 717-741-5009

**INLET/STORM PIPE  
INSTALLATION DETAIL**

DATE:	1/24/2005
DRAWN BY:	ARB
CHK. BY:	
NO.	YT 02630-1

K:\094990003\dwg\DETAILS - MAY 2015\DETAILS (original in autocad)\YT02630-2.dwg, 8/10/2015 8:09:29 AM

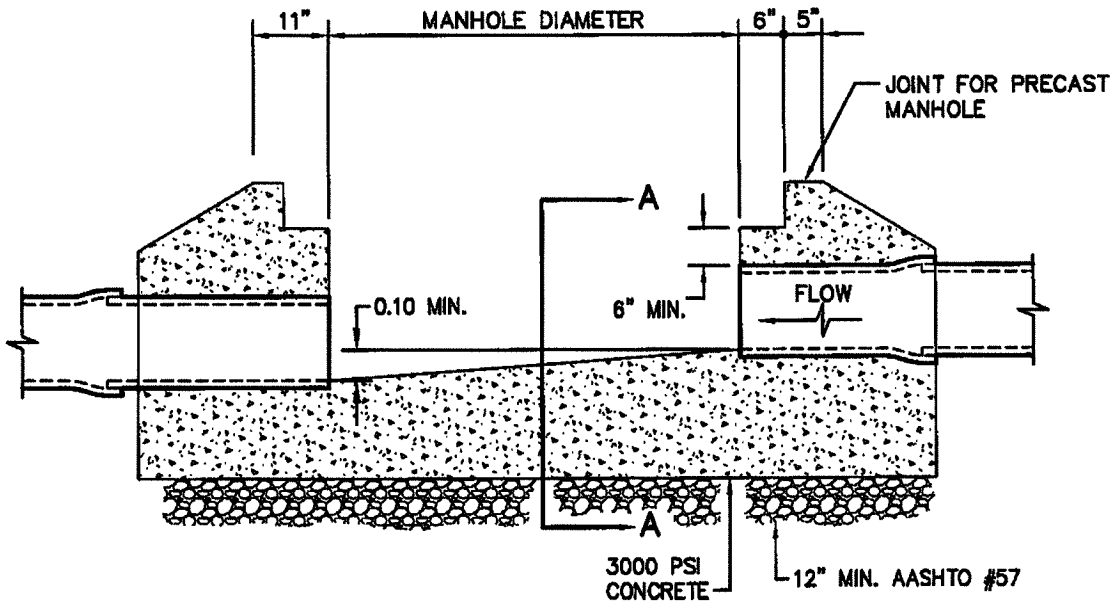

**ELEVATION**

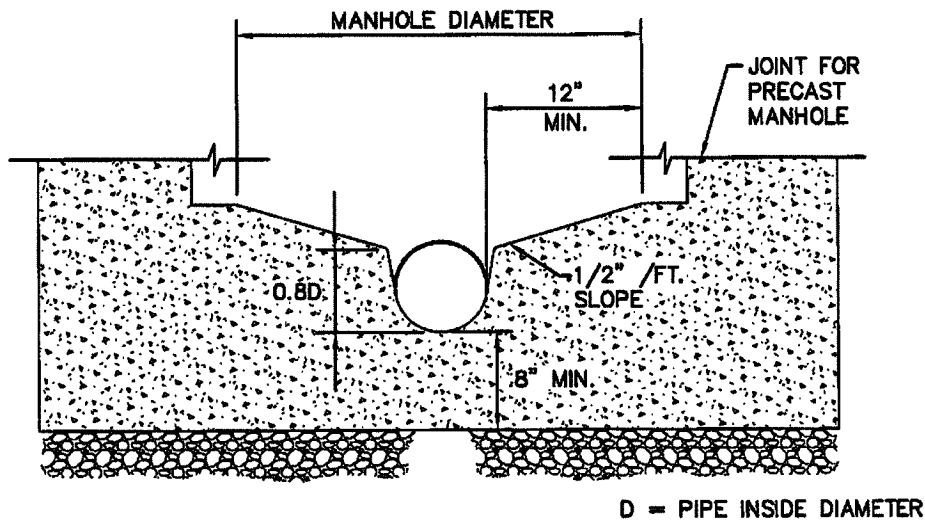

**SECTION A-A**

REVISED 5/20/2015  
NOT TO SCALE

**YORK TOWNSHIP CONSTRUCTION & MATERIALS SPECIFICATIONS**

**YORK TOWNSHIP BOARD OF COMMISSIONERS**  
190 OAK ROAD  
DALLASTOWN, PENNSYLVANIA 17313  
TELEPHONE: 717-741-3861 FAX: 717-741-5009

**CAST-IN-PLACE  
MANHOLE BASE DETAILS**

DATE: 1/24/2005  
DRAWN BY: ARB  
CHK. BY:  
NO. YT 02630-2

K:\094990003\dwg\DETAILS - MAY 2015\DETAILS (original in autocadd)\YT02630-3.dwg, 8/10/2015 8:10:18 AM

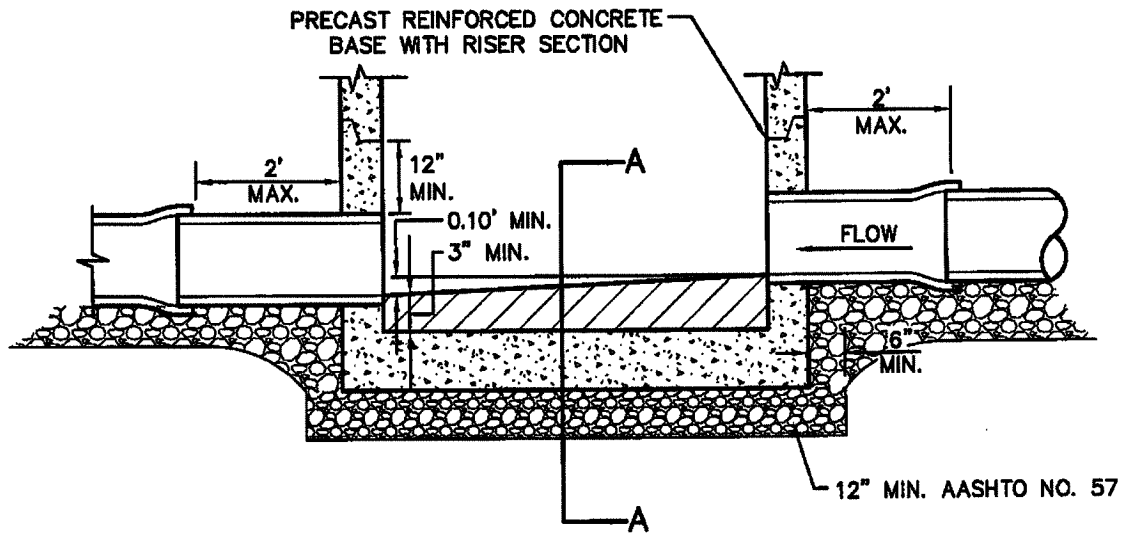

**ELEVATION**

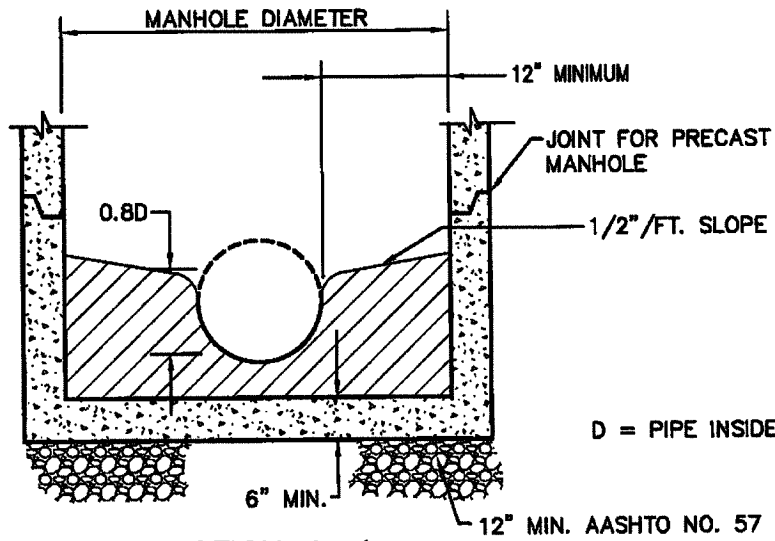

**SECTION A-A**

REVISED 5/20/2015  
NOT TO SCALE

**YORK TOWNSHIP CONSTRUCTION & MATERIALS SPECIFICATIONS**

<p><b>YORK TOWNSHIP BOARD OF COMMISSIONERS</b> 190 OAK ROAD DALLASTOWN, PENNSYLVANIA 17313 TELEPHONE: 717-741-3861 FAX: 717-741-6009</p>	<p><b>PRECAST MANHOLE BASE DETAILS</b></p>	DATE: 1/24/2005
		DRAWN BY: ARB
		CHK. BY:
		NO. YT 02630-3

K:\094990003\dwg\DETAILS - MAY 2015\DETAILS (original in autocadd)\YT02630-4.dwg, 8/10/2015 8:10:50 AM

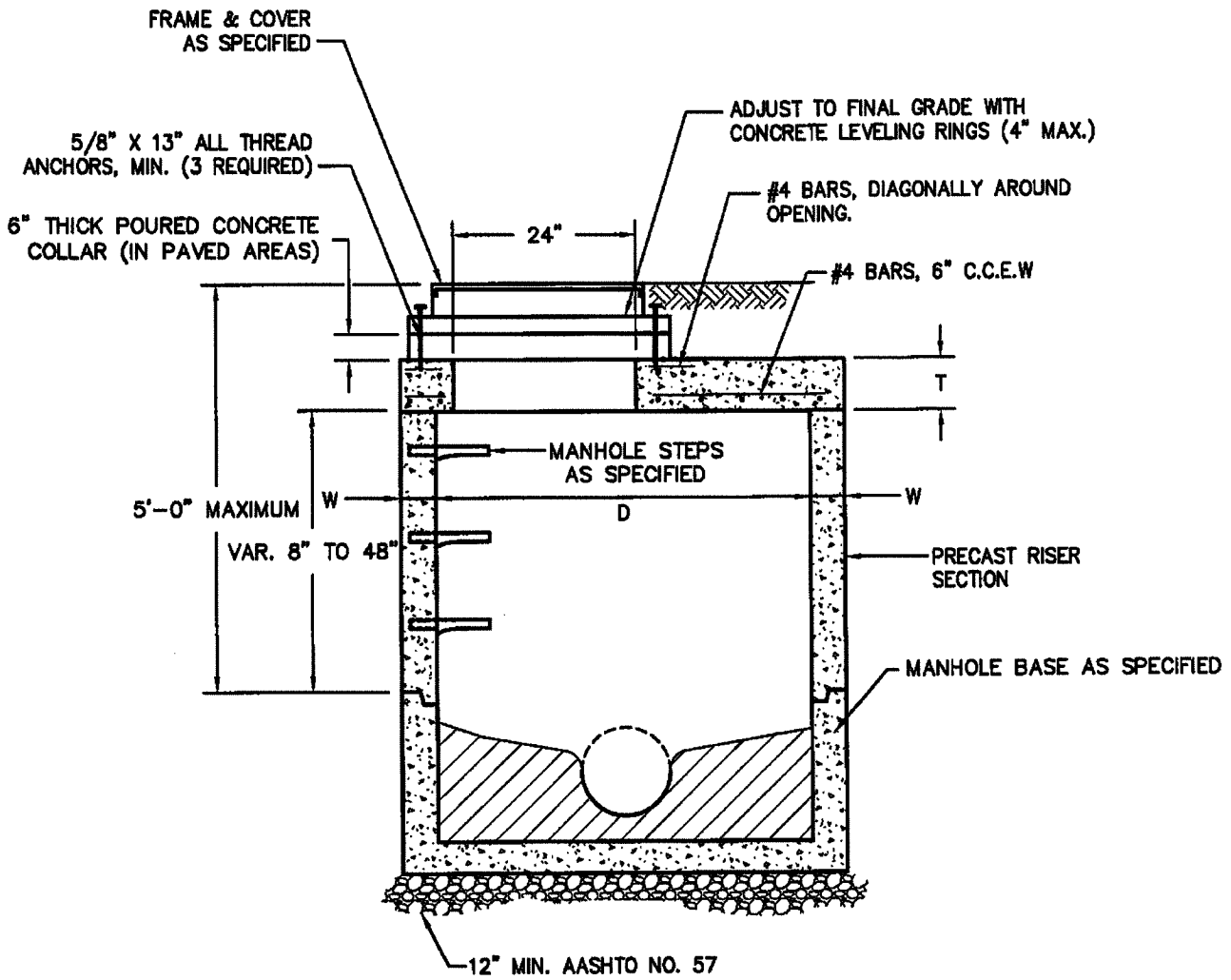

D	W	T
4'-0"	5"	6"
5'-0"	6"	8"
6'-0"	7"	8"

REVISED 5/20/2015  
NOT TO SCALE

**YORK TOWNSHIP CONSTRUCTION & MATERIALS SPECIFICATIONS**

**YORK TOWNSHIP BOARD OF COMMISSIONERS**  
190 OAK ROAD  
DALLASTOWN, PENNSYLVANIA 17313  
TELEPHONE: 717-741-3861 FAX: 717-741-8009

**SHALLOW  
MANHOLE DETAIL**

DATE: 1/24/2005  
DRAWN BY: ARB  
CHK. BY:  
NO. YT 02630-4

## SECTION 02640

### VALVES AND FIRE HYDRANTS

#### PART 1 GENERAL

- 1.01 The work of this section includes the installing and repairing of water valves and fire hydrants.
- 1.02 All public water mains in the Municipality are owned and maintained by The York Water Company, the Dallastown-Yoe Water Authority, or the Red Lion Municipal Authority.
- 1.03 Ownership and maintenance of fire hydrants in York Township is as follows:
  - A. Dallastown-Yoe Water Authority: Township owns and maintains.
  - B. Red Lion Municipal Authority: Township owns; utility maintains at Township expense
  - C. York Water Company: Utility owns and maintains.

#### PART 2 PRODUCTS

- 2.01 PIPE FITTINGS AND APPURTENANCES
  - A. All materials shall be in accordance with the requirements of the governing water company.
- 2.02 HYDRANT MARKERS
  - A. High visibility, weather proof, reflective marker (60" high) for mounting on each hydrant. Color as approved by Municipality.
  - B. Manufacturer: RoDon Corporation, or approved equal.
- 2.03 FIRE HYDRANTS
  - A. Depending on service area, all materials shall be in accordance with the requirements of the Dallastown Yoe Water Authority, Red Lion Municipal Authority or The York Water Company.

#### PART 3 EXECUTION

- 3.01 All work shall be performed in accordance with the requirements of the governing water company.

END OF SECTION



SECTION 02642

WATER SERVICE CONNECTIONS

PART 1 GENERAL

- 1.01 The work of this section includes tapping mains for water services and installing service piping to the curb stops or meter boxes.
- 1.02 All public water mains in the Municipality are owned and maintained by The York Water Company, the Dallastown-Yoe Water Authority, or the Red Lion Municipal Authority.

PART 2 PRODUCTS

- 2.01 All materials shall be in accordance with the requirements of the governing water company.

PART 3 EXECUTION

- 3.01 All work shall be performed in accordance with the requirements of the governing water company.

END OF SECTION

SECTION 02760  
PAVEMENT MARKINGS

PART 1 - GENERAL

1.01 DESCRIPTION

- A. The work of this section includes, but is not limited to:
  - 1. Application of traffic lines, markers or legends on roadway surfaces.
  - 2. Removal of any conflicting pavement markings.
- B. Related Work Specified Elsewhere: None
- C. Applicable Standard Details: None

1.02 QUALITY ASSURANCE

- A. Reference Standards:
  - 1. Pennsylvania Department of Transportation (PennDOT), latest edition of the following:
    - Publication 408, Specifications
    - Publication 68M, Subchapter K - markings
  - 2. American Society for Testing and Materials (ASTM):
    - D868 Standard Method of Evaluating Degree of Bleeding of Traffic Paint
    - D1309 Standard Test Method for Settling Properties of Traffic Paint During Storage
  - 3. The Institute of Transportation Engineers (ITE):
    - “A Model Performance Specification for the Purchase of Pavement Marking Paints and  
and Powders”, approved September 25, 1977.
  - 4. American Association of State Highway and Transportation Officials (AASHTO):
    - M249 White and Yellow Reflective Thermoplastic Striping Materials (Solid Form)
  - 5. Manual on Uniform Traffic Control Devised for Streets and Highways, latest edition  
(MUTCD).
- B. Qualifications: Installer shall specialize in application of traffic lines and pavement markings  
and shall have 5 years documented experience in Pennsylvania.

## 1.03 SUBMITTALS

### A. Certification

1. Submit letter of certification from the paint manufacturer stating that traffic line paint supplied meets either PennDOT's requirements or the referenced ITE spec. This letter shall accompany the delivery of the material and be given to the Municipality prior to the installation of pavement markings.
2. Manufacturer's product data for thermoplastic marking materials.

## 1.04 JOB CONDITIONS

### A. Control of Traffic:

1. Take measures to control traffic during line painting operations. Line painting machine shall not appreciably impede traffic flow in adjacent lanes while painting centerline and one lane shall be left completely open to traffic when painting edge lines.
2. Employ traffic control measures in accordance with Publication 213, Temporary Traffic Control Guidelines.

### B. Temperature and Weather Restrictions:

1. Painted traffic lines and markings shall not be placed when the ambient temperature is less than 40 degrees Fahrenheit.
2. Cold plastic markers or legends shall be applied only when the surface temperature is 60 degrees Fahrenheit or higher unless otherwise directed by the Municipality.

### C. Protection of Painted Surfaces:

1. Crosswalks, stop bars, symbols, legends, centerlines, and lane lines applied with conventional paint shall require coning (wet line protection) for a minimum of 30 minutes or until the paint becomes track free from vehicular traffic.

### D. Environmental Requirements:

1. Adhere to manufacturer's data on air and surface temperature limits and relative humidity during application and curing of coatings. Schedule coating work to avoid dust and airborne contaminants.

## PART 2 - PRODUCTS

### 2.01 PAINT

- A. Paint shall consist of either an alkyd resin type or a combination of alkyd resin type modified with chlorinated rubber ready-mixed white and yellow traffic paints, for use on bituminous and Portland cement concrete pavements. These paints shall be reflectorized for night visibility, if specified, by adding glass beads before the paint dries or sets, using the drop-on or pressurized methods.

- B. Traffic paint shall consist of a ready-mixed pigmented binder in a one package system. When applied at the wet-film thickness of 15 mils, the paint shall be suitable for application to traffic bearing surfaces such as Portland cement concrete, bituminous pavements, and plain or vitrified brick surfaces of streets, highways, bridges, tunnels and parking lots.
- C. The supplier may use any combination of pigments provided the finished paint meets all the requirements specified herein. Sufficient suspending and dispersing agents shall be used to prevent excessive settling as specified herein.
- D. Binder: The supplier may use any combination of ingredients, except tall oil resins, provided the finished paint meets all the requirements herein. Sufficient amounts of anti-skinning agents shall be used to prevent skinning as specified herein. Sufficient resin solids, compatible thinners and driers, if necessary, shall be used to meet project requirements.

## 2.02 GLASS BEADS

- A. Glass beads shall meet the requirements of Publication 408, Section 1103.14 (a)1. and all current supplements.

## 2.03 MATERIAL STORAGE

- A. Store the paint containers lid down. If the paint is used within two months after being received, no rotation prior to use is required. If the paint is on hand for more than two months, it shall be rotated several days before use.
- B. Glass beads shall be in units of 50 lbs. and packed in moisture-proof bags. The beads shall be stored in a cool dry place.

## 2.04 PREFORMED THERMOPLASTIC

- A. A durable, retro-reflective pavement marking material suitable for use as roadway, intersection, commercial or private delineation markings.
- B. The markings must be a resilient white or yellow hydrocarbon thermoplastic product with uniformly distributed glass beads throughout the entire cross sectional area. Lines, legends and symbols are capable of being affixed to bituminous and/or Portland concrete pavements by the use of the normal heat of a propane type of torch. Other colors shall be available as required.
- C. The markings must be capable of conforming to pavement contours, breaks and faults through the action of traffic at normal pavement temperatures. The markings shall have resealing characteristics, such that it is capable of fusing with itself and previously applied thermoplastic when heated with the torch.
- D. The markings must be able to be applied in temperatures down to 32 degrees F. without any special storage, preheating or treatment of the material before application.
- E. Must be composed to hydrocarbon resin, aggregates, pigments, binders and glass beads which have been factory produced as a finished product, which is designed to meet the requirements of the current edition of the Manual on Uniform Traffic Control Devices for Streets and Highways. The thermoplastic material conforms to AASHTO M249, with the exception of the relevant differences due to the material supplied in a preformed state.

- F. Graded Glass Beads: The material must contain a minimum of thirty percent (30%) graded glass beads by weight. The beads are clear and transparent. Not more than twenty percent (20%) consist of irregular fused spheroids, or silica. The index of refraction shall not be less than 1.50.
- G. Skid Resistance: The surface must provide a minimum resistance value of 55 BPN when tested according to ASTM E 303.
- H. Thickness: The material must be supplied at a minimum thickness of 125 mils  $\forall$  4 mils (3 mm).
- I. Environmental Resistance: The material must be resistant to deterioration due to exposure to sunlight, water, oil, gasoline, salt or adverse weather conditions.

## 2.05 MARKING TAPE

- A. Durable, conformable, retroreflective polymer marking capable of being adhered to pavement surface by a pre-coated pressure sensitive adhesive.
- B. Glass beads distributed throughout.
- C. Acceptable manufacturer: 3M Stamark High Performance Tape Series 380I.

## PART 3 - EXECUTION

### 3.01 APPLICATION

- A. Apply new pavement markings and “touch-up” existing markings within the limits of work, in accordance with drawings. The finished project shall match the drawings.

### 3.02 APPLICATION RATES FOR PAINTED MARKINGS

- A. Paint: Paint shall be dispensed in a wet film thickness of 15  $\pm$  1 mils. The rate of application of paint on bituminous surface treatment roads may be 25% greater. The Municipality will determine whether roadways require an increased application rate.
- B. Glass Beads: Glass beads shall be applied at a rate of six (6) pounds per gallon of paint.

### 3.03 SURFACE PREPARATION

- A. Clean the surface of the roadway before application of traffic lines or pavement markings to provide a clean, dry roadway surface which is free of loose dirt and other debris, to the satisfaction of the Municipality.
- B. Provide pretreatment as recommended by marking manufacturer.

### 3.04 EQUIPMENT FOR PAINTED MARKINGS

- A. The line painting machine type shall be such that it shall not appreciably impede the traffic flow in adjacent lanes while painting the centerlines of the roadway and one lane shall be left completely open to traffic when painting edge lines.

- B. The line-painting machines shall be capable of a simultaneous application of two parallel lines in either a solid or broken pattern in forming the centerline. It shall also be capable of the automatic dispensing of glass beads onto the painted surface at the required application rate, by the pressurized glass gun method.
- C. The machinery shall also be capable of providing a paint line in 4-inch, 6-inch and 8-inch widths.
- D. Each piece of machinery used to apply centerlines and edge lines shall be equipped with a measuring device which automatically and continuously measures to the nearest foot, the length of each line placed.
- E. Legends shall be applied with equipment approved by the Municipality; hand brushes or rollers are not permitted. Glass beads may be hand applied.

### 3.05 CENTERLINE APPLICATION

- A. Where existing centerlines are visible and properly located, the new centerlines shall be applied directly over the existing pattern. Where centerlines do not exist, or existing centerlines are improperly located, as determined by the Municipality, the new centerlines shall be applied at the correct location. If the existing markings have to be removed to allow correct placement of the new markings, such work shall be done in accordance with Section 963 (Pavement Marking Removal) of Publication 408. This work is incidental to the application of the new centerline.
- B. In general, on two-lane roadways, the centerline shall evenly divide the roadway; however, if a portion of the roadway on either or both sides is to be utilized for parking, the centerline shall evenly divide the traveled way.

### 3.06 EDGELINE APPLICATION

- A. Apply edge lines on roadways as required by the Municipality.

### 3.07 APPLICATION OF PREFORMED THERMOPLASTIC MARKING

- A. Asphalt: The materials shall be applied using the propane torch method recommended by the manufacturer. The material must be able to be applied at ambient and road temperatures down to 32 degrees F. without any preheating of the pavement to a specific temperature. The pavement shall be clean, dry and free of debris. Supplier must enclose application instructions with each box/package.
- B. Portland Concrete: The same application procedure shall be used as described under above paragraph 3.07 A. However, a compatible primer sealer may be applied before application to assure proper adhesion.
- C. The preformed thermoplastic markings shall be placed in protective plastic film with cardboard stiffeners where necessary to prevent damage in transit. Linear material must be cut to a maximum of 3 foot long pieces. The cartons in which packed shall be non-returnable and shall not exceed 40" in length and 25" in width, and be labeled for ease of identification.

3.08 ADHESIVE TAPE APPLICATION

- A. Apply in accordance with manufacturer's installation instructions, preferably in newly paved surfaces prior to public traffic being allowed on surface.

3.09 WARRANTY

- A. The Contractor shall guarantee to replace, at his expense, that portion of the pavement marking installed which, in the opinion of the Municipality, has not remained effective in performing useful daylight and nighttime service for a period of 6 months from the date of installation. The required service is defined as 90% of markings being effective and in place.

END OF SECTION

SECTION 02820  
FENCES

PART 1 - GENERAL

1.01 DESCRIPTION

A. The work of this section includes, but is not limited to the:

1. Installation of chain link fencing and gates.
2. Installation of wooden fences.

B. Related Work Specified Elsewhere:

1. Finish grading, seeding and sodding: Section 02485
2. Plain and reinforced cement concrete: Section 03000

C. Definitions: NONE

D. Applicable Standard Details: NONE

1.02 QUALITY ASSURANCE

A. Reference Standards:

1. American Society for Testing and Material (ASTM):

A53 Pipe, steel, black & hot-dipped, zinc coated, welded and seamless

A121 Zinc coated (galvanized) steel barbed wire

A123 Zinc (hot dipped galvanized) coatings on iron and steel products

A392 Zinc coated steel chain-link fence

F567 Practice for installation of chain-link fence

F626 Fence fittings

F043 Strength & protective coatings on metal industrial chain link fence framework

F1083 Pipe, steel, hot-dipped zinc coated (galvanized) welded for fence structures

2. Western Wood Products Association

1.03 SUBMITTALS

A. Manufacturer's catalogue cuts indicating material compliance.

1.04 JOB CONDITIONS

A. Locate and protect existing utilities as specified in Section 02210.

B. Exact location of fencing will be determined by the Contractor in consultation with the Municipality.



## 2.05 PRODUCTS DELIVERY, STORAGE AND HANDLING

- A. During loading, transporting and unloading, exercise care to prevent damage to materials.

## PART 2 - PRODUCTS

### 2.01 CHAIN LINK FENCING

#### A. Fabric

1. 2 inch diamond mesh of high quality medium carbon steel core wire, hot-dipped galvanized. Minimum tensile strength shall be 100,000 psi, 9 gage wire size.
2. Wire shall be imprinted with identification of manufacturer or trade name, country of origin, gage and tensile strength at 12" intervals.
3. Twist and barb top selvage. Twist and knuckle bottom selvage.

#### B. Posts

1. Line posts shall be 2-1/2" O.D. tubular steel pipe, SS40.
2. End, corner, angle or pull posts shall be 3" O.D. tubular steel pipe, SS40.
3. Gate posts shall be 4" O.D. tubular steel pipe or SS40, for each 7' - 12' gate leaf.
4. All posts shall be hot-dipped galvanized.

#### C. Framing and Bracing

1. Top rail and bracing rail shall be 1-5/8" O.D. tubular steel pipe (SS40), hot-dipped galvanized.
2. Bracing ends (for fastening to posts) shall be formed steel.
3. Truss rods shall be steel rods with minimum diameter of 3/8".
4. All framing shall be hot-dipped galvanized.

#### D. Concrete Bases - Concrete Minimum 28 Day Compressive Strength of 3,000 PSI.

#### E. Barbed Wire and Supports

1. Barbed wire shall be galvanized steel double wire strands, twisted. 4 point barbs shall be spaced approximately 3" on center.
2. Barbed wire supports shall be 12 gage pressed steel or malleable iron set 45E (inward or outward) from posts. Supports shall withstand 250 lbs. downward pull at end without failure.
3. Three rows bar bed wire shall be attached to supports.
4. Double "V" support arms, where specified, shall support 6 strands of barbed wire.

#### F. Hardware and Accessories

1. Top Rail Sleeves (for expansion and contraction of top rail) shall be 6" long.
2. Wire Ties - 9 gauge galvanized steel for line post attachment. Double wrap 13 gauge shall be used for attachments to rails and braces.
3. Nuts and Bolts shall be galvanized.
4. Post Caps shall be formed steel, cast malleable iron or aluminum alloy weather tight closure cap.

5. Tension Wire - 7 gauge core wire, galvanized, with tensile strength of 75,000 psi. Hog ring ties 12-1/2 gauge wire shall be used to tie fabric to tension wire.
6. Stretcher Bar - 3/16" x 2/4" steel bar or equivalent fiberglass rod. Length shall be 2" less than full height of fabric sheer fabric meets terminal posts.

#### G. Swing Gates

1. Gate frames shall be 2" O.D. tubular steel pipe SS40. Connections shall be welded to form rigid one-piece unit.
2. Hinges shall be structurally capable of supporting gate leaf and allow 180E of movement without binding. Non-lift-off type hinge design.
3. Latch - Forked type capable of retaining gate in closed position and have provision for padlock. Latch shall permit operation from either side of gate.
4. Keeper - Provide keeper for each leaf over 5' wide. Keeper shall secure free end of gate when fully open until manually released.
5. For double leaf gates, provide drop rod to hold inactive leaf and gate stop pipe to engage center drop rod.
6. Padlock - Provide one padlock to lock both gate leaves with 3 keys. Lock shall conform to Fed. Spec. FF-P-10 lb Type EPA with chain.
7. Gate posts shall have heavy ornamental caps.

#### H. Sliding Gates

1. Gate posts shall be a minimum of 3" O.D. tubular pipe, SS40. Additional steel bracing as required.
2. Rollers shall cantilever from posts.
3. Gate stop, padlock, and operator as required.

### 2.02 WOOD FENCE

- A. Western red cedar, white cedar or redwood for posts, rails and vertical planks.
- B. Other wood as approved by the Municipality.

### 2.03 OTHER MATERIALS

- A. PVC fence with wire mesh or vegetative fences may be constructed in required areas if approved by Municipality.

## PART 3 - EXECUTION

### 3.01 GENERAL

- A. Ensure property lines and legal boundaries of work are clearly established.
- B. Grade areas to receive fencing to eliminate surface irregularities to maintain required clearance.
- C. Install 4' high fence around stormwater basins and pools or ponds containing at least 24 inches of water. Higher fence shall be installed as otherwise directed.
- D. Install fence on or behind retaining walls that are six feet or higher.

### 3.02 CHAIN LINK FENCE

#### A. Posts

1. Place terminal post at each fence termination and change in horizontal, or vertical direction of 30E or more. Space line posts at equidistance spaces minimum 8', 10' maximum on centers.
2. Drill holes in firm, undisturbed or compacted soil. Holes shall have diameter 4 times greater than outside dimension of post and depth approximately 6" deeper than bottom of post (42" minimum depth). Excavate deeper as required for adequate support in soft or loose soils and for posts with heavy lateral loads.
3. Place concrete around posts in a continuous pour. Top of concrete shall be 1"-2" above surrounding grade and sloped to direct water away from posts. Maintain position of post (vertically and horizontally) during placement operations.
4. If solid rock is encountered during drilling, core drill a hole 1" larger in diameter than post and 12" deep. Grout the post in place.

#### B. Bracing

1. Install horizontal brace at mid-height for fences 6 feet and higher on each side of terminal posts. Install diagonal truss rods, at same posts, adjusting to ensure posts remain plumb.
2. Connect top rails with sleeves. Install bottom rails if required.
3. Install tension wire at bottom of fabric before stretching fabric and attach to each post with ties.

#### C. Fabric

1. Attach fence fabric so that fabric remains in tension after pulling force is released. Allow 2" clear space between finished ground and bottom selvage.
2. Attach fabric to bracing, rails and line posts with wire ties  $\pm$  15" on center. Attach fabric to tension wire, if any, with hog ties at 24" on center.
3. Bend ends of wire ties to minimize hazard to persons.
4. Thread tension bar through taut fabric and attach bar to terminal posts with bands or clips spaced at 15".

D. Barbed Wire - Uniformly space strands of barbed wire on the support arms. Each strand shall be pulled taut and securely fastened by clips or in slots of each support.

#### E. Gates

1. Swinging gates - Set posts in concrete and attach fabric. Locate and place gate stops so that drop rod fully engages. Attach hardware by means which will prevent unauthorized removal. Adjust hardware for smooth operation of gate leaves.
2. Sliding gates - Set posts, rollers, framing and bracing for smooth operation. Place gate stops. Adjust hardware.

### 3.02 WOOD FENCE

A. See Article 3.01.

B. Dig post holes at spacing recommended by manufacturer.

C. Erect fence posts and attach rails or vertical planks with proper fasteners.

3.03 OTHER FENCES

- A. If approved, construct PVC or vegetative fences around basins, pools, ponds or on top of retaining walls.
- B. Vegetative fences must be dense enough to prevent walking through. Acceptable, lockable gate required at basins, pools, and ponds.

3.04 CLEAN UP

- A. Clean up debris and unused material and remove from the site.

END OF SECTION

## SECTION 02852

### GUIDE RAIL

#### PART 1 GENERAL

##### 1.01 SCOPE OF WORK

A. The work of this section includes installation of steel guide rail along roadways, including any excavation, concrete work and restoration of paved or unpaved surfaces.

B. Related work specified elsewhere:

- |  |               |
|--|---------------|
| 1. Bituminous paving and surfacing:      | Section 02500 |
| 2. Plain and reinforced cement concrete: | Section 03000 |

##### 1.02 QUALITY ASSURANCE

A. Reference Standards:

1. Pennsylvania Department of Transportation (PennDOT) latest revisions:

- a. Publication 408, Specifications
- b. Publication 72M, Roadway Construction Standards (RC)

B. Qualifications

1. Guide Rail Installer - shall be a firm that specializes in this work, has minimum 5 years experience and is PennDOT pre-qualified to perform this work.

##### 1.03 JOB CONDITIONS

A. Control of traffic shall be in accordance with PennDOT Publication 213 Temporary Traffic Control Guidelines.

B. Protection of existing utilities and structures:

1. Take all precautions to protect existing utilities and structures. Comply with requirements of Pennsylvania Underground Utility Protection Law.
2. Advise each person operating power equipment for excavation of the type and location of utility lines at the job site.
3. Immediately notify utility owner and Municipality of any damage to a utility line.

#### PART 2 PRODUCTS

##### 2.01 GUIDE RAIL

A. All rail elements, posts, offset brackets, base plates, other hardware and end sections shall be in accordance with PennDOT Publication 408, Section 1109, including galvanizing.

2.02 ANCHOR BOLTS

- A. Anchor bolts shall be in accordance with Penn DOT Publication 408, Section 1105 and as shown on drawings.

2.03 CONCRETE

- A. Concrete for end anchorage shall be Class A cement concrete in accordance with PennDOT Publication 408, Section 704.

PART 3 EXECUTION

3.01 APPROACH GUIDE RAIL

- A. Ensure property lines and legal boundaries of work are clearly established.
- B. Remove any existing railing and install new guide rail in accordance with PennDOT Publication 408, Section 620.
- C. Install guide rail at the post spacings, lengths and with end treatments as shown on the Contract drawings. Restore ground surface to pre-existing conditions.

3.02 CLEAN UP

- A. Clean up debris and unused material and remove from the site.

END OF SECTION

SECTION 02891  
ROADWAY SIGNING

PART 1 GENERAL

1.01 DESCRIPTION

A. The work of this section includes, but is not limited to:

1. Sign post placement
2. Roadside signing

B. Related work specified elsewhere: NONE

C. Definitions: NONE

D. Applicable Standard Details: NONE

1.02 QUALITY ASSURANCE

A. Reference Standards:

1. Manual of Uniform Traffic Control Devices (MUTCD), latest revision
2. Pennsylvania Department of Transportation (PennDOT), latest revision  
Publication 408, Specifications

B. Inspection (if sign not installed by Municipality)

1. Municipality will inspect base installation and sign placement.

1.03 SUBMITTALS

A. Sign post, base and signage detail

1.04 JOB CONDITIONS

A. See Section 02500.

PART 2 PRODUCTS - Municipality will provide and install all posts and sign materials for developer. Developer will reimburse Township per fee schedule.

2.01 POSTS

A. Breakaway posts - Pub. 408, Sections 931 and 1103 - all streets.

B. Steel posts, square galvanized.

C. Length of post - as required to meet sign height for the street classification.

## 2.02 SIGNS

### A. Sheeting: AASHTO M268

1. Reflectivity: Diamond Grade or High Intensity Prismatic
2. Colors: Standard traffic colors (ASTM D4956) and daytime fluorescent yellow and yellow green meeting requirements of the MUTCD.

### B. If more than one size is available, size shall be as requested by the Municipality.

## 2.03 SIGN DETAILS

### A. All signs shall adhere to:

1. MUTCD, latest revision.
2. PADOT Pub 236M.
3. York Township Department of Public Works.

### B. All street name signs shall adhere to:

1. York Township Department of Public Works.
2. Public Street Signs: Blue with white lettering.
3. Private Streets: Brown with white lettering.

## PART 3 EXECUTION

### 3.01 INSTALLATION (STANDARD)

- #### A. Municipality shall install all required roadway signing at the developer's expense unless otherwise approved in writing prior to installation.

### 3.02 ALTERNATE INSTALLATION PROCEDURES

- #### A. Drive anchors into undisturbed earth with top of anchor four inches above ground on lower slope side.
- #### B. Install breakaway post anchors to depth required.
- #### C. If post is in concrete, place PVC sleeve by embedding in fresh concrete or drilling into existing concrete prior to installing post.
- #### D. Install at location shown on drawings or as directed by Municipality.
- #### E. Bolt post to anchor.
- #### F. Place correct sign of required size on post. Fasten securely with anti-theft hardware.

END OF SECTION



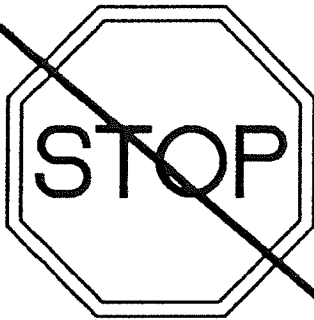

R1-1, 30"  
HIGH INTENSITY  
STOP SIGN

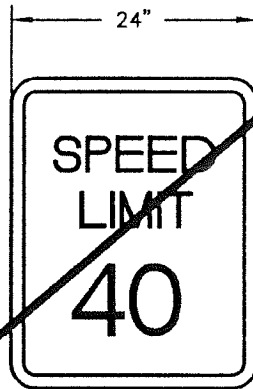

R2-1, 24"X30"  
SPEED LIMIT SIGN

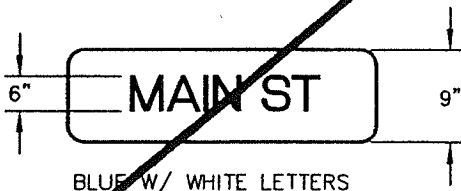

BLUE W/ WHITE LETTERS



BLUE W/ 6" WHITE LETTERS

STREET NAME SIGNS

SIGN DEATILS REMOVED

ALL SIGNS SHALL ADHERE TO:  
MUTCD  
PADOT PUB 236M  
YORK TOWNSHIP DEPARTMENT OF  
PUBLIC WORKS

ALL STREET NAME SIGNS SHALL ADHERE TO  
YORK TOWNSHIP DEPT. OF PUBLIC WORKS  
PUBLIC STREET SIGNS: BLUE W/ WHITE LETTERING  
PRIVATE STREET SIGNS: BROWN W/ WHITE LETTERING

YORK TOWNSHIP CONSTRUCTION & MATERIALS SPECIFICATIONS

YORK TOWNSHIP BOARD OF COMMISSIONERS  
190 OAK ROAD  
DALLASTOWN, PENNSYLVANIA 17313  
TELEPHONE: 717-741-3861 FAX: 717-741-5009

ROADWAY SIGN  
DETAILS

DATE:	03/30/09
DRAWN BY:	MJL
CHK. BY:	
NO.	YT 02891-1

SECTION 02901

LANDSCAPE PLANTING

PART 1 - GENERAL

1.01 DESCRIPTION

A. The work of this section includes, but is not limited to:

1. Furnishing and planting trees and shrubs.
2. Transplanting trees and shrubs.
3. Maintenance.
  
4. Fertilizing and mulching.

B. Related Work Specified Elsewhere:

1. Trenching, backfilling and compacting: Section 02221
2. Finish grading, seeding and sodding: Section 02485

C. Definitions: NONE

D. Applicable Standard Details:

1. PennDOT Publication 72M, Standards for Roadway Construction, latest revision.

1.02 QUALITY ASSURANCE

A. Reference Standards:

1. Horticultural Standards, Latest edition, of rules and grading, adopted by the American Association of Nurserymen.
2. Standardized Plant Names, American Joint Committee on Horticulture Nomenclature.

1.03 JOB CONDITIONS

A. Protect underground utilities and structures. Comply with local and State requirements to locate facilities to avoid damage.

1.04 PRODUCT DELIVERY, STORAGE AND HANDLING

A. Comply with local, State or Federal laws relative to plant material shipment.

## PART 2 - PRODUCTS

### 2.01 PLANT STOCK

- A. All plant material shall be true to type and name, in accordance with the current edition of Standardized Plant Names. Each plant or plant group shall be labeled with not less than the plants common name and size. Each plant shall be typical of the species or variety specified. All stock shall be free from disease, insect infestations, mechanical injuries, broken branches, or other defects and also meeting the following requirements.
1. Nursery Stock shall have been grown in a certified nursery for a period of at least two (2) full growing seasons. The use of mechanical digging equipment at the nursery will be permitted only when its use is not deemed detrimental to nursery stock survival.
  2. Collected Plants shall be obtained from native standard or established plantings.
  3. Balled and Burlapped Plants (B&B) shall have a firm ball composed of original, undisturbed soil, wrapped with untreated burlap and laced with biodegradable lacing to hold the root ball firm and intact. All Plants found with broken, loose, or manufactured root balls will be rejected.
  4. Container-Grown Plants shall have been grown for at least one (1) year, but not more than two (2) years, in the same container and shall not exist in a "pot-bound" condition.
  5. Bare Root Plants shall have a live, well-branched root system with moist, fibrous root hairs free from rot and mold.
- B. Plant material shall be handled, packed and stored using good nursery practices. Material shall be available for inspection in the nursery or collecting field before digging. The Municipality reserves the right to tag selected plants, indicating acceptable form, shape, and cultural practices, in compliance with detailed specifications.
- C. Any plant material which is designated as rejected material shall be segregated and removed from the planting site within 48 hours.

### 2.02 WRAPPING MATERIAL

- A. Approved wrapping material shall be krinkle-kraft waterproof paper 30-30-30 in 4" widths or approved equal.

### 2.02 FERTILIZER

- A. Commercial fertilizer shall conform to the requirements of the Pennsylvania Soil Conditioner and Plant Growth Substance Law, Act of December 1, 1977, P.L. 258, No. 86 (3P.S.68.2), as amended. Fertilizer shall have an analysis of 0-20-0, 23-10-5 (10 gram tablets) or 16-8-16 and shall be packaged in 4 ounce, individual, heat-sealed, polyethylene envelopes.

### 2.04 MULCH

- A. All mulch shall be free from foreign material, coarse stems, and any substances toxic to plant growth. Material shall be suitable, fibrous-ground, shredded, or chunk aged oak bark, not decomposed, between 1/4" and 2" in any dimension, unless otherwise approved by Municipality.
- B. Mulch shall be spread in 3" thick (min.) layer over a 2" thick (min.) layer or organic compost material.

## 2.05 BACKFILL MIX FOR PLANTINGS

- A. Backfill mix shall consist of a homogeneous mixture of 20% peat (either shredded reedsedge peat or sphagnum moss peat, or a combination of both from fresh water sites) and 80% topsoil by volume. One pound of 0-20-2 commercial fertilizer shall be uniformly mixed into each cubic yard of backfill mix.

## 2.06 STAKES AND GUYS

- A. Where required, stakes shall be rough-sawn, red or white cedar, southern yellow pine, or acceptable hardwoods free from knots, rot, or other defects which may impair the strength of the stake. Steel channel bar posts, rolled from Standard Carbon Steel Rails, and meeting ASTM-A499 may be used in lieu of wood stakes.
- B. Ground anchors shall be either a 4-inch Universal Ground Anchor, as manufactured by Laconia Malleable Iron or a 4-inch Auger Type Earth Anchor, as manufactured by American Steel Products Corp., or approved equal.
- C. All wire for bracing and guying trees shall be #12 gage, galvanized, and shall meet ASTM A392, Class II requirements.

## 2.07 TREE PROTECTORS

- A. All newly planted trees shall have a tree protector device installed around the base. The protector shall be corrugated polyethylene solid pipe (ASTM D1248, ASTM F405) of a minimum diameter of 2X greater than the caliper of the tree, and a length of 18". Galvanized steel or aluminum, perforated protectors may be used but must have a rubber hose guard lining at the top.
- B. Before placing, samples or manufacturers catalog cuts of the devices shall be submitted for review and acceptance.

## 2.08 HOSE GUARD

- A. To protect trees and shrubs from guy wire damage, an acceptable hose guard shall be utilized.

## 2.09 WEED BARRIER MAT

- A. When indicated, use a nonwoven 100% polyester fiber fabric manufactured for this specific purpose.

# PART 3 - EXECUTION

## 3.01 TEMPORARY STORAGE

- A. All plant material not planted immediately shall be properly stored. Obtain, provide, and prepare a suitable healing-in site or arrange for a well-ventilated and cool storage shed located near the planting site. Temporarily store container-grown or balled and burlapped plants in a protected area, with containers or balls 6 inches apart. Fill all voids with moist mulch to the top of the container or ball.

- B. Bare root plant material which arrives at the planting site shall be immediately removed from the transport vehicle. Roots shall be covered with wet burlap or mulch to prevent drying. Protect the plant material from sun and wind and keep fresh by the fine mist spraying, or by other acceptable methods.
- C. Protect plants at all times. All material left out of the ground, unprotected overnight, with roots exposed to sun and wind, or unprotected during transit, unloading, storage, healing in or during actual planting operations will be rejected.

### 3.02 LAYOUT OF PLANTINGS

- A. Delineate the plant pit locations, bed and planting area outlines. Identify the plants to be placed at the delineated locations. Do not start excavation or cultivation until the locations and outlines have been accepted by the Municipality.
- B. Should obstructions prevent planting at the indicated locations, alternate locations or deletions will be determined by the Municipality.

### 3.03 SHRUB BED PREPARATION

- A. For areas indicated for bedding, prepare the area in the following manner to attain the designed finished grade:
  - 1. Remove sod and all undesirable growth, add additional topsoil if required to re-establish grade.
  - 2. Uniformly spread 3 inches of peat, then thoroughly incorporate it into the soil to a minimum depth of 6 inches. As directed during this blending operation, remove and dispose of undesirable material larger than 2 inches in any dimension.

### 3.04 PREPARATION OF PLANT PITS

- A. For bare root shrubs, vines, and seedling transplants, dig pits with vertical sides and flat bottoms large enough to accommodate roots without crowding. For balled and burlapped plants, the pit shall be twice the width of the ball diameter. For common periwinkle, pachysandra, and ivy, provide only 4 inches of backfill mix beneath and around all sides of the root system.
- B. All plant pits designated for bare root or balled and burlapped plant stock shall be dug prior to removing plants from temporary storage. Immediately before planting, scarify, loosen, or roughen the sides of the plant pit.
- C. If the soil conditions are deemed favorable to healthy plant growth, the Municipality may direct the Contractor to dig the pit up to three (3) times the root spread or balled diameter.

### 3.05 PRUNING

- A. Typical top pruning, as directed, shall be performed appropriate for each species, variety, size, or planting location. Typical pruning samples will serve as a guide for subsequent pruning throughout the project.
- B. Broken or badly bruised branches shall be removed with a clean cut. Pruning cuts over 3/4" in diameter shall be painted over with approved tree paint.

- C. Prune the tops of deciduous shrubs prior to or immediately following planting. Prune according to best horticultural practices regarding natural or desired form and growth characteristics of the individual species. Unless otherwise directed, remove one-fourth to one-third of the potential leaf bearing surface from deciduous plants. Only trim or thin evergreens when and as directed.
- D. Root pruning shall only be performed to remove damaged or broken main roots. Cut immediately above the damage with a clean oblique cut.

## PLANTING

- A. Planting shall be performed when soil and climatic conditions are favorable, and according to the following schedule. Where local conditions warrant and at the direction of the Municipality, these dates may be extended:
  - 1. Deciduous Trees and Shrubs: October 15 - May 15
  - 2. Evergreen Trees: March 1 - May 15  
August 1 - September 15
  - 3. Seedlings and Seedling Transplants: March 1 - May 15
- B. Plants shall be set plumb and at the specified depth. Plant material shall be handled by the packaging material and not by the stem or branches. Remove plant containers or preformed root protection devices which restrict root development immediately prior to planting. Balled and burlapped material shall be placed in the plant pits intact.
- C. Bare root material shall be planted immediately. To prevent root drying, use wet burlap, straw, hay or other protective measures.
- D. Fertilize in accordance with the fertilizer schedule. Cultivate and completely tamp back fill mix around the ball or roots, in a manner that fills voids and eliminates air pockets. Use extreme care to avoid damaging roots during backfilling and tamping operations. When backfilling is two-thirds complete, on balled and burlapped material cut the lacing around the main stem or trunk then lay the burlap back. Thoroughly water the plant. After absorption of all water, complete the backfill operation and water again.
- E. Where indicated, install the weed barrier mat to match the diameter of the plant pit or other designated area and staple. Mulch area as required.
- F. Wrap deciduous shade and flowering tree trunks from the ground line to the lowest main branches, overlapping the wrap 1" - 1½". Tie the wrapping at the top middle, and bottom and at a minimum of two other places.
- G. If staking and guying is required, perform that operation immediately after completion of backfilling.
- H. Install tree protectors around the base of deciduous and flowering trees with the bottom of the protector extending through the mulch and being in contact with the backfill material.

3.07 MAINTENANCE OF PLANTING

- A. All plants shall be maintained in healthy living conditions until the entire project has been accepted. Plants are required to be growing in place at least 30 days prior to project acceptance. During this period of establishment, perform necessary maintenance functions such as weeding, spraying, remulching and watering as required or directed.
- B. Watering shall be performed during the period of establishment promptly and with sufficient personnel and equipment to complete any directed operation within five (5) calendar days of such direction. Furnish measurements and capacities of water tanks to be used in the watering operation along with a watering schedule for approval.
- C. Tighten guys and stakes that may become loosened.

3.08 CLEAN UP

- A. The planting site shall be left in an acceptable condition, with all debris and undesirable excavated material satisfactorily removed from the site and suitable disposed of. The acceptable condition may also require seeding and mulching of disturbed areas within the limits of work.

3.09 REPLACEMENT

- A. Within the 30-day establishment period and prior to acceptance of the project, all plants determined by the Municipality not to be alive or in a healthy condition shall be replaced with plants of the same species, size, and quality as originally indicated and specified. Replacements may be directed to be made at the beginning or the next planting season.

END OF SECTION

## SECTION 03000

### PLAIN AND REINFORCED CEMENT CONCRETE

#### PART 1 GENERAL

##### 1.01 DESCRIPTION

A. The work of this section includes, but is not limited to, the following:

1. Construction of cast-in-place plain and reinforced cement concrete structures
2. Concrete curbs and sidewalks
3. Trench restoration of concrete roadways and driveways.
4. Testing of cast-in-place concrete for curbs, sidewalks and utility related structures

B. Related Work Specified Elsewhere:

1. Cement concrete curb and sidewalk: Section 02525
2. Cement concrete for utility construction: Section 03050

C. Definitions:

1. Exposed construction - Permanently exposed to view.
2. Concrete - Normal weight concrete for which density is not a controlling attribute, made with aggregates of the types covered by ASTM C33, and having unit weights in the range of 135 to 160 lb. per cubic foot.
3. f<sub>c</sub> - The design compressive strength of the hardened concrete at an age of 28-days.

D. Applicable Standard Details: NONE

##### 1.02 QUALITY ASSURANCE

A. Reference Standards:

1. American Concrete Institute (ACI):

ACI 117 Standard Specifications for Tolerance for Concrete Construction and Materials  
ACI 301 Specifications for Structural Concrete.  
ACI 315 Details and Detailing of Concrete Reinforcement.  
ACI 318 Building Code Requirements for Structural Concrete.

2. American Society for Testing and Materials (ASTM):

A185 Specification for Steel Welded Wire Fabric, Plain, for Concrete Reinforcement  
A615 Specification for Deformed and Plain Billet-Steel Bars for Concrete Reinforcement  
C31 Practice for Making and Curing Concrete Test Specimens in the Field  
C33 Specification for Concrete Aggregates  
C39 Test Method for Compressive Strength of Cylindrical Concrete Specimens  
C42 Test Method of Obtaining and Testing Drilled Cores and Sawed Beams of Concrete



- C94 Specification for Ready-Mixed Concrete
- C138 Test Method for Unit Weight, Yield, and Air Content (Gravimetric) of Concrete
- C143 Test Method for Slump of Hydraulic Cement Concrete
- C150 Specification for Portland Cement
- C171 Specification for Sheet Materials for Curing Concrete
- C172 Practice for Sampling Freshly Mixed Concrete
- C173 Test Method for Air Content of Freshly Mixed Concrete by the Volumetric Method
- C192 Practice for Making and Curing Concrete Test Specimens in the Laboratory
- C231 Test Method for Air Content of Freshly Mixed Concrete by the Pressure Method
- C260 Specification for Air-Entraining Admixtures for Concrete
- C309 Specification for Liquid Membrane-Forming Compounds for Curing Concrete
- C494 Specification for Chemical Admixtures for Concrete
- D698 Test Method for Laboratory Compaction Characteristics of Soil Using Standard Effort (12,400 ft-lb/ft<sup>3</sup>)
- D994 Specification for Preformed Expansion Joint Filler for Concrete (Bituminous Type)
- D1751 Specification for Preformed Expansion Joint Filler for Concrete Paving and Structural Construction (Nonextruding and Resilient Bituminous Types)
- D1752 Specification for Preformed Sponge Rubber and Cork Expansion Joint Fillers for Concrete Paving and Structural Construction
- E329 Specification for Agencies Engaged in the Testing and/or Inspection of Materials used in Construction

3. National Ready-Mixed Concrete Association, 900 Spring Street, Silver Spring, MD 20910: Check list for certification of ready-mixed concrete production facilities.

B. Testing Agencies:

1. Testing services shall be performed by an independent testing agency acceptable to the Municipality at the Contractor's expense. All testing agencies shall meet the requirements of ASTM E329.

1.03 SUBMITTALS

- A. Submit manufacturer's or supplier's certification for the following materials verifying compliance with these Specifications:
  1. Portland cement
  2. Coarse and fine aggregates
  3. Any specified concrete admixtures
  4. Reinforcing steel
  5. Joint forming and filling materials
  6. Form coating materials
  7. Concrete curing compounds
- B. Submit concrete mix designs, including strength test records, for review and approval.
- C. Submit certified results of compressive strength cylinder tests.

- D. Submit copies of concrete batch slips.

## PART 2 PRODUCTS

### 2.01 CONCRETE

- A. Cement - Unless otherwise specified, portland cement shall be Type I cement conforming to ASTM C150.
- B. Aggregates - Aggregates for normal weight concrete shall meet the requirements of ASTM C33.
- C. Water - Mixing water for concrete shall be clean, potable water meeting the requirements of ASTM C94.
- D. Admixtures - Concrete admixtures, when required and/or approved for use by the Municipality, shall conform to the following Specifications:
  - 1. Air-entraining admixtures - ASTM C260.
  - 2. Water-reducing, retarding and accelerating admixtures - ASTM C494.

### 2.02 REINFORCEMENT

- A. Reinforcing Bars - All reinforcing bars shall be deformed, except spirals, which may be plain bars. Reinforcing bars shall be Grade 60, billet-steel conforming to the requirements of ASTM A615, including supplementary requirement on the drawings.
- B. Welded Wire Fabric - Welded wire fabric shall be fabricated from smooth or deformed wire of the size and spacing required on the drawings and shall conform to the requirements of ASTM A185, except welded intersections shall be spaced not farther apart than 12 inches in the direction of the principal reinforcement.

## PART 3 EXECUTION

### 3.01 PROPORTIONING

- A. General - Concrete for all parts of the work shall be of the specified quality and capable of being placed without excessive segregation. When hardened, concrete shall develop all characteristics required by these Specifications.
- B. Strength - Unless otherwise specified, the minimum 28-day compressive strength of the concrete,  $f_c$ , shall be 3000 psi.
- C. Durability - All concrete which will be subjected to potentially destructive exposure, including freezing and thawing, weather, and/or deicer chemicals, shall be air-entrained and shall conform to the air content limits in ACI 301 moderate exposure.

### 3.02 REINFORCEMENT

- A. Welding - Welding of crossing bars (tack welding) for assembly of reinforcement is prohibited.

B. Fabricate and place all reinforcing in accordance with ACI 117.

### 3.03 EMBEDDED ITEMS

- A. All sleeves, inserts, anchors, and embedded items required for adjoining work or for its support shall be placed prior to concreting.
- B. All Contractors whose work is related to the concrete or must be supported by it shall be given ample notice and opportunity to introduce and/or furnish embedded items before the concrete is placed.
- C. Placing Embedded Items - Expansion joint material, waterstops, and other embedded items shall be positioned accurately and supported against displacement. Voids in sleeves, inserts, and anchor slots shall be filled temporarily with readily removable material to prevent the entry of concrete into the voids.

### 3.04 PRODUCTION OF CONCRETE

- A. Production Method - All concrete shall be ready-mixed concrete batched, mixed and transported in accordance with ASTM C94. Plant equipment and facilities shall conform to "Certification of Ready-Mixed Concrete Production Facilities (Checklist with Instructions)" of the National Ready-Mixed Concrete Association.
- B. When concrete arrives at the project with slump below that suitable for placing, as indicated by the Specifications, water may be added only if neither the maximum permissible water-cement ratio nor the maximum slump is exceeded. The water shall be incorporated by additional mixing equal to at least half of the total mixing required. Discharge of the concrete shall be completed within 1-1/2 hours, or before the truck drum has revolved 300 revolutions, whichever comes first, after the introduction of the mixing water to the cement and aggregates or the introduction of the cement to the aggregates. Truck batch slips must include time of batching, total drum revolutions upon arrival at site, and quantity of water (in gallons) per cubic yard available to be added to attain the maximum design water-cement ratio.

### 3.05 PLACING

- A. Preparation Before Placing:
  - 1. Hardened concrete and foreign materials shall be removed from the inner surfaces of the conveying equipment.
  - 2. Formwork shall be completed; snow, ice and water shall be removed; reinforcement shall be secured in place; expansion joint material, anchors, and other embedded items shall be positioned; and the entire preparation shall be accepted.
  - 3. Concrete shall not be placed on frozen ground.
- B. Conveying:
  - 1. Concrete shall be handled from the mixer to the place of final deposit as rapidly as practicable by methods which will prevent segregation or loss of ingredients and in a manner which will assure that the required quality of the concrete is maintained.

2. Conveying equipment shall be of a size and design such that detectable setting of concrete shall not occur before adjacent concrete is placed. Conveying equipment shall be cleaned at the end of each operation or work day.
  - a. Truck mixers, agitators and non-agitating units and their manner of operation shall conform to the applicable requirements of ASTM C94.
  - b. Belt conveyors shall be horizontal or at a slope which will not cause excessive segregation or loss of ingredients. Concrete shall be protected against undue drying or rise in temperature. An acceptable arrangement shall be used at the discharge end to prevent segregation. Mortar shall not be allowed to adhere to the return length of the belt. Long runs shall be discharged into a hopper or through a baffle.
  - c. Chutes shall be metal or metal-lined and shall have a slope not exceeding 1 vertical to 2 horizontal and not less than 1 vertical to 3 horizontal. Chutes more than 20 ft. long and chutes not meeting the slope requirements may be used provided they discharge into a hopper before distribution.
  - d. Pumping or pneumatic conveying equipment shall be capable of pumping the specified mix with adequate pumping capacity. Pneumatic placement shall be controlled so that segregation is not apparent in the discharged concrete. The loss of slump in pumping or pneumatic conveying equipment shall not exceed 2 in. Concrete shall not be conveyed through pipe made of aluminum or aluminum alloy.

C. Depositing:

1. General - Concrete shall be deposited continuously, or in layers of such thickness that no concrete will be deposited on concrete which has hardened sufficiently to cause the formation of seams or planes of weakness within the section. If a section cannot be placed continuously, construction joints shall be located as indicated on the drawings. Placing shall be carried on at such a rate that the concrete which is being integrated with fresh concrete is still plastic. Concrete which has partially hardened or has been contaminated by foreign materials shall not be deposited.
2. Segregation - Concrete shall be deposited as nearly as practicable in its final position to avoid segregation due to rehandling or flowing. Concrete shall not be subjected to any procedure which will cause segregation.
3. Consolidation - All concrete shall be consolidated by vibration, spading, rodding or forking so that the concrete is thoroughly worked around the reinforcement, around embedded items, and into corners of forms, eliminating all air or stone pockets which may cause honey-combing, pitting, or planes of weakness. Internal vibrators used shall be the largest size and the most powerful that can be properly used in the work. They shall be operated by competent workmen. Use of vibrators to transport concrete within forms shall not be allowed. Vibrators shall be inserted and withdrawn at points approximately 18 in. apart. At each insertion, the duration shall be sufficient to consolidate the concrete but not sufficient to cause segregation, generally from 5 to 15 seconds. A spare vibrator shall be kept on the job site during all concrete placing operations. Where the concrete is to have an as-cast finish, a full surface of mortar shall be brought against the form by the vibration process, supplemented if necessary by spading to work the coarse aggregate back from the formed surface.

D. Protection:

1. Unless adequate protection is provided, concrete shall not be placed during rain, sleet or snow.

2. Rainwater shall not be allowed to increase the mixing water nor to damage the surface finish.
3. The temperature of the concrete as placed shall not be so high as to cause difficulty from loss of slump, flash set, or cold joints and should not exceed 90°F. When the temperature of the steel is greater than 120°F, steel forms and reinforcement shall be sprayed with water just prior to placing the concrete.

### 3.06 FINISHING OF FORMED SURFACES

- A. If the finish is not designated on the drawings, the following finishes shall be used as applicable:
  1. Rough form finish - For all concrete surfaces not permanently exposed. Tie holes and defects shall be patched and fins over 1/4" in heights rubbed off.
  2. Smooth rubbed finish - For all concrete surfaces permanently exposed. Apply on newly hardened concrete within one day following form removal. Surfaces shall be wetted and rubbed until uniform color and texture are produced.

### 3.07 SLABS

- A. General - Concrete for slabs shall be as specified in Article 3.01.
- B. Preparation of Subgrade for Slabs on Ground:
  1. The subgrade shall be well drained and of adequate and uniform load-bearing capacity. The minimum in-place density of the subgrade soils shall be not less than 95% of its maximum dry weight density at its optimum moisture content, plus or minus 2%, as determined by ASTM D698.
  2. The subgrade shall be free of frost before concrete placing begins. If the temperature inside a building where concrete is to be placed is below freezing it shall be raised and maintained above 50°F long enough to remove all frost from the subgrade.
  3. The subgrade shall be moist at the time of concreting. If necessary, it shall be dampened with water in advance of concreting, but there shall not be standing water on the subgrade nor any muddy or soft spots when the concrete is placed.
- C. Finishes
  1. Floated finish - After the concrete has been placed, consolidated, struck off, and leveled, the concrete shall not be worked further until ready for floating. Floating with a hand float or with a bladed power trowel equipped with float shoes, or with a powered disc float shall begin when the water sheen has disappeared and when the surface has stiffened sufficiently to permit the operation. During or after the first floating, planeness of surface shall be checked with a 10-ft. straightedge applied at not less than two different angles. All high spots shall be cut down and all low spots filled and the slab shall then be refloated immediately to a uniform sandy texture.
  2. Broom or belt finish - Immediately after the concrete has received a float finish, it shall be given a coarse transverse scored texture by drawing a broom or burlap belt across the surface.
  3. Unspecified Finish - When type of finish is not specified on the drawings, use broom finish.

### 3.08 CURING AND PROTECTION

A. General - Beginning immediately after placement, concrete shall be protected from premature drying, excessively hot or cold temperatures, and mechanical injury, and shall be maintained with minimal moisture loss at a relatively constant temperature for the period necessary for hydration of the cement and hardening of the concrete.

B. Preservation of Moisture:

1. For concrete surfaces not in contact with forms, one of the following procedures shall be applied immediately after completion of placement and finishing:
  - a. Application of acceptable moisture-retaining covering as approved by the Municipality.
  - b. Application of a curing compound conforming to ASTM C309 - The compound shall be applied in accordance with the recommendations of the manufacturer immediately after any water sheen which may develop after finishing has disappeared from the concrete surface. It shall not be used on any surface against which additional concrete or other material is to be bonded unless it is proven that the curing compound will not prevent bond, or unless positive measures are taken to remove it completely from areas to receive bonded applications.
2. Moisture loss from surfaces placed against wooden forms or metal forms exposed to heating by the sun shall be minimized by keeping the forms wet until they can be safely removed. After form removal the concrete shall be cured.
3. Curing shall be continued for at least 7 days. Alternatively, if tests are made of cylinders kept adjacent to the structure and cured by the same methods, moisture retention measures may be terminated when the average compressive strength has reached 70 percent of the strength, *f*<sub>c</sub>. Moisture retention measures may also be terminated when the temperature of the concrete is maintained at least at 50°F for the same length of time that laboratory-cured cylinders, representative of the concrete in-place, require to achieve 85 percent of *f*<sub>c</sub>.

C. Temperature, Wind, and Humidity:

1. Cold weather - When the mean daily outdoor temperature is less than 40°F, the temperature of the concrete shall be maintained between 50° and 70°F for the required curing period. When necessary, arrangements for heating, covering, insulating, or housing the concrete work shall be made in advance of placement and shall be adequate to maintain the required temperature without injury due to concentration of heat. Combustion heaters shall not be used during the first 24 hr. unless precautions are taken to prevent exposure of the concrete to exhaust gases which contain carbon dioxide.
2. Hot weather - When necessary, provision for windbreaks, shading, fog spraying, sprinkling, ponding, or wet covering with a light colored material shall be made in advance of placement, and such protective measures shall be taken as quickly as concrete hardening and finishing operations will allow.
3. Rate of temperature change - Changes in temperature of the air immediately adjacent to the concrete during and immediately following the curing period shall be kept as uniform as possible and shall not exceed 5°F in any 1-hr. or 50°F in any 24-hr. period.

- D. Protection from mechanical injury - During the curing period, the concrete shall be protected from damage due to mechanical disturbances, such as load stresses, heavy shock, and excessive vibration. All finished concrete surfaces shall be protected from damage by construction equipment, materials or methods, by application of curing procedures, and by rain or running water.

### 3.09 TESTING

- A. General - Concrete materials and operations will be tested and inspected as the work progresses. Failure to detect any defective work or material shall not in any way prevent later rejection when such defect is discovered nor shall it obligate the Municipality for final acceptance.
- B. Testing Services - The following testing services shall be performed by the designated testing agency.
  - 1. Conduct strength tests of the concrete during construction in accordance with the following procedures:
    - a. Secure composite samples in accordance with ASTM C172. Each sample shall be obtained from a different batch of concrete on a random basis, avoiding any selection of the test batch other than by a number selected at random before commencement of concrete placement.
    - b. Mold and cure four specimens from each sample in accordance with ASTM C31. Any deviations from the requirements of this Standard shall be recorded in the test report.
    - c. Test the specimens in accordance with ASTM C39. Two specimens shall be tested at 28-days for acceptance and two shall be tested at 7-days for information. The acceptance test results shall be the average of the strengths of the two specimens tested at 28 days. If one specimen in a test manifests evidence of improper sampling, molding or testing, it shall be discarded and the strength of the remaining cylinder shall be considered the test result. Should both specimens in a test show any of the above defects, the entire test shall be discarded.
    - d. Make at least one strength test for each 50 cu. yd., or fraction thereof, of each mixture design of concrete placed in any 1 day.
  - 2. Determine slump of the concrete sample for each strength test and whenever consistency of concrete appears to vary, using ASTM C143.
  - 3. Determine air content of the concrete sample for each strength test in accordance with either ASTM C231, ASTM C173, or ASTM C138.
  - 4. Determine temperature of the concrete sample for each strength test.
- C. Additional Services When Required - The following services shall be performed by the testing agency when required by the Municipality at the Contractor's expense:
  - 1. Inspect concrete batching, mixing and delivery operations to the extent deemed necessary by the Municipality.
  - 2. Sample concrete at point of placement and perform required tests.
  - 3. Review the manufacturer's report for each shipment of cement and reinforcing steel and conduct laboratory tests or spot checks of the materials as received for compliance with specifications.

4. Mold four specimens from each sample (in addition to those required above) in accordance with ASTM C31 and field cure in or on the structure providing the same method of cure for the specimens as that which the structure receives.
- D. Other Services as Needed - The following services shall be performed by the testing agency at the Contractor's expense:
1. Additional testing and inspection required because of changes in materials or proportions requested by the Contractor.
  2. Additional testing of materials or concrete occasioned by their failure by test or inspection to meet specification requirements.
- E. Duties and Authorities of Designated Testing Agency:
1. Representatives of the agency shall inspect, sample and test the materials and the production of concrete as required by the Municipality. When it appears that any material furnished or work performed by the Contractor fails to fulfill specification requirements, the testing agency shall report such deficiency to the Municipality and the Contractor.
  2. The agency shall report all test and inspection results to the Municipality and Contractor immediately after they are performed. All test reports shall include the exact location in the work at which the batch represented by a test was deposited. Reports of strength tests shall include detailed information on storage and curing of specimens prior to testing.
  3. The testing agency and its representatives are not authorized to revoke, alter, relax, enlarge or release any requirement of the specifications, nor to approve or accept any portion of the work.
- F. Responsibilities and Duties of Contractor:
1. The Contractor shall provide the necessary testing services for the following:
    - a. Qualification of proposed materials and the establishment of mixture designs.
    - b. Other testing services needed or required by the Contractor.
  2. The use of testing services shall in no way relieve the Contractor of the responsibility to furnish materials and construction in full compliance with the Contract Documents.
  3. The Contractor shall submit to the Municipality the concrete materials and the concrete mix designs proposed for use with a written request for acceptance. This submittal shall include the results of all testing performed to qualify the materials and to establish the mix designs. No concrete shall be placed in the work until the Contractor has received such acceptance in writing.
  4. To facilitate testing and inspection, the Contractor shall:
    - a. Furnish any necessary labor to assist the testing agency in obtaining and handling samples at the project or other sources of materials.
    - b. Advise the testing agency sufficiently in advance of operations to allow for completion of quality tests and for the assignment of personnel.
    - c. Provide and maintain for the sole use of the testing agency adequate facilities for safe storage and proper curing of concrete test specimens on the project site for the first 24-hrs. as required by ASTM C31.

END OF SECTION



## SECTION 03050

### CEMENT CONCRETE FOR UTILITY CONSTRUCTION

#### PART 1 GENERAL

##### 1.01 DESCRIPTION

A. The work of this section includes, but is not limited to cast-in-place cement concrete for:

1. Reaction and support blocking
2. Encasements
3. Miscellaneous utility related cast-in-place cement concrete construction

B. Related work specified elsewhere:

- |   |               |
|---|---------------|
| 1. Trenching, backfilling and compaction: | Section 02221 |
| 2. Trench paving and restoration:         | Section 02575 |
| 3. Inlets, manholes, and endwalls:        | Section 02630 |
| 4. Plain and reinforced cement concrete:  | Section 03000 |

C. Definitions: NONE

D. Applicable Standard Details:

- YT 03050-1 Concrete Encasement Detail
- YT 03050-2 Concrete Anchor Detail
- YT 03050-3 Special Concrete Encasement for Frost Protection Detail

##### 1.02 QUALITY ASSURANCE

A. Reference Standards:

1. Pennsylvania Department of Transportation (PennDOT), latest revision:  
Publication 408, Specifications

B. Inspections:

1. Inspections by the Municipality will, at a minimum, be made of the subgrade, formwork, supports, and reinforcement prior to placement of the concrete; and of the concrete prior to backfilling.

C. Testing:

1. As specified in Section 03000.

##### 1.03 SUBMITTALS

A. Submit concrete mix designs, including strength test records, for review and approval.

- B. Submit certified results of compressive strength cylinder tests.
- C. Submit copies of concrete batch slips.

## PART 2 PRODUCTS

### 2.01 CEMENT CONCRETE

- A. As specified in Section 03000.
- B. For work involving a time constraint, use PennDOT Class HES (High Early Strength).

### 2.02 REINFORCEMENT STEEL

- A. As specified in Section 03000.

## PART 3 EXECUTION

### 3.01 CONSTRUCTION

- A. Comply with Section 03000 for construction requirements including placement, curing, and protection of cement concrete.
- B. Excavate and shape trench bottoms and sides to accommodate encasements, manhole bases, drop connections, inlets and vaults.
- C. Support pipes, valves and fittings at the required elevation with brick or concrete block. Do not use earth, rock, wood, or organic materials as supports.
- D. Provide spacers, chairs, bolsters, ties and other devices for properly placing, spacing, supporting and fastening reinforcement in place.
- E. Place concrete utilizing all possible care to prevent displacement of pipes or fittings. Return displaced pipes or fittings to line and grade immediately.
- F. Do not backfill structures until concrete has achieved its initial set and forms are removed.
- G. Perform backfilling and compaction as specified in Section 02221.

END OF SECTION

K:\091990003\dwg\YT03050-1.dwg, 1/27/2005 10:12:16 AM

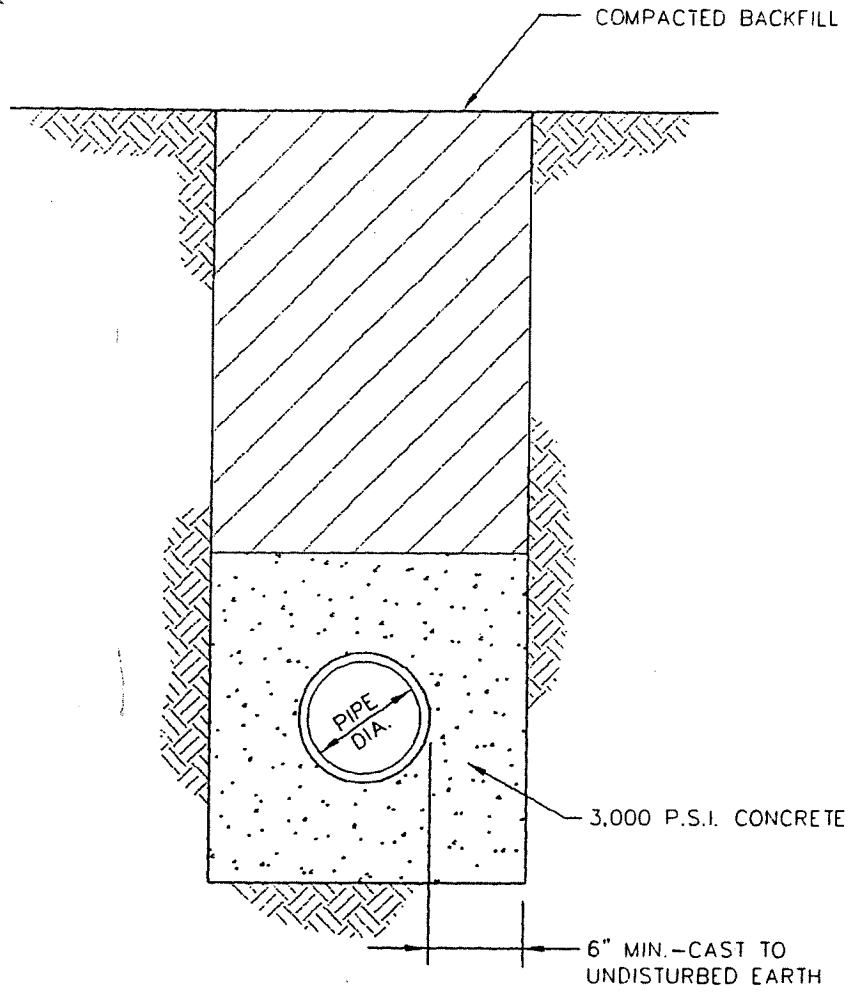

SECTION

NOTE: NOT TO SCALE

**YORK TOWNSHIP CONSTRUCTION & MATERIALS SPECIFICATIONS**

**YORK TOWNSHIP BOARD OF COMMISSIONERS**  
 190 OAK ROAD  
 DALLASTOWN, PENNSYLVANIA 17313  
 TELEPHONE: 717-741-3861 FAX: 717-741-5009

**CONCRETE  
 ENCASEMENT  
 DETAIL**

DATE:	1/24/2005
DRAWN BY:	ARB
CHK. BY:	SKS
NO.	YT 03050-1

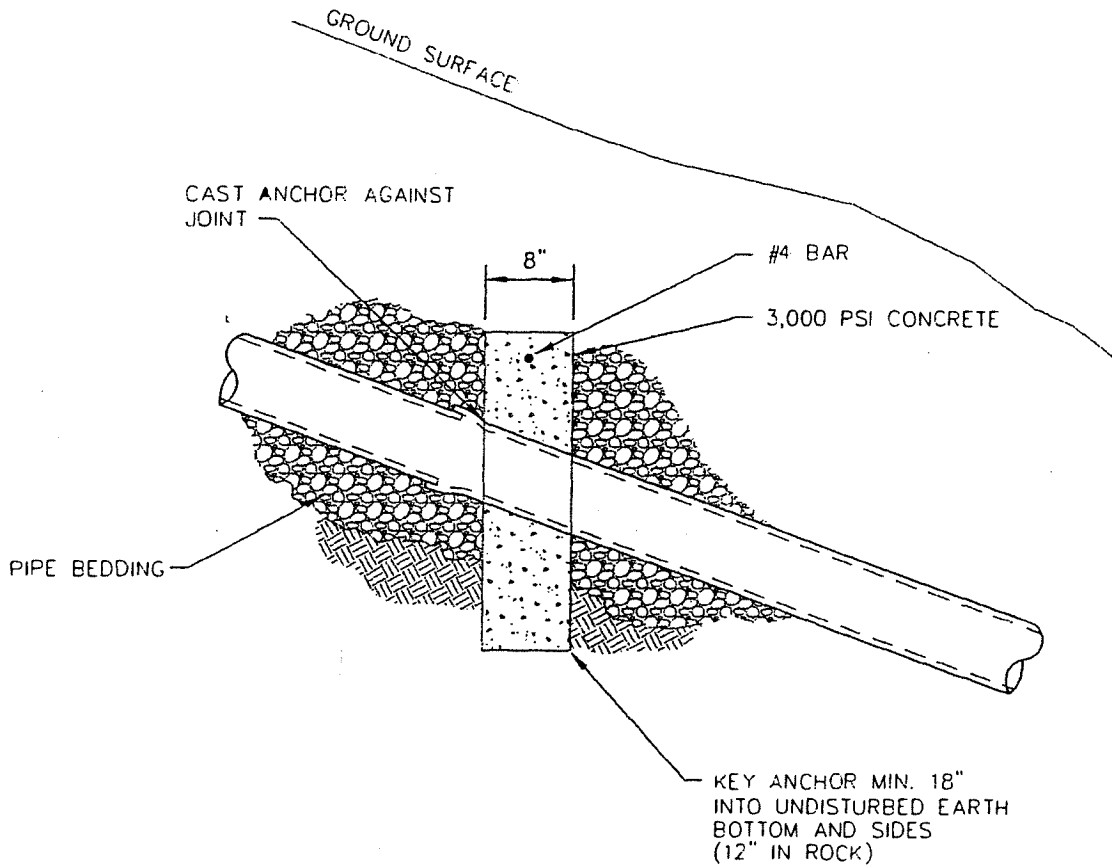

ELEVATION

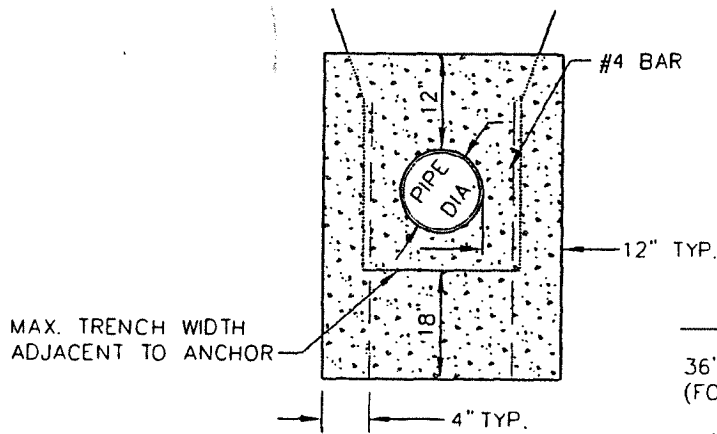

SECTION

MAXIMUM SPACING

- 36' O.C. 15% TO 20% SLOPES (FOR STORM SEWERS ONLY)
- 36' O.C. 20% TO 35% SLOPES
- 24' O.C. OVER 35% TO 50% SLOPES
- 16' O.C. OVER 50% SLOPES

NOTE: NOT TO SCALE

**YORK TOWNSHIP CONSTRUCTION & MATERIALS SPECIFICATIONS**

**YORK TOWNSHIP BOARD OF COMMISSIONERS**  
 190 OAK ROAD  
 DALLASTOWN, PENNSYLVANIA 17313  
 TELEPHONE: 717-741-3861 FAX: 717-741-5009

**CONCRETE ANCHOR  
 DETAILS**

DATE: 1/24/2005  
 DRAWN BY: ARB  
 CHK. BY: SKS  
 NO. YT 03050-2

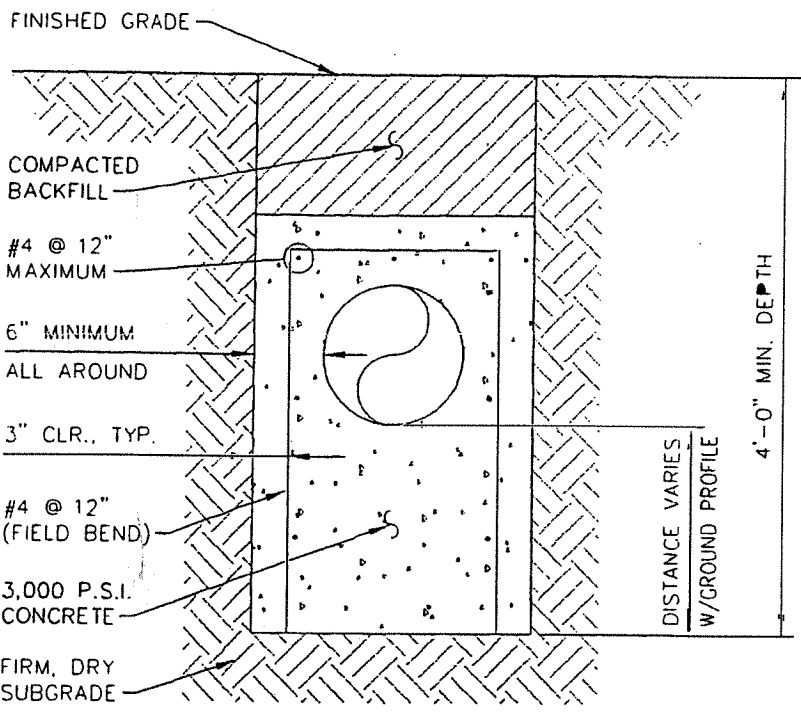

NOTES:

- STABILIZE PIPE & REINFORCEMENT WITHIN EXCAVATION TO PREVENT MOVEMENT DURING CONCRETE PLACEMENT.

NOTE: NOT TO SCALE

YORK TOWNSHIP CONSTRUCTION & MATERIALS SPECIFICATIONS

YORK TOWNSHIP BOARD OF COMMISSIONERS  
 190 OAK ROAD  
 DALLASTOWN, PENNSYLVANIA 17313  
 TELEPHONE: 717-741-3861 FAX: 717-741-5009

SPECIAL CONCRETE  
 ENCASEMENT  
 FOR FROST  
 PROTECTION DETAIL

DATE:	1/24/2005
DRAWN BY:	ARB
CHK. BY:	SKS
NO.	YT 03050-3

K:\091990003\dwg\YT03050-3.dwg. 1/27/2005 10:13:12 AM

SECTION 16500  
STREET LIGHTING

PART 1 - GENERAL

1.01 WORK INCLUDED

A. The Work of this Section includes, but is not limited to the installation of conduits, poles, controls, lighting fixtures, lamps and wire necessary for a complete and functioning street lighting system.

B. Related work specified elsewhere:

- |  |               |
|--|---------------|
| 1. Trenching, backfilling and compacting:    | Section 02221 |
| 2. Plain and reinforced cement concrete:     | Section 03000 |
| 3. Cement concrete for utility construction: | Section 03050 |

C. Definitions: None

D. Applicable Standard Details:

- YT 16500-1 Street Lighting Service Detail
- YT 16500-2 Light Pole Detail

1.02 QUALITY ASSURANCE

A. Reference Standards:

ANSI	American National Standard Institute
ASTM	American Society for Testing and Materials
NEMA	National Electrical Manufacturers Association
NECS	National Electrical Safety Code
NFPA	National Fire Protection Association
UL	Underwriters' Laboratories, Inc.
IESNA	Illuminating Engineering Society of North America
IEEE	Institute of Electrical & Electronics Engineers
IPCEA	Insulated Power Cable Engineers Association
OSHA	Occupational Safety & Health Administration
NEC	National Electrical Code

B. Inspections:

1. Upon completion of work, customer/developer shall secure an electrical inspection from an electrical inspection agency acceptable to the authority having jurisdiction and the local electric company.

C. Testing:

1. All electrical conductors, after installation of wiring and apparatus has been completed, shall be tested by this Contractor to insure continuity, proper splicing, freedom from ground (except "made ground" and those required for protection) and insulation resistance in accordance with Underwriters' requirements. This Contractor shall furnish and employ suitable instruments such as ammeters, volt meters, meggers, etc. Preliminary testing with magnetos will be permitted but will not be accepted as a final or conclusive test.
2. Prior to testing or adjusting, this Contractor shall consult with the Municipality to determine the intended function of any equipment, wiring or systems. This Contractor shall then perform such tests and make the necessary adjustments to ensure that the required function is obtained.
3. Equipment and wiring systems not specified as requiring a specific test shall be tested in operation to determine that all design functions are satisfactorily performed.

1.03 SUBMITTALS

- A. Submit (in triplicate ) Certificate of Compliance following electrical inspection.
- B. Voltage drop calculations, prepared by a Professional Engineer licensed in Pennsylvania.
- C. Photometric data for lighting fixtures and point by point maintained footcandle print out that includes maximum maintained footcandles, minimum maintained footcandles, average maintained footcandles, maximum : minimum ratio, average : minimum ratio.
- D. Efficiency and candle power distribution curve for each type lighting fixture.
- E. Catalog cuts and dimensional data for poles and lighting fixtures proposed.
- F. Concrete base design.

1.04 JOB CONDITIONS

A. Codes and Standards:

1. All electrical work shall meet the requirements of National Electric Code of the National Fire Protection Association. In addition, any state, municipal or other authorities laws, rules or regulations applicable to the work shall be followed.
2. Where applicable, all materials and equipment shall bear the label of approval of the Underwriters Laboratory, Inc.
3. Photometric performance of the installed lighting system shall be within guidelines established by The Illuminating Society of North America.
4. Reference to the codes and standards listed herein shall constitute the minimum acceptable requirements. Where drawings and specification requirements exceed those of the codes listed herein, Contractor shall follow the drawings and specifications.

1.05 COORDINATION - DEVELOPMENT STREET LIGHTING

- A. The electric company's street lighting service is only available to the Municipality. The developer shall coordinate street lighting requests with the Municipality and all street lighting shall conform to the Municipality's and electric company's street lighting specifications.

- B. Customer/developer shall provide the electric company with a preliminary plan showing proposed locations of street light standards. The electric company does not design or approve design of street lighting systems.
- C. The electric company returns plan showing the available source(s) for the street light feed(s) and, if not previously provided, this document which lists material requirements.
- D. Customer/developer shall provide street light luminaire(s) which is equipped to operate with the material, as specified herein and as approved the electric company.
- E. Requirements:
  - 1. Street lights shall be spaced at regular intervals as necessary to conform to the performance criteria. Minor adjustments to spacing may be made to accommodate lot lines, driveways, etc.
  - 2. Customer/developer shall provide the electric company with a final plan showing location of facilities (street lights, service equipment, conduit and cable routing, etc.) and size and type of cables and fusing.
  - 3. Prior to excavating, the contractor shall call the PA One Call system.
  - 4. Customer/developer shall install facilities in accordance with requirements of the electric company, the Municipality, the manufacturer, the National Electric Code, and final plan. The customer/developer is required to provide and/or install:
    - a. All trenching and backfilling, including service cable from source to junction box.
    - b. All cable, conduit, foundations, standards, luminaires, lamps, and photoelectric controls as per developer agreement with municipality.
    - c. Service equipment at each source location designated by the electric company to facilitate street lighting cable connections.
  - 5. Customer/developer shall secure an electrical inspection from the electric company accepted electrical inspection agency before the electric company will energize.
  - 6. Upon receipt of a street lighting agreement from the Municipality and the electrical inspection certificate, the electric company will:
    - a. Install service to the line side of the service equipment.
    - b. Install on each streetlight standard and identification tag to show grid location and an additional tag to show the maintenance agreement, lamp type and size.
  - 7. Note that a contract for energy and maintenance of fixtures with the Municipality and the electric company is required prior to the electric company energizing the street lighting system.

## 1.06 CALCULATIONS

- A. Voltage drop shall be calculated to ensure voltage drop will not exceed the requirements of the National Electrical Code.
- B. Point by point footcandle calculations shall be performed to verify that lighting system photometric performance conforms to the IESNA recommendations, as adopted by the Municipality.



PART 2 - PRODUCTS

2.01 LAMPS

A. High pressure sodium meeting the following requirements:

Lamp Watts:	100W	150W	250W
Ballast Code:	S54	S55	S50
Lamp Volts:	55V	55V	100V
Light Center Length:	5"	5"	5"
Burning Position:	Any	Any	Any
Base Type:	Mogul	Mogul	Mogul

2.02 BALLASTS

A. HID Fixture Ballasts: HID fixture ballasts shall conform to the following:

1. High power factor.
2. No inrush current condition.
3. Current during warm-up shall be less than normal operating current.
4. Lamp starting to -20 degrees F for outdoor ballasts.
5. Input line voltage range plus or minus 10 percent, minimum.
6. Fused, fuse located in had hole at bottom of pole.

B. Manufacturer: Advance.

C. Substitutions: General Electric, Universal, or same manufacturer as lighting fixture manufacturer.

2.03 POLES

A. Street Light Pole:

1. All poles shall have a hand hole near base of pole.
2. All anchor bolt nuts shall be covered, either by metal pole base cover furnished with pole or by nut covers furnished by pole manufacturer.
3. Lighting standards shall have each luminaire separately ballasted. Each ballast shall be separately fused with all fuses located near the hand hole of the pole base, where easily accessible.
4. Weep holes shall be provided in the base of the pole shaft to prevent any accumulations of water.
5. The pole shall contain a hand hole sufficiently large to allow inspection of splices, ground connection, and fuses, and ability to repull circuitry between poles. A ground pad shall be welded inside, ground smooth and tapped to receive a 1/4-20 thread, for lugged connection to ground rod.
6. Pole finish shall be polyester powder coat paint, color as approved by Municipality and/or the electric company.
7. Pole shall be 12' high above finish grade, including base; 14 feet high at intersections.
8. Manufacturer: As approved.

## 2.04 FUSE AND FUSE HOLDER

- A. Fuse and fuse holder for the fuse disconnect in the customer's junction box shall be per the electric company's requirements, fuse size as required.

## 2.05 LIGHTING FIXTURES

### A. Collector/Arterial Roads

1. Volts: 120V.
2. Arm mounted, show box (90E cutoff).

### B. Local Roads

1. Volts: 120V.
2. Mounting: Post-top.
3. Type: High pressure sodium.
4. Description: Die-cast aluminum housing, fully enclosed and gasketed. UL listed "suitable for wet locations". Impact and heat resistant glass lens. NEMA Type III distribution.
5. On projects that Met Ed will maintain lighting fixtures after installation, fixtures shall conform to Met Ed's requirements.
6. Manufacturer: As approved (same as pole manufacturer).

## 2.06 STRUCTURAL REQUIREMENTS

- A. All poles, concrete bases, fixtures shall be installed as an integral unit to withstand 100 mph winds, 120 mph gusts.
- B. All pole embedded depths and/or concrete bases shall be shown on the drawings, shall be designed by and the design drawings sealed by a Professional Engineer, licensed in Pennsylvania, taking into account soil conditions at the location of the pole.
- C. All dimensions of the pole, base plate, material type and thickness, and welding information shall appear on the shop drawings along with wind loading for pole and lighting fixtures.

## 2.07 PHOTO ELECTRIC CONTROL

- A. Photo electric controls must be suitable for use with an EEI-NEMA standard twist lock receptacle, shall have a maximum load capability of 1800 volt-amperes, shall be equipped with suitable type surge protection, and have the following characteristics:
  1. Operating Voltage: 120V
  2. Voltage Range: 105-130V
  3. Time Delay: 10 Sec. Max.

## 2.08 CONDUIT

- A. Polyvinyl Chloride (PVC) - Schedule 40.
- B. Extruded from virgin polyvinyl chloride compound.

- C. Resistant to water, oil, outdoor aging, exposure to sunlight, underground environments, and corrosive atmospheres.
- D. Flame retardant for use above ground, resistant to low temperatures, and resistant to distortion due to heat under conditions likely to be encountered in intended service.
- E. Sufficient strength to withstand abuse, such as impact and crushing during handling, installation, and service. Ten foot lengths with one coupling furnished for each length.
- F. Minimum Size: 1 inch.
- G. Each length clearly and durably marked with manufacturer's name. Markings shall be permanent for PVC used above ground.
- H. PVC conduit shall be UL listed.
- I. Comply with applicable ASTM testing procedures and specifications.
- J. Fittings:
  - 1. Conform to applicable PVC conduit specifications above.
  - 2. Manufacturer: Same as PVC conduit manufactures.

## 2.09 WIRE

- A. All wire and cable shall conform to the following:
  - 1. Copper shall not be less than 98 percent conductivity.
  - 2. Single conductor, unless otherwise indicated.
  - 3. Color coded.
  - 4. Marked with classification type, conductor size, and voltage rating, every foot, where applicable.
  - 5. Minimum Size: #12 AWG, unless otherwise specified.
  - 6. Sizes #8 AWG and larger shall be stranded.
  - 7. UL listed.
- B. Wire Specification No. 1
  - 1. Type THW insulation, UL listed.
  - 2. 600 volt insulation.
  - 3. Ampacity based upon maximum conductor temperature of 75 degrees C. in wet or dry locations, continuous operation.
  - 4. Conform to ASTM B3 for solid conductors and ASTM B8 for stranded conductor.
  - 5. Annealed, uncoated copper conductor.
  - 6. Flame retardant, moisture and heat resistant thermoplastic (PVC) insulation.
- C. Wire Specification No. 2
  - 1. Type XHHW insulation, UL listed.
  - 2. 600 volt insulation.
  - 3. Ampacity based upon maximum conductor temperature of 90 degrees C. dry locations and 75 degrees C. wet locations, continuous operation.

4. Moisture and heat resistant cross linked polyethylene (XLP) insulation.
5. Conform to applicable NEMA and IPCEA requirements.
6. Conform to ASTM B3 for solid conductors and ASTM B8 for stranded conductors.
7. Soft copper conductor.

D. Wire Specification No. 4

1. Type THHN/THWN insulation, UL listed.
2. 600 volt insulation.
3. Ampacity based upon maximum conductor temperature of 90 degrees C. dry locations (THHN) and 75 degrees C. dry and wet locations (THWN)), continuous operation.
4. Flame retardant, moisture and heat resistant thermoplastic (PVC) insulation with nylon jacket.
5. Conform to applicable NEMA and IPCEA requirements.
6. Conform to ASTM B3 for solid conductors and ASTM B8 for stranded conductors.
7. Soft copper conductor.

## 2.10 CONNECTORS

A. Connector Specification No. 1 - Splice Connectors

1. For insulated wire, 600 volt and under, #8 AWG and smaller.
2. Compression solderless connector.
3. Insulated or non-insulated.
4. UL listed.
5. Manufacturer: Buchanan B-cap.
6. Substitutions: Ideal Wing-nut, 3M Schotchlok.

B. Connector Specification No. 2 - Splice Connectors

1. For insulated wire, 600 volts and under, #6 AWG and larger.
2. Split bolt pressure connector.
3. Bronze.
4. UL listed.
5. Manufacturer: Anderson.

6. Substitutions: Thomas & Betts, Penn-Union, Dossert, Burndy, Reliable Electric, Ideal.

C. Connector Specification No. 3 - Splice Connectors

1. For insulated wire, 600 volts and under, #6 AWG and larger.
2. Compression or crimp connector, short sleeve.
3. Copper.
4. UL listed.
5. Manufacturer: Anderson.
6. Substitutions: Thomas & Betts, Dossert, Burndy, MAC, 3M, Ideal.

D. Connector Specification No. 4 - Lug connector

1. For insulated wire, 600 volt and under, #8 AWG and larger.

2. Compression or crimp connector, short sleeve.
3. Copper.
4. UL listed.
5. Manufacturer: Anderson.
6. Substitutions: Thomas & Betts, Penn-Union, Dossert, Burndy, MAC, 3M, Ideal.

E. Connector Specification No. 5 - Lug connector

1. For insulated wire, 600 volt and under, #8 AWG and larger.
2. Bolted type pressure connection, hex head or hex socket pressure bolts.
3. Copper.
4. UL listed.
5. Manufacturer: Penn-Union.
6. Substitutions: Thomas & Betts, Anderson, Dossert, Burndy, Ideal.

F. Connector Specification No. 6 - Lug Connector.

1. For insulated wire, 600 volt and under, #10 AWG and smaller.
2. Compression or crimp type.
3. Standard barrel, insulated for 600 volts.
4. Ring terminal or flanged or flared block spade terminal.
5. Copper.
6. UL listed.
7. Manufacturer: Penn-Union Penn Crimp.
8. Substitutions: Ideal Crimp Terminal, Thomas & Betts Sta-Kon, Burndy Insulug, MAC MiniDent, 3M Scotchlok Terminals.

G. Connector Application

1. Unless otherwise noted, connectors shall be used for insulated wire, 600 volts and under as follows:

<b>CONNECTOR SCHEDULE</b>	
Application	Connector Spec. No.
<b>Splice Connectors:</b>	
#8 AWG and smaller	1
#6 AWG and larger	2 or 3
<b>Lug Connectors:</b>	
Stranded wire connection under head of binding screw or bolt	4 or 6
Connection to equipment bus, or screw or bolt terminals	4, 5, 6, or manufacturer supplied lugs

2.11 TAPE

A. Tape Specification No. 1 - Tape for Insulation 600 Volts or Less

1. Vinyl plastic all weather electrical tape.
2. Manufacturer: 3M Scotch 33+.
3. Substitutions: Tomic, Okonite.

B. Tape Specification No. 2 - Underground Marker Tape

1. Material: Red, plastic, 6 inches wide.
2. Marking: CAUTION - BURIED ELECTRIC LINE BELOW, or similar wording.
3. Manufacturer: Griffolyn, Inc.
4. Substitutions: Allen Company.

2.12 WIRE MARKERS

A. Wire Marker Specification No. 2 - Vinyl plastic or Vinyl Polyester.

1. Temperature Range: to 250 degrees F.
2. Self-sticking adhesive backing.
3. Waterproof, solvent proof.
4. Printing permanently protected.
5. Manufacturer: Thomas & Betts E-Z-Code, Type WSL.
6. Substitutions: W.H. Brady Co. Type CAB.

2.13 GROUND RODS

A. Type: High strength steel core.

B. Construction : Copper exterior welded to the steel core.

C. Chamfered top to prevent mushrooming. Pointed end.

D. Minimum Diameter

1. 10 foot rod: 3/4 inch diameter.
2. Above 10 feet: 1 inch diameter.

E. For lengths over 10 feet, sectional rods with steel driving bolt may be furnished.

F. Manufacturer: Copperweld.

G. Substitutions: Penn-Union, Weaver.

2.14 GROUND CONNECTORS

A. Ground Connector Specification No. 2

1. Type: Ground grid clamps. Compression connection to cable or rod.

2. High conductivity cast copper fittings.
3. Cable, rod, plate or combination connector, as required.
4. Suitable for direct burial or imbedded in concrete.
5. Manufacturer: Thomas & Betts.
6. Substitutions: Burndy.

B. Ground Connector Application

1. Unless noted otherwise, ground connectors shall be installed as follows:
  - a. Connection of ground wire or ground grid cable to ground rod, building steel or another ground grid cable.

### PART 3 - EXECUTION

#### 3.01 RACEWAY INSTALLATION

A. PVC conduit shall be installed as follows:

1. Expansion joints shall be installed where expansion and contraction of PVC occurs due to changing temperature conditions.
2. Joints in PVC conduit runs shall be in accordance with manufacturer's recommendations.
3. PVC conduit shall not be used where subject to ambient temperature exceeding those which conduit has been approved.
4. Fittings as specified under Raceway Specification No. 4 shall be used when installing PVC conduit.
5. Install ground wire, sized per NEC in all PVC conduit runs.
6. Underground raceways or duct banks shall have a marker or warning tape installed above raceway, 12 inches below finished grade. Use Tape Specification No. 2. Duct banks with widths over 12 inches shall have 6 inch wide tape runs installed side-by-side on 12 inch (maximum) centers.

#### 3.02 WIRING METHODS

- A. Wiring shall be installed in raceways unless otherwise noted.
- B. Use color coded wire throughout as required by National Electric Code for convenience in testing and maintenance. Neutral conductors shall be color coded neutral gray or white; grounding conductors shall be green.
- C. Pull wire into conduit so that insulation will not be damaged. Approved pulling compound shall be used to assist in pulling of 600 volt wire into conduit. Oil or grease will not be permitted. Pulling compound shall be compatible with wire insulation and conduit.

- D. Conductors shall be installed continuous from outlet to outlet, without splicing except within outlet or junction boxes.
- E. Noninsulated splices in insulated wire, 600 volts and under shall be factory insulated as follows:
  - 1. Rubber and friction tape coated with Scotchkote or similar coating.
  - 2. Scotchfil or equivalent electrical putty with Tape Specification No. 1.
  - 3. Insulation of splices shall provide same insulation qualities as insulation of wire being spliced.
- F. Stranded wire shall not be placed under the head of a binding screw or bolt. Refer to Part 2 - Products, this Section, for connectors to be used in stranded wire connections under head of binding screw or bolt.
- G. Wire shall be identified by use of wire markers at termination points, including outlet boxes, pull boxes, junction boxes, wireways and at locations where wire changes direction within an enclosure. Unless otherwise specified, wire markers shall be as specified under Wire Marker Specification No. 2.

#### 3.04 GROUND ROD INSTALLATION

- A. Ground rods shall be installed as required by National Electric Code near the customer's junction box for the electrical service ground.
- B. Ground rods shall be driven to a depth so that top of rod is 2 feet below grade.

#### 3.04 GROUNDING

- A. Equipment Grounding:
  - 1. Unless otherwise specified, conductive noncurrent carrying electrical materials and equipment shall be grounded. Non-electrical items of equipment shall be grounded as indicated on Drawings. Grounding shall be in accordance with National Electrical Code requirements.
  - 2. Grounding shall be separate insulated grounding conductors pulled with phase conductors. Grounding system shall be electrically, and mechanically continuous from all outlet devices, power utilization equipment, and distribution equipment to system main ground point.
  - 3. Bonds and jumpers shall be furnished and installed where required during construction and where necessary to ensure both operation and safety.
  - 4. Service ground point shall be ground rods near the customer's junction box.
  - 5. Neutral conductors shall be continuous throughout system and shall be grounded only at switchboard neutral.
  - 6. Ground wire shall be installed in all PVC raceway runs. Ground wires shall be insulated.



B. Grounding Tests:

1. Ground resistance of main system grounding point shall be inspected and shall not exceed values required by National Electrical Code. Inspection shall be made using two auxiliary ground rod (three point) method or other approved method. If resistance is found to be higher than that allowed by National Electric Code, additional ground rods shall be driven until a resistance below allowed value is obtained.
2. Outside inspections shall not be performed during unusually wet conditions. Check shall be made during dry weather conditions.
3. Complete inspection record shall be submitted to the Municipality showing resistance values and calculations and shall indicate method of test.

3.05 EXCAVATION

- A. Excavate trenches and for pole bases as specified in Section 02221. Provide 30" minimum cover from the top of the conduit to the finished grade elevation.

3.06 PAVING AND RESTORATION

- A. Paving and restoration shall be as specified in Section 02575.

3.07 CONCRETE

- A. Concrete shall be placed in accordance with specified in Sections 03000 and 03050.

3.08 MAINTENANCE

- A. Developer shall provide an extra pole and light fixture for each type installed for the Municipality and deliver to designated site for storage.
- B. Developer is responsible for repairs and maintenance for 6 months after acceptance of installation (release of security).

END OF SECTION

## INSTALLATION REQUIREMENTS

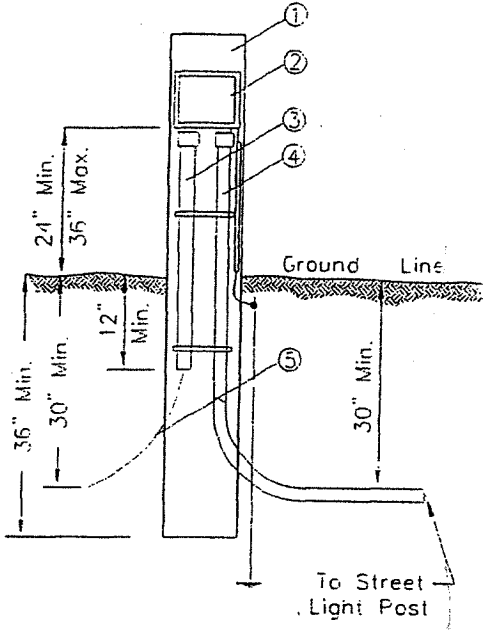

① **SERVICE SUPPORT**

Service support shall be a solid 6 inch by 6 inch pressure treated timber with a minimum setting depth of 36 inches. If service is from underground facilities, the service support must be located a minimum of 24 inches and a maximum of 72 inches from the rear of the transformer foundation, handhole or pedestal. If service is from overhead facilities, the service support must be a minimum of 60 inches or a maximum of 72 inches from the pole.

② **SERVICE DISCONNECT EQUIPMENT**

Provide a manual reset breaker or fused disconnect with associated grounding installed in accordance with the requirements of the National Electrical Code (NEC) and any local terminal lugs must accept #12 AWG solid through #4 AWG stranded or disconnect equipment rated greater than 30 amps. Enclosure must prevent access by unauthorized persons and shall be a NEMA Type 3R.

③ **SERVICE LATERAL CONDUIT, CONNECTORS AND CLAMPS**

The minimum size service lateral conduit is 3/4 inch schedule 40 PVC on 30 amp disconnect equipment and 1 inch schedule 40 PVC on disconnect equipment rated greater than 30 amps. This conduit must extend from the service disconnect to 12 inches below ground line.

④ **DISTRIBUTION CONDUIT, CABLE, CONNECTORS AND CLAMPS**

This equipment must meet the requirements of the NEC and any local municipal codes.

⑤ **Service Lateral Conductors (Provided by electric company)**

NOTE: NOT TO SCALE

## YORK TOWNSHIP CONSTRUCTION & MATERIALS SPECIFICATIONS

**YORK TOWNSHIP BOARD OF COMMISSIONERS**  
 190 OAK ROAD  
 DALLASTOWN, PENNSYLVANIA 17313  
 TELEPHONE: 717-741-3861 FAX: 717-741-5009

### STREET LIGHTING SERVICE DETAIL

DATE:	1/24/2005
DRAWN BY:	ARE
CHK BY:	SKS
NO	YT 1E500-1

K:\091920003\dwg\YT1E500-1.dwg, 1/27/2005 10:13:36 AM

SHOEBOX  
FIXTURE  
(90° CUTOFF)\*

METAL POLE, PAINT COLOR  
SELECTED BY TOWNSHIP

12' HIGH (14' AT INTERSECTIONS)

FINISH GRADE

COVERED ANCHOR BOLTS

CONCRETE FOUNDATION

\* REQUIRED STYLE ON COLLECTOR/ARTERIAL  
AND MAJOR THOROUGHFARES. OTHER STYLES  
MAY BE USED ON LOCAL ROADS AS APPROVED  
BY TOWNSHIP.

NOTE: NOT TO SCALE

## YORK TOWNSHIP CONSTRUCTION & MATERIALS SPECIFICATIONS

YORK TOWNSHIP BOARD OF COMMISSIONERS  
190 OAK ROAD  
DALLASTOWN, PENNSYLVANIA 17313  
TELEPHONE: 717-741-3861 FAX: 717-741-5009

### LIGHT POLE DETAIL

DATE:	1/24/2005
DRAWN BY:	ARE
CHK. BY:	SKS
NO:	YT 16500-2

C:\991920003\dwg\116500-2.dwg, 1/24/2005 10:11:10 AM